

For Equivalent Engineering Drawing See 40832301-Q2 H

Figure 5-11. Display Assembly

COMPONENT LIST FOR THE DISPLAY ASSEMBLY (40832301-H)

C1	Capacitor-Tantalum	22 Mf	70025104
C2	Capacitor-Monolithic Ceramic	.1 Mf	70028511
C3	Capacitor-Monolithic Ceramic	.001 Mf	70028518
C4	Capacitor-Monolithic Ceramic	.1 Mf	70028511
C5	Capacitor-Monolithic Ceramic	.1 Mf	70028511
C6	Capacitor-Monolithic Ceramic	100 Pf	70028601
C7	Capacitor-Monolithic Ceramic	100 Pf	70028601
C8	Capacitor-Monolithic Ceramic	.1 Mf	70028511
C9	Capacitor-Electrolytic	10 Mf	70023808
C13	Capacitor-Tantalum	22 Mf	70025104
C14	Capacitor-Tantalum	22 Mf	70025104
C15	Capacitor-Electrolytic	1 Mf	70028029
C16	Capacitor-Monolithic Ceramic	.001 Mf	70028518
C17	Capacitor-Monolithic Ceramic	.001 Mf	70028518
C18	NOT USED		
C19	Capacitor-Monolithic Ceramic	.001 Mf	70028518
D1	Diode-Zener	10 V	70035514
D2	Diode-Zener (15V)		70035522
D3-D10	Diode-Silicon		70035005
D11	NOT USED		
D12	LED-Block (90)		70035201
D13-D16	Diode-Silicon		70035005
D17	Diode-Silicon		70035012
D18	Diode-Silicon		70035012
D19	Diode - Zener (5.1 V)		70035526
DS1	Display-VAC FLU (16 Character)		30933201
E1	Transformer, DC-DC/AC		30942101
J1	Wafer-Polarizing 90 (5 CKT)		70074405
J2	Wafer-Polarizing 90 (9 CKT)		70074409
J3	Wafer-Polarizing 90 (12 CKT)		70074412
J4	Wafer-Polarizing 90 (8 CKT)		70074408
J5	Wafer-Polarizing 90 (6 CKT)		70074406

Q1	Transistor-Silicon (PNP)	70030104
Q2	Transistor-Silicon (NPN)	70030008
Q3	Transistor-Silicon (NPN)	70030008
Q4	Transistor-Silicon (PNP)	70030104
Q5	Transistor-Darlington (NPN)	70030213
Q6	Transistor-Darlington (NPN)	70030213

Note: All resistors are ¼ watt 5%, unless otherwise noted.

R1	Resistor-Carbon	1.8 K	79901182
R2	Resistor-Carbon	33 K	79901333
R3	Resistor-Carbon	4.7 K	79901472
R4	Resistor-Carbon	4.7 K	79901472
R5	Resistor-Carbon	10 K	79901103
R6	Resistor-Carbon	10 K	79901103
R7	Resistor-Carbon	100 K (1/8 W)	79905104
R8	Resistor-Carbon	1 K	79901102
R9	Resistor-Carbon	4.7 K	79901472
R10	Resistor-Carbon	10 K	79901103
R12	Resistor-Carbon	4.7 K	79901472
R13 Thru R44	Resistor-Carbon	100 K (1/8 W)	79905104
R45	Resistor-Carbon	10 K	79901103
R46	Resistor-Carbon	10 K	79901103
R47	Resistor-Carbon	100 K (1/8 W)	79905104
R48	Resistor-Carbon	100 K (1/8 W)	79905104
R49	Resistor-Carbon	56 K	79901563
R50	Resistor - Carbon	39 Ohm	79901390
R51	Resistor - Carbon	39 Ohm	79901390

U1	Driver-Display (VAC FLU) (10937)	30800237
U2	Receiver-Dual (RS-422)	30800228
U3	Driver-Motor (Full Bridge) (UDN-2953B)	30800229 ¹
U4	Driver-Motor (Full Bridge) (PBL-3717)	30800241 ¹

VR1	Regulator-Voltage (Linear IC)	70036506
-----	-------------------------------	----------

¹ Use either 30800229 in the U3 position, or use 30800241 in the U4 position.

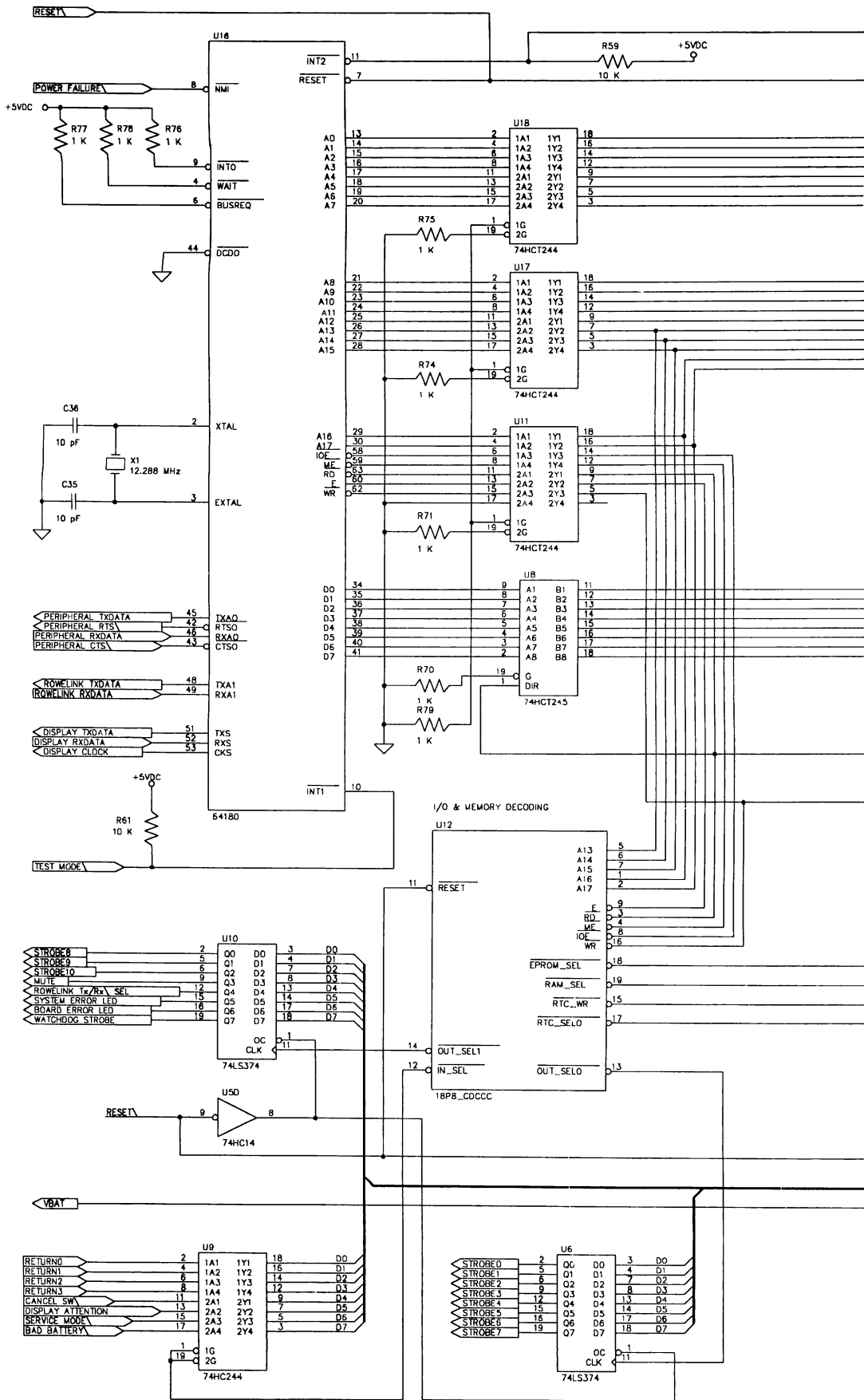

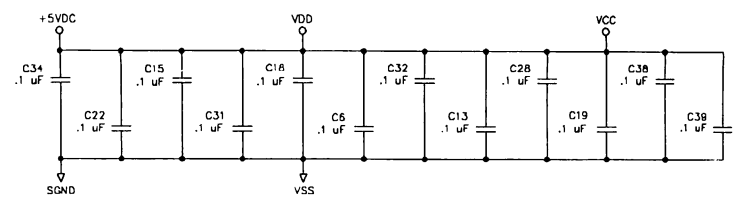
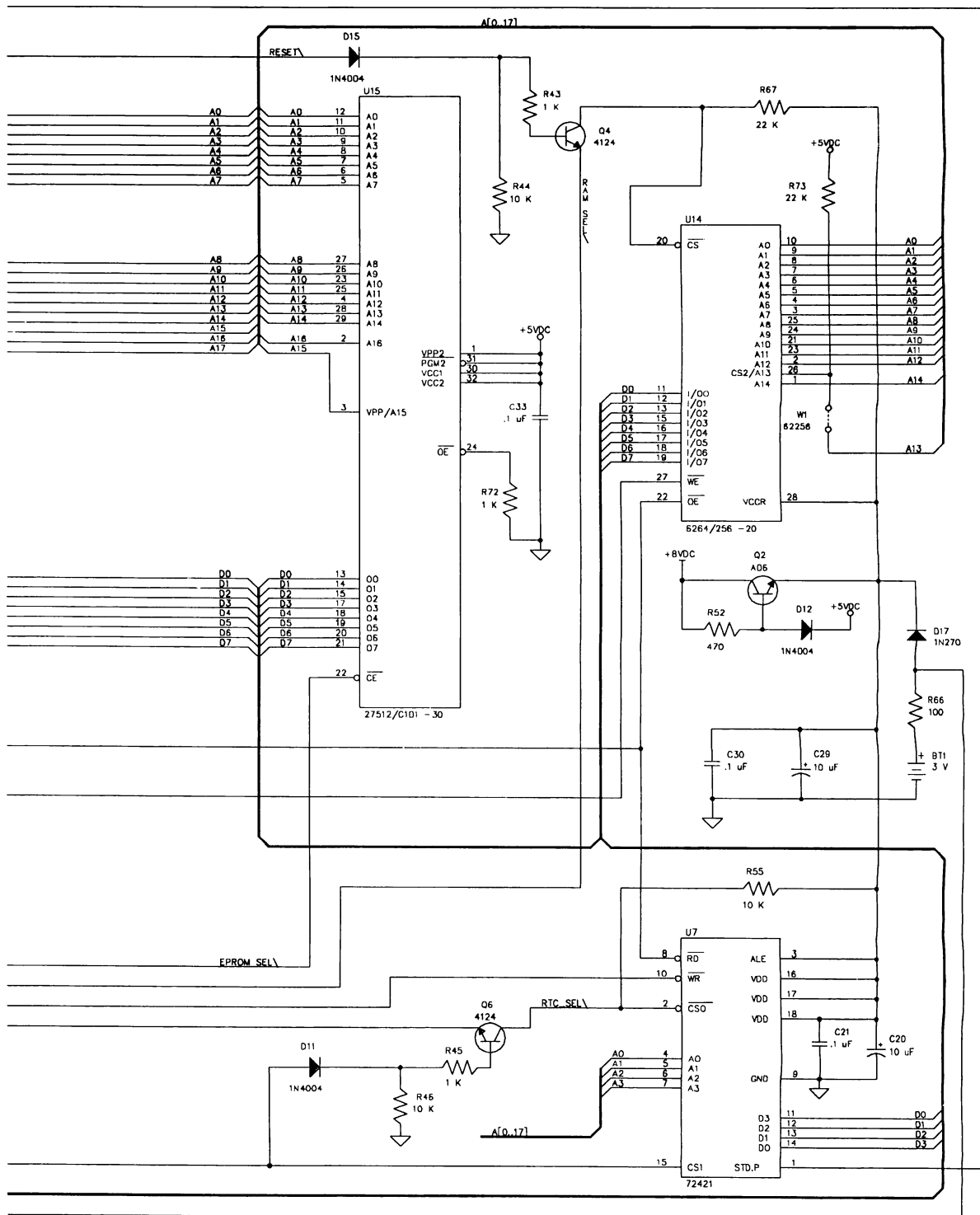

For Equivalent Engineering Drawing See 61031101-Q2 D

Figure 5-12A. Central Control Computer Schematic, Sheet 1

DISPLAY/KEYBOARD INTERFACE

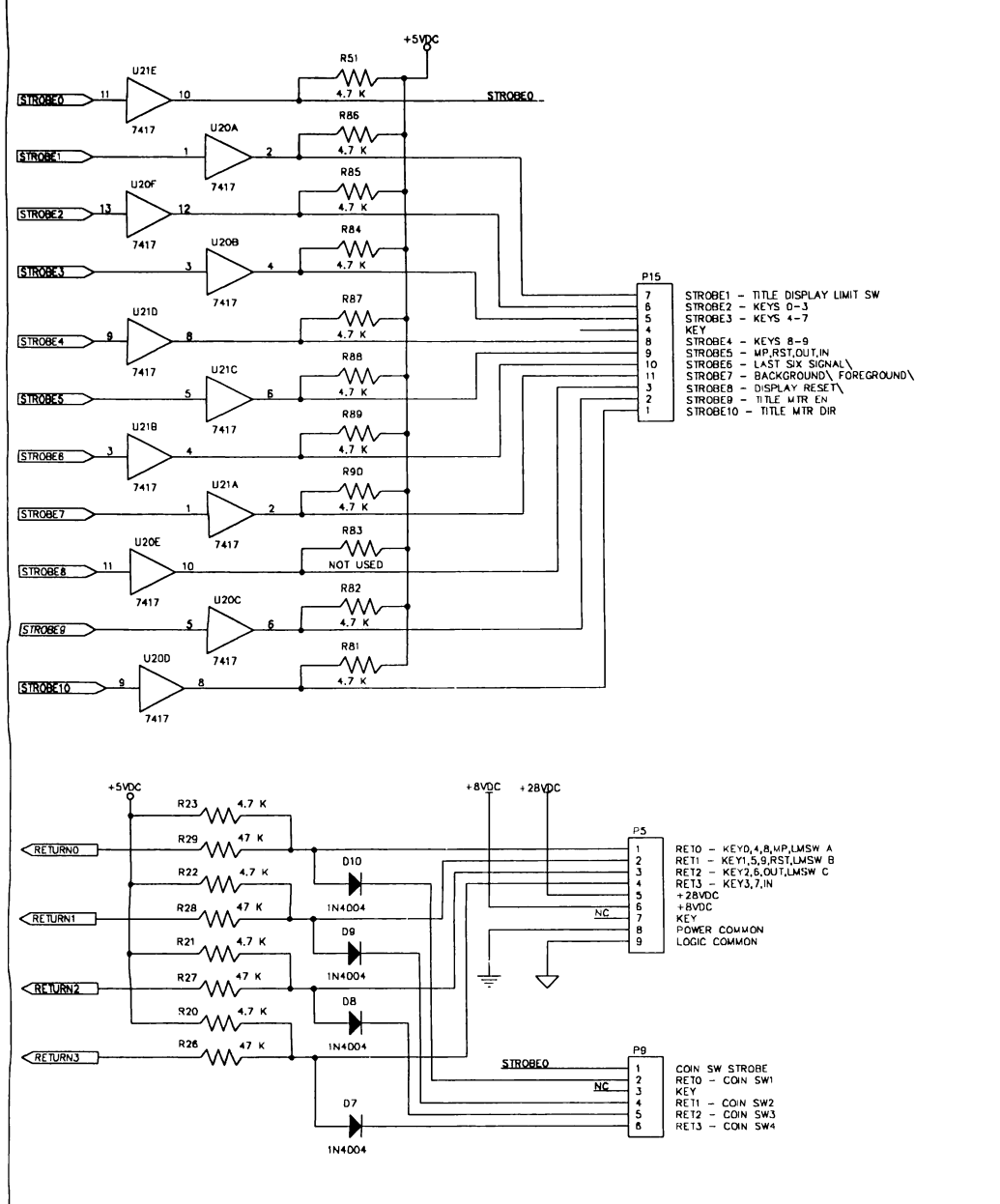

DISPLAY INTERFACE (85422)

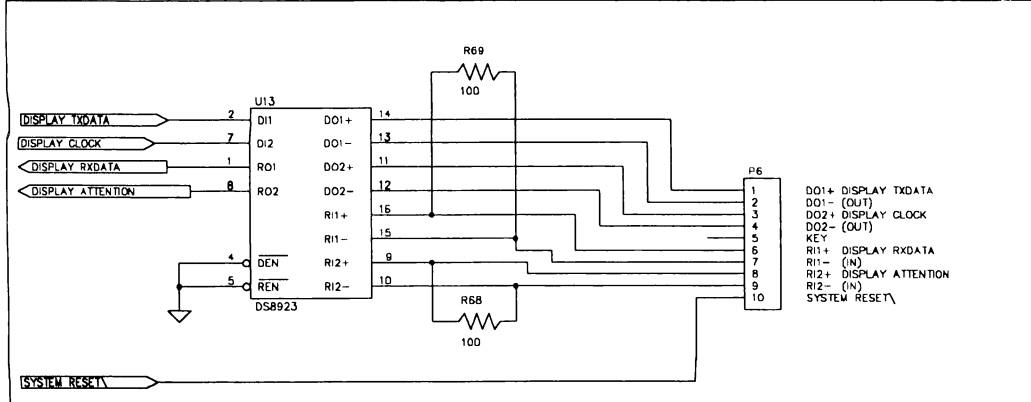

CD-100 C.C.C. IC POWER AND COMMON PIN CHART					
REF.	GENERIC PART #	POWER		COMMON	
		+5VDC	+8VDC	LOGIC	POWER
U1	MAX232	16	-	15	-
U2	LM339	-	3	12	-
U3	2003	-	-	8	-
U4	LM555	8	-	1	-
U5	74HC14	14	-	7	-
U6	74LS374	20	-	10	-
U7	72421	16,17,18	-	9	-
U8	74HCT245	20	-	10	-
U9	74HC244	20	-	10	-
U10	74LS374	20	-	10	-
U11	74HCT244	20	-	10	-
U12	18P8_CDCCC	20	-	10	-
U13	DS8923	3	-	6	-
U14	6264/6256	28	-	14	-
U15	27512/27C101	32,30	-	16	-
U16	64180	32	-	1,33	-
U17	74HCT244	20	-	10	-
U18	74HCT244	20	-	10	-
U19	75176	8	-	5	-
U20	7417	14	-	7	-
U21	7417	14	-	7	-

For Equivalent Engineering Drawing See 61031101-Q2 D

Figure 5-12A. Central Control Computer Schematic, Sheet 4

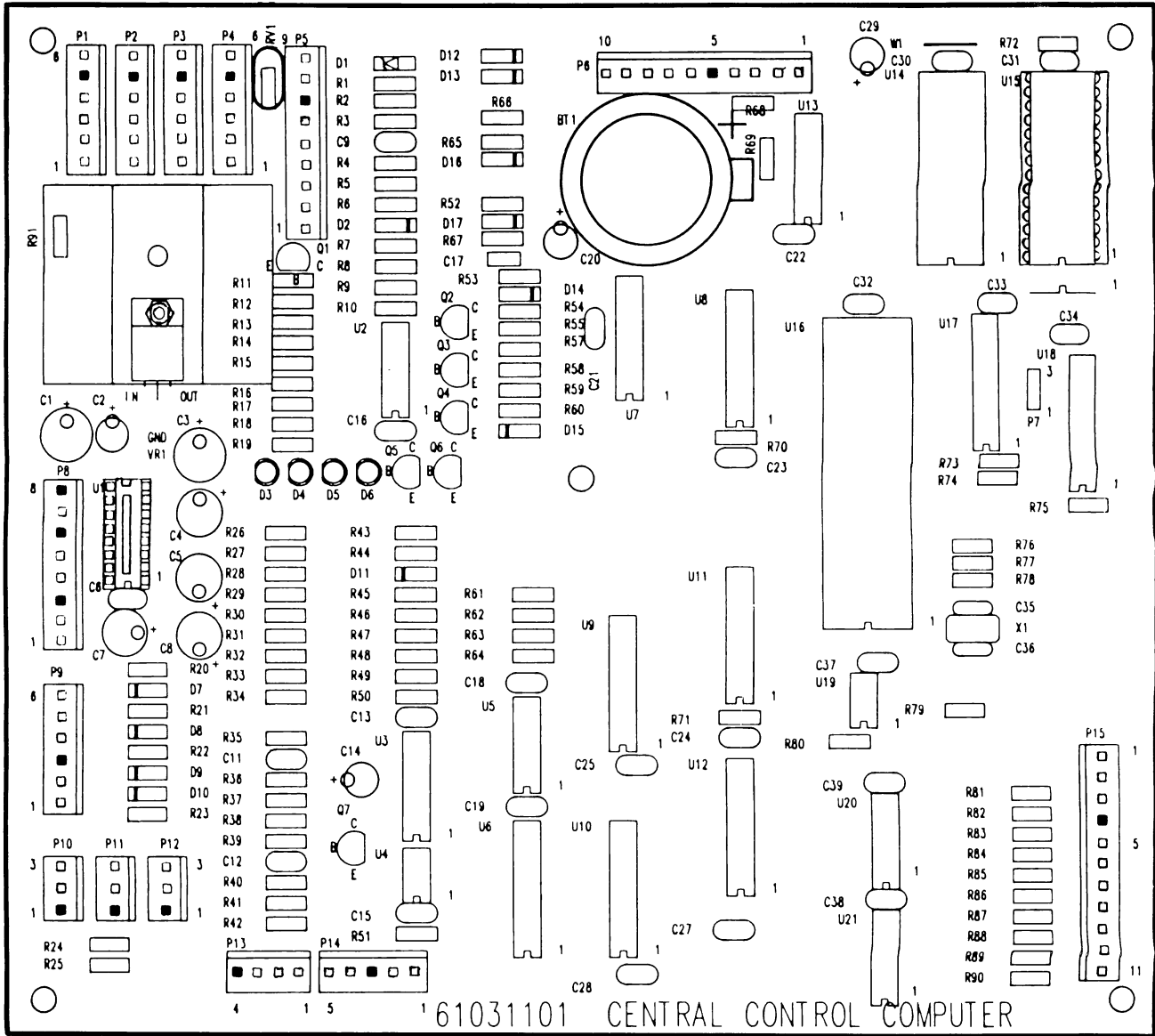

Figure 5-12B. Central Control Computer Circuit Board Layout

COMPONENT LIST FOR CENTRAL CONTROL COMPUTER (61031101-J)

BT1	Battery - Lithium	750 mah 3V OR 160 mah 3V	40788901 30873101
C1	Capacitor - Electrolytic	100 mf	70023814
C2	Capacitor - Tantalum	1 mf	70025121
C3	Capacitor - Electrolytic	100 mf	70023814
C4	Capacitor - Electrolytic	10 mf	70023808
C5	Capacitor - Electrolytic	10 mf	70023808
C6	Capacitor - Monolithic Ceramic	.1 mf	70028511
C7	Capacitor - Electrolytic	10 mf	70023808
C8	Capacitor - Electrolytic	10 mf	70023808
C9	Capacitor - Monolithic Ceramic	.1 mf	70028511
C10	NOT USED		
C11	Capacitor - Monolithic Ceramic	.1 mf	70028511
C12	Capacitor - Monolithic Ceramic	.1 mf	70028511
C13	Capacitor - Monolithic Ceramic	.1 mf	70028511
C14	Capacitor - Electrolytic	10 mf	70023808
C15	Capacitor - Monolithic Ceramic	.1 mf	70028511
C16	Capacitor - Monolithic Ceramic	.1 mf	70028511
C17	Capacitor - Monolithic Ceramic	.01 mf	70028502
C18	Capacitor - Monolithic Ceramic	.1 mf	70028511
C19	Capacitor - Monolithic Ceramic	.1 mf	70028511
C20	Capacitor - Electrolytic	10 mf	70023808
C21	Capacitor - Monolithic Ceramic	.1 mf	70028511
C22	Capacitor - Monolithic Ceramic	.1 mf	70028511
C23	Capacitor - Monolithic Ceramic	.1 mf	70028511
C24	Capacitor - Monolithic Ceramic	.1 mf	70028511
C25	Capacitor - Monolithic Ceramic	.1 mf	70028511
C27	Capacitor - Monolithic Ceramic	.1 mf	70028511
C28	Capacitor - Monolithic Ceramic	.1 mf	70028511
C29	Capacitor - Electrolytic	10 mf	70023808
C30	Capacitor - Monolithic Ceramic	.1 mf	70028511
C31	Capacitor - Monolithic Ceramic	.1 mf	70028511
C32	Capacitor - Monolithic Ceramic	.1 mf	70028511
C33	Capacitor - Monolithic Ceramic	.1 mf	70028511
C34	Capacitor - Monolithic Ceramic	.1 mf	70028511
C35	Capacitor - Monolithic Ceramic	10 pf	70028701
C36	Capacitor - Monolithic Ceramic	10 pf	70028701
C37	Capacitor - Monolithic Ceramic	.1 mf	70028511
C38	Capacitor - Monolithic Ceramic	.1 mf	70028511
C39	Capacitor - Monolithic Ceramic	.1 mf	70028511
D1	Diode - Zener (5.1 V)		70035526
D2	Diode - Silicon	IN4004	70035005
D3	Diode - Light Emitting		70035305
D4	Diode - Light Emitting		70035305
D5	Diode - Light Emitting		70035305
D6	Diode - Light Emitting		70035305
D7	Diode - Silicon	IN4004	70035005
D8	Diode - Silicon	IN4004	70035005
D9	Diode - Silicon	IN4004	70035005
D10	Diode - Silicon	IN4004	70035005
D11	Diode - Silicon	IN4004	70035005
D12	Diode - Silicon	IN4004	70035005
D13	Diode - Silicon	IN4004	70035005
D14	Diode - Silicon	IN4004	70035005
D15	Diode - Silicon	IN4004	70035005
D16	Diode - Silicon	IN4004	70035005
D17	Diode - Germanium	IN270	70035101

P1	Wafer - Polarizing	6 CKT	70075006
P2	Wafer - Polarizing	6 CKT	70075006
P3	Wafer - Polarizing	6 CKT	70075006
P4	Wafer - Polarizing	6 CKT	70075006
P5	Wafer - Polarizing	9 CKT	70075009
P6	Wafer - Polarizing	10 CKT	70075010
P7	NOT USED		
P8	Wafer - Polarizing	8 CKT	70075008
P9	Wafer - Polarizing	6 CKT	70075006
P10	Wafer - Polarizing	3 CKT	70075003
P11	Wafer - Polarizing	3 CKT	70075003
P12	Wafer - Polarizing	3 CKT	70075003
P13	Wafer - Polarizing	4 CKT	70075004
P14	Wafer - Polarizing	5 CKT	70075005
P15	Wafer - Polarizing	11 CKT	70075011

Q1	Transistor - Silicon (PNP)		70030104
Q2	Transistor - Silicon (NPN)		70030008
Q3	Transistor - Silicon (NPN)		70030008
Q4	Transistor - Silicon (NPN)		70031301
Q5	Transistor - Silicon (NPN)		70030008
Q6	Transistor - Silicon (NPN)		70031301
Q7	Transistor - Silicon (NPN)		70030008

Note: All resistors are ¼ watt 5%, unless otherwise noted.

R1	Resistor - Carbon	150 Ohm	79901151
R2	Resistor - Carbon	100 Ohm	79901101
R3	Resistor - Carbon	5.6 K (¼ W, 2%)	79902562
R4	Resistor - Carbon	100 K	79901104
R5	Resistor - Carbon	100 K	79901104
R6	Resistor - Carbon	22 K	79901223
R7	Resistor - Carbon	10 K	79901103
R8	Resistor - Carbon Film	10 K (¼ W, 2%)	79902103
R9	Resistor - Carbon	220 K	79901224
R10	Resistor - Carbon	470 K	79901474
R11	Resistor - Carbon Film	10 K (¼ W, 2%)	79902103
R12	Resistor - Carbon Film	10 K (¼ W, 2%)	79902103
R13	Resistor - Carbon	10 K	79901103
R14	Resistor - Carbon	470 K	79901474
R15	Resistor - Carbon	10 K	79901103
R16	Resistor - Carbon	10 K	79901103
R17	Resistor - Carbon	470 K	79901474
R18	Resistor - Carbon	4.7 K	79901472
R19	Resistor - Carbon	330 Ohm	79901331
R20	Resistor - Carbon	4.7 K	79901472
R21	Resistor - Carbon	4.7 K	79901472
R22	Resistor - Carbon	4.7 K	79901472
R23	Resistor - Carbon	4.7 K	79901472
R24	Resistor - Carbon	10 K	79901103

COMPONENT LIST FOR CENTRAL CONTROL COMPUTER (61031101)

(Continued)

R25	Resistor - Carbon	10 K	79901103
R26	Resistor - Carbon	47 K	79901473
R27	Resistor - Carbon	47 K	79901473
R28	Resistor - Carbon	47 K	79901473
R29	Resistor - Carbon	47 K	79901473
R30	Resistor - Carbon	47 K	79901473
R31	Resistor - Carbon	47 K	79901473
R32	Resistor - Carbon	47 K	79901473
R33	Resistor - Carbon	1 K	79901102
R34	Resistor - Carbon	1 K	79901102
R35	Resistor - Carbon	47 K	79901473
R36	Resistor - Carbon	10 K	79901103
R37	Resistor - Carbon	470 K	79901474
R38	Resistor - Carbon	10 K	79901103
R39	Resistor - Carbon	10 K	79901103
R40	Resistor - Carbon	10 K	79901103
R41	Resistor - Carbon	1 K	79901102
R42	Resistor - Carbon	47 K	79901473
R43	Resistor - Carbon	1 K	79901102
R44	Resistor - Carbon	10 K	79901103
R45	Resistor - Carbon	1 K	79901102
R46	Resistor - Carbon	10 K	79901103
R47	Resistor - Carbon	470 Ohm	79901471
R48	Resistor - Carbon	470 Ohm	79901471
R49	Resistor - Carbon	10 K	79901103
R50	Resistor - Carbon	470 Ohm	79901471
R51	Resistor - Carbon	4.7 K	79901472
R52	Resistor - Carbon	470 Ohm	79901471
R53	Resistor - Carbon	100 Ohm	79901101
R54	Resistor - Carbon	10 K	79901103
R55	Resistor - Carbon	10 K	79901103
R57	Resistor - Carbon	10 Ohm	79901100
R58	Resistor - Carbon	10 K	79901103
R59	Resistor - Carbon	10 K	79901103
R60	Resistor - Carbon	10 Ohm	79901100
R61	Resistor - Carbon	10 K	79901103
R62	Resistor - Carbon	10 K	79901103
R63	Resistor - Carbon	10 K	79901103
R64	Resistor - Carbon	10 K	79901103
R65	Resistor - Carbon	100 Ohm	79901101
R66	Resistor - Carbon	100 Ohm	79901101
R67	Resistor - Carbon	22 K	79901223
R68	Resistor - Carbon	100 Ohm	79901101
R69	Resistor - Carbon	100 Ohm	79901101
R70	Resistor - Carbon	1 K	79901102
R71	Resistor - Carbon	1 K	79901102
R72	Resistor - Carbon	1 K	79901102
R73	Resistor - Carbon	22 K	79901223
R74	Resistor - Carbon	1 K	79901102
R75	Resistor - Carbon	1 K	79901102
R76	Resistor - Carbon	1 K	79901102

R77	Resistor - Carbon	1 K	79901102
R78	Resistor - Carbon	1 K	79901102
R79	Resistor - Carbon	1 K	79901102
R80	Resistor - Carbon	10 K	79901103
R81	Resistor - Carbon	4.7 K	79901472
R82	Resistor - Carbon	4.7 K	79901472
R83	NOT USED		
R84	Resistor - Carbon	4.7 K	79901472
R85	Resistor - Carbon	4.7 K	79901472
R86	Resistor - Carbon	4.7 K	79901472
R87	Resistor - Carbon	4.7 K	79901472
R88	Resistor - Carbon	4.7 K	79901472
R89	Resistor - Carbon	4.7 K	79901472
R90	Resistor - Carbon	4.7 K	79901472
R91	Resistor - Carbon	1 K	79901102
RV1	Metal Oxide Varistor	11 V (OR 14V)	OR 70037505 70037507
U1	NOT USED		
U2	I.C. - Quad Comparator (LM339)	(3302)	70036801
U3	I.C. - Darlington Array	(2003)	70036901
U4	I.C. - Timer	(LM555)	70033801
U5	I.C. - HCT (Hex Schmitt Trigger)	74HC14	79940014
U6	I.C. - Octal Edge Triggered F/F	74LS374	70037111
U7	I.C. - Calendar Clock	72421	30800236
U8	I.C. - HCT (Octal Bus Transceiver)	74HCT245	79930245
U9	I.C. - HC-Tristate Octal Buffer	74HC244	79940244
U10	I.C. - Octal Edge Triggered F/F	74LS374	70037111
U11	I.C. - HCT (Octal Buffer/Line Driver)	74HCT244	79930244
U12	I.C. - PAL 18P8-CDCCC		30800232
U13	I.C. - RS-422 Dual Driver/Rcvr	DS8923	30800230
U14	I.C. - CMOS RAM 8K X 8	6264	70036604
U15	I.C. - 64K X 8 EPROM	27512	70039903
U16	I.C. - Microprocessor	64180	70039126
U17	I.C. - HCT (Octal Buffer/Line DRIVER)	74HCT244	79930244
U18	I.C. - HCT (octal Buffer/Line Driver)	74HCT244	79930244
U19	I.C. - Transceiver (RS-485)	75176	70037801
U20	I.C. - TTL Buffer (Open Collector)	7417	70036305
U21	I.C. - TTL Buffer (Open Collector)	7417	70036305
VR1	Regulator - Voltage (Linear I.C.)	LM340-5	70036505
W1	Not Used		
X1	Crystal - Quartz (12.288 Mhz)		25167314

The chart below shows the various combinations of strobes (outputs from the CCC) and returns (inputs to the CCC) and their corresponding functions.

Strobes 0 through 5 appear on Returns 0 through 3 when the indicated switches are activated.

For Example: If you need to be sure that Key 5 is working, find Key 5 in table 5-3. This matrix entry indicates that, when Strobe 3 is active and Key 5 is pressed, Return 1 becomes active.

Not all of the strobes and returns operate in this matrix mode; Returns 4 through 7 and Strobes 7 through 15 have unique functions, which are listed in the table.

Table 5-3. CD-100 CCC I/O Matrix

		INPUTS							
		RETURNS				DEDICATED			
		0	1	2	3	4	5	6	7
STROBES	0	5¢ Coin Switch	10¢ Coin Switch	25¢ Coin Switch	50¢ Coin Switch	CANCEL SWITCH	DISPLAY ATTENTION	SERVICE SWITCH	LOW BATTERY DET
	1	Title Disp Limit	Title Disp Index	Reserved	UK Defaults				
	2	Key 0	Key 1	Key 2	Key 3				
	3	Key 4	Key 5	Key 6	Key 7				
	4	Key 8	Key 9		Audit Report Start Button				
	5	POPULAR	RESET	OUT	IN				
DEDICATED	6	Not Used							
	7	Background Music Active							
	8	Display Reset - Controls hardware reset on the display driver chip							
	9	Sends speed info to motor chip							
	10	Sends direction info to motor chip							
	11	Mute							
	12	ROWELINK Tx/Rx Select							
	13	SYSTEM ERROR LED							
	14	BOARD ERROR LED							
	15	Watchdog Strobe							