

LAMPEGGIATORE ELETTRONICO ELECTRONIC FLASHER

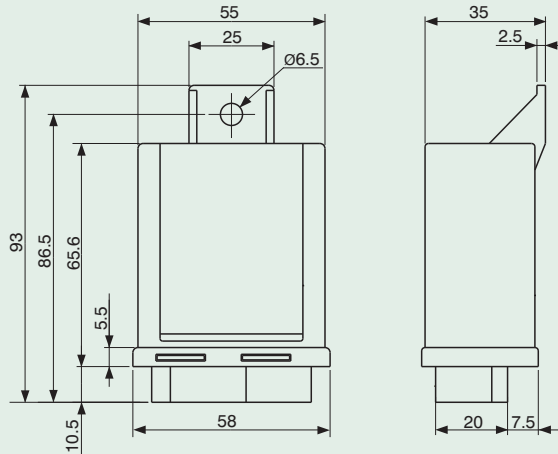

- Materiale corpo: nylon
- Tensione di lavoro: 12V o 24V ± 30%
- Lampade indicatori di direzione: 21W
- Lampade lampeggio emergenza: 21W
- Lampade spia ai contatti: max 5W
- Carichi ausiliari al contatto: max 4W

- Material housing: nylon
- Operating voltage: 12V or 24V ± 30%
- Turn indicator lamps: 21W
- Emergency flashing lamps: 21W
- Warning light on terminals: max 5W
- Contact auxiliary loads: max 4W



PN IMEAR
OC02106000

12V

SCHEMA ELETTRICO - WIRING DIAGRAM

PN IMEAR
OC04927000

24V

