

## Laser Diode



L780P010



### Description

Thorlabs Ø5.6 mm, TO-18 can package discrete laser diode is a compact light source suited to many application. Our lasers are fully compatible with our entire line of Laser Diode and TEC Controllers as well as our selection of Laser Diode Mounts and Collimation Solutions.

### Specifications

Specification	Symbol	Max
Optical Output Power, mW	$P_o$	12
LD Reverse Voltage, V	$V_{R(LD)}$	2
PD Reverse Voltage, V	$V_{R(PD)}$	30
Operation Case Temperature, °C	$T_{op}$	-10 to 60
Storage Temperature, °C	$T_{STG}$	-40 to 85

( $P_o = 10$  mW,  $T_c = 25$  °C)

Specification	Symbol	Min	Typ	Max
Threshold Current, mA	$I_{th}$		14	20
Operation Current, mA	$I_{op}$		24	40
Operating Voltage, V	$V_{op}$		1.8	2.5
Lasing Wavelength, nm	$\lambda_p$	770	780	790
Beam Divergence	$\theta_{//}$	6°	8°	12°
Beam Divergence	$\theta_{\perp}$	25°	30°	32°
Slope Efficiency, mW/mA	$\eta$	0.5	0.65	0.9
Monitor Current, mA	$I_m$	0.3	0.7	1.5
Astigmatism, $\mu$ m	$A_s$		10	15

### Drawings



Top View

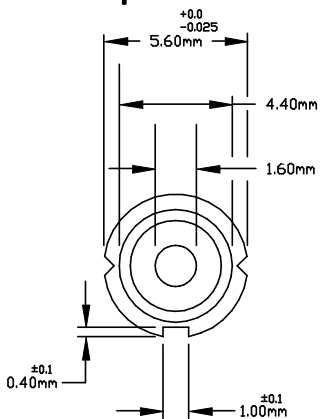

Side View

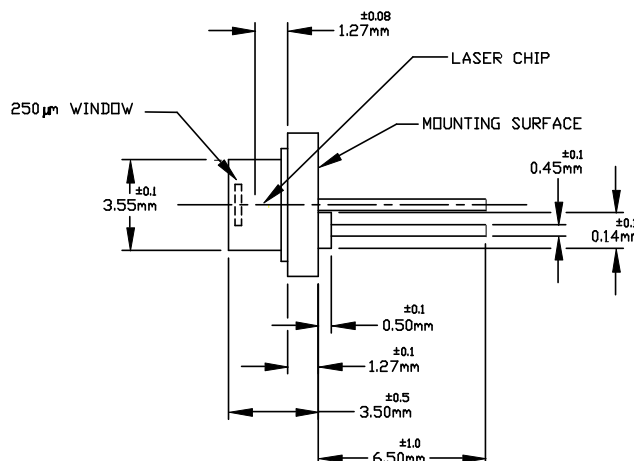

Bottom View

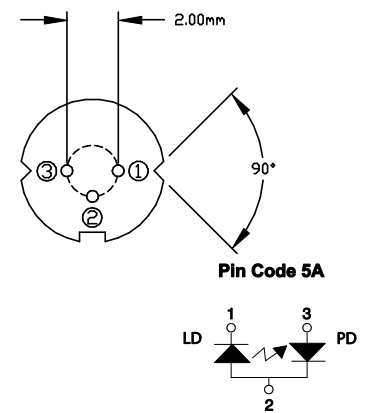

Pin Code 5A

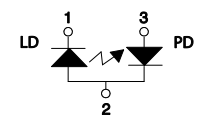

Pin Description

- 1 Laser Cathode
- 2 Case Common
- 3 Monitor Diode Anode

USA, Canada, & S. America  
Thorlabs, Inc.  
435 Route 206  
Newton, NJ 07860, USA  
Tel: 973-579-7227  
Fax: 973-300-3600  
www.thorlabs.com  
email: feedback@thorlabs.com

Europe  
Thorlabs GmbH  
Hans-Böckler-Str. 6  
85221 Dachau, Germany  
Tel: +49-(0)8131-5956-0  
Fax: +49-(0)8131-5956-99  
www.thorlabs.com  
email: Europe@thorlabs.com

UK and Ireland  
Thorlabs LTD.  
1 Saint Thomas Place, Ely  
Cambridgeshire CB7 4EX, GB  
Tel: +44 (0)1353-654440  
Fax: +44 (0)1353-654444  
www.thorlabs.com  
email: sales.uk@thorlabs.com

Scandinavia  
Thorlabs Sweden AB  
Box 141 94  
400 20 Göteborg, Sweden  
Tel: +46-31-733-30-00  
Fax: +46-31-703-40-45  
www.thorlabs.com  
email: scandinavia@thorlabs.com

Japan and Asia  
Thorlabs Japan Inc.  
5-17-1, Ohtsuka  
Bunkyo-ku, Tokyo 112-0012, Japan  
Tel: +81-3-5977-8401  
Fax: +81-3-5977-8402  
www.thorlabs.jp  
email: sales@thorlabs.jp

