

QCX601

+3.3V ~ +5.0V Low Power Ringing SLIC

1. Features

- Single supply voltage: +3.3V to +5.0V.
- Integral high efficiency DC/DC converter.
- Transformerless 2-wire to 4-wire conversion
- Integral ringing generator
- Constant current feed
- Tip/Ring Polarity reversal
- On-hook transmission
- Off-hook detection
- Easy to use, with a minimum number of external components.
- Simplified protection in “on-premise” applications.

2. Applications

- Voice Over Internet Protocol (VoIP)
- Cable Modems
- Key Telephone System
- IP Gateway system
- Wireless Desktop Phone
- Set-top Box System
- Voice Over DSL (VoDSL)
- Short Loop Access Platforms
- Remote Subscriber Units
- Other Terminal Adapters

3. Product Selector

Part Number	Supply Voltage (V)	Loop Current (mA)	Supply Current (off-hook)	Supply Current (ringing)	Ringing Voltage (Vp-p)	Supply Current (on-hook @48V)	Supply Current (on-hook @24V)
QCX601-A	3.1~5.5	24~31	280~330mA	280~320mA	125~145	60~90mA	30~45mA
QCX601-B	3.3~5.5	20~25	220~260mA	210~260mA	115~140	60~90mA	30~45mA
QCX601-C	4.0~5.5	18~23	170~180mA	160~170mA	110~135	30~40mA	20~25mA

Table 1: Ordering Information

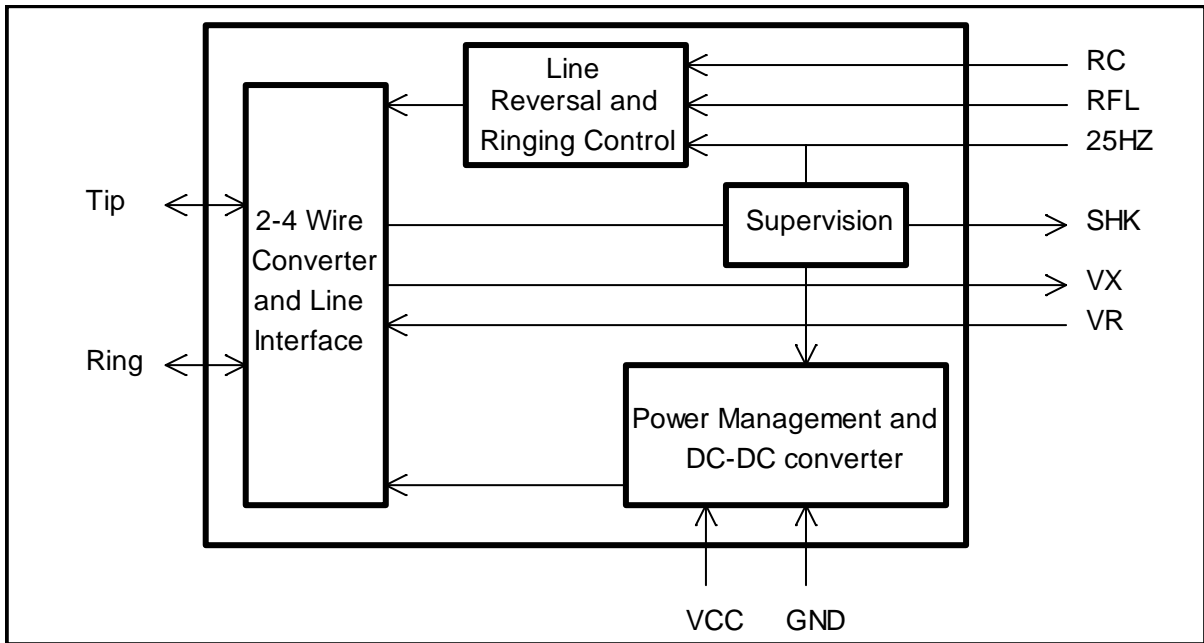

Figure : Functional Block Diagram

4. Pin Description

Pin #	Name	Description
J1-1	RFL	Reverse Input.
J1-2	25HZ	25HZ Input.
J1-3	RC	Ring Mode. Sets bias conditions during ringing. Must be set to logic (H) during ringing. Logic (L) for other modes.
J1-4	SHK	Switch Hook. Indicates an off-hook condition when at logic (H).
J1-5	NC	No Connection.
J1-6	GND	DC/DC Ground. Ground input for the DC/DC converter.
J1-7	VCC	DC/DC Supply. +3.3V ~ +5V input for the DC/DC converter.
J2-1	RING	2 wire port; RING wire (Ib is the current sunk into this pin).
J2-2	TIP	2 wire port; TIP wire (Ia is the current sourced from this pin).
J2-3	NC	No Connection.
J2-4	NC	No Connection.
J2-5	VX	Audio Out. This is the analog output signal (from Tip and Ring) to the Codec.
J2-6	VR	Audio In. Analog input signal from the Codec (which is output on Tip and Ring).
J2-7	NC	No Connection.

5. Electrical Characteristics

5.1. Absolute Maximum Ratings

	Parameter	Symbol	Min	Max	Unit
1	DC Supply Voltage	V_{CC}	-0.3	7.0	V
2	Maximum Power Dissipation, Off Hook @ 25 °C	P_{SLIC}		1.2	W
3	Storage Temperature	T_S	-40	+100	°C
4	Duty Cycle for RM(H)			33	%

5.2. Recommended Operating Conditions

Ver.	Parameter	Symbol	Min	Typ	Max	Unit
A	DC Supply Voltage	V_{CC}	3.1		5.5	V
B	DC Supply Voltage	V_{CC}	3.3		5.5	V
C	DC Supply Voltage	V_{CC}	4.0	5.0	5.5	V
	Operating Temperature	T_{OP}	0	25	70	$^{\circ}C$

5.3. DC Electrical Characteristics

	Ver.	Parameter	Symbol	Min	Typ	Max	Unit	Test Comments
1	A,B A,B C	Supply Current, on-hook @ 5.0V @ 3.3V @ 5.0V	I_{VPWR}		60 70 30	90 105 35	mA mA	CLI bias resistor not fitted
2	A	Supply current ringing @ 5.0V @ 3.3V	$I_{RINGING}$		330 350		mA mA	$R_{LOOP} = 0R$ Load = 1 REN
2	B	Supply current ringing @ 5.0V @ 3.3V	$I_{RINGING}$		240 220		mA mA	$R_{LOOP} = 0R$ Load = 1 REN
2	C	Supply current ringing @ 4.0V~5.5V	$I_{RINGING}$		170		mA	$R_{LOOP} = 0R$ Load = 1 REN
3	A	Supply current, off-hook @ 5.0V @ 3.3V	I_{ACTIVE}		290 360		mA mA	Load = 600R
3	B	Supply current, off-hook @ 5.0V @ 3.3V	I_{ACTIVE}		230 250		mA mA	Load = 600R
3	C	Supply current, off-hook @ 4.0~5.5V	I_{ACTIVE}		180		mA	Load = 600R
4		Supply current in power down	I_{PD}		7 5		mA mA	@ 5.0V @ 3.3V
5	A	Constant current feed to line @ 5.0V @ 3.3V	I_{LOOP}		31 26		mA mA	Load = 600R
5	B	Constant current feed to line @ 5.0V @ 3.3V	I_{LOOP}		24.5 20.5		mA mA	Load = 600R
5	C	Constant current feed to line @ 4.0V~5.0V	I_{LOOP}	18	23		mA	Load = 600R
6		Off-Hook detect @5.0V Output Low Voltage Output High Voltage	V_{OL} V_{OH}	4.5		0.5	V V	100uA max output (with 3.3k internal pull-up resistor)

QCX601 Low Power Ringing SLIC MODULE

7		Off-Hook detect @3.3V Output Low Voltage Output High Voltage	V_{OL} V_{OH}	2.8		0.5	V V	
8		Control Inputs, RFL, RM,25HZ Input Low Voltage Input High Voltage	V_{IL} V_{IH}	3.5		0.5	V V	@ 5.0V
			V_{IL} V_{IH}	2.0		0.5	V V	@ 3.3V
9		Control Inputs, RFL, RM,25HZ Input low current Input high curren	I_{IL} I_{IH}	-0.5 -0.5		0.5 0.5	mA mA	

5.4. AC Electrical Characteristics

	Ver	Parameter	Symbol	Min	Typ	Max	Units	Test Comments
1		Impedance			600		ohm	
2		Input Impedance at VR			60		kohm	
3		Output impedance at VX				10	ohm	
4		Ringing Capability at 40V _{rms}			3		phone	
5	A	Ringing voltage		125		145	Vp-p	Load = 1 REN @ 25Hz
5	B	Ringing voltage		115		140	Vp-p	Load = 1 REN @ 25Hz
5	C	Ringing voltage		110		135	Vp-p	Load = 1 REN @ 25Hz
6		Transmit gai(2 Wire to VX	G24		-6		dB	Off-Hook
7		Receive gain(VR to 2 Wire	G42	-0.75		6	dB	Off-Hook
8		Relative Gain. Referenced to 1kHz.		-0.5		0.5	dB	Over frequency range 300 to 3400 Hz
9		Return Loss	RL	16 18			dB	300 - 500 Hz 500Hz - 3400Hz
10		Transhybrid Loss	THL	12 21 16			dB dB dB	300-500Hz 500-2500Hz 2500-3400Hz
11		Load on VX			10		kohm	Coupling capacitor = 100nF

6. Typical Connection Diagram

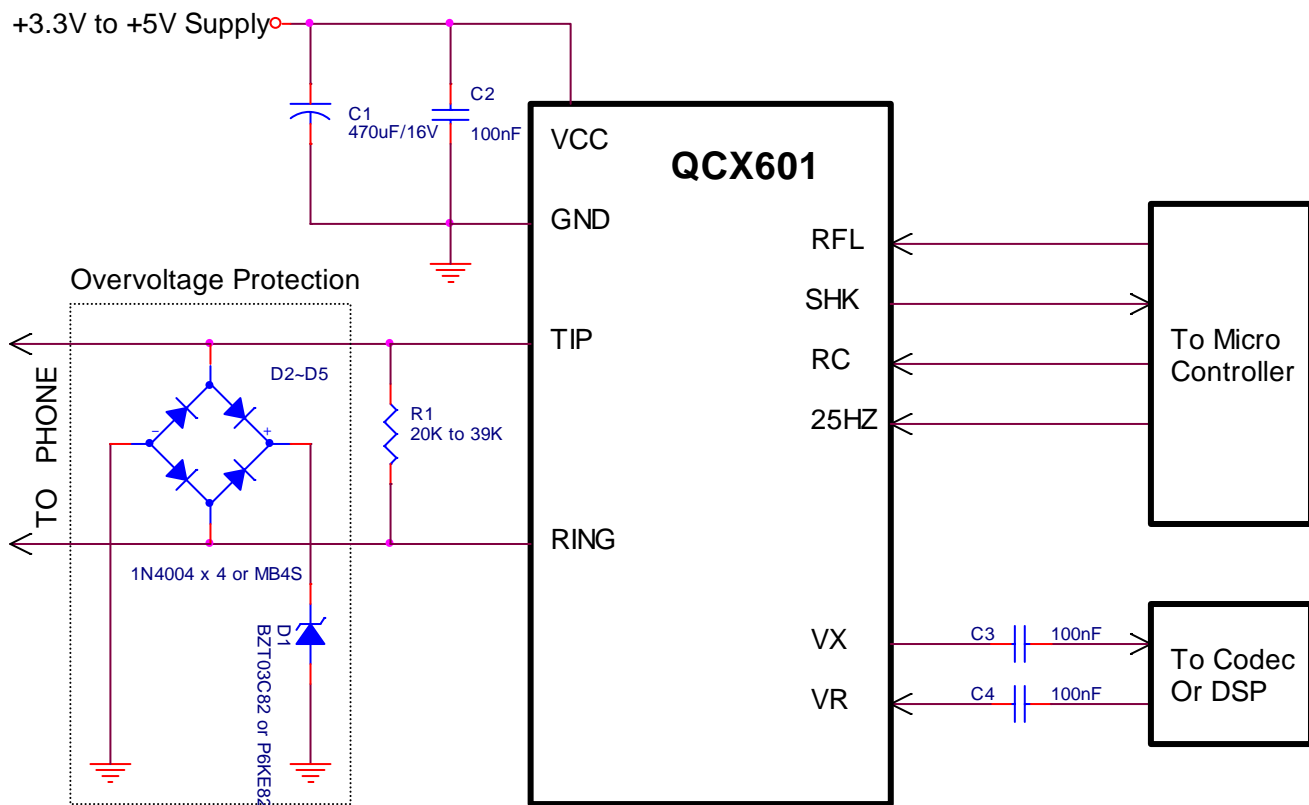

R1 = External DC bias resistor (required for CLI) typically 20K to 39K

The QCX601 is designed for use short loop “on-premise” applications, such as FCT, FWT, WLL and VoIP. In this case power cross and lightning protection is not required. The only protection which should be required is for ESD (Electro Static Discharge) caused by handling during installation.

7. Functional Description

7.1 Switch Hook Detection

When the subscriber goes “off-hook” loop current will begin to flow. If this current is above the detection threshold the switch hook output, SHK, will switch to a logic (H). It is recommended that software or hardware de-bouncing of the switch hook signal is used. This is to avoid short pulses which can cause a false switch hook output, triggering the incorrect system response.

During loop disconnect dialling, SHK will pulse between logic (H) and logic (L) to indicate the digits being dialled. Again it is recommended that software de-bouncing of the pulse edges is used to avoid false detection of digits

7.2 Tip & Ring Polarity Reversal

The QCX601 can reverse the battery voltage polarity at Tip and Ring via the RFL pin.

RC and 25HZ is at logic (L):

If RFL is held at logic (H) (Forward) the d.c. voltage at Ring is negative with respect to Tip.

If RFL is taken to logic (L) (Reverse) the voltage at Ring is positive with respect to Tip.

7.3 Ringing Signal Waveforms

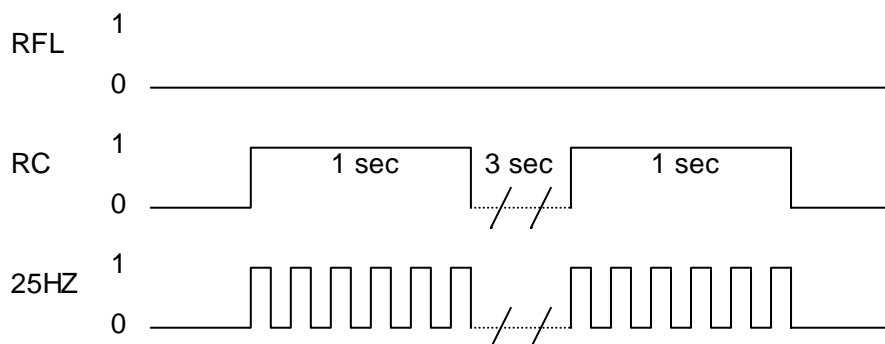

8. Package:

