

# UP

- a design guide line -

# 2/02

# E

# S

# O

# L

# C

## Electronics for Pyroelectric Detectors

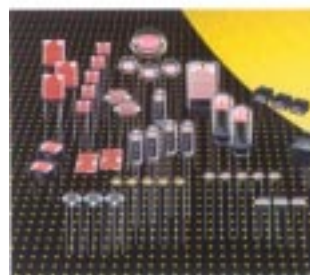
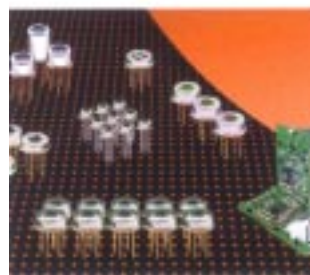
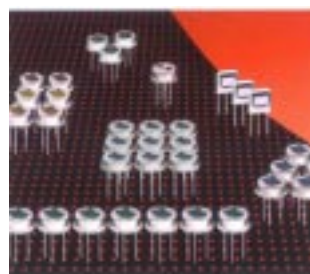

# Close Up

## Electronics for Pyroelectric Detectors for Motion Sensors

The frequency range of passive infrared detectors has been discussed in publ 1/02. With this follow up we take a close up towards the analog circuit design that will deal with the required frequency range.

Typical electronic circuits are made in discrete form with analog amplifiers, such as transistors

and most commonly, operational amplifiers. Trends for new developments will set the path for more integration of electronics into the detector case. A first step is to have detectors with built-in first amplifier stage. Further integration is foreseen for the next few years, in coordination with market requirements.

Most of the common motion sensors apply pyroelectric dual element detectors - see recommended type list below - in combination with a multisegment optical system.

Type	Kind	Application
LHi 878	dual element	Light switch
LHi 958	dual element	Standard intrusion alarm
LHi 968	dual element	High performance intrusion alarm
LHi 906	dual special element	Ceiling mount applications

The output of a standard detector ranges from 0.5 to 1 mV, pending from target temperature, background and distance, with a frequency range from 0.02 to 16 Hz, as discussed in 1/02 Close-Up. This signal has to be amplified prior further processing .

In some cases of wireless units where current consumption is critical, discrete transistors are designed in, but today most common is the use of operational amplifiers, even for low current applications, as there are special low power versions of op-amps are available.

In a usual DII package, up to four op-amps are offered by many suppliers. For the amplification of the signal we will need two stage of amplification.

The Detecor is operated in source follower mode, i.e. we need to supply a voltage to the 'Drain' connetion, and get the signal from the 'Source'pin, which requires a load resistor which is recommended to 47kOhm.

The two stage amplification 'kills two birds with one stone': it amplifies the signal and provides a bandpass to cut off noise signals outside the operating frequencies. What is the total amplification we would suggest to include?

Asuming we would prefer to continue Signal procesing in TTL level, the total amplification we require will be up to 10000. This needs to be done by two stages. Usually, amplifications of 3000 to 5000 are applied.

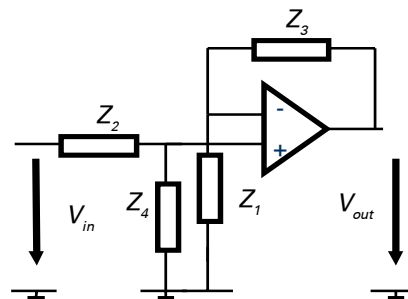

the 1st stage:

The first op-amp shall be used in the non-inverting mode. The advantage of this mode is to be independent from the op-amps internal resistance, no adaptation between Detector and amplifier is required.

The frequency range is set by the RC included, the amplification of the above circuit is calculated as

$$\frac{V_{out}}{V_{in}} = \frac{Z_4 (Z_1 + Z_3)}{Z_1 (Z_2 + Z_4)}$$

where Z1 to Z4 are the complex impedances of the RC combinations.

$$Z_{in} = Z_2 + Z_4$$

The second stage we may design in the standard inverting mode. To decouple the DC part of the amplified signal, we use RC coupling into the second stage, which also provides the frequency characteristic.

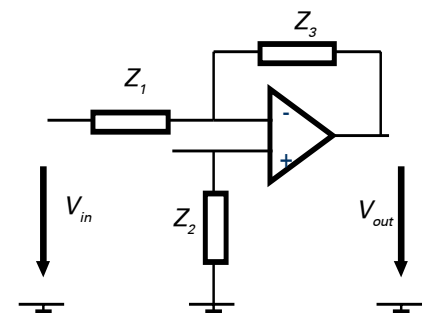

the 2nd stage:

Again, the frequency range is set by the RC included, the amplification of the above circuit is calculated as

$$\frac{V_{out}}{V_{in}} = \frac{Z_3}{Z_1} \quad Z_{in} = Z_1$$

We now have concluded in a two stage amplifier with frquency bandpass. Will we require additional parts? The load resistor for the detector has already been mentioned. We may add a 200nF capacitor or similar in parallel for RF protection. Further RF protection is the additional 1kOhm resistor in the 'Drain' connection, between supply voltage and detector.

The so designed circuit offers amplification at 1 Hz of 3100, or 70 dB, with bandbass 3 dB cut off frequencies of 0.28 Hz and 8.4 Hz.

An alternative connection of detecto to amplifiers is the use of the Detector Fet

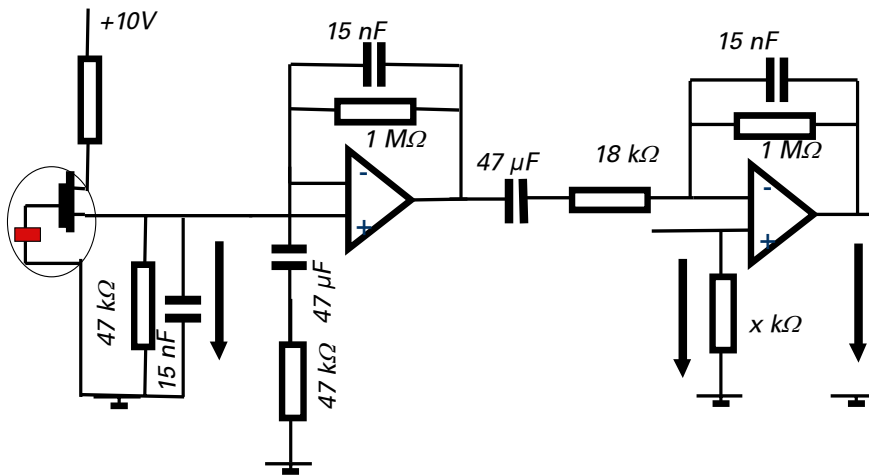

the complete amplifier circuit

as amplifier. The signal is derived as function of the current consumption of the detector, from the 'Drain' pin. This kind of circuit offers additional amplification of 12 dB. The disadvantage is that the inherent noise of the sensor is amplified as well, so the gain is negligible. And there is another disadvantage of this design: It is highly dependent on the characteristics of the detector FET and also on supply voltage.

is used to separate the motion signals from noise disturbances and air movements.

The amplified signal consists of an AC type voltage riding on a DC offset. This DC offset has to be fixed as reference levels for both the positive and negative amplitude.

magnetic interferences and mechanical shocks. The values of these are strongly depending on the voltage strengths and the force applied, but they may range up to 100 μV. We recognize: the detector inherent noise raises lesser concerns than other disturbances.

The trigger level shall reference the maximum of the considered disturbances, which in our example is 250 μV. This level we have to multiply with the amplification to get to the AC voltage for the comparator design.

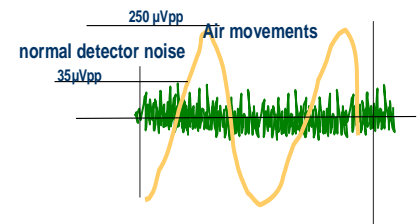

As we have already mentioned, the signal is referencing a DC offset. We fix this offset to a DC level of 4.0 V by a Zenerdiode connected to the non-inverting input. We now can calculate the trigger levels for the comparator as

$$\begin{aligned}
 V_{\text{Trigger}} &= V_{\text{Disturb}} \times \text{Amplification} \\
 &= 250\mu\text{V} \times 3100 \\
 &= 775 \text{ mV}
 \end{aligned}$$

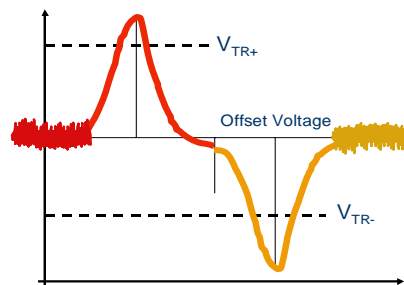

To fix the upper trigger voltage, again a Zenerdiode is recommended, with 4,7V value. The lower trigger voltage is divided by resistors in a voltage divider.

$$\begin{aligned}
 V_{\text{TrL}} &= V_{\text{Offset}} \pm V_{\text{Trigger}} \\
 &= 4\text{V} \pm 775 \text{ mV}
 \end{aligned}$$

$$V_{\text{TL+}} = 4,775 \text{ V} ; \quad V_{\text{TL-}} = 3,225 \text{ V}$$

The signal transformation from an AC voltage into a pulse signal is shown by the next two sketches:

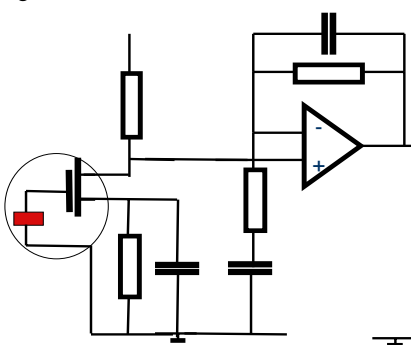

the alternative 1st stage:

As such the conclusion is that the alternative is not recommended and may only be chosen where no other option is available.

### The further signal processing:

Most of the current designs are of analog circuitry. In this case, a comparator

Let us shortly consider the requirements for the trigger level:

The level shall be such low to give the unit maximum detection range, and at the same time such high to be above all disturbances, What disturbances do we experience?

One of the basic factors is the inherent noise of the detector, which is about 50 μVpp. The next important disturbance is the movement of air in the monitored operation range. For outside operation, hot air movements may generate signals up to 250 μV, for inhouse operation it may be less, up to 180 μV.

Other possible disturbance are electro-

# CLOSE UP

The first sketch explains signal and trigger voltages and the window when the signal is exceeding the trigger levels.

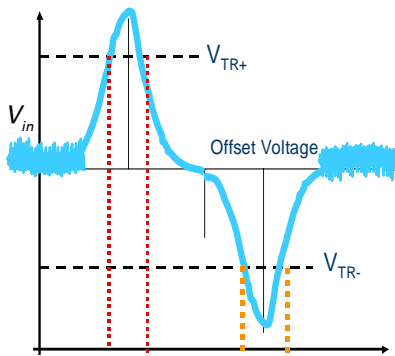

The second sketch shows the resulting output, which is in pulse form. Two pulses will be generated for the Signal mentioned in 1).

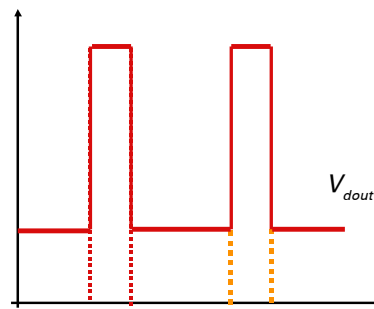

The iR detector's analog output signal is hereby transferred into a pulse signal, which can be used to either trigger a timer or send an alarm signal to central station, or to be copied into a microprocessor for further logic processing. This part of the circuitry is not discussed herein.

### Summary:

Based on working range and optical system we can determine the amplification requirements for motion sensor applications. We have discussed a simple and effective way to process the signal from analog AC into a pulsed output.

A simple circuit suggestion for the comparator is mentioned here using two operational amplifiers. The upper trigger level is set by the Zenerdiode as already explained. The output of the second stage amplifier can be directly coupled into the input of the comparator stage.

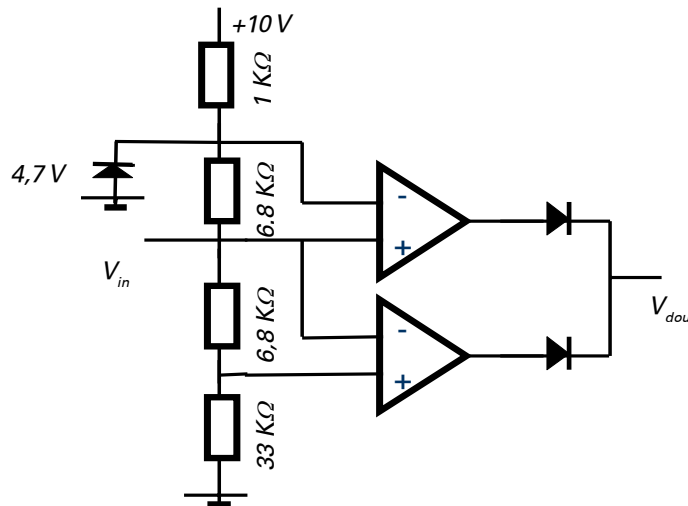

### Impressum:

Close up is a PerkinElmer Optoelectronics Application Paper, published by W Schmidt PerkinElmer Optoelectronics GmbH  
 PO Box 3007, 65020 Wiesbaden, Germany.  
 Close Up 2/02 Author W Schmidt  
 Copy or reprint only with permission.



Europe:  
**PerkinElmer** Optoelectronics GmbH  
 Wenzel Jaksch Str 31  
 Wiesbaden / Germany  
 Phone +49(0)611 492 0  
 Fax +49(0)611 492 170

USA:  
**PerkinElmer** Optoelectronics  
 2175 Mission College Blvd  
 Santa Clara, CA 95054  
 Phone +408 565 0830  
 Fax +408 565 0703

Asia:  
**PerkinElmer** Optoelectronics  
 47, Ayer Rajah Crescent #06-12  
 Singapore 139947  
 Phone +65 775 2022  
 Fax +65 775 1008