

Arduino UNO SPI	
13	SCK
12	MISO
11	MOSI
10	SS,CS

Libraris	
UTFT.h	oder
Adafruit_ILI9340	oder
Ucglib	

```
#include <Adafruit_GFX.h>
#include <TFT_ILI9340.h>
#include <SPI.h>
```

- 9 * SDO: Serial clock output
- 8 * LED: 3.4V Power Supply pin
- 7 * SCL: Serial clock input
- 6 * SDA / SDI: Serial data input
- 5 * DC: Data / Command selection
- 4 * RST: Reset, Low level active
- 3 * CS: Chip Selection, Low level active
- 2 * GND: Ground
- 1 * Vcc:5V or 3.3V Power Supply witch JP

Ansteuerung NUR über 5V->3V3 Pegelwandler!!! (CD5050)

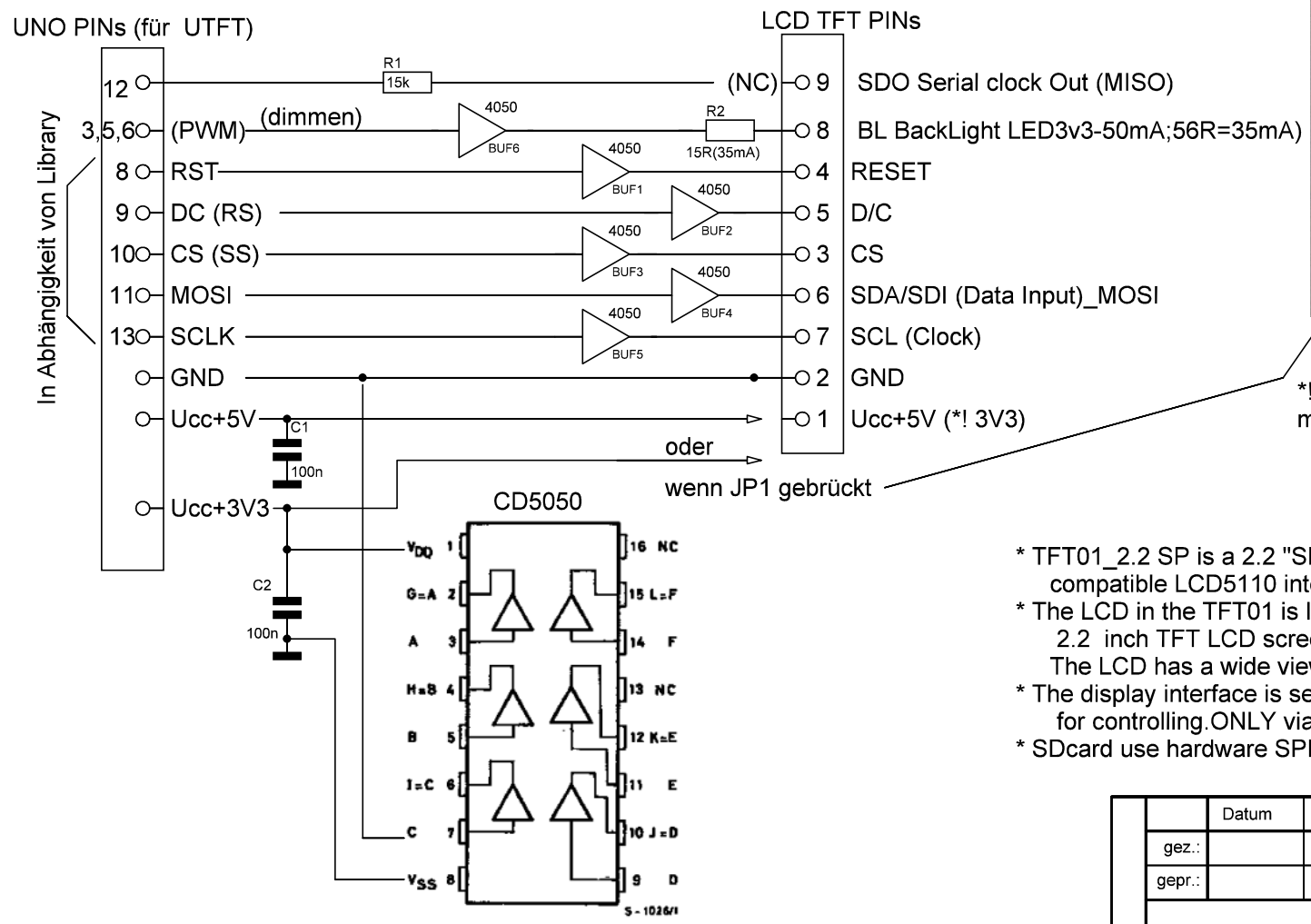

*! wird JP1 gebrückt, dann wird das Display mit 3V3 vom Arduino direkt versorgt.

- * TFT01_2.2 SP is a 2.2 "SPI TFT LCD Screen Module, 10pins interface, compatible LCD5110 interface. Not just a LCD break but include SD card (2GB),
- * The LCD in the TFT01 is ILI9341. It's a 240 * 320 (resolution), 2.2 inch TFT LCD screen.
- The LCD has a wide viewing angle, the contrast is also very suitable.
- * The display interface is serial, it just needs 5 wires (CS, RS, SCL, SDA, RST) for controlling. ONLY via CD4050 5V to 3V3 Levelshifter
- * SDcard use hardware SPI interface (CS / MOSI / MISO / SCK), Not solder pins.

	Datum	Name	Bezeichnung / Datei	Blattzahl:
gez.:			QVGA-22-TFT 240x320	
gepr.:				Blatt-Nr.:
			Zeichnungs-Nr.:	