

### Mikrocontroller - PIC16F18855

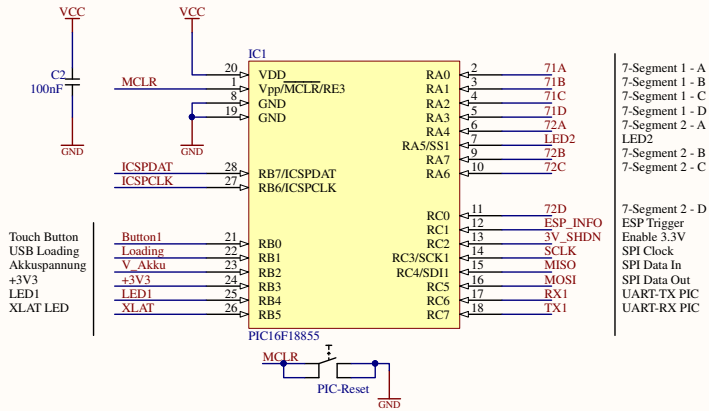

### ESP8266

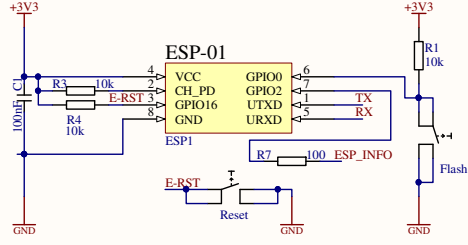

### Programmer

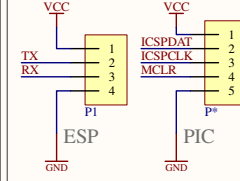

### Spannungsregler

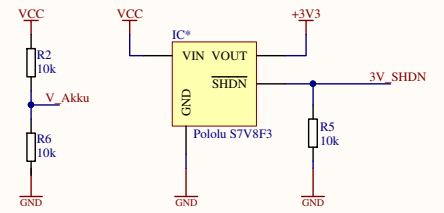

### 7-Segment-Anzeige

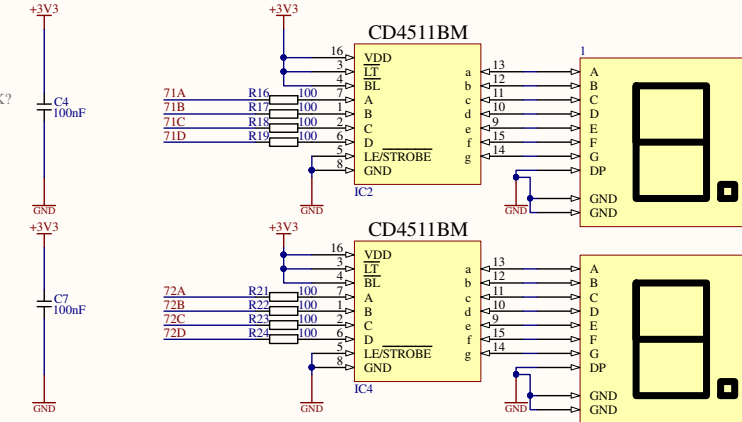

### Induktiver Button

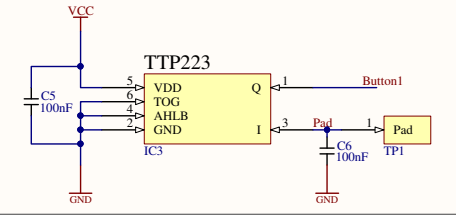

### Power

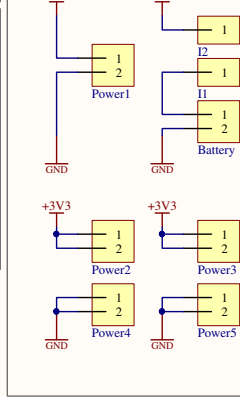

### Ladeschaltung Batterie

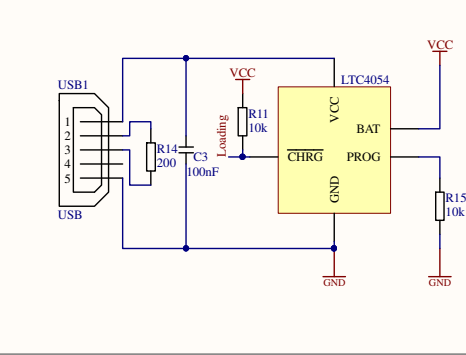

### UART-Jumper

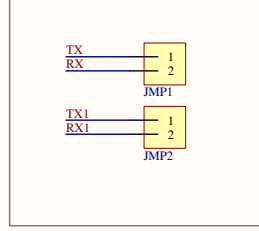

### LED

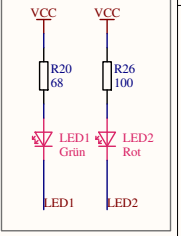

### LED-Treiber

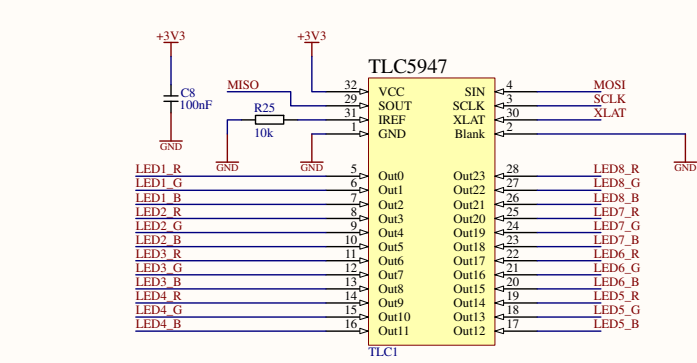

### RGB-LED

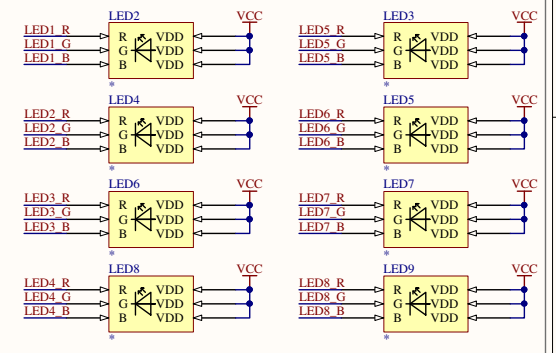

Title		
Size	Number	Revision
A3		
Date:	19.12.2017	Sheet of
File:	C:\Users\...VfiCube_v1.3.SchDoc	Drawn By: