



smart
positioning



REV 2.4

TECHNICAL DESCRIPTION

iTrax03 OEM GPS Receiver

This document describes the electrical connectivity and main functionality of the iTrax03 hardware

June 30, 2006

Fastrax Ltd.

TRADEMARKS

iTrax™, iSuite™, iCore™ and iTalk™ are trademarks of Fastrax Ltd.

VS_DSP™ is a trademark of VLSI Solution Oy.

Microsoft Windows NT®, Microsoft Windows 2000®, Microsoft Windows XP®, and Microsoft Visual C++® are registered trademarks of Microsoft® Corporation.

MATLAB® is a registered trademark of MathWorks, Inc.

All other trademarks are trademarks or registered trademarks of their respective holders.

CHANGE LOG

Rev.	Notes	Date
1.1	Preliminary documentation	2003-08-05
1.2	SPI2SDO I/O direction in 3.2	2003-08-28
1.3	Major update	2003-11-17
1.4	Updated I/O pin usage	2004-01-21
1.5	Updated I/O pin usage and application circuit	2004-02-02
1.6	Check by SW team	2004-05-27
1.7	Added moisture sensitivity information	2004-06-16
1.8	Contact 17 in page 13, modified chapter 6.1	2004-09-30
1.9	Wake-up, pin states, chapt. 4.6, ref. design	2004-12-02
2.0	Tables 3 & 4, chapt. 4.6.5, figures 6 & 7	2005-02-23
2.1	Added iTrax03 Application Board documentation	2005-09-01
2.2	Added pin description to chapter 6.	2005-09-06
2.3	Fixed some typing errors	2005-11-28
2.4	Added recommendations for wiring unused GPIO pins.	2006-6-30

CONTENTS

1.	GENERAL DESCRIPTION	7
1.1	Block diagram	7
1.2	Frequency Plan	8
2.	SPECIFICATIONS.....	9
2.1	General	9
2.2	Absolute maximum ratings.....	10
3.	OPERATION	11
3.1	Operating modes.....	11
3.2	Navigation/Idle mode	11
3.3	Sleep mode.....	11
3.4	Programming mode.....	12
4.	CONNECTIVITY	13
4.1	Connection assignments.....	13
4.2	Power supply (pins 18, 27)	16
4.3	Reset (pin 12)	17
4.4	Watchdog.....	17
4.5	Shared functionality.....	17
4.6	Dedicated GPIO	18
4.6.1	Boot Select (pin 16)	18
4.6.2	UI Indicators (pins 8, 9, 15).....	20
4.6.3	On/Off control input (pin 14).....	21
4.6.4	Wake-up input (pin 5)	21
4.6.5	[Power Good control input (pin 2) – NOT YET IMPLEMENTED].....	22
4.6.6	Sleep mode and I/O	22
4.7	Antenna input (pin 21)	24
4.7.1	Active GPS antenna.....	25
4.8	PPS output (pin 33).....	25
4.9	Serial ports	25
4.10	SPI-bus	25
4.11	Capture timers (pins 34, 37)	26
4.12	Pulse measurement inputs (pins 30, 31).....	26
4.13	MMC bus (pins 6, 8, 9).....	26
4.14	Mechanical dimensions and contact numbering.....	27

4.15	Suggested pad layout	28
4.16	Suggested Reflow soldering profile.....	29
5.	REFERENCE DESIGN	30
5.1	Minimum Application Circuit Diagram.....	30
5.2	Enhanced Application Circuit Diagram.....	32
5.3	PCB layout issues.....	33
6.	ITRAX03 APPLICATION BOARD	35
6.1	General	35
6.2	I/O Card Terminal connector	35
6.3	Bill of Materials	37
6.4	Application Board Circuit Drawing	38
6.5	Application Board, Components layout.....	39
6.6	Application Board, Artwork layer 1	39
6.7	Application Board, Artwork layer 2.....	40
6.8	Application Board, Artwork layer 3.....	40
6.9	Application Board, Artwork layer 4.....	41
7.	HANDLING INSTRUCTIONS.....	42
7.1	Moisture sensitivity and drying procedure.....	42
8.	PRODUCT LINE-UP	44
8.1	iTrax03/8 with 8 Mbit Flash memory	44
8.2	iTrax03/16 with 16 Mbit Flash memory	44

COMPLEMENTARY READING

The following reference documents are complementary reading for this document:

Ref. #	File name	Document name
1	PRO_NMEA.html	Fastrax NMEA Protocol Specification
2	uN8130T_UM.pdf	uN8130 User's manual

1. GENERAL DESCRIPTION

iTrax03 is a GPS receiver module for the OEM market segment. It integrates the GPS chip set from u-Nav Microelectronics: the RF down-converter uN8021 and the processor uN8130. The processor includes all base band functions needed for GPS signal acquisition, tracking and navigation. A dedicated high-performance search engine architecture enables a rapid search of visible satellites. A 12 channel tracking unit insures that positioning is possible even in severe conditions such as weak signals in urban canyons. The processor provides also an internal watchdog timer.

The iTrax03 module interfaces to the customer's application via a versatile I/O bus and supports several external devices including timers, pulse measurement inputs and an MMC bus. All the peripherals have a shared functionality with general purpose input/output (GPIO) signals.

The antenna input supports passive and active antennas and provides also an internal antenna bias supply.

This document describes the electrical connectivity and main functionality of the iTrax03 hardware.

1.1 Block diagram

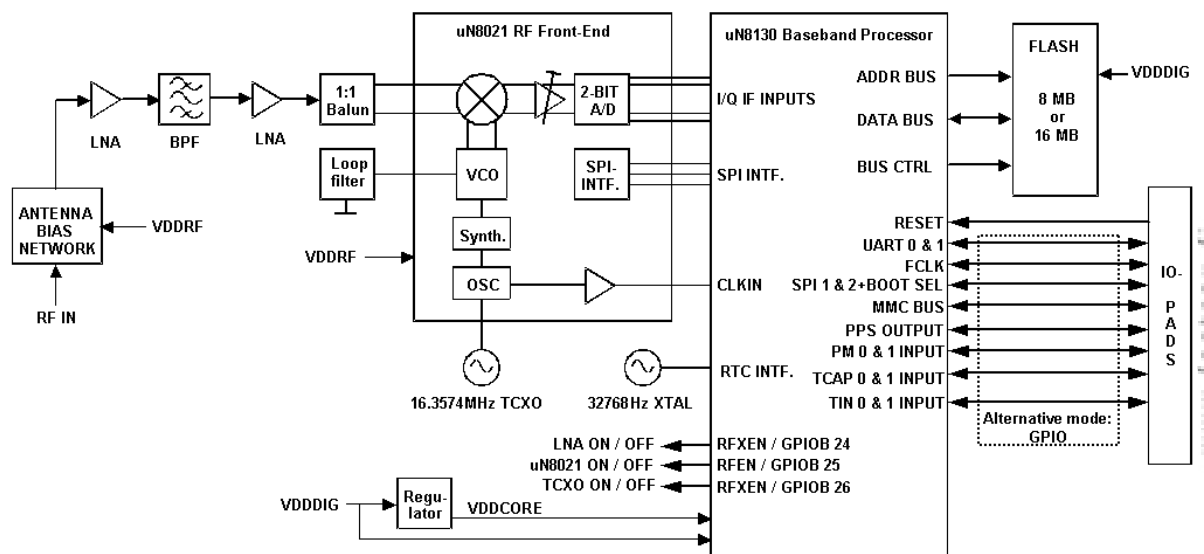

Figure 1 Block diagram

1.2 Frequency Plan

Clock frequencies generated internally at the iTrax03 receiver:

- 32768 Hz real time clock
- 16.3574 MHz master clock
- 1574.40 MHz local oscillator of the RF down-converter

2. SPECIFICATIONS

2.1 General

Table 1 General Specifications

Receiver	GPS L1 C/A-code, SPS
Channels	12
Update rate	< 5 Hz, 1 Hz (default).
Supply voltage range, VDDRF	+2.7V...+3.3 V, low ripple 2mV(RMS) max.
Supply voltage range, VDDDIG	+2.7V...+3.3 V
Power consumption	100 mW typical (without antenna bias)
Antenna net gain range	0...+32 dB
Antenna bias voltage	Same as VDDRF
Antenna bias current	Must be limited externally by VDDRF supply to 150mA max.
Operating and storage temperature	-40°C...+85°C
Serial port configuration	Port 0: NMEA (default), iTALK optional Port 1: iTalk
Serial data format	8 bits, no parity, 1 stop bit
Serial data speed	600, 1200, 2400, 4800, 9600, 14400, 19200, 28800, 38400, 57600, 115200, 230400, 460800, 921600 baud. NMEA: 4800(default), iTalk: 115200(default).
I/O signal levels	CMOS compatible: low state 0.0...0.3xVDDDIG; high state 0.7...1.0xVDDDIG
I/O sink/source capability per contact	+/- 4 mA max.
PPS modes	Off, Survey, Static, Roving (default)
Accessory I/O (shared functionality with GPIO)	2xCapture Timers, 2xPulse Measurement Inputs, 1xSPI-bus, MMC bus

2.2 Absolute maximum ratings

Table 2 Absolute maximum ratings

Item	Min	Max	unit
Operating and storage temperature	-40	+85	°C
Power dissipation		500	mW
Supply voltage, VDDDIG	-0.3	+3.6	V
Supply voltage, VDDRF	-0.3	+3.6	V
Current on any I/O pin except antenna input	-30	+30	mA
Current output on antenna input	0	+100	mA
Input voltage on any input connection	-0.3	VDDDIG + 0.3	V

3. OPERATION

3.1 Operating modes

After power-up iTrax03 boots from the internal Flash memory for normal operation. Modes of operation:

- Navigation/Idle mode
- Sleep mode
- Programming mode

3.2 Navigation/Idle mode

The iTrax03 receiver enters Navigation mode after it has powered up. By default it will start navigation automatically after power-up or reset in Auto Start mode. Auto Start mode means that all available aiding information will be used.

The module operates as long as the power supply is available.

Idle mode means that the navigation is stopped but the processor remains active. Navigation/Idle mode is also referred as **Normal Mode**.

The standard firmware supports versatile configuration of various operating configurations, e.g. Logging position data etc., for further details see *ref 1*.

The navigation can be stopped by sending a proper NMEA or iTALK message, see also *ref 1*.

3.3 Sleep mode

The Sleep mode means low power operation during which no other activity other than the internal real time clock (RTC) is present. The module enters Sleep mode via a special control message (*ref #1*) or by the On/Off Control input.

The exit from the Sleep mode to the Normal mode happens in the following situations:

- an elapsed time
- an RS-232 break signal or a dummy input character to selected serial port (the low input state should exceed 20ms)
- an interrupt from the On/Off Control input (low-to-high transition)
- an interrupt from the Wake-up input (low/high or high/low transition).

Since the internal RTC keeps the GPS time estimate, the module performs the fastest possible navigation start depending on the availability of valid satellite/position data.

3.4 Programming mode

The module enters Programming mode by two methods: HW-booting or upgrading the firmware on-the-fly by a dedicated NMEA or iTalk command, see *ref 1*.

The on-the-fly upgrading requires only the serial Port 0. The downloading will start by sending a special serial port command, after which the utility running on the host will send the new firmware to the processor.

HW-booting is utilized by keeping the Boot Select input (pin 16, SPI2XCS3/ GPIOB22) at logic low during power-up or system reset. Now the GPS module boots from the serial data Port 0, sends hex 55 (U) string at 9600 baud and waits for the boot loader commands from the host (an application running on the host). This mode is required when there is no existing firmware stored into the internal Flash memory.

It is recommended to support hardware based re-programming (HW-booting) in an iTrax03 application. This is done by adding Boot Select and XRESET control inputs into the design. See the reference design.

4. CONNECTIVITY

4.1 Connection assignments

The I/O connections are available as soldering pads on the bottom side of the module. These pads are also used to attach the module on the motherboard in the application. All unused I/O pins should be left open (floating), except GPIOB15 (GND) and GPIOB18 (HIGH).

Table 3 Full system connection description of iTrax03. Some pins can function as GPIO pins or in a special mode depending on the software configuration.

Pin	Signal name	I/O	Alternative GPIO name	Signal description
1	GND	-	-	Ground
2	SPI1XCS0	O	GPIOB10	SPI1 chip select 0, <i>GPIO reserved for future use. Do not connect.</i>
3	SPI1CLK	O	GPIOB13	SPI1 clock
4	SPI1SDO	O	GPIOB14	SPI1 data output
5	SPI1SDI	I	GPIOB15	SPI1 data input, Wake-up input
6	MMCCLK	O	GPIOA12	MMC clock output
7	GND	-	-	Ground
8	MMCCMD	I/O	GPIOA13	MMC command bus, UI indicator B
9	MMCDAT	I/O	GPIOA14	MMC data bus, UI indicator A
10	GND	-	-	Ground
11	SPI2CLK	I/O	GPIOB16	SPI2 clock, output in master mode
12	XRESET	I	-	Active low async. system reset
13	GND	-	-	Ground
14	SPI2SDI	I	GPIOB18	SPI2 data input, On/Off control input
15	SPI2SDO	O	GPIOB17	SPI2 data output, UI indicator C

16	SPI2XCS3	I/O	GPIOB22	SPI2 chip select3, Boot Select
17	SPI2XCS2	O	GPIOB21	SPI2 chip select2, (2nd boot select)
18	VDDRF	I	-	VDD for RF circuits
19	GND	-	-	Ground
20	GND	-	-	Ground
21	RFIN	I	-	RF input, antenna bias output
22	GND	-	-	Ground
23	TXD1	O	GPIOA3	UART 1 async. output
24	RXD1	I	GPIOA2	UART 1 async. input
25	TXD0	O	GPIOA1	UART 0 async. output
26	GND	-	-	Ground
27	VDDDIG	I	-	VDD for digital circuits
28	RXD0	I	GPIOA0	UART 0 async. input
29	FCLK	O	GPIOA4	Pre-divided clock output of UART 1
30	PM0	I	GPIOA5	Pulse measurement input 0
31	PM1	I	GPIOA6	Pulse measurement input 1
32	GND	-	-	Ground
33	PPS	O	GPIOA7	1PPS signal output
34	TCAP0	I	GPIOA9	Timer TMG0 capture input
35	TIN0	I	GPIOA8	Timer TMG0 external clock input
36	TIN1	I	GPIOA10	Timer TMG1 external clock input
37	TCAP1	I	GPIOA11	Timer TMG1 capture input
Pin	Signal name	I/O	Alternative GPIO name	Signal description

Table 4 System connection pin modes for iTrax03 in the default firmware configuration (Normal mode).

Pin	Pin mode	I/O	GPIO mode	Default signal description
1	GND	-	-	Ground
2	GPIOB10	I	Pull-up	<i>Reserved for future use. Do not connect.</i>
3	GPIOB13	I	Pull-down	<i>No specific function</i>
4	GPIOB14	I	Pull-down	<i>No specific function</i>
5	GPIOB15	I	Pull-down	Wake-up input
6	GPIOA12	O	Push-pull	Debug LED 8 output
7	GND	-	-	Ground
8	GPIOA13	O	Push-pull	UI indicator B
9	GPIOA14	O	Push-pull	UI indicator A
10	GND	-	-	Ground
11	GPIOB16	I	Pull-down	<i>No specific function</i>
12	XRESET	I	-	Active low async. system reset
13	GND	-	-	Ground
14	GPIOB18	I	Pull-up	On/Off control input
15	GPIOB17	O	Push-pull	UI indicator C (Fix available)
16	GPIOB22	I	Pull-down	Boot Select during power-up and reset
17	GPIOB21	I	Pull-down	2nd boot select during power-up and reset
18	VDDRF	I	-	VDD for RF circuits
19	GND	-	-	Ground
20	GND	-	-	Ground
21	RFIN	I	-	RF input, antenna bias output
22	GND	-	-	Ground

23	TXD1	O	-	UART 1 async. output
24	RXD1	I	-	UART 1 async. input
25	TXD0	O	-	UART 0 async. output
26	GND	-	-	Ground
27	VDDDIG	I	-	VDD for digital circuits
28	RXD0	I	-	UART 0 async. input
29	GPIOA4	O	Push-pull	Debug LED 1 output
30	GPIOA5	O	Push-pull	Debug LED 2 output
31	GPIOA6	O	Push-pull	Debug LED 3 output
32	GND	-	-	Ground
33	PPS	O	-	1PPS signal output
34	GPIOA9	O	Push-pull	Debug LED 5 output
35	GPIOA8	O	Push-pull	Debug LED 4 output
36	GPIOA10	O	Push-pull	Debug LED 6 output
37	GPIOA11	O	Push-pull	Debug LED 7 output
Pin	Pin mode	I/O	GPIO mode	Signal description

4.2 Power supply (pins 18, 27)

The iTrax03 module requires two separate power supplies: VDDRF for the RF parts and VDDDIG for digital parts and I/O bus.

VDDRF must be linearly regulated having a low ripple 2mV(RMS) max. The typical current drain is 24 mA in Normal (Navigation) mode. Note that VDDRF is also provided internally at the antenna input as an active antenna bias.

NOTE

VDDRF supply current should be limited externally below 150 mA max.

NOTE

VDDRF supply voltage should have a low ripple 2mV(RMS) max.

The VDDDIG supply may be shared with any available supply that meets the specified voltage range. A typical current is 12 mA in Normal (Navigation) mode but it may peak up to 40 mA for short durations. The VDDDIG supply voltage ripple should be below 40mV (RMS).

4.3 Reset (pin 12)

The system reset input (pin 12, XRESET), is an active low asynchronous reset. The processor boots after an XRESET low-to-high transition. The XRESET input contains a 100k ohm pull-up resistor, an open-source power-on-reset (POR) circuit and a Schmitt trigger in order to eliminate the effect of noise. The POR is connected in parallel with the XRESET input and it overrides XRESET during power-up.

For normal operation the XRESET input can be left unconnected. The module will independently handle the reset during power-on. However, to enable the hardware re-programming, it is advisable to connect the XRESET input for example to an open-collector or an open-source control output.

4.4 Watchdog

The processor contains a watchdog peripheral, which resets the processor if not refreshed frequently enough. Basically the watchdog is a 16-bit counter with enabling, disabling and restarting controls. The watchdog counter is clocked with the frequency of 128 Hz.

4.5 Shared functionality

All the I/O pins have a shared functionality. These pins can be programmed either to have a special function (PM, SPI, MMC etc.) or a general purpose I/O (GPIO) function.

Each signal is named according to the special functionality but also the secondary functionality is listed as Alternative GPIO in Table 3.

With the standard firmware there are dedicated GPIO connections, which are: Boot Select, UI Indicators and the control inputs. These shall be described in the following chapters.

4.6 Dedicated GPIO

4.6.1 Boot Select (pin 16)

The boot source is defined in the internal boot ROM sector by using pins 16 (GPIOB22 / SPI2XCS3) and 17 (GPIOB21 / SPI2XCS2). After a power-up or a system reset these pins are internally configured to a 100k ohm pull-down mode for 300 clock cycles (10 μ s), after which their logic states are read. Thus, if there is nothing connected to pin 16 or 17, these pins will be pulled low and the software will be loaded from UART Port 0. The boot source (internal Flash memory, UART Port 0 or SPI1 bus) is processed according to Table 5.

For normal module operation pin 16 must be pulled high to VDDDIG with a 10k ohm pull-up resistor. Pin 17 can be left floating.

Pin 16 is referred as Boot Select in this document. It should be connected in the application in order to enable the hardware based re-programming.

Table 5 Boot source selection

Pin 16	Pin 17	I/O	Boot source
High	High	I	External boot sector (Flash), in case of failure continue with SPI1 boot
High	Low	I	External boot sector (Flash), in case of failure continue with UART Port 0 boot
Low	High	I	SPI1 boot
Low	Low	I	UART Port 0 boot

Normally, after XRESET low-to-high transition, the appropriate boot selection should be kept active for at least 30 μ s. However, after connection of VDDDIG and VDDRF, the desired boot selection should be kept active for at least 100 ms. This is due to the internal POR delay on the XRESET signal.

The standard firmware supports only internal Flash memory or UART Port 0 as suitable boot sources. Thus only Boot Select (pin 16, SPI2XCS3/GPIOB22) is needed for proper boot selection setting.

NOTE

To ensure normal operation during system reset and power on, the Boot Select (pin 16, SPI2XCS3 / GPIOB22) requires an external pull-up resistor connected to VDDDIG, e.g. 10 kohm.

Respectively, pin 17 (SPI2XCS2 / GPIOB21) should be left open or connected to a pull-down resistor (e.g. 10 kohm).

4.6.2 UI Indicators (pins 8, 9, 15)

The standard firmware includes three GPIO outputs reserved as drivers for User Interface (UI) Indicators. These outputs can be used for example to drive LEDs, which give information on the state of the receiver.

Table 6 UI Indicators

UI Indicator	Pin number	I/O	Operation: High ratio %	Signal description
A	9	O	Continuously low state	Power Off or Sleep mode
A	9	O	Short blink 20	Normal mode, Navigation stopped
A	9	O	Long blink 80	Normal mode, Navigation started
B	8	O	Continuously low state	Navigation stopped or not tracking satellites
B	8	O	Short blink 20	Tracking satellites but not enough information to calculate pseudoranges
B	8	O	Long blink 80	Pseudorange information available but not navigating
B	8	O	Continuously high state	Navigating, Valid fix
C	15	O	Low state	No valid fix
C	15	O	High state	Valid fix available

The UI Indicators are updated synchronously at 1 Hz rate. The high state duty cycle is either 0% (i.e. continuously logic low), 20% (Short blink), 80% (Long blink) or 100% (i.e. continuously logic high).

Pin 15 (SPI2SDO / GPIOB17) indicates when a fix is available: the pin is logic high when a valid location fix is available, and logic low when the location fix is not available.

4.6.3 On/Off control input (pin 14)

With the standard firmware the module can be commanded to Sleep mode by the On/Off control input (pin 14, SPI2SDI / GPIOB18) or by a specific command. During Sleep mode only the real time clock is running and the current consumption is reduced to about 20 uA.

Note that the worst case delay from the On/Off Control high-to-low transition to achieve Sleep mode and reduced current drain is 300 ms. The standard firmware stores the last known good position (LKG) and any Log data to the internal Flash memory before entering the Sleep mode.

Table 7 On/Off control

On/Off Control, pin 14	I/O	Signal description
High state	I	Normal (navigating) mode, delay from Sleep mode 3 ms
Low state	I	Sleep mode, delay from Normal mode 300 ms max.

NOTE

With the standard firmware the On/Off control input (pin 14, SPI2SDI / GPIOB18) has an internal 100k ohm pull-up resistor connected to VDDDIG and the signal can be left unconnected for normal operation.

4.6.4 Wake-up input (pin 5)

The Wake-up input (pin 5, SPI1SDI / GPIOB15) wakes up the GPS processor from the Sleep mode. The pin transition can be either low-to-high or high-to-low.

4.6.5 [Power Good control input (pin 2) – NOT YET IMPLEMENTED]

NOTE: *The current software does not support Power Good input. This feature may be implemented in the future. For the time being, the pin 2 should be left floating.*

The standard firmware supports also the fastest possible entering to Sleep mode by Power Good control input (pin 2, SPI1XCS0 / GPIOB10).

Note that the worst case delay from the Power Good control high-to-low transition to achieve Sleep mode and reduced current drain is 200 μ s. The firmware **does not** store the last known good position (LKG) nor any Log data to the internal Flash memory before entering the Sleep mode. Only the internal RAM memory content can be retained by keeping VDDRF and VDDDIG active.

Table 8 Power Good control

Power Good Control pin 2	I/O	Signal description
High state	I	Normal (navigation) mode, delay from Sleep mode 3 ms
Low state	I	Sleep mode, delay from Normal mode 200 μ s max.

NOTE

With the standard firmware the Power Good control input (pin 2, SPI1XCS0 / GPIOB10) has an internal 100k ohm pull-up resistor connected to VDDDIG and the signal can be left unconnected for normal operation.

4.6.6 Sleep mode and I/O

During the Sleep mode almost all the I/O pins are configured as inputs with internal 100k ohm pull-down resistors. In order to reduce current leakage there are few exceptions, see Table 9.

Table 9 Pin states of iTrax03 in Sleep mode, when using default firmware.

Pin	Pin mode	I/O	GPIO mode	Signal description
1	GND	-	-	Ground
2	GPIOB10	I	Pull-down	GPIO input, 100k ohm pull-down
3	GPIOB13	I	Pull-down	GPIO input, 100k ohm pull-down
4	GPIOB14	I	Pull-down	GPIO input, 100k ohm pull-down resistor
5	GPIOB15	I	Pull-down	GPIO input, 100k ohm pull-down
6	GPIOA12	I	Pull-down	GPIO input, 100k ohm pull-down
7	GND	-	-	Ground
8	GPIOA13	I	Pull-down	GPIO input, 100k ohm pull-down
9	GPIOA14	I	Pull-down	GPIO input, 100k ohm pull-down
10	GND	-	-	Ground
11	GPIOB16	I	Pull-down	GPIO input, 100k ohm pull-down
12	XRESET	I	-	Active low async. system reset
13	GND	-	-	Ground
14	GPIOB18	I	Pull-down	GPIO input, pull-down (Stays as pull-up if NMEA Sleep command was used in Normal mode.)
15	GPIOB17	I	Pull-down	GPIO input, 100k ohm pull-down
16	GPIOB22	I	Pull-down	GPIO input, 100k ohm pull-down
17	GPIOB21	I	Pull-down	GPIO input, 100k ohm pull-down
18	VDDRF	I	-	VDD for RF circuits
19	GND	-	-	Ground

20	GND	-	-	Ground
21	RFIN	I	-	RF input, antenna bias output
22	GND	-	-	Ground
23	GPIOA3	I	Pull-up	GPIO input, 100k ohm pull-up
24	GPIOA2	I	Pull-up	GPIO input, 100k ohm pull-up
25	GPIOA1	I	Pull-up	GPIO input, 100k ohm pull-up
26	GND	-	-	Ground
27	VDDDIG	I	-	VDD for digital circuits
28	GPIOA0	I	Pull-up	GPIO input, 100k ohm pull-up
29	GPIOA4	I	Pull-down	GPIO input, 100k ohm pull-down
30	GPIOA5	I	Pull-down	GPIO input, 100k ohm pull-down
31	GPIOA6	I	Pull-down	GPIO input, 100k ohm pull-down
32	GND	-	-	Ground
33	GPIOA7	I	Pull-down	GPIO input, 100k ohm pull-down
34	GPIOA9	I	Pull-down	GPIO input, 100k ohm pull-down
35	GPIOA8	I	Pull-down	GPIO input, 100k ohm pull-down
36	GPIOA10	I	Pull-down	GPIO input, 100k ohm pull-down
37	GPIOA11	I	Pull-down	GPIO input, 100k ohm pull-down
Contact	Pin mode	I/O	GPIO mode	Signal description

4.7 Antenna input (pin 21)

The module supports passive and active antennas. The antenna input impedance is 50 ohms. The input provides also a bias supply during normal navigation operation. The antenna bias voltage is the same as the VDDRF supply.

In the Sleep mode the antenna bias voltage is cut off internally.

The maximum tolerated antenna bias current is 100mA. It is current limited only by the external regulator supplying VDDRF. The VDDRF supply current should be externally limited to 150 mA max.

NOTE

Passive antennas with a short-circuit to GND should be DC blocked externally.

4.7.1 Active GPS antenna

The customer may use an external active GPS antenna for e.g. in mobile or indoor usage. It is suggested the active antenna has a net gain *including cable loss* in the range from +6 dB to +32 dB.

4.8 PPS output (pin 33)

The PPS output provides a pulse-per-second signal, which can be used for timing purposes. The default PPS mode is Roving, i.e. timing pulse is available after valid fix based on the current valid fix position. The operating mode, pulse length and polarity are configurable via NMEA or iTALK. Other modes are Static, Survey and Off, see *ref 1* for details.

4.9 Serial ports

The device supports UART communication via Port 0 (RXD0 & TXD0) and Port 1 (RXD1 & TXD1). With the standard firmware Port 0 is configured to NMEA by default and secondary to iTALK protocol. Port 0 is also used when the device is booting from the serial port. With the standard firmware Port 1 is configured for iTALK communication by default and secondary to RTCM.

The serial port logic levels are CMOS compatible. Thus, they are not directly compatible with RS-232 logic levels. Use an external level converter to provide RS-232 levels, if needed. Refer to *ref 1* for supported data speeds.

4.10 SPI-bus

The SPI1 is reserved internally for the RF-down-converter and externally for a custom boot mode. Only the SPI2 device (master) is available for SDK users enabling SPI communication.

4.11 Capture timers (pins 34, 37)

Two general-purpose timers are available for SDK users with a custom firmware. TMG0 and TMG1 have configurable prescalers and clock cycle counts. The clock input is selectable between three sources and there is a capture mode to count external events. Each timer also has a programmable delay, referenced to the internal epoch pulse (TME). This makes it possible to have a specified delay between interrupts generated by the internal TME epoch, TMG0, and TMG1. For details see *ref 2*.

4.12 Pulse measurement inputs (pins 30, 31)

The two pulse measurement (PM) inputs are available for SDK users with a custom firmware. PM inputs can be used to measure with great accuracy how long an input stays high or low. For details see *ref 2*.

4.13 MMC bus (pins 6, 8, 9)

The MMC bus is available for SDK users with a custom firmware. The MMC unit implements a standard 3-wire Multi Media Card serial bus interface and provides control and data register for easy usage of the bus. Both stream and block mode data transfers are supported. The CRC is calculated automatically for transmitted commands and data blocks, also received responses and data blocks are checked for correct CRC. The MMC unit has a 64-bit data buffer and is capable of stopping bus clock to prevent buffer overflow and underflow situations. For details see *ref 2*.

4.14 Mechanical dimensions and contact numbering

Board size is 21.6mm (width) x 23.3mm (length) x 3.1mm (height max). General tolerance is ± 0.1 mm.

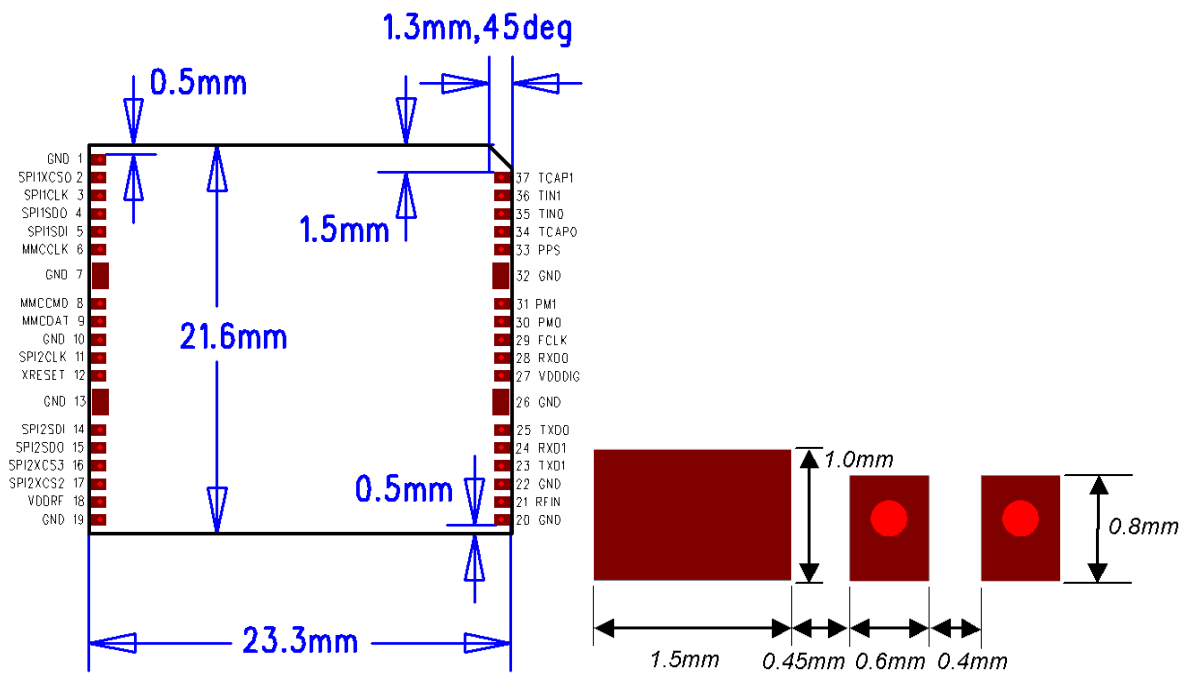

Figure 2 Contact numbering, top view through the package.

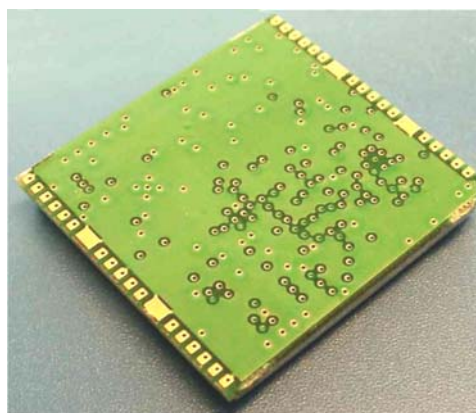

Figure 3 Bottom view of the iTrax03 module.

4.15 Suggested pad layout

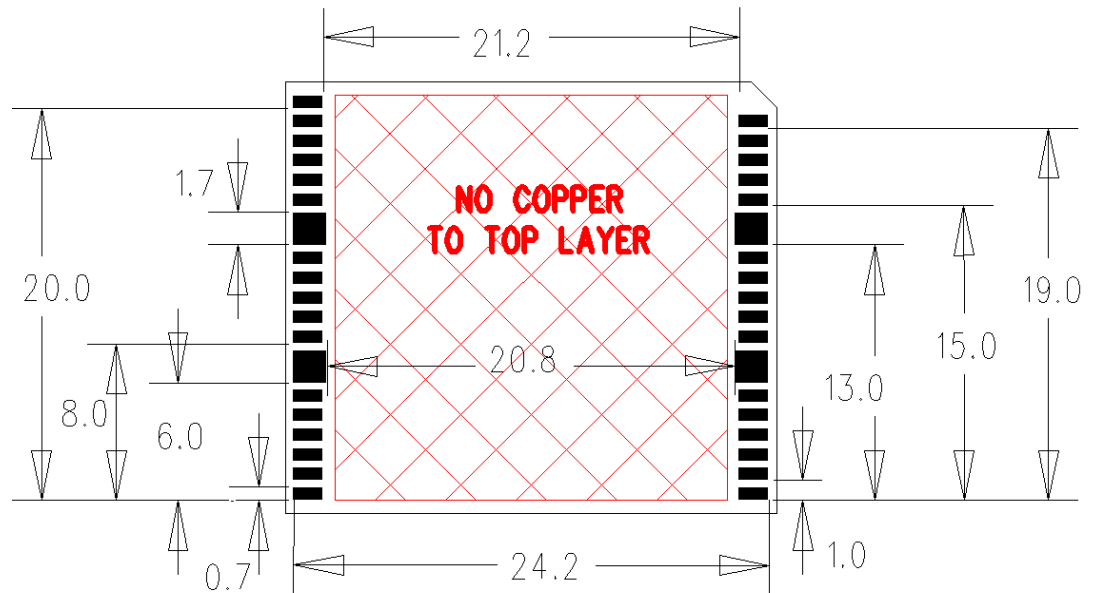

Figure 4 Suggested pad layout, top view through the package.
Dimensions are in *mm*.

4.16 Suggested Reflow soldering profile

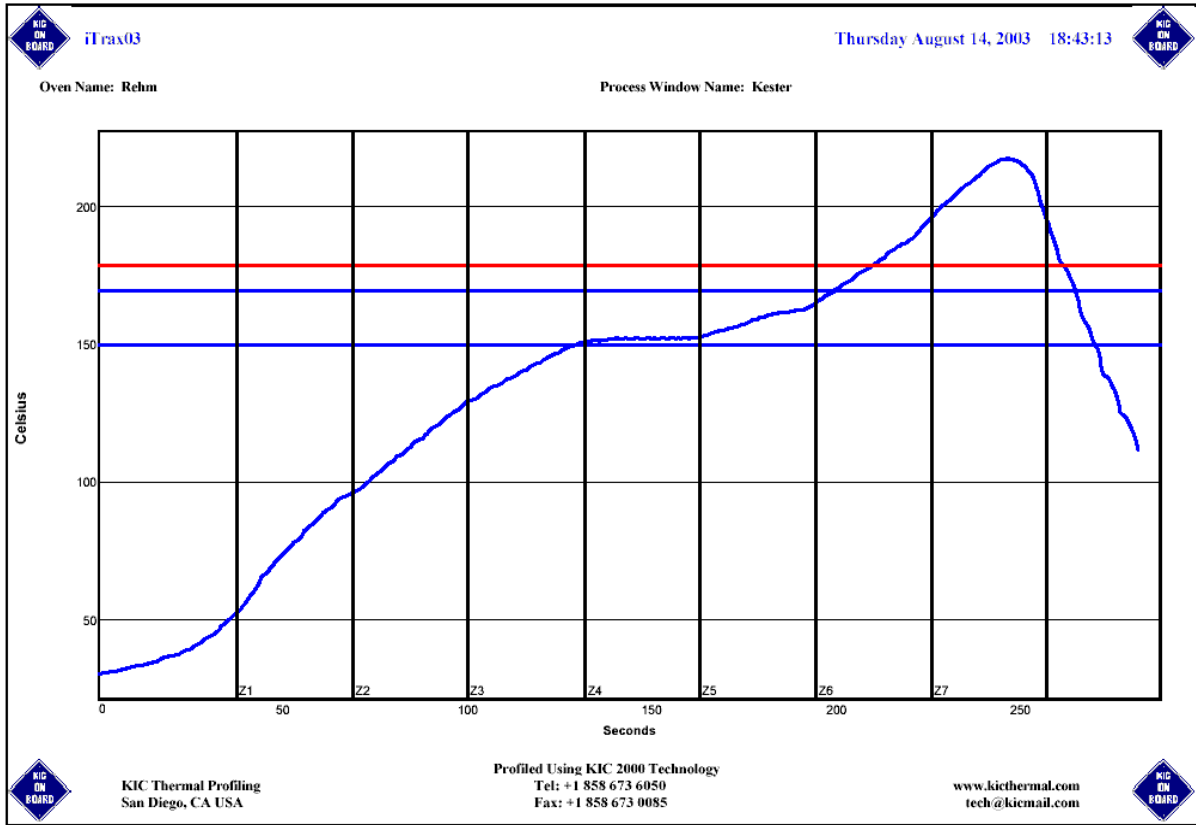

Figure 5 Suggested reflow soldering temperature profile.

5. REFERENCE DESIGN

The idea of the reference design is to give a guideline for the applications using the iTrax03 GPS module.

In the following two chapters the reader is exposed to design rules he should follow, when designing an iTrax03 based application. By following the rules one ends up having an optimal design with no unexpected behavior caused by the PCB itself. In fact these guidelines are quite general in nature, and can be utilized in any PCB design related to RF techniques or high speed logic.

5.1 Minimum Application Circuit Diagram

The Minimum Application supports communication through the UART Port 0 (NMEA or iTALK). Other required signals are the antenna input, supply voltages for VDDRF and VDDDIG and a pull-up resistor for the Boot Select.

Also, it is a good practice to make the iTrax03 application to support hardware based re-programming of the module firmware. Due to this, one should connect Boot Select (pin 16, SPI2XCS3 / GPIOB22) in such a way, that it can be toggled to logic low for a firmware update through serial Port 0. In normal operation Boot Select is pulled high with a resistor (R1 in Figure 6). iTrax03 supports also software based “on-the-fly” programming. This does not require toggling of the Boot Select signal. However, this method is not completely protected against unexpected problems during the re-programming session. Because of this, the use of Boot Select in the design is recommended.

The low drop-out linear regulator (LDO) U2 supplies +2.8 V voltage to the RF and analog parts (VDDRF) and the digital supply (VDDDIG) is taken directly from the main supply, which in this case is from +3.0 to +3.3 V due to the small drop-out voltage across U2. The linearly regulated power supply is needed for VDDRF, because the maximum allowed ripple voltage for VDDRF is 2 mV(RMS). The external regulator U2 can be omitted, if such a supply is available that meets the specified ripple voltage.

All the digital signals are routed away from the module through series resistors (R2, R3). In this way the local oscillator (LO) signal leakage that is present in the I/O contacts of the GPS module is suppressed. Although the LO leakage is very small at the I/O contacts of the

module, it may still interfere with the GPS reception, especially when the antenna is located very near to these signal routes.

For the same reason capacitors C1 and C2 should be connected very close to the module with short traces to I/O contacts and to ground plane.

Additionally, there must be another capacitor (C3: 4.7uF or bigger) from VDDDIG to the ground. This capacitor can be located further away. If a signal from the iTrax03 is not needed, the corresponding pin can be left open.

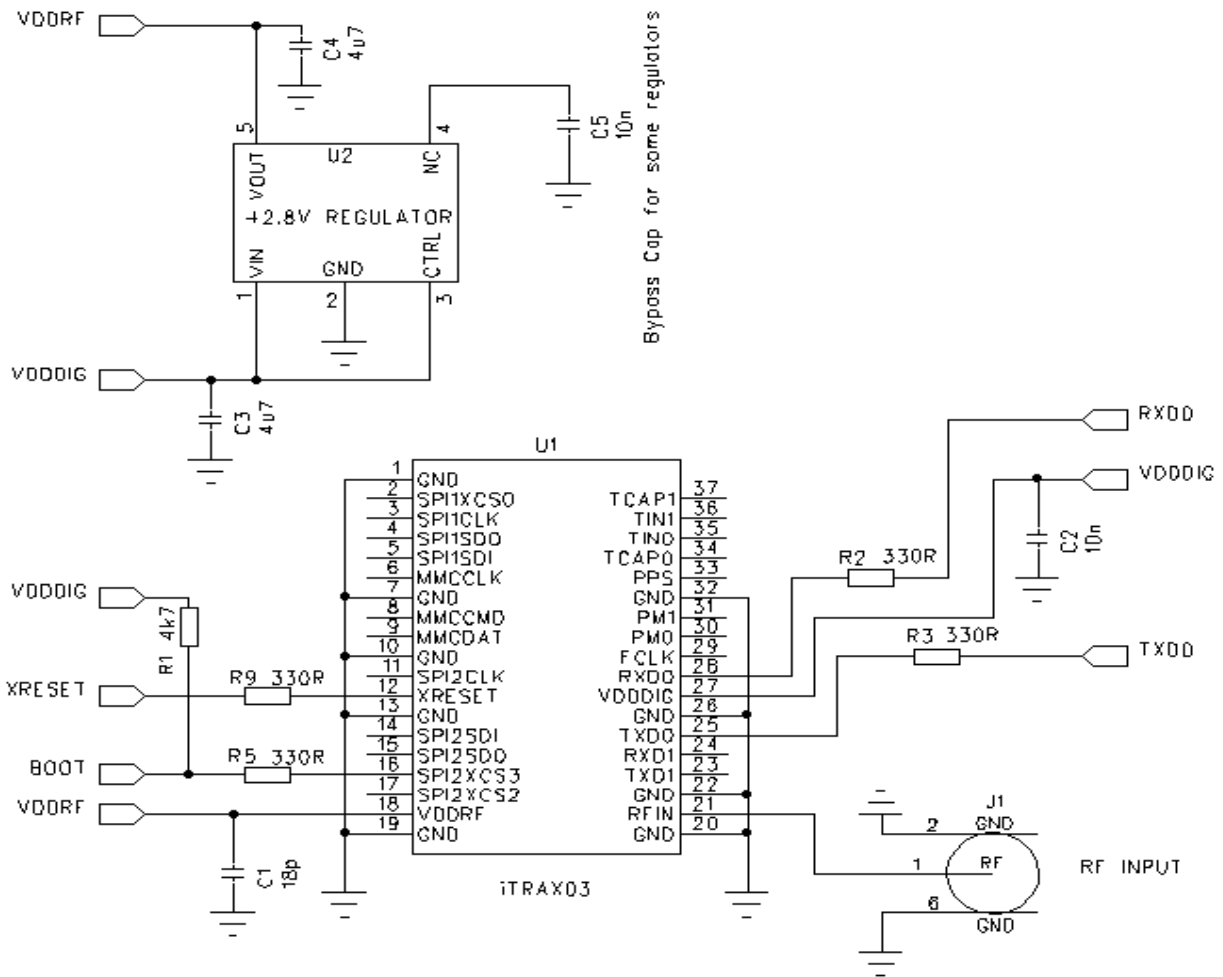

Figure 6 Minimum Application Circuit Diagram.

Note that there is a DC voltage present at the RF input, when the module is operating in Normal mode. This voltage is equal to VDDRF. If a passive antenna with a short-circuit to the GND is used, an external DC block capacitor (18pF) must be used.

5.2 Enhanced Application Circuit Diagram

A more versatile functionality can be achieved by adding the On/Off control for the Sleep mode and the secondary UART Port 1. Note that there is also a Wake-up input in pin 5 (SPI1SDI / GPIOB15). One should also support hardware re-programming of iTrax03 by adding Boot Select control (pin 16, SPI2XCS3 / GPIOB22). See Chapter 5.1 for more details.

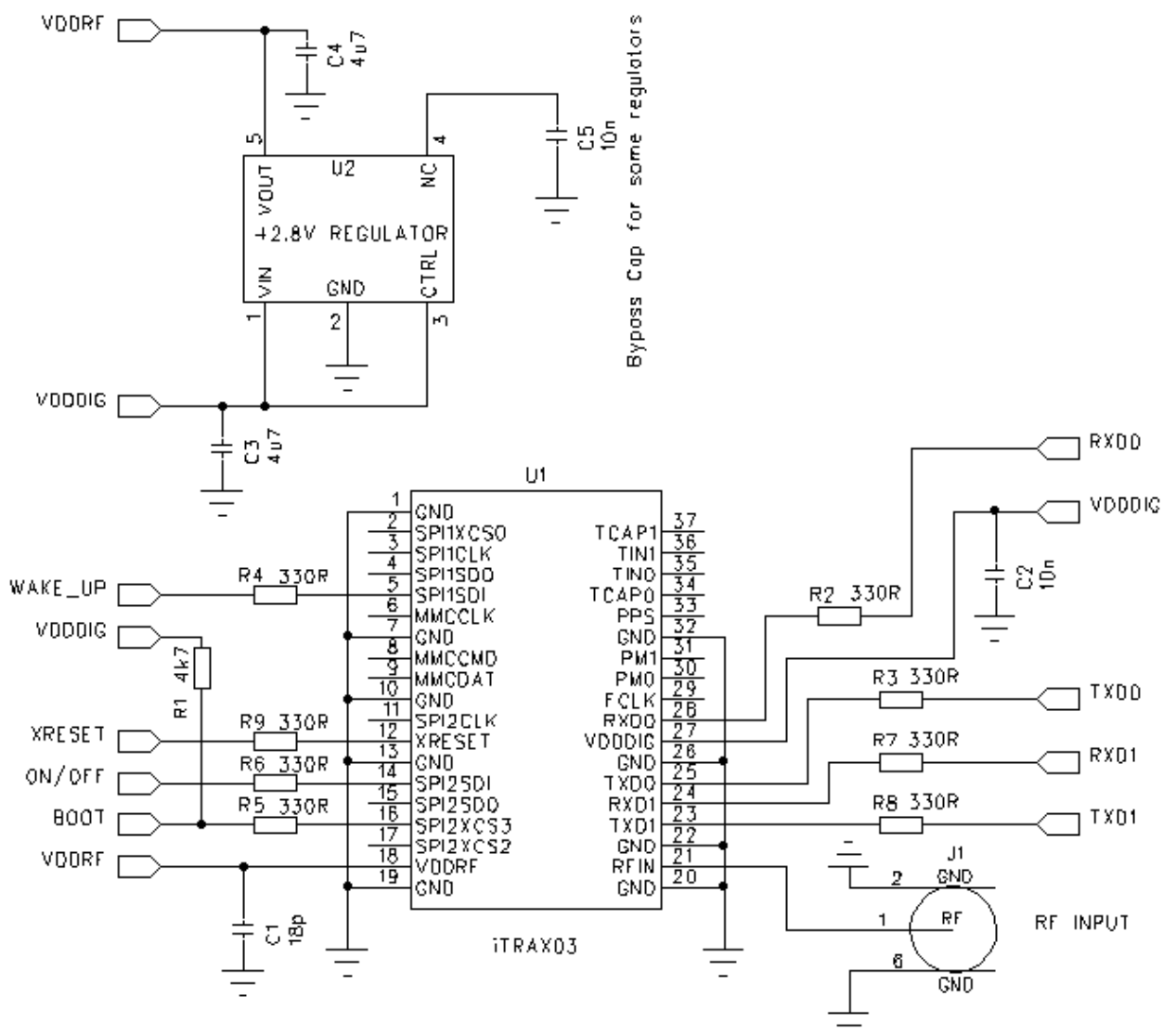

Figure 7 Enhanced Application Circuit Diagram.

5.3 PCB layout issues

The suggested 4-layer PCB build up is presented in the following table.

Table 10 Suggested PCB build up

Layer	Description
1	Signal + Ground with keep-out below iTrax03
2	Ground plane
3	Signal + Ground or VDD plane
4	Signal (short traces) + Ground

Routing signals directly under the module should be avoided. This area should be dedicated to keep-out for traces and ground (copper), except for the via holes, which can be placed close to the pad under the module. If possible, the amount of VIA holes underneath the module should be also minimized.

For a multi-layer PCB the first inner layer below the iTrax03 is suggested to be dedicated for the ground plane. Below this ground layer other layers with signal traces are allowed. It is always better to route very long signal traces in the inner layers of the PCB. In this way the trace can be easily shielded with ground areas from above and below.

The series resistors at the I/O pins should be placed very near to the iTrax03 module. In this way the risk for the local oscillator leakage is minimized. For the same reason the by-pass capacitors C1 and C2 should be connected very close to the module with short traces to I/O contacts and to the ground plane. Place the GND via hole as close to the capacitor as possible.

Connect the GND soldering pads of iTrax03 to ground plane with short traces to via holes, which are connected to the ground plane. Use preferably two VIA holes per GND pad.

The RF input should be routed clearly away from other signals. This minimizes the possibility of interference. The proper width for the 50 ohm transmission line impedance depends on the dielectric material

of the substrate and on the height between the signal trace and the first ground plane. With an FR-4 material the width of the trace is about two times the substrate height.

A board space free of any traces should be covered with copper areas (GND). In this way a solid RF ground is achieved throughout the circuit board. Several VIA holes should be used to connect the ground areas between different layers.

Additionally, it is important that the PCB build-up is symmetrical on both sides of the PCB core. This can be achieved by choosing identical copper content on each layer, and adding copper areas to routing-free areas. If the circuit board is heavily asymmetric, the board may bend during the PCB manufacturing or re-flow soldering. Bending can cause soldering failures between the iTrax03 connection pads and the application board pads.

6. ITRAX03 APPLICATION BOARD

6.1 General

The iTrax03 Application Board is intended for easy evaluation of the iTrax03 OEM GPS module and it is especially intended as a sub-system for the Evaluation Kit. It consists of the PCB board on which the surface mountable iTrax03 module is attached and two regulators, which provide two separate supply voltages +2.8V. The I/O Card Terminal connector provides all the available connectivity to the system connector of the Evaluation Kit. The MCX RF connector provides the access to the Antenna input.

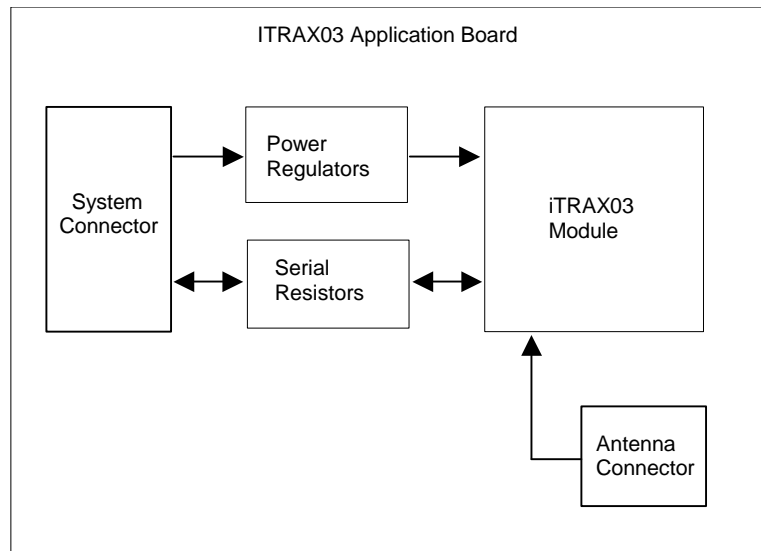

Figure 8 iTrax03 Application Board, Block Diagram.

6.2 I/O Card Terminal connector

The following signals are available at the I/O Card Terminal connector CON2.

Table 11 Card Terminal connector

Pin	Signal name	I/O	Alternative GPIO name	Signal description
1	TXD1	O	GPIOA3	UART 1 async. output
2	GND	-	-	Ground

3	RXD1	I	GPIOA2	UART 1 async. input
4	GND	-	-	Ground
5	TXD0	O	GPIOA1	UART 0 async. output
6	GND	-	-	Ground
7	RXD0	I	GPIOA0	UART 0 async. input
8	GND	-	-	Ground
9	VCC	-	-	Power input
10	GND	-	-	Ground
11	PPS	O	GPIOA7	1PPS signal output
12	GND	-	-	Ground
13	XRESET	I	-	Active low async. system reset
14	FCLK	O	GPIOA4	Pre-divided clock output of UART 1
15	SPI2XCS2	O	GPIOB21	SPI2 chip select2, (2nd boot select)
16	SPI2XCS3	I/O	GPIOB22	SPI2 chip select3, Boot Select
17	GND	-	-	Ground
18	TCAP1	I	GPIOA11	Timer TMG1 capture input
19	TIN0	I	GPIOA8	Timer TMG0 external clock input
20	TIN1	I	GPIOA10	Timer TMG1 external clock input
21	GND	-	-	Ground
22	TCAP0	I	GPIOA9	Timer TMG0 capture input
23	PM1	I	GPIOA6	Pulse measurement input 1
24	PM0	I	GPIOA5	Pulse measurement input 0
25	GND	-	-	Ground
26	MMCCMD	I/O	GPIOA13	MMC command bus, UI indicator B
27	SPI1XCS0	O	GPIOB10	SPI1 chip select 0, <i>GPIO reserved for future use. Do not connect.</i>
28	MMCCLK	O	GPIOA12	MMC clock output
29	SPI1CLK	O	GPIOB13	SPI1 clock
30	MMCDAT	I/O	GPIOA14	MMC data bus, UI indicator A
31	GND	-	-	Ground

32	SPI1SDO	O	GPIOB14	SPI1 data output
33	GND	-	-	Ground
34	SPI1SDI	I	GPIOB15	SPI1 data input, Wake-up input
35	GND	-	-	Ground
36	SPI2CLK	I/O	GPIOB16	SPI2 clock, output in master mode
37	GND	-	-	Ground
38	SPI2SDI	I	GPIOB18	SPI2 data input, On/Off control inp.
39	GND	-	-	Ground
40	SPI2SDO	O	GPIOB17	SPI2 data output, UI indicator C
Pin	Signal name	I/O	Alternative GPIO name	Signal description

6.3 Bill of Materials

Reference	Value	Qty	Manufacturer	Mfg code	Package	Part type	Description
C2	10n	1			0402	Capacitor	X7R 10%
C5-6	N/A	2			0402	Capacitor	X7R 10%
C1	18p	1			0402	Capacitor	NPO 10%
C3-4 C7-8	4u7	4	MURATA	GRM40-034X5R475K6.3	0805	CAPACITOR	X5R 6.3V
CON2		1	Samtec	EMT-120-01-S-D	SMD	Connector	SOCKET STRIP 40 PINS
J1		1	Huber Suhner	82 MCX-S50-0-22/111NE	Edge mount	Connector	MCX SMD female
U1		1	Fastrax	iTRAX03	SMD module	Module	GPS Receiver
R1	220R	1			0402	Resistor	Resistor, 5%
R2	4k7	1			0402	Resistor	Resistor, 5%
U2-3		2	MAS	MAS9161AGA2-T	TSOT 5	Regulator	LDO
REN1-6	220R	6	Philips	ARV241	0603*4	Resistor	Resistor Array

6.4 Application Board Circuit Drawing

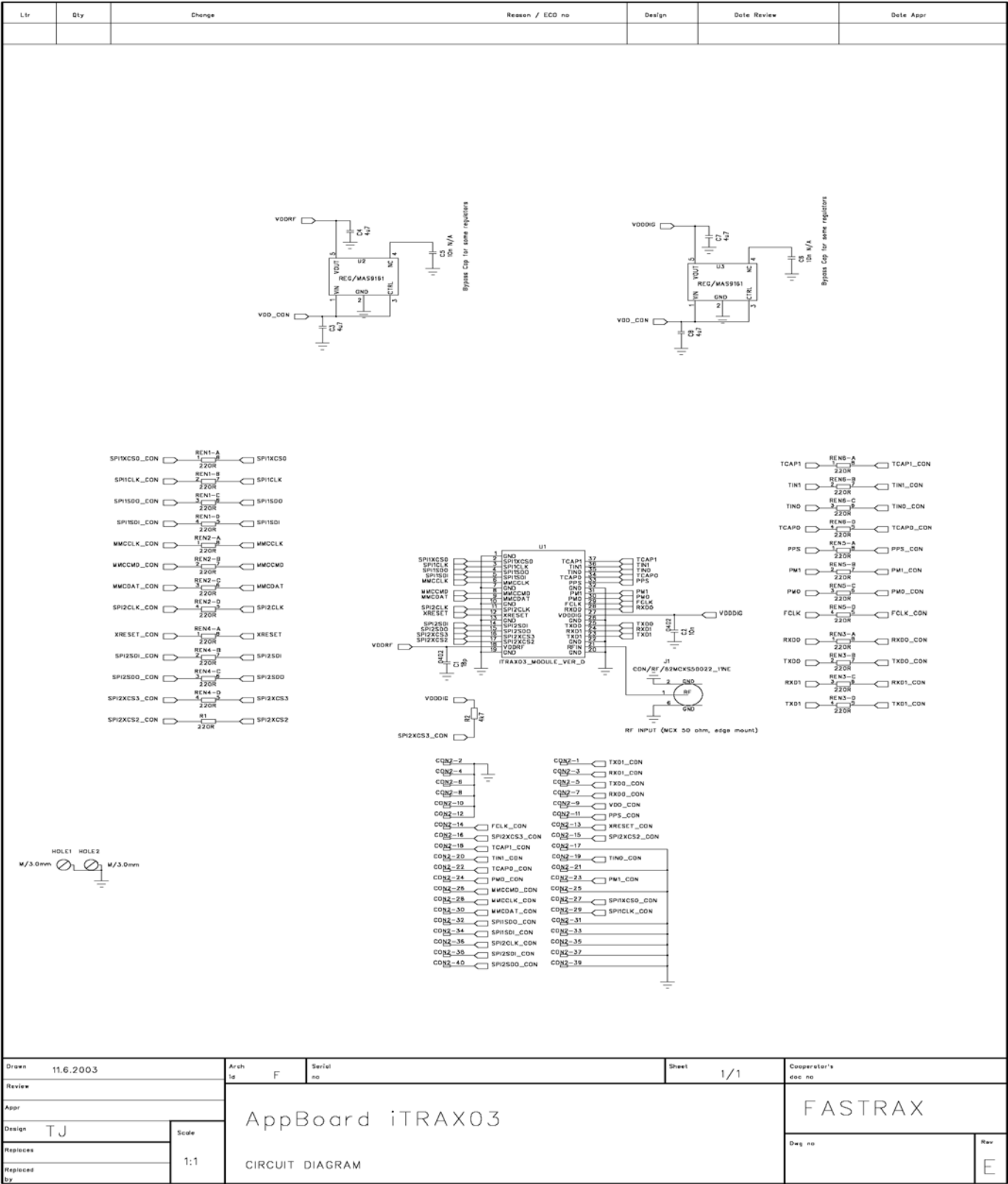

6.5 Application Board, Components layout

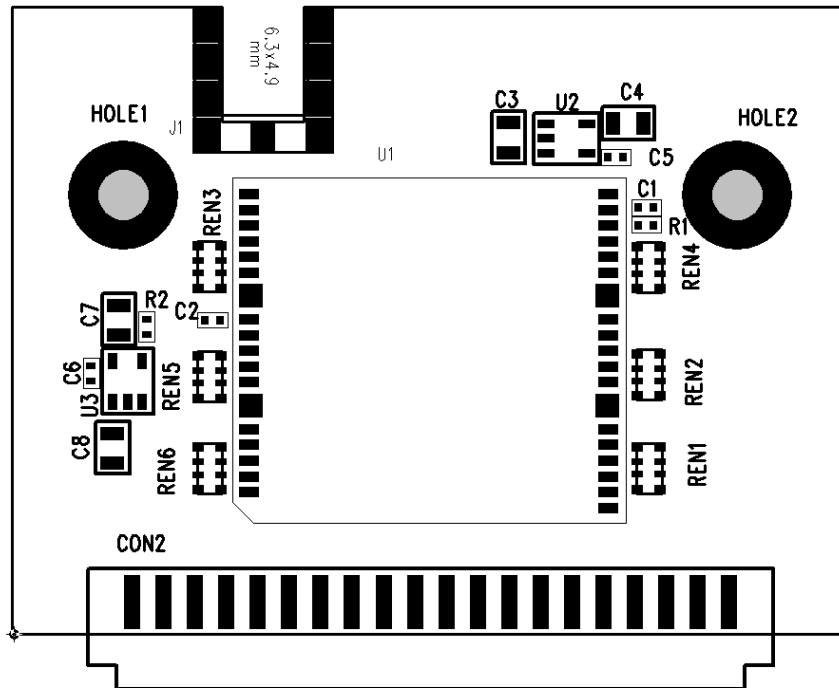

6.6 Application Board, Artwork layer 1

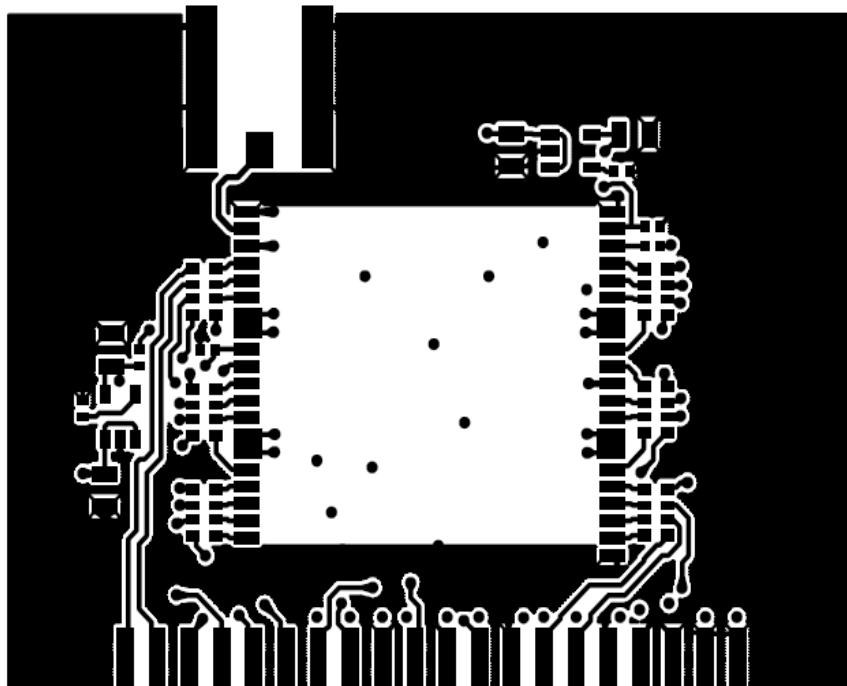

6.7 Application Board, Artwork layer 2

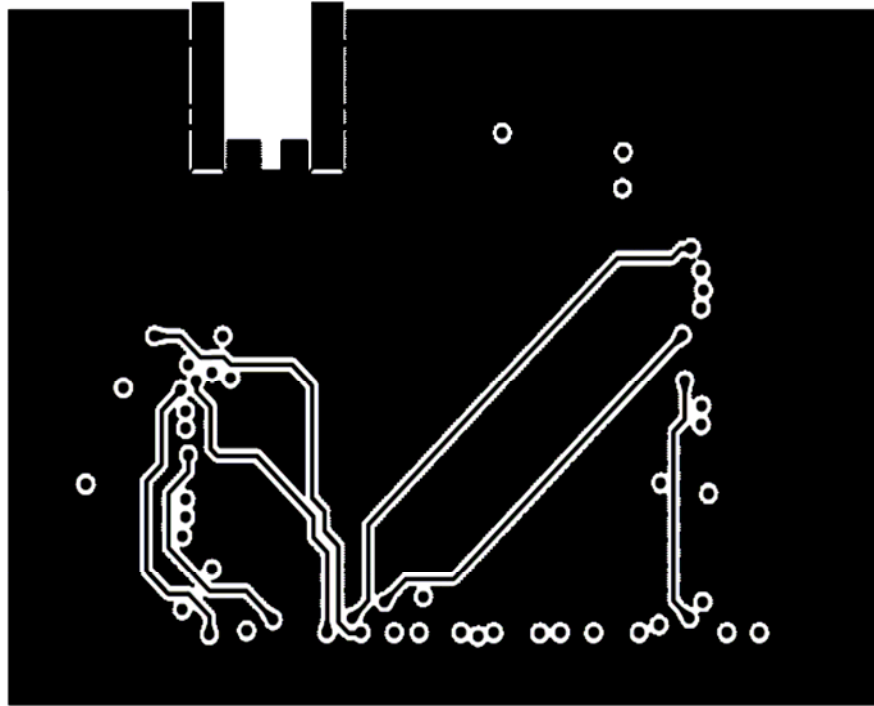

6.8 Application Board, Artwork layer 3

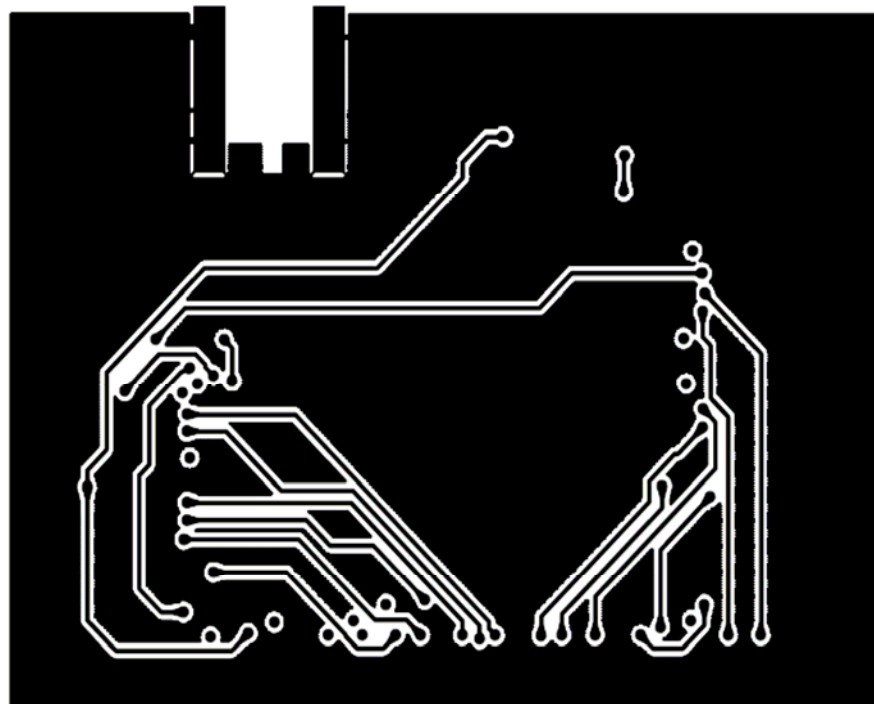

6.9 Application Board, Artwork layer 4

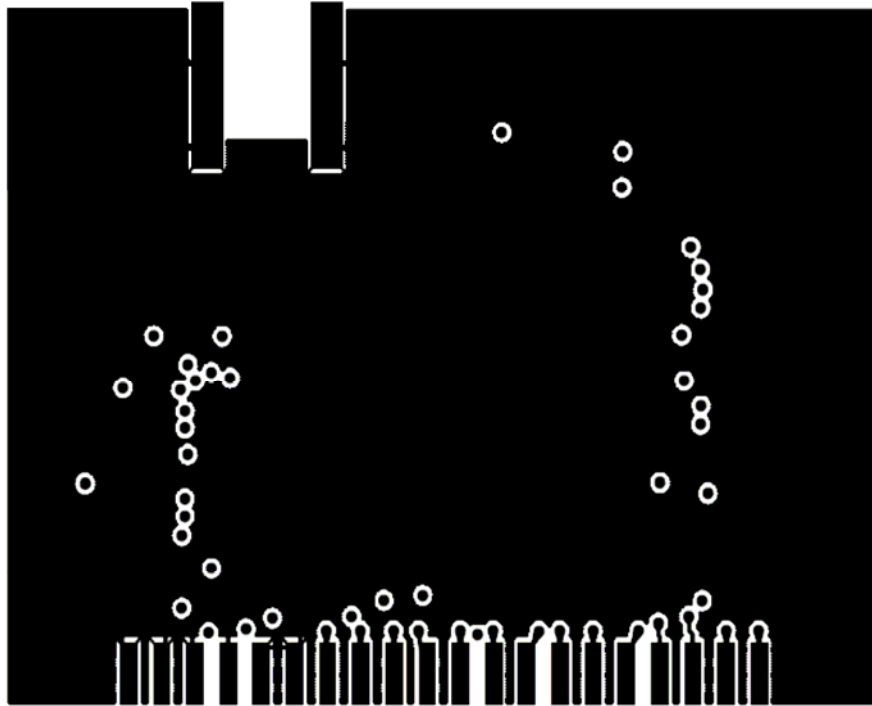

7. HANDLING INSTRUCTIONS

7.1 Moisture sensitivity and drying procedure

iTrax03 is a non-hermetic SMD device with the Moisture Sensitivity Level 3 (JEDEC standard J-STD-020B). For this reason certain handling restrictions exist. When iTrax03 is exposed from its container, moisture from atmospheric humidity starts to enter iTrax03. Assembly processes used to solder SMD packages to printed circuit boards expose the entire package body to temperatures higher than 200°C. During the re-flow soldering, rapid moisture expansion can result in component failures in the module, if there has been excess humidity in iTrax03. This is why the following instructions must be followed.

The instructions for handling iTrax03 before the re-flow soldering process:

1. The time period between the opening of the iTrax03 Moisture Barrier Bag and the re-flow soldering process should be minimized. The maximum time period (called Floor Life) is 168 hours (1 week) for iTrax03. If this period is not exceeded, the drying process according to the item 3 is not necessary.

2. If the Moisture Barrier Bag has to be opened far earlier than the date of the reflow soldering, it is a good practice to store the iTrax03 modules into a Dry Cabinet. In this way the Floor Life clock is not running. Note that the tape & reel itself is not an adequate screen against the atmospheric moisture.

3. If the time between the opening of the Moisture Barrier Bag and the re-flow soldering is more than one week and the Floor Life (168 hours = 1 week) is thus exceeded, the iTrax03 module must go through a drying process. The drying process consists of keeping iTrax03 at +90C for 33 hours. During the drying process (called Baking) the relative humidity must be smaller than 5%.

iTrax03 must be removed from the tape before drying. Otherwise the drying process may fail to perform successfully.

4. Observe the color dots in the Humidity Indicator, which can be found inside the iTrax03 Moisture Barrier Bag. If the 10% color dot or the 15% color dot is pink, the modules must be dried according to the item 3.

5. The factory ambient should not exceed 30°C and 60% relative humidity during the time which iTrax03 is out from the Moisture Barrier Bag and not yet re-flow soldered.

8. PRODUCT LINE-UP

8.1 iTrax03/8 with 8 Mbit Flash memory

The iTrax03/8 is provided with an internal 8 Mbit Flash memory. It supports basic functionality and permanent configuration storage to the Flash.

8.2 iTrax03/16 with 16 Mbit Flash memory

The iTrax03/16 is provided with an internal 16 Mbit Flash memory. It supports basic functionality and permanent configuration storage to the Flash, extensive data Logging system and support for firmware customization with the SDK.