

Technical Data

Part Number	RB350018-2A723R		
Customer P/N			
ITEM	Specifications	Note	
1. Operation Status			
1.1 Rated Voltage	12V D.C.	Stable power source 10mm from shaft end	
1.2 Rated torque	1.0 kgf.cm		
1.3 Radial load	1 kgf		
1.4 Axial load	0.7 kgf		
1.5 Turning direction	Shaft horizontal		
1.6 Reverse direction	CW.CCW		
1.7 Using environment	Temperature -10~60 °C Humidity 20~85% RH		
1.8 Preserve environment	Temperature -10~60 °C Humidity 20~85% RH		
1.9 Using voltage range	12V (D.C.) ±10%		
2. Electrical Characteristics			
2.1 No Load current	290 mA max.		
2.2 No Load speed	333 rpm ±10%		
2.3 Rated current	0.72 A		
2.4 Rated speed	317 rpm ±10%		
2.5 Stall current	9.4 A		
2.6 Stall torque	21 kgf.cm		
2.7 Insulation	D.C. 500V meg. 10 MΩ min		Motor terminal shell
2.8 Durable voltage	100V (A.C.) , 1 minute min		Motor terminal shell
2.9 Coil resistance	1.27Ω		Reference
2.10 Torque constant	2.23 kgf.cm/A	Reference	
2.11 Voltage constant	21.29 mV/r/min	Reference	
3. Mechanical characteristic			
3.1 Reduction ratio	1/18		
3.2 Thrust play of shaft	0.35 mm max.		
3.3 Radial play of shaft	0.05 mm max.		
3.4 Back lash	2° max.		
3.5 Outside Appearance	No scratch defective....	By visual judgment	
2. Life Cycle	108000 cycles min.		
	<p style="text-align: center;"> ccw 5 5 5 5 off [] [] [] [] off [] [] [] [] cw ← 1 cycle → </p>	After the rated life cycle test current @ rated load must stay within ±30% of the initial value and r.p.m. @ rated load must stay within ±20% of the initial value. However change of mechanical noise level was not considered as part of the testing	

ASSEMBLY, MAINTENANCE, OPERATION

1. Install: To avoid internal geared motor touched by overlong screws and caused defective. Please check screw size and length on external dimension drawing when installing geared motor into construction.

2. Reprocess: Heavy impact and vibration during reprocessing output shaft may cause loose screws and lead to unbalance gear operation. Please avoid reprocessing output shaft. Must to prevent overheat when weld wires into terminal and cause breakdown due to burnt internal geared motor parts.
Please do not overload the radial load limitation of output shaft when using belt pulley or chain pulley as power transmission. Please do not overload the axial load limitation of output shaft when pressing parts upon it as well.

3. Environment: The parts of geared motors or itself may corroded or damaged easier when using or maintaining in out of range environment. Must to pay close attention that gears may corroded even under an allowed environment in long term.

4. Impact: Must prevent geared motor from falling and impact, or the parts will get damaged, the screws will be loosed, and the gear operation will unbalance etc...

5. Locked out: Please well prepared current transmitting protection in case of burnt motor coil easy and damaged gear from locked out geared motor.

6. Output shaft Turning:
Please note that it is easier to damage gear when directly turning output shaft.

7. PWM controlling:
The graphite brush of motor will be abnormally wore out or the commutator interval will be blocked by carbon powder when using in the condition of D/T under 60%.
Moreover, please pay attention to the motor with capacitor due to there is ineffectual capacity cycle scope.

8. Momentary reverse:
The graphite brush will be abnormally wore out or coil getting aggravated when geared motor is reversed momentary.
Also, the commutator interval will be stuck if switch frequently.

SHAYANG YE INDUSTRIAL CO.,LTD.

Mode: RB350018-2A723R

S/N: 001

Voltage : 12 V

Date: 20141030

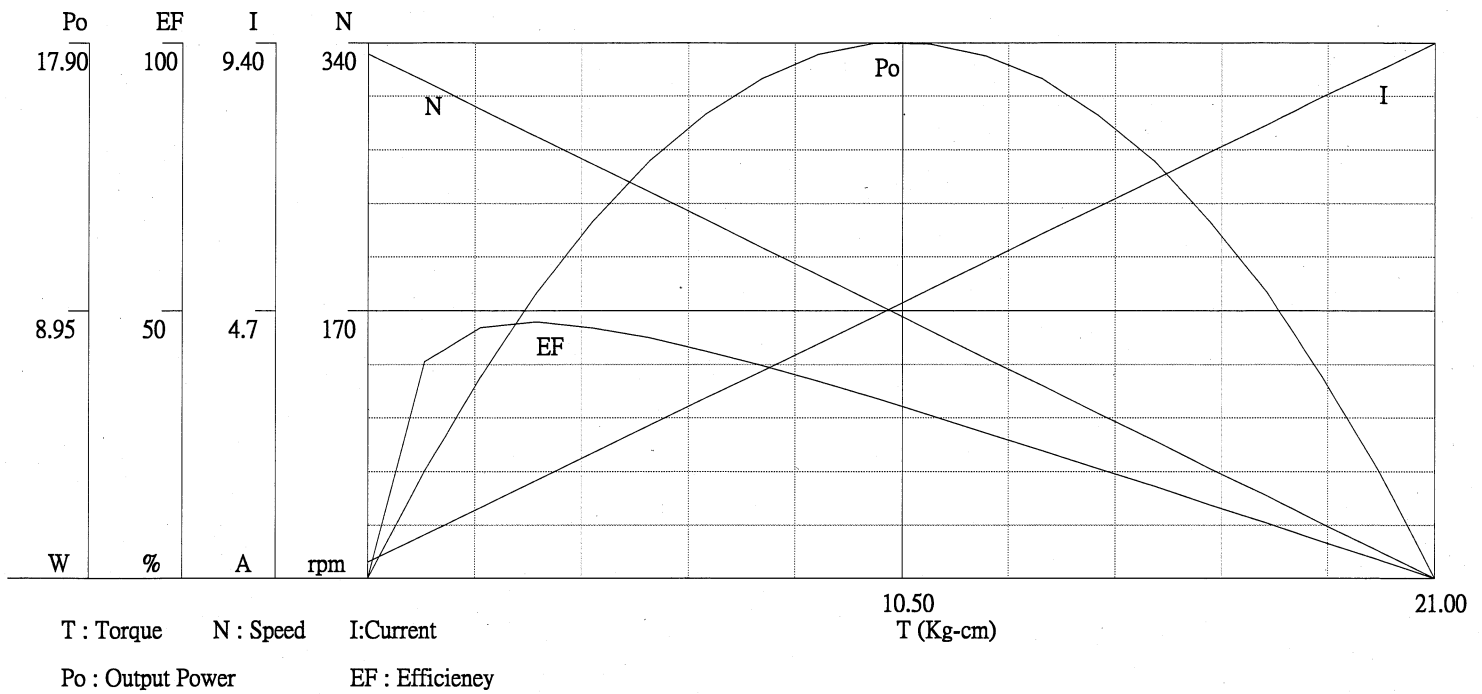

	T(N/m)	[Kg/cm]	N(rpm)	I(A)	Po(W)	EF(%)
No Load	0	0.00	333.00	.29	0	0
	.11	1.11	315.58	.77	3.6	40.53
	.43	4.42	263.04	2.21	11.93	46.83
	.54	5.53	245.57	2.69	13.94	45.02
	.65	6.63	227.89	3.17	15.51	42.47
	.76	7.74	210.31	3.64	16.71	39.88
	.87	8.85	192.88	4.12	17.52	36.94
	1.08	11.04	157.59	5.08	17.86	30.54
	1.19	12.15	140.11	5.56	17.47	27.28
	1.3	13.26	122.79	6.05	16.71	23.98
	1.41	14.36	105.06	6.52	15.48	20.62
	1.52	15.48	87.68	7.00	13.93	17.29
	1.62	16.57	70.14	7.48	11.93	13.85
	1.74	17.70	52.62	7.96	9.56	10.42
	1.95	19.90	17.52	8.92	3.58	3.48
Stall	2.06	21.00	0.00	9.40	0	0
Po...(max)	.98	9.96	175.12	4.60	17.9	33.78
EF...(max)	.33	3.32	280.36	1.73	9.55	47.98

參考 REF.
估價 EVALUATE
試作 INITIAL
製作 MASS

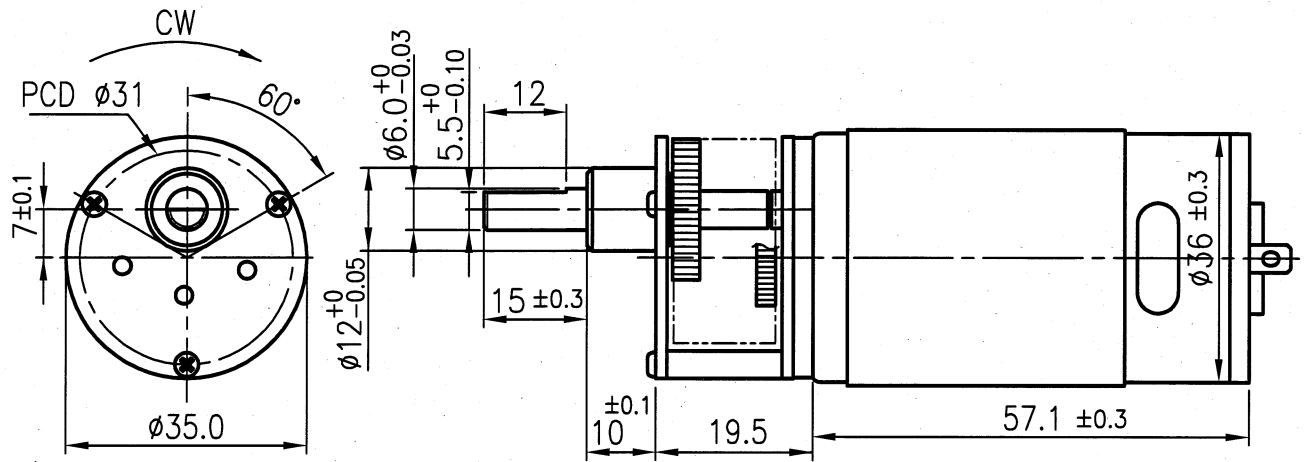

REDUCTION RATIO: 1/18
 OUTPUT SHAFT: STEEL
 MOTOR SPECIFICATION: 12V 6000RPM

核准
APPROVED BY



核對
CHECKED BY

一般公差表	軸徑 $\begin{smallmatrix} 0 \\ - \end{smallmatrix}$ 孔徑 $\begin{smallmatrix} + \\ 0 \end{smallmatrix}$ 長度, 角度 \pm -	1	新出圖						
	- 指定等級區分之數值公差								
	區分	1~6	6~18	18~50	50~120	120~250	250~500	500~1000	角度
	等級	1級	0.1	0.2	0.3	0.4	0.5	0.6	0.8
	2級	0.2	0.4	0.6	0.8	1.2	1.6	2.0	2°
	未標示孔徑距公差	±0.1			±0.2				
		設變單號 E.C.N.				設變單號 E.C.N.			
熱處理 HEAT TREATMENT		件名 PART NAME	GEARMOTOR			單位 UNITS	mm		
表面處理 SURFACE		圖號 DWG.	RB350018-2A723R			比例 SCALE	9/10		
材質 MATERIAL									
重量 WEIGHT		頁次 SHEET	1/1						