

**Description**

The SL5018/P is designed for use in FM dual conversion communication.

It contains a complete narrow band FM demodulation system operable to less than 2.0V supply voltage. This low power narrow band FM IF system provides the second converter, second IF, demodulator. Filter Amp and squelch circuitry for communications and scanning receivers.

**Features**

- Operating voltage range : 2.0V ~ 8.0V
- Low Current consumption  $I_{CC}=4.0\text{mA}$  Typ. ( $V_{CC}=4.0\text{V}$ )
- Excellent input sensitivity (-3dB Limiting =  $2.0 \mu\text{V}_{\text{rms}}$  Typ.)
- Low number of external parts required
- Operating frequency up to 60MHz

**Ordering Information**

Type NO.	Marking	Package Code
SL5018	SL5018	SOP16
SL5018P	SL5018	DIP16

**Outline Dmensions**

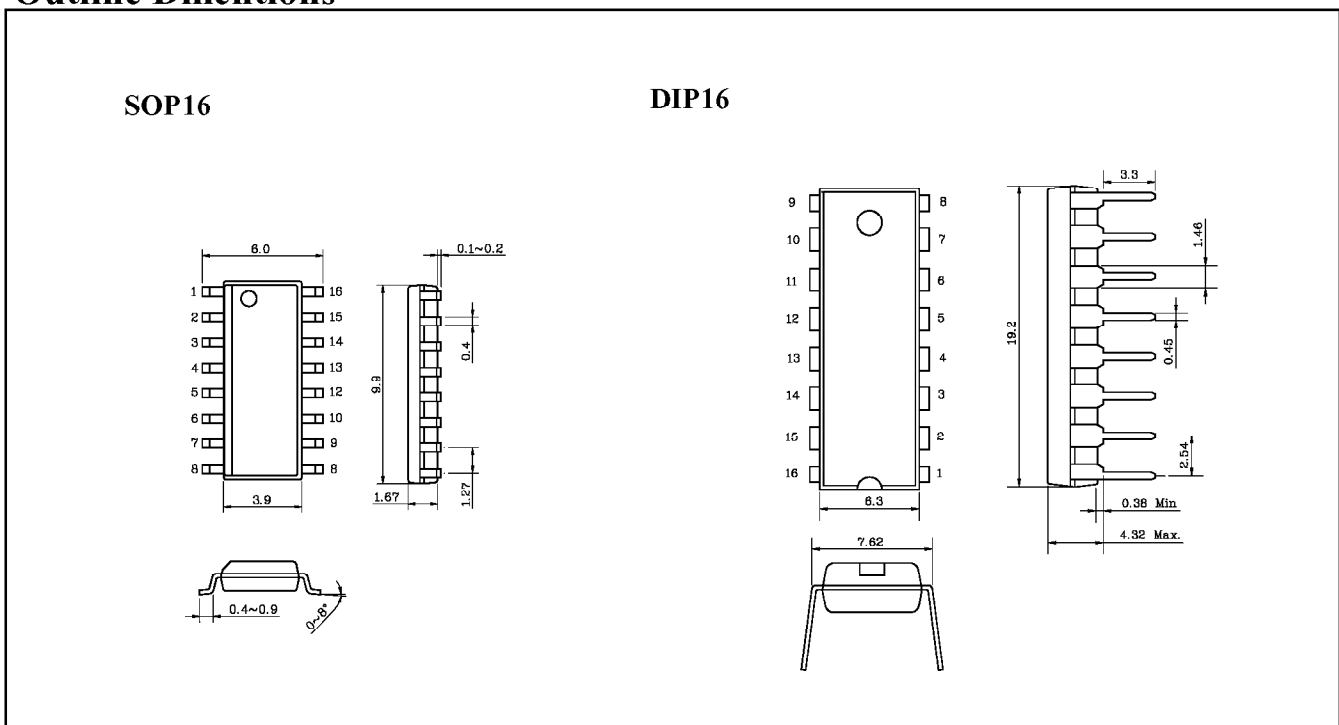

## Absolute Maximum Ratings

(Ta=25 °C)

Characteristics	Symbol	Rating	Unit
Maximum Supply Voltage	$V_{CC(MAX)}$	10	V
Supply Voltage Range	$V_{CC}$	2.0 ~ 8.0	V
Detector input Voltage	$V_{IN(DET)}$	1.0	$V_{p-p}$
RF Input Voltage( $V_{CC} \geq 4.0V$ )	$V_{IN(RF)}$	1.0	$V_{rms}$
Mute Function	$V_{MUTE}$	-0.5 ~ +5.0	$V_{peak}$
Operating Temperature	$T_{opr}$	-20 ~ +70	°C
Storage Temperature	$T_{stg}$	-65 ~ +150	°C

## Electrical Characteristics

(Unless otherwise specified Ta=25 °C , Vcc=4V, fo=10.7MHz, fm=1kHz, Δf = + 3kHz)

Characteristics	Symbol	Test Condition	Min.	Typ.	Max.	Unit
Squelch Current (No signal)	$I_{CC1}$	Squelch off( $V_{12} = 2V$ )	2.9	3.9	4.9	mA
	$I_{CC2}$	Squelch on( $V_{12} = 0V$ )	4.4	5.4	6.4	
Audio output Voltage	$V_{OUT}$	$V_{in} = 10mV_{rms}$	130	160	200	$mV_{rms}$
Input Limiting Voltage	$V_{IN(Lim)}$	-3dB Limiting	-	2.0	6.0	$\mu V$
Total Harmonic Distortion	THD	$V_{OUT} = 170mV_{rms}$	-	0.8	-	%
Recovered output Noise Voltage	$V_{NO}$	No Input Signal	60	80	250	$mV_{rms}$
Drop Voltage AF Gain Loss	$\Delta G_V$	$V_{CC} = 4V \rightarrow 2V$	-3	-0.6	-	dB
Detector Output Resistance	$R_{OUT}$	-	-	450	-	$\Omega$
Signal to Noise Ratio	S/N	-	36	67	-	dB
Filter Gain	$G_V$	$f = 10kHz, V_{in} = 5mV_{rms}$	40	50	-	dB
Filter Output DC voltage	$V_{O(DC)}$	-	1.0	1.3	1.6	$V_{DC}$
Mute Low Resistance	$R_{ON(Mute)}$	Mute Switch-on	-	10	-	$\Omega$
Mute High Resistance	$R_{off(Mute)}$	Mute Switch-off	1.0	10	-	$M\Omega$
Scan control Low	$V_{L(Scan)}$	Mute off( $V_{12} = 2V$ )	-	0	0.4	$V_{DC}$
Scan control High	$V_{H(Scan)}$	Mute on( $V_{12} = 0V$ )	3.0	3.5	-	$V_{DC}$
Trigger Hysteresis	$V_{TH}$	Squelch on/off	-	45	100	$mV_{rms}$
Mixer conversion Gain	$G_V(Mix)$	-	-	28	-	dB
Mixer Input Resistance	$R_{i(Mix)}$	-	-	3.3	-	$k\Omega$
Mixer Input Capacitance	$C_{i(Mix)}$	-	-	2.2	-	pF

**PIN Configuration**

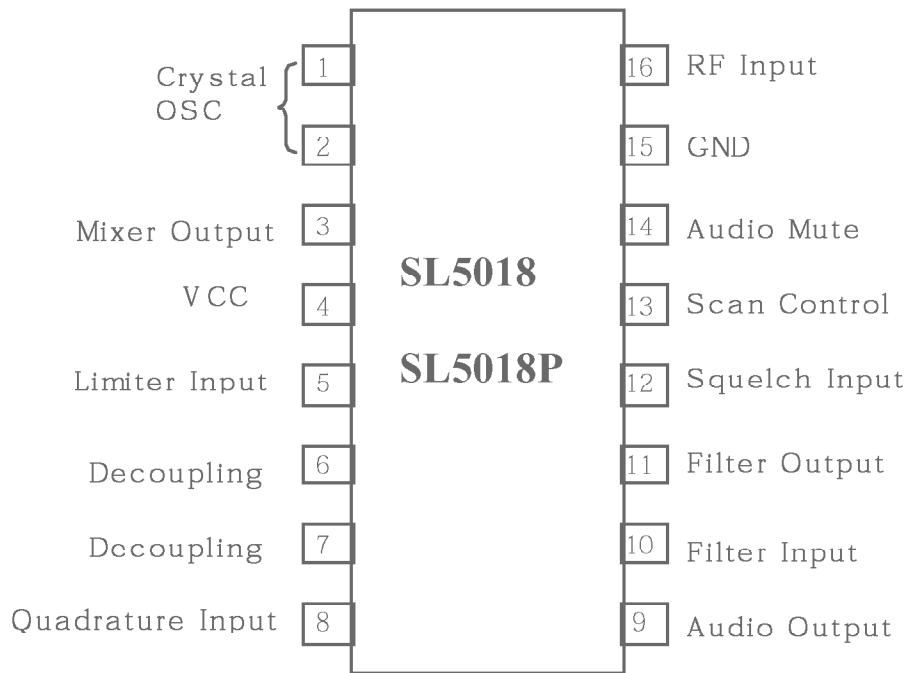

**Block Diagram and Test Circuit**

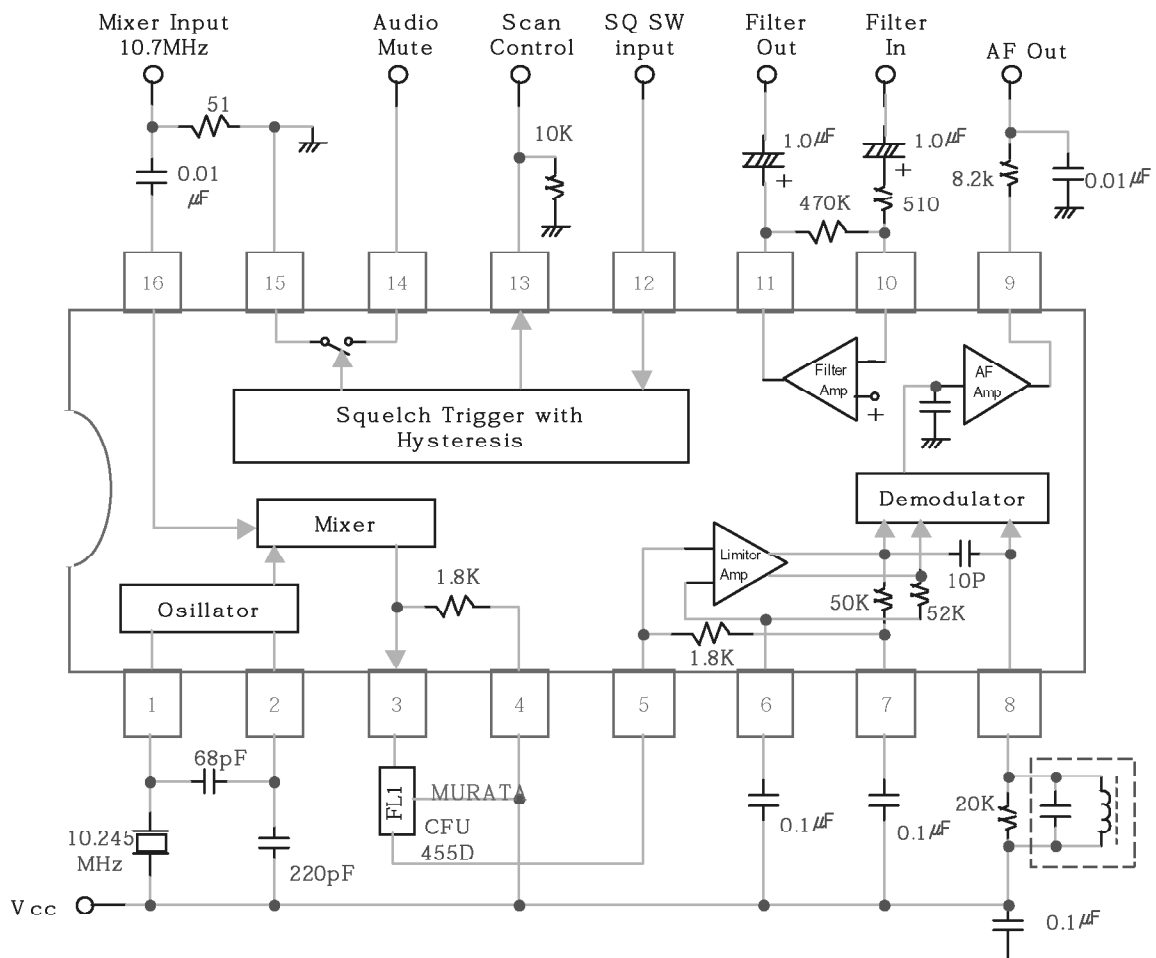

Application Circuit

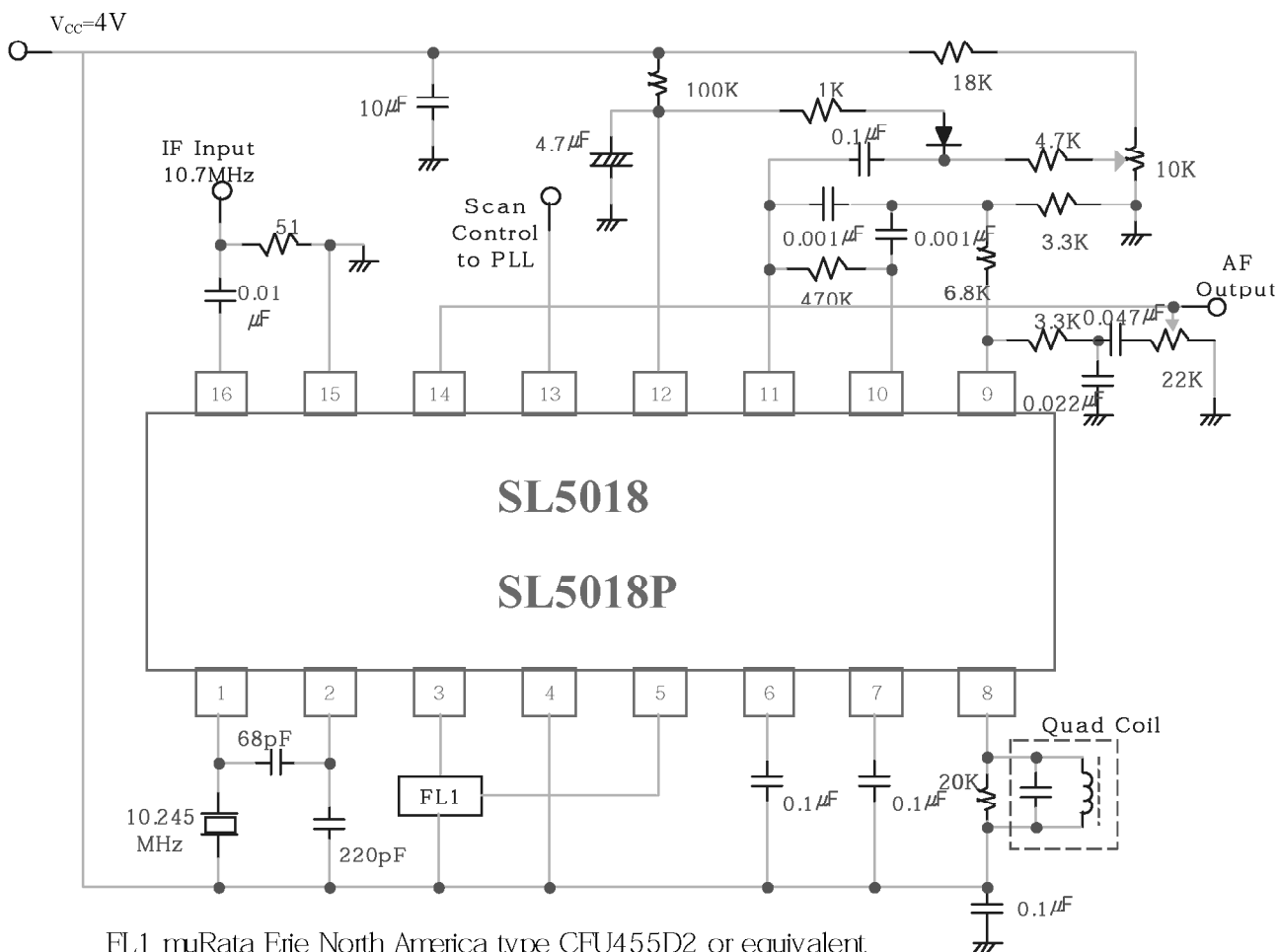

FL1 muRata Erie North America type CFU455D2 or equivalent  
 Quadrature Coil Toko America type 7MC 8128Z or equivalent

Typical Performance Characteristics

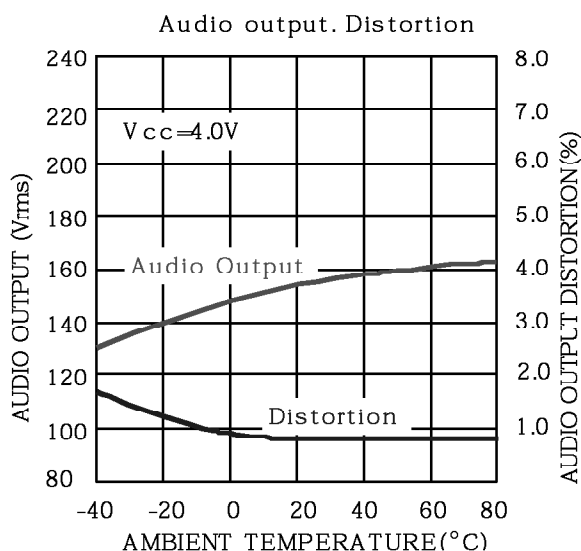
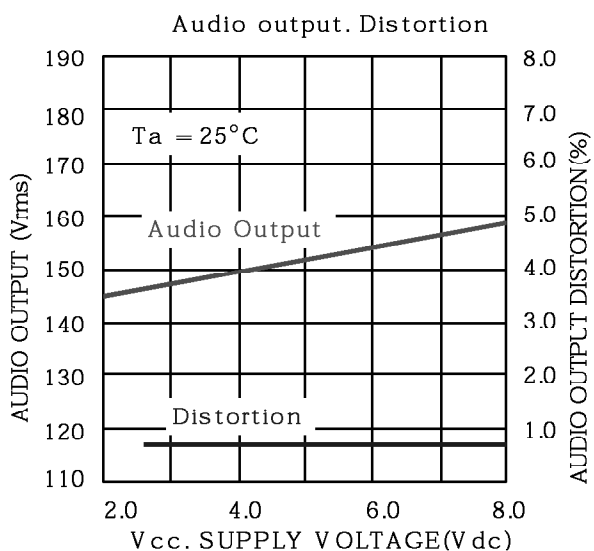

Typical Performance Characteristics (continued)

