



HAKKO 707

DESOLDERING TOOL

INSTRUCTION MANUAL

Please read this instruction manual thoroughly before operating the HAKKO 707

Developed from years of soldering experience, the **HAKKO 707** is a newly designed desoldering tool featuring the latest advances in soldering technology. This instruction manual describes the correct methods of operation, inspection and repair.

Table of Contents

	Page
1. Specifications	1
2. Part Name	3
3. Setting Up the No.707	5
4. Cautions	5
5. Operating Procedures	6
6. Maintenance	8
7. Troubleshooting Guide	14
8. Wiring Diagram	15
9. Replacement Parts	15

The specifications written here may be subject to change without notice.

1. Specifications

Electrical Rating

Power Supply AC110—120V, 220—230V, 240V.
Power Consumption 100W

a) Desoldering Station (Vacuum Pump)

Pump Type Diaphragm Type
Vacuum Pressure 600mm Hg (11 lb/in²) max.
Motor Power 25W(4-pole)
Fuse 2A
Outer Dimensions 160mm(6.3in)(W) × 140mm
(5.52in)(H) × 250mm(9.84in)(D)
Weight Approx. 3.4kg(7.48 lb)

b) Desoldering Iron

Heating Element 60W (Ceramic)
Temp. Control 400° C(752° F)—500° C(932° F)
continuously variable.
Filter Pipe Pyrex (heat resist glass)
Filter 2 stage (easy replaceable)
Cord/Hose 1.5 meters (59.06in), each
Pump Connection Large metal connector plug
(with grounding pin)
Nozzle (inner dia.) Standard 1.0mm(0.039in),
0.8mm(0.031in), 1.3mm(0.051in)
& 1.6mm(0.063in) are optional.
Weight Approx. 210g(0.46 lb) w/o
cord & hose.

c) Accessories

Special Iron Stand	1 pc	
Nozzle Cleaning Pin (small)	1 pc	
Heating Core Cleaning Pin (large)	1 pc	
Filter Set (Steel Wool Filter & White Felt Filter)	5 sets	
Anti-seizing Lubricant	1 pc	
Nozzle Cleaning Wrench	1 pc	
Vacuum Outlet Cap	1 pc	
Check Valve	1 pc	

2. Part Name

A) Vacuum Pump

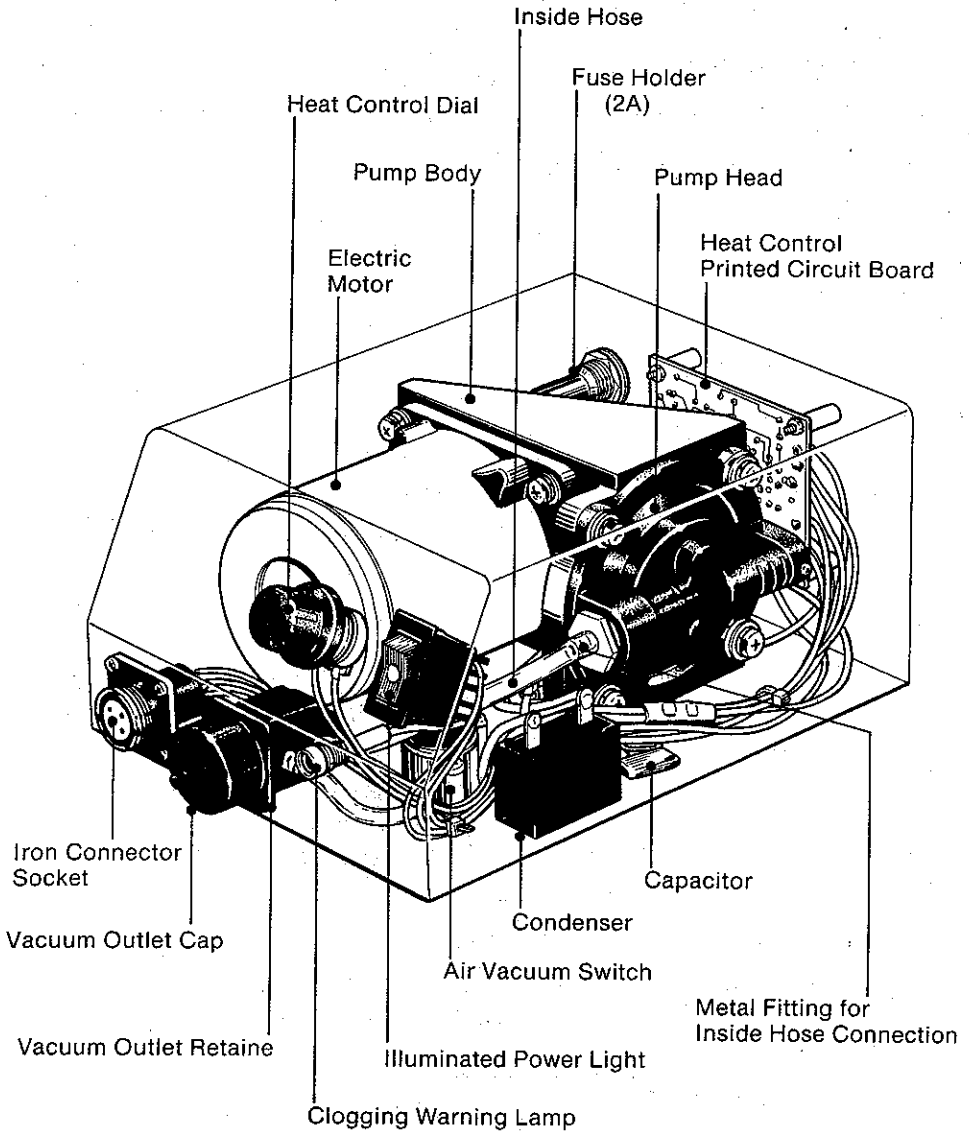

(Fig.1)

B) Desoldering Iron

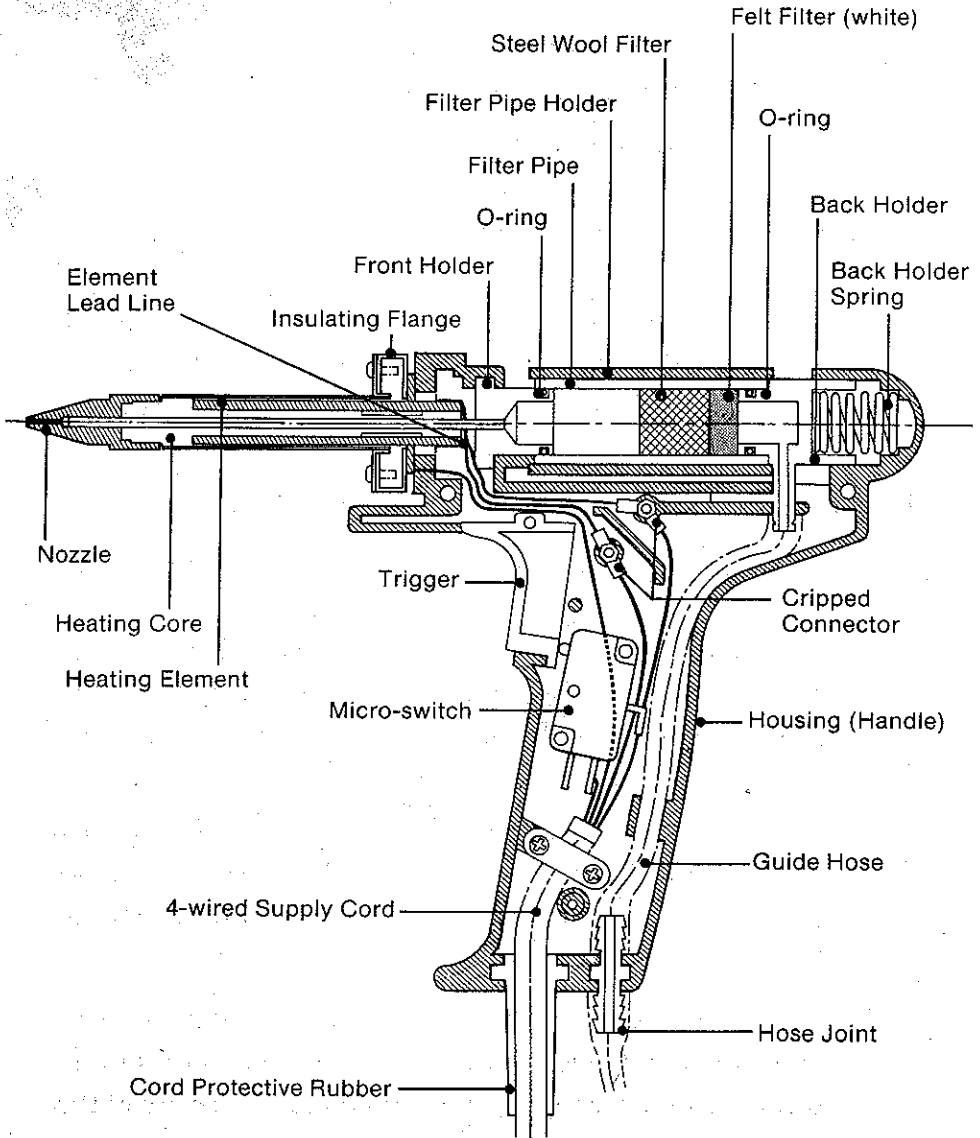

(Fig.2)

3. Setting Up the No.707

1. Remove the packing cover from the vacuum outlet retainer. Screw the vacuum outlet cap with the white felt filter onto the vacuum outlet.
2. Assemble the iron stand as shown in Fig.3. (This iron stand is to be attached on either side of the housing.)

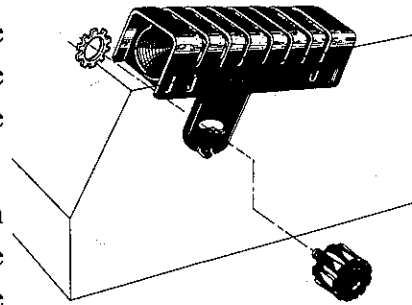

(Fig.3)

3. The new nozzle, prior to its first use, will have been closed by pre-tinning. It will open by itself when the iron is heated and the vacuum pump activated for the first time.

4. Cautions

1. After turning on the power, wait for 10 minutes before using the unit.
Do not use the iron before it has heated sufficiently, as use before this time may result in the nozzle hole or the heating element becoming clogged with cold solder and flux.
2. Clean the nozzle and the heating core with the provided pins after every use, and loosen the nozzle between uses to prevent the clogging or “freezing” of the nozzle and the heating element.
3. Set the heat control dial at “1” when the unit is to be used for an extended period. This will prevent the nozzle from becoming clogged, and extend the service life of the unit.

5. Operating Procedures

1. First, connect the desoldering iron connector plug to the iron connector socket, and the suction hose to the vacuum outlet. Then, place the desoldering iron in the iron stand, and adjust the angle of the stand.
2. Plug the power cord into the power supply.
3. Adjust nozzle temperature with the heat control dial.

Standard Temperature Control Settings	
Single-Layer P.C.B.	400° C
Through-Hole P.C.B.	400° C — 450° C
Multi-Layer P.C.B.	450° C — 500° C

Setting "1" —

Approx. 400° C (752° F)

Setting "6" —

Approx. 450° C (842° F)

Setting "11" —

Approx. 500° C (932° F)

4. Turn the power switch on, checking that the power switch indicator light is on, and allow the unit to preheat for about 10 minutes before use.
5. After the unit has been allowed to preheat, clean the nozzle with the provided nozzle-cleaning pin (small pin). Then, remove the nozzle from the soldering iron and clean the heating core with the provided heating core cleaning pin (large pin) and reattach the nozzle.
6. Place the nozzle on the lead of the component to be removed, and move the iron back and forth gently for 2 or 3 seconds. When the lead begins to move freely, the solder sufficiently melted. Pull the desoldering iron trigger, and the vacuum pump will draw off the melted solder.

Note: If the solder has not been sufficiently melted, the component will not be properly desoldered. Should this occur, resolder the component and repeat the desoldering process.

7. If there is any reduction in suction, the clogging indicator will light up. If this occurs, the nozzle, heating element, filters, and so forth should be checked.
8. When desoldering has been completed, clean the nozzle and the heating element according to the procedure outlined in step 5 above. Then, loosen the nozzle and turn the power switch off.
9. If air begins to leak from the nozzle, the provided check valve should be attached as follows:
 - Remove the suction hose from the vacuum outlet. Then, remove the vacuum outlet and the filter retainer from the vacuum outlet retainer.
 - Attach the check valve as shown in Fig. 4, and reassemble the unit, reversing the steps above.

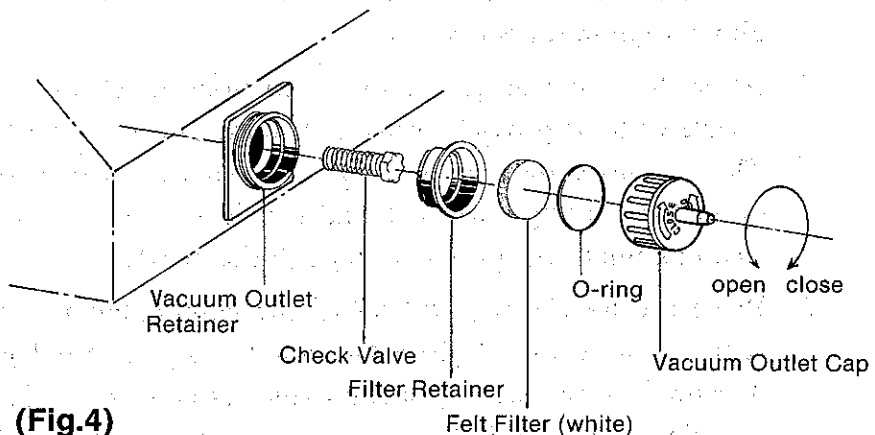

(Fig.4)

Note: After prolonged use with the check valve in place, adhered flux, etc. may cause reduction in the unit's suction. If this occurs, remove and check the valve, cleaning it with alcohol or some other suitable solvent when necessary.

6. Maintenance

A) Replacement of the Filters

a. Should the suction power of the desoldering iron become reduced due to the accumulated solder in the filter pipe, replace the steel wool and felt filters in the following manner.

1. Pull the pipe holder backward, then raise the front of the holder and release it.

Caution: 1. If the filter pipe is hot, turn the power switch off and wait until the pipe has cooled, or wear a glove while handling it.

2. Do not drop the filter pipe. It is made of Pyrex glass and is very fragile.

2. Remove the accumulated solder from the filter pipe. If necessary, replace the steel wool and felt filters. The felt filter should be replaced whenever it has become colored or hardened with flux.

Caution: Never attempt to use the desoldering iron without the filters in place as the vacuum pump may be damaged.

Note: Be sure to insert the filters so that the felt filter is at the back and the steel wool filter is at the front of it.

b. Should the suction power remain weak after replacing the filters, the felt filter in the vacuum outlet retainer must be replaced. This should be done as follows. (See Fig.4)

1. Turn the vacuum outlet cap to the left and remove it.

2. Replace the white felt filter that is inside the vacuum outlet retainer.

Note: The felt filter in the vacuum outlet retainer is the same as the one used in the filter pipe.

B) Replacement of the Nozzle

1. Use a nozzle cleaning wrench to unscrew (counterclockwise) the nozzle.
2. Coat the threads of the new nozzle with the supplied anti-seizing lubricant and screw the nozzle onto the desoldering iron. Once a week coat the threads of the nozzle as above.

Note:

1. The nozzle should be replaced while the desoldering iron is hot as solder may be binding the nozzle to the heating core.
2. Be careful not to overtighten the new nozzle as you may strip the threads.
3. At the end of each day of use, loosen the nozzle to prevent it from "freezing" (seizing).

C) Replacement of the Heating Element

Should the heating element break, replace it in the following manner.

1. Remove the filter pipe by referring to the filter replacement procedure (A)-(a).
2. Remove the 4 flange set screws.
3. Remove the 3 housing set screws, and carefully lift off the housing.
4. Unscrew the heating element connection nuts.

5. Remove the heating core from the front holder.
6. Replace it with a new one.
7. Reassemble the desoldering iron by following the disassembling steps in reverse order.

Desoldering Iron Construction Sketch.

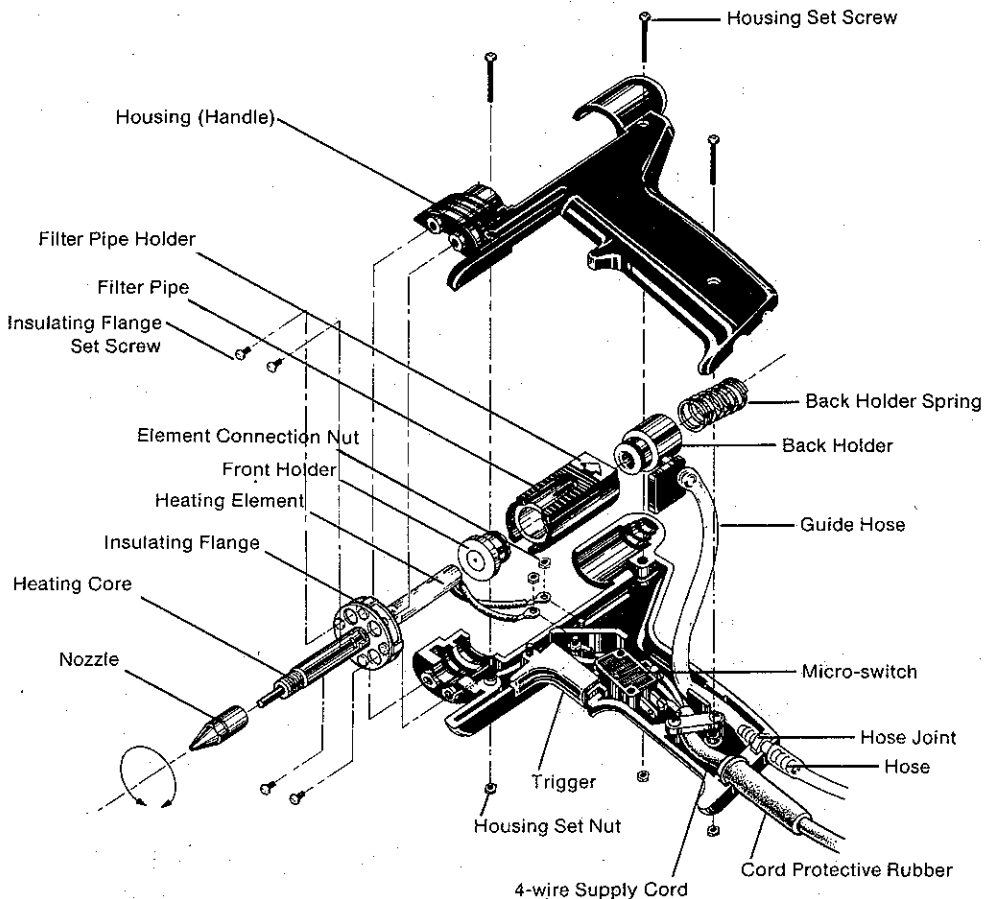

(Fig.5)

***** After Replacement of the Heating Element *****

1. Remove the fastener marked "CAL" on the back side of the pump unit.
2. Using a "minus" (−) screwdriver, turn the temperature control potentiometer to "1" (fully counterclockwise). After connecting the unit to the power supply, allow it to sit for 10 minutes.
3. Turn the temperature control potentiometer clockwise until the temperature of the desoldering iron tip reaches a stable 400° C. Use the thermometer at this time.

D) Replacement of the Heating Core

1. Remove the 4 flange set screws.
2. Remove the heating core by pulling it off gently.
3. For assembling, insert the small stainless steel pipe of the heating core into the hole in the front holder.
4. Screw the heating core with the 4 flange set screws.
5. Coat the threads of the new nozzle with the supplied anti-seizing lubricant and screw the nozzle onto the desoldering iron.

E) Cleaning and Replacement of the Vacuum Pump Diaphragm and Valve

Even though the HAKKO 707 desoldering tool incorporates a 3-ply filter structure, flux may still occasionally cling to the diaphragm or valve plate, causing the vacuum suction power to drop after several days of use.

To clean or replace the vacuum pump diaphragm and valve, follow the procedure outlined below.

1. Disconnect the power cord from the power supply.
2. Unscrew the 4 screws that secure the casing to the unit and remove the casing.
3. Pull the tube and remove it from the metal fitting.
4. Unscrew the 4 screws and remove the pump head.
5. Unscrew and remove the diaphragm adjustment plate and the diaphragm.
6. Unscrew and remove the fixing plate from inside the pump head, and remove the valve plate.
7. Clean off any flux that is adhering to the valve plate and the diaphragm with alcohol, etc. If any of the pump parts are cracked or deformed, replace them with new parts.
8. Reassembling the unit by following the disassembling steps in reverse order.

- Note:**
1. Be sure to reassemble the fixing plate in the proper direction, i.e., so that the countersink in the fixing plate is opposite the counterboard holes in the pump head.
 2. Make sure that the crank arm is at the lowest point before replacing the diaphragm, the diaphragm adjustment plate and the pump head.
 3. Apply a little silicon oil to the surfaces of the valve plate and the diaphragm before reassembling them. This will make future disassembling much easier.
 4. Be careful not to allow any dust or other foreign matter to enter the pump during reassembly.

Construction of Diaphragm

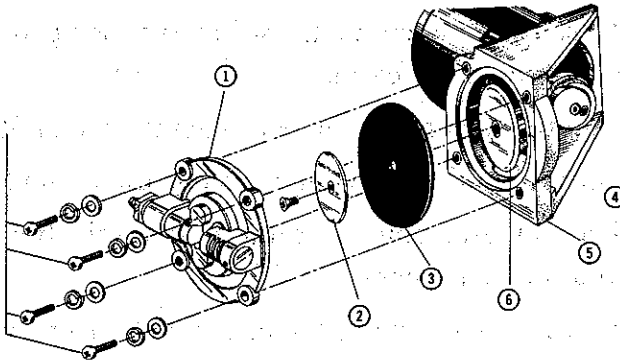

(Fig. 6)

- | | |
|--------------|-------------------------------|
| 1. Pump Head | 2. Diaphragm Adjustment Plate |
| 3. Diaphragm | 4. Balance Weight |
| 5. Pump Body | 6. Crank Arm |

Pump Head Construction

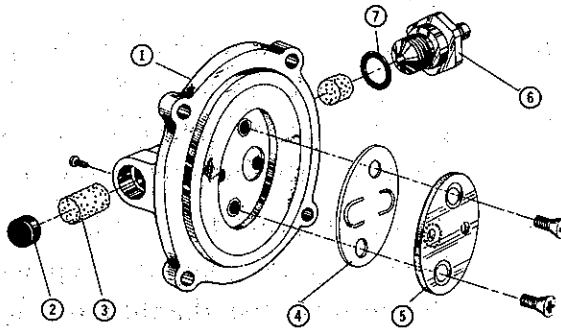

(Fig. 7)

- | | |
|--|------------------------|
| 1. Pump Head | 2. Filter Holding Plug |
| 3. Exhaust Filter | 4. Valve Plate |
| 5. Fixing Plate (Must be installed in the proper direction when reassembling.) | |
| 6. Metal Fitting for Inside-Hose Connection | |
| 7. O-Ring P-9 | |

7. Trouble Shooting Guide

Problem	Points to Check
Power switch lamp does not light up.	<ol style="list-style-type: none"> 1. Is the power cord plugged in? 2. Is the fuse blown?
Vacuum pump does not operate.	<ol style="list-style-type: none"> 1. Is the desoldering iron properly connected?
Solder is not absorbed.	<ol style="list-style-type: none"> 1. Is the vacuum pump working? 2. Is the hose properly connected? 3. Is the nozzle hot enough? 4. Is the filter pipe full of accumulated solder? 5. Are the felt filter hardened or discolored with flux? 6. Is there a vacuum leak between the filter pipe and either the front or back holder? 7. Is there a vacuum leak between the vacuum outlet retainer and the vacuum outlet cap? 8. Is the nozzle or the hole in the heating core clogged with solder?
The solder is not thoroughly melted.	<ol style="list-style-type: none"> 1. Is the desoldering iron properly connected? 2. Is the heating element broken? (If so, the nozzle will not be warm at all.) 3. Is the nozzle properly tightened? 4. Is the 4-lead cord broken? 5. Is the nozzle oxidized or become contaminated with flux?

* Should problems still exist, please contact us directly or through your sales agent.

8. Wiring Diagram

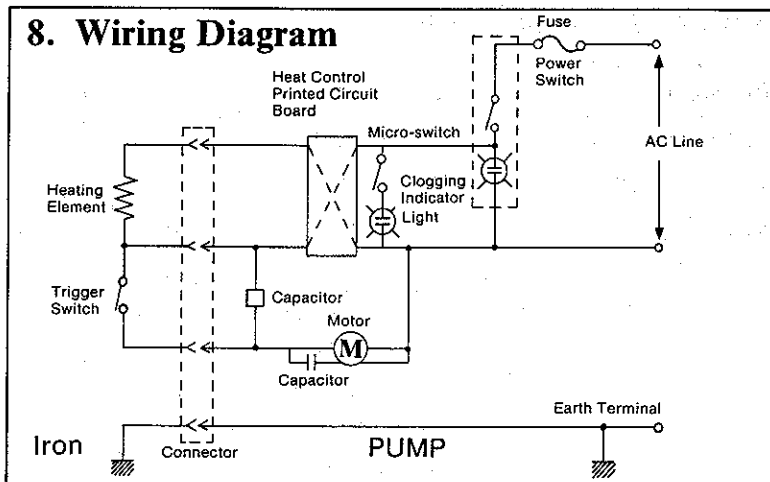

9. Replacement Parts

No.	Part Name	Specifications																				
483-T-0.8	Nozzle 0.8mm dia	 <table border="1" style="float: right;"> <thead> <tr> <th colspan="5">(mm)</th> </tr> <tr> <th></th> <th>0.8</th> <th>1.0</th> <th>1.3</th> <th>1.6</th> </tr> </thead> <tbody> <tr> <th>A</th> <td>0.8</td> <td>1.0</td> <td>1.3</td> <td>1.6</td> </tr> <tr> <th>B</th> <td>2.5</td> <td>2.5</td> <td>3.0</td> <td>3.0</td> </tr> </tbody> </table>	(mm)						0.8	1.0	1.3	1.6	A	0.8	1.0	1.3	1.6	B	2.5	2.5	3.0	3.0
(mm)																						
	0.8		1.0	1.3	1.6																	
A	0.8		1.0	1.3	1.6																	
B	2.5		2.5	3.0	3.0																	
483-T-1.0	1.0mm dia																					
483-T-1.3	1.3mm dia																					
483-T-1.6	1.6mm dia																					
481-021	Filter Set	steel wool & felt(5pcs.)																				
707-002	Filter Pipe Holder	with Filter Pipe/Filter																				
707-H	Heating Element	60W, Ceramic																				
707-012	Heating Core	with Pipe Support & Insulating flange																				
707-101	Front Holder	with O-ring																				
707-102	Back Holder	with O-ring																				
707-016	Housing (Handle)																					
707-023	Cord	4-cored Cord with Connecting Plug																				
481-103	O-ring	P-12																				
481-201	Diaphragm Set	Valve Plate, Diaphragm and Sponge Filters																				
481-013	Hose	Heat Resisting Silicon Hose																				
481-024S	Cleaning Pin -S																					
481-024L	Cleaning Pin -L																					
707-022	Holder Part																					
483-020	Cleaning Wrench																					
481-026	Anti Seizure																					

 **HAKKO**
HAKKO CORPORATION

Head office

4-5, Shiokusa 2-chome, Naniwa-ku, Osaka 556

Phone:(06)561-3225 Fax:(06)568-0821

Tokyo office

85, Kanda Sakuma-kashi, Chiyoda-ku, Tokyo 101

Phone:(03)866-1161 Fax:(03)866-1164

Sendai office

34-25, Ichu-machi, Miyagino-ku, Sendai City, Miyagi 983

Phone:(022)231-6799 Fax:(022)231-6971

Sakai factory

1-23, Higashi 1-cho, Hamaderaishizu-cho, Sakai City, Osaka 592

Phone:(0722)47-1574

U.S. affiliate American Hakko Products, Inc.

3086 North Lima St., Burbank, California 91504

Phone:(818)848-1515 Fax:(818)848-2887

Singapore affiliate Hakko Products Pte., Ltd.

246 Macpherson Rd., #02-04 Betime Building, Singapore 1334

Phone:7482277 Fax:7440033