

**SPECIFICATION**  
**FOR**  
**LCM Module**

MODULE No:	KD035VGFP094
CUSTOMER:	

STARTEK	INITIAL	DATE
PREPARED BY		
CHECKED BY		
APPROVED BY		

CUSTOMER	INITIAL	DATE
APPROVED BY		



## Contents

1.	Block Diagram .....	5
2.	Outline dimension.....	6
3.	Input terminal Pin Assignment .....	7
4.	LCD Optical Characteristics.....	9
4.1	Optical specification.....	9
5.	Electrical Characteristics .....	11
5.1	Absolute Maximum Rating.....	11
5.2	DC Electrical Characteristics .....	11
5.3	LED Backlight Characteristics .....	12
6.	AC Characteristics.....	14
6.1	Display Serial Interface Timing Characteristics (3-line SPI system) .....	14
6.2	Parallel 24/18/16-bit RGB Interface Timing Characteristics .....	15
6.3	DPI Interface Timing .....	16
6.4	Reset timing .....	17
7.	LCD Module Out-Going Quality Level.....	18
7.1	VISUAL & FUNCTION INSPECTION STANDARD .....	18
7.1.1	Inspection conditions .....	18
7.1.3	Sampling Plan .....	19
7.1.4	Criteria (Visual).....	20
8.	Reliability Test Result .....	25
9.	Cautions and Handling Precautions.....	26
9.1	Handling and Operating the Module .....	26
9.2	Storage and Transportation. ....	26
10.	Packing.....	27

Part. No	KD035VGFP A094	REV	V1.1	Page 3 of 27
	常备库存 Stock For Sale	长期供货 Long Time supply	支持小量 NO MOQ	品种齐全 In Full Range

### \* Description

This is a color active matrix TFT (Thin Film Transistor) LCD (liquid crystal display) that uses amorphous silicon TFT as a switching device. This module is composed of a BlanView type TFT-LCD Panel, driver circuit, back-light unit. The resolution of a 3.5 " TFT-LCD contains 480x640 pixels, and can display up to 16.7M colors.

### \* Features

General Information Items	Specification	Unit	Note
	Main Panel		
Display area(AA)	53.28(H)*71.04(V) (3.5 inch)	mm	
Driver element	TFT active matrix	-	
Display colors	65K/262K/16.7M	colors	
Number of pixels	480(RGB)*640	dots	
Pixel arrangement	RGB vertical stripe	-	
Pixel pitch	0.111(H)*0.111(V)	mm	
Viewing angle	VA	o'clock	
Controller IC	ILI9806E	-	
LCM Interface	3SPI+16/18/24BIT RGB	-	
Display mode	Blan View /Normally Black	-	
Operating temperature	-20~+70	°C	
Storage temperature	-30~+80	°C	

### \* Mechanical Information

Item		Min.	Typ.	Max.	Unit	Note
Module size	Horizontal(H)	-	64	-	mm	
	Vertical(V)	-	85	-	mm	
	Depth(D)	-	3.1	-	mm	
Weight		-	TBD	-	g	

Part. No	KD035VGFP A094	REV	V1.1	Page 4 of 27
常备库存 Stock For Sale	长期供货 Long Time supply	支持小量 NO MOQ	品种齐全 In Full Range	

**1. Block Diagram**

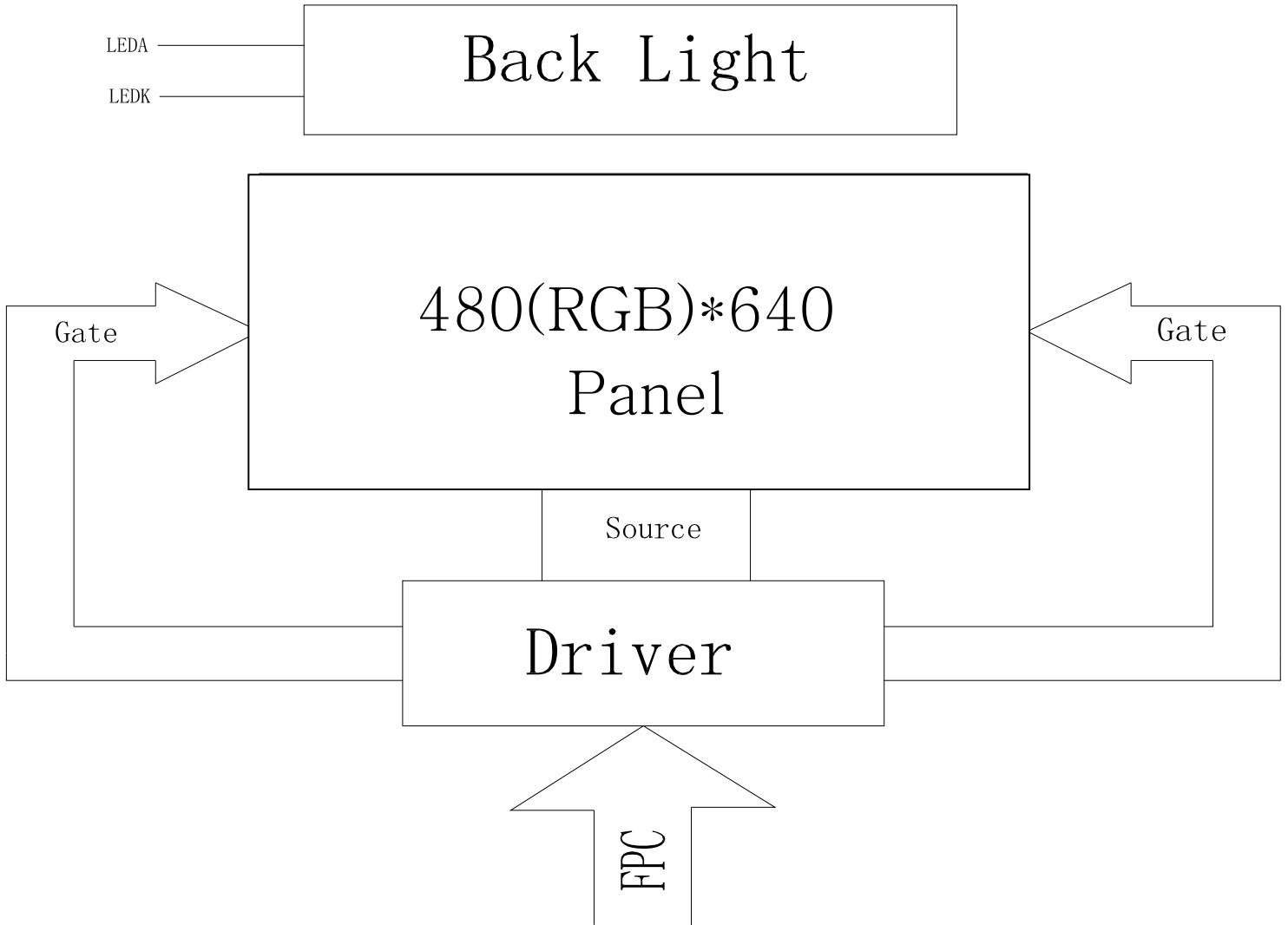

Part. No	KD035VGFP094	REV	V1.1	Page 5 of 27
常备库存 Stock For Sale	长期供货 Long Time supply	支持小量 NO MOQ	品种齐全 In Full Range	

2. Outline dimension

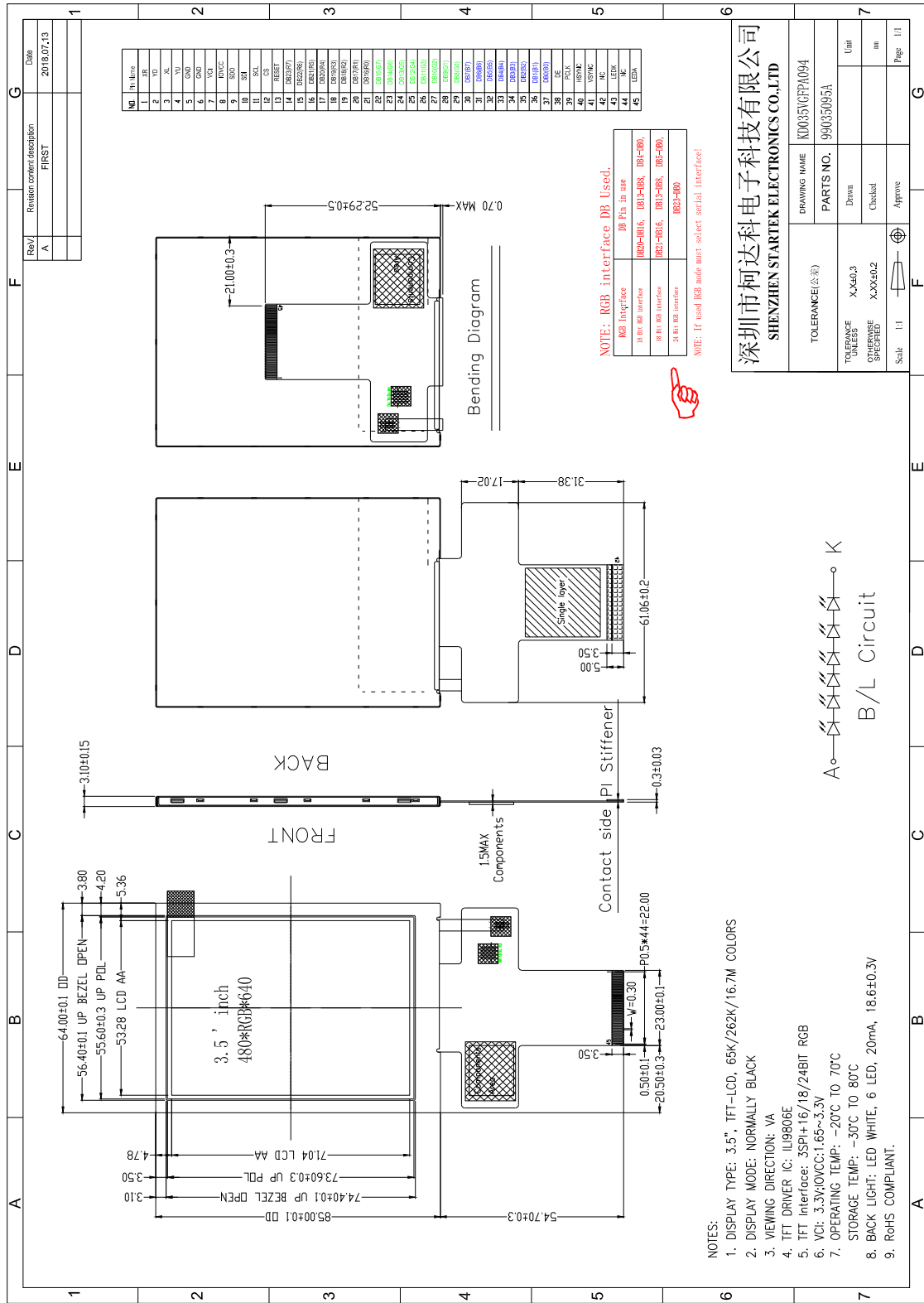

Part. No	KD035VGFPA094	REV	V1.1	Page 6 of 27
常备库存 Stock For Sale	长期供货 Long Time supply	支持小量 NO MOQ	品种齐全 In Full Range	

### 3. Input terminal Pin Assignment

NO.	SYMBOL	DISCRIPTION	I/O
1	XR(NC)	Touch panel Right Glass Terminal	A/D
2	YD(NC)	Touch panel Bottom Film Terminal	A/D
3	XL(NC)	Touch panel LIFT Glass Terminal	A/D
4	YU(NC)	Touch panel Top Film Terminal	A/D
5	GND	Ground.	P
6	GND	Ground.	P
7	VCI	Supply voltage (3.3V).	P
8	IOVCC	I/O power supply voltage.	P
9	SDO	SPI interface output pin.-The data is output on the falling edge of the SCL signal.-If not used, let this pin open.	O
10	SDI	Data lane in 1 data lane serial interface. The data is latched on the rising edge of the SCL signal.	I
11	SCL	This pin is used to select "Data or Command" in the parallel interface. When D/CX = '1', data is selected. When D/CX = '0', command is selected. This pin is used serial interface clock in 3-wire 9-bit / 4-wire 8-bit serial data interface. fix this pin at IOVCC or GND when not in use.	I
12	CS	Chip select input pin ("Low" enable). fix this pin at IOVCC or GND when not in use.	I
13	RESET	Reset pin. Setting either pin low initializes the LSI. Must be reset after power is supplied.	I
14-37	DB23-DB0	24-bit parallel bi-directional data bus for MCU system and RGB interface mode .Fix to GND level when not in use	I/O
38	DE	Data enable signal for RGB interface operation. fix this pin at IOVC or GND when not in use.	I
39	DOTCLK	Dot clock signal for RGB interface operation. Fix this pin at VCI or GND when not in use.	I
40	HSYNC	Line synchronizing signal for RGB interface operation. fix this pin at IOVCC or GND when not in use.	I
41	VSYNC	Frame synchronizing signal for RGB interface operation. fix this pin at IOVCC or GND when not in use.	I
42	NC		

Part. No	KD035VGFP A094	REV	V1.1	Page 7 of 27
常备库存 Stock For Sale	长期供货 Long Time supply	支持小量 NO MOQ	品种齐全 In Full Range	

43	LEDK	Cathode pin of backlight.	P
44	NC		
45	LEDA	Anode pin of backlight.	P



## 4. LCD Optical Characteristics

### 4.1 Optical specification

Item	Symbol	Condition	Min.	Typ.	Max.	Unit.	Note
Contrast Ratio	CR	$\Theta=0$	500	700	--		2
Response time	Rising	Normal viewing angle	--	25	--	msec	3
	Falling						
Uniformity	S(%)		--	51.7	--	%	
Color Filter Chromacicity	White	$W_X$	0.2594	0.2994	0.3394		
		$W_Y$	0.2899	0.3299	0.3699		
	Red	$R_X$	0.4975	0.5375	0.5775		
		$R_Y$	0.2928	0.3328	0.3728		
	Green	$G_X$	0.2970	0.3370	0.3770		
		$G_Y$	0.5346	0.5746	0.6146		
	Blue	$B_X$	0.1139	0.1539	0.1939		
		$B_Y$	0.0746	0.1146	0.1546		
Viewing angle	Hor.	$\Theta_L$	--	80	--		
		$\Theta_R$	--	80	--		
	Ver.	$\Theta_U$	--	80	--		
		$\Theta_D$	--	80	--		
Option View Direction	VA						

Part. No	KD035VGFP A094	REV	V1.1	Page 9 of 27
常备库存 Stock For Sale	长期供货 Long Time supply	支持小量 NO MOQ	品种齐全 In Full Range	

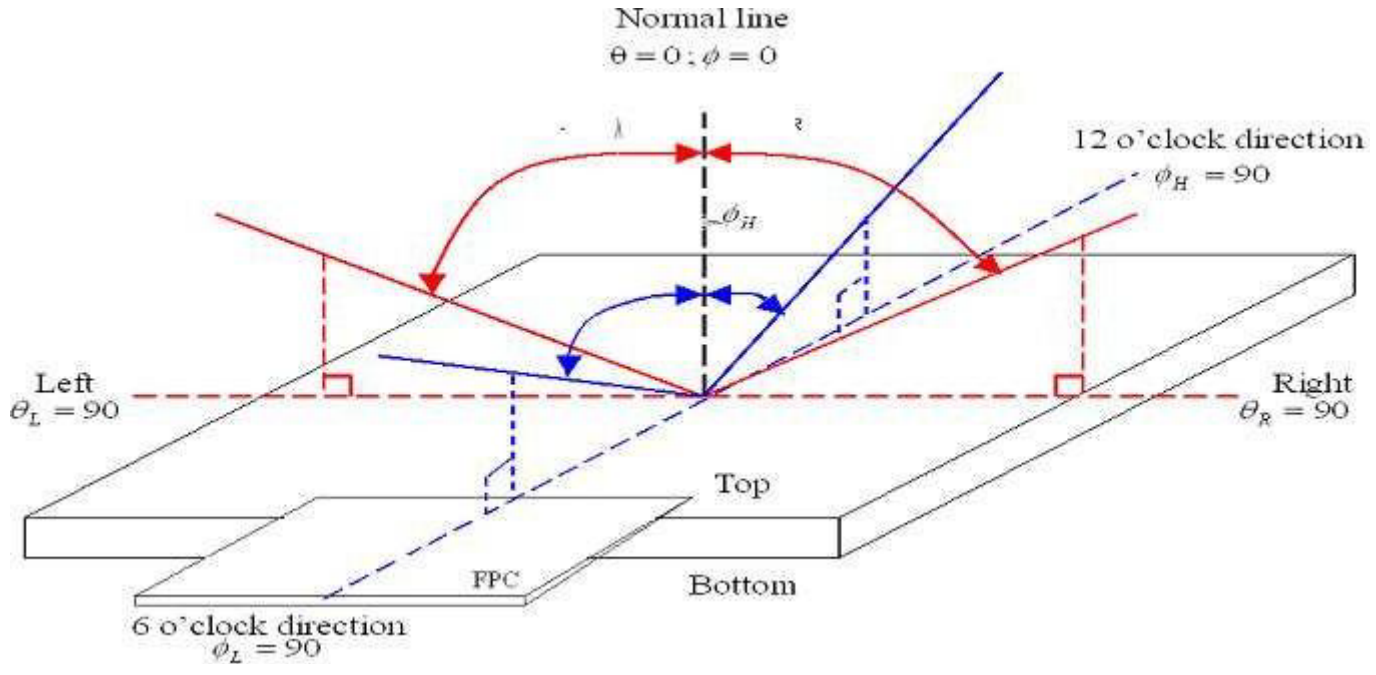

Note (2) Definition of Contrast Ratio (CR) :  
measured at the center point of panel

$$CR = \frac{\text{Luminance with all pixels white}}{\text{Luminance with all pixels black}}$$

Note (3) Definition of Response Time : Sum of  $T_R$  and  $T_F$

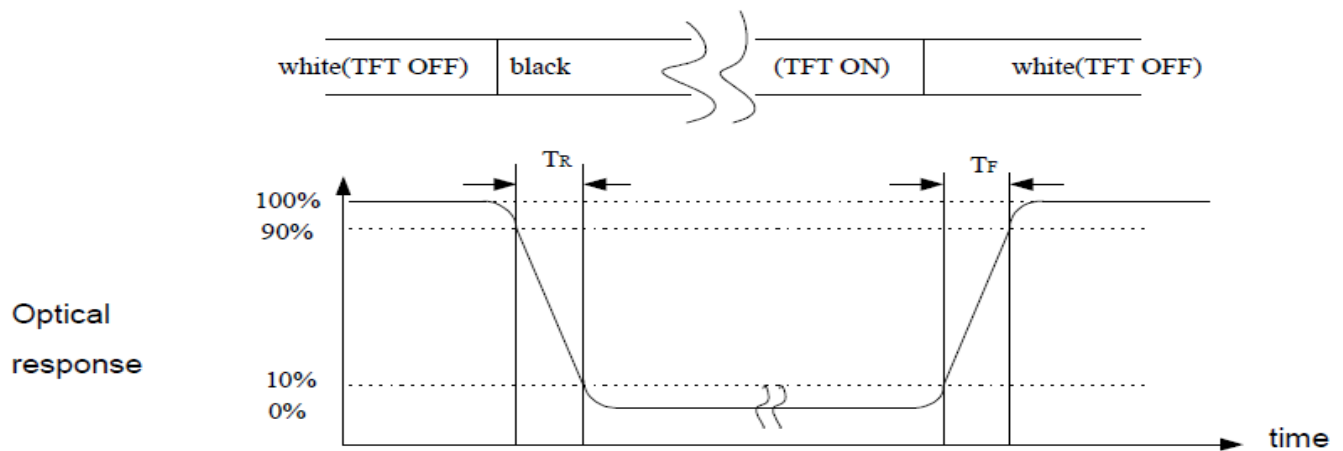

Part. No	KD035VGFP A094	REV	V1.1	Page 10 of 27
常备库存 Stock For Sale	长期供货 Long Time supply	支持小量 NO MOQ	品种齐全 In Full Range	

## 5. Electrical Characteristics

### 5.1 Absolute Maximum Rating

Characteristics	Symbol	Min.	Max.	Unit	Note
Digital Supply Voltage	VCI	-0.3	4.6	V	Note1
Digital interface supply Voltage	IOVCC	-0.3	4.6	V	Note1
Operating temperature	T <sub>OP</sub>	-20	+70	°C	
Storage temperature	T <sub>ST</sub>	-30	+80	°C	

NOTE1: If the absolute maximum rating of even is one of the above parameters is exceeded even momentarily, the quality of the product may be degraded. Absolute maximum ratings, therefore, specify the values exceeding which the product may be physically damaged. Be sure to use the product within the range of the absolute maximum ratings.

### 5.2 DC Electrical Characteristics

Characteristics	Symbol	Min.	Typ.	Max.	Unit	Note
Digital Supply Voltage	VCI	2.5	3.3	3.6	V	
Digital Interface Supply Voltage	IOVCC	1.65	1.8	3.6	V	
Normal mode Current	IDD	--	20	--	mA	
Level input voltage	V <sub>IH</sub>	0.7 IOVCC	-	IOVCC	V	
	V <sub>IL</sub>	GND	-	0.3 IOVCC	V	
Level output voltage	V <sub>OH</sub>	0.8 IOVCC	-	IOVCC	V	
	V <sub>OL</sub>	GND	-	0.2 IOVCC	V	

Part. No	KD035VGFP A094	REV	V1.1	Page 11 of 27
常备库存 Stock For Sale	长期供货 Long Time supply	支持小量 NO MOQ	品种齐全 In Full Range	

### 5.3 LED Backlight Characteristics

The back-light system is edge-lighting type with 6 chips LED

Item	Symbol	Min.	Typ.	Max.	Unit	Note
Forward Current	$I_F$	15	20	--	mA	
Forward Voltage	$V_F$	--	18.6	--	V	
LCM Luminance ( $I_F = 20\text{mA}$ )	LV	370	420	--	cd/m <sup>2</sup>	Note3
LED life time	Hr	--	50000	--	Hour	Note1,2
Uniformity	Avg	80	--	--	%	Note3

Note1: LED life time (Hr) can be defined as the time in which it continues to operate under the condition:

$T_a = 25 \pm 3 \text{ } ^\circ\text{C}$ , typical IL value indicated in the above table until the brightness becomes less than 50%.

Note 2: The "LED life time" is defined as the module brightness decrease to 50% original brightness at

$T_a = 25 \text{ } ^\circ\text{C}$  and  $I_L = 20\text{mA}$ . The LED lifetime could be decreased if operating  $I_L$  is larger than 20mA. The constant current driving method is suggested.

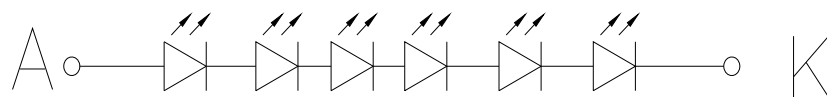

B/L Circuit

Part. No	KD035VGFP A094	REV	V1.1	Page 12 of 27
常备库存 Stock For Sale	长期供货 Long Time supply	支持小量 NO MOQ	品种齐全 In Full Range	

Note (3) Luminance Uniformity of these 9 points is defined as below:

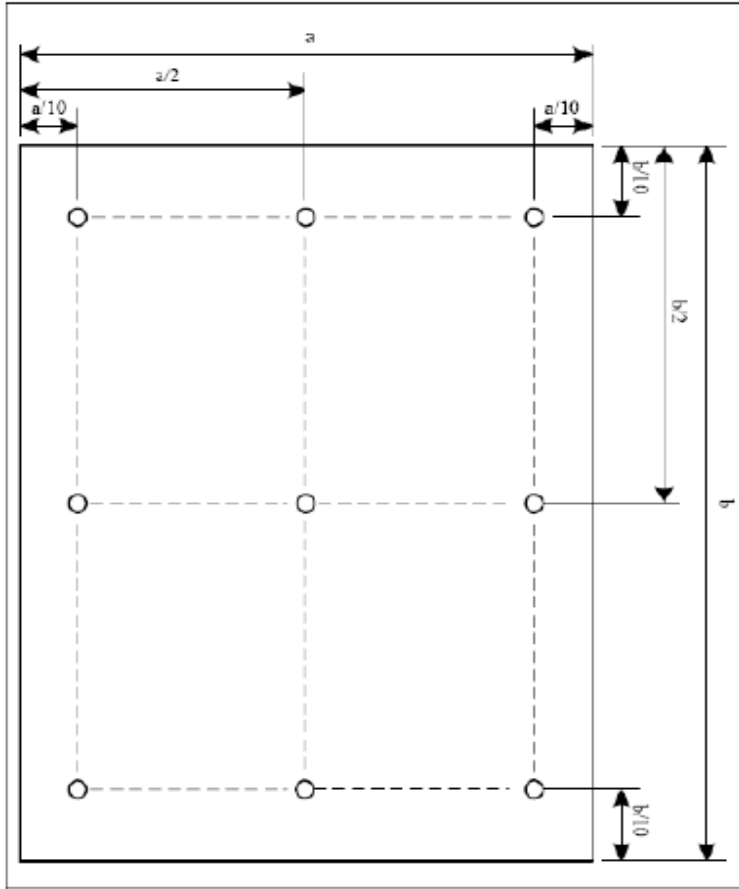

$$\text{Uniformity} = \frac{\text{minimum luminance in 9 points (1-9)}}{\text{maximum luminance in 9 points (1-9)}}$$

$$\text{Luminance} = \frac{\text{Total Luminance of 9 points}}{9}$$

Part. No	KD035VGFP A094	REV	V1.1	Page 13 of 27
常备库存 Stock For Sale	长期供货 Long Time supply	支持小量 NO MOQ	品种齐全 In Full Range	

## 6. AC Characteristics

### 6.1 Display Serial Interface Timing Characteristics (3-line SPI system)

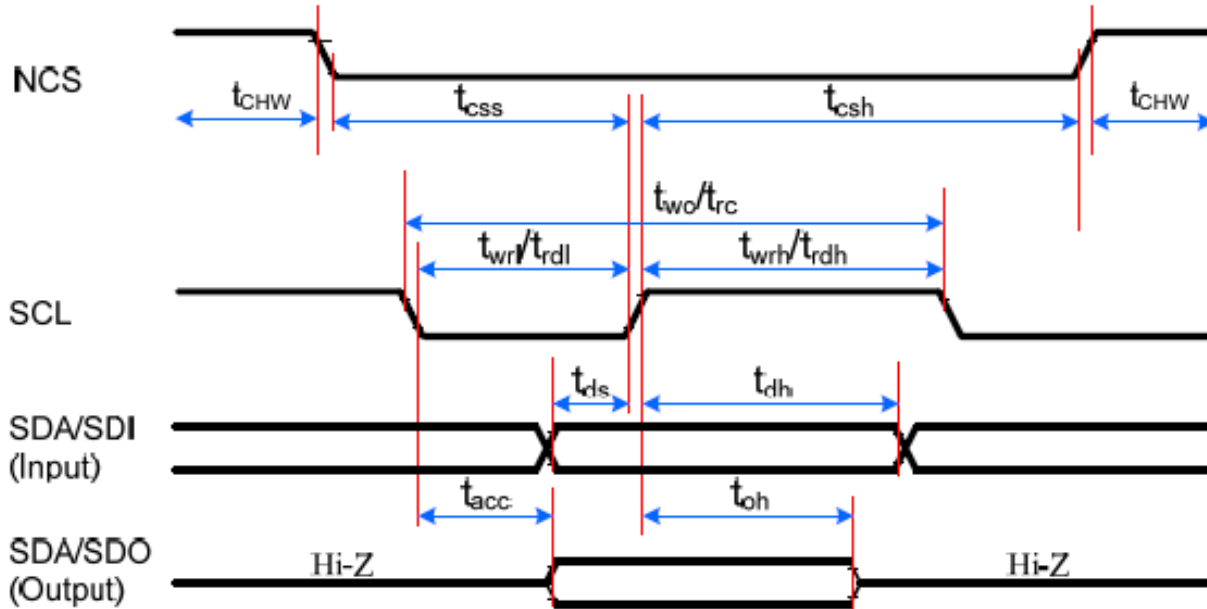

Signal	Symbol	Parameter	min	max	Unit	Description
CSX	$t_{css}$	Chip select time (Write)	15	-	ns	
	$t_{csh}$	Chip select hold time (Read)	15	-	ns	
	$t_{CHW}$	CS "H" pulse width	40	-	ns	
SCL	$t_{wc}$	Serial clock cycle (Write)	30	-	ns	
	$t_{wrh}$	SCL "H" pulse width (Write)	10	-	ns	
	$t_{wrl}$	SCL "L" pulse width (Write)	10	-	ns	
	$t_{rc}$	Serial clock cycle (Read)	150	-	ns	
	$t_{rdh}$	SCL "H" pulse width (Read)	60	-	ns	
	$t_{rdl}$	SCL "L" pulse width (Read)	60	-	ns	
SDA/SDO (Output)	$t_{acc}$	Access time (Read)	10	100	ns	For maximum CL=30pF
	$t_{oh}$	Output disable time (Read)	15	100	ns	For minimum CL=8pF
SDA/SDI (Input)	$t_{ds}$	Data setup time (Write)	10	-	ns	
	$t_{dh}$	Data hold time (Write)	10	-	ns	

Note:

- $T_a = -30$  to  $70$  °C,  $IOVCC=1.65V$  to  $3.6V$ ,  $VCI=2.5V$  to  $3.6V$ ,  $T=10\pm 0.5ns$ .
- Does not include signal rise and fall times.

Part. No	KD035VGFP A094	REV	V1.1	Page 14 of 27
常备库存 Stock For Sale	长期供货 Long Time supply	支持小量 NO MOQ	品种齐全 In Full Range	

## 6.2 Parallel 24/18/16-bit RGB Interface Timing Characteristics

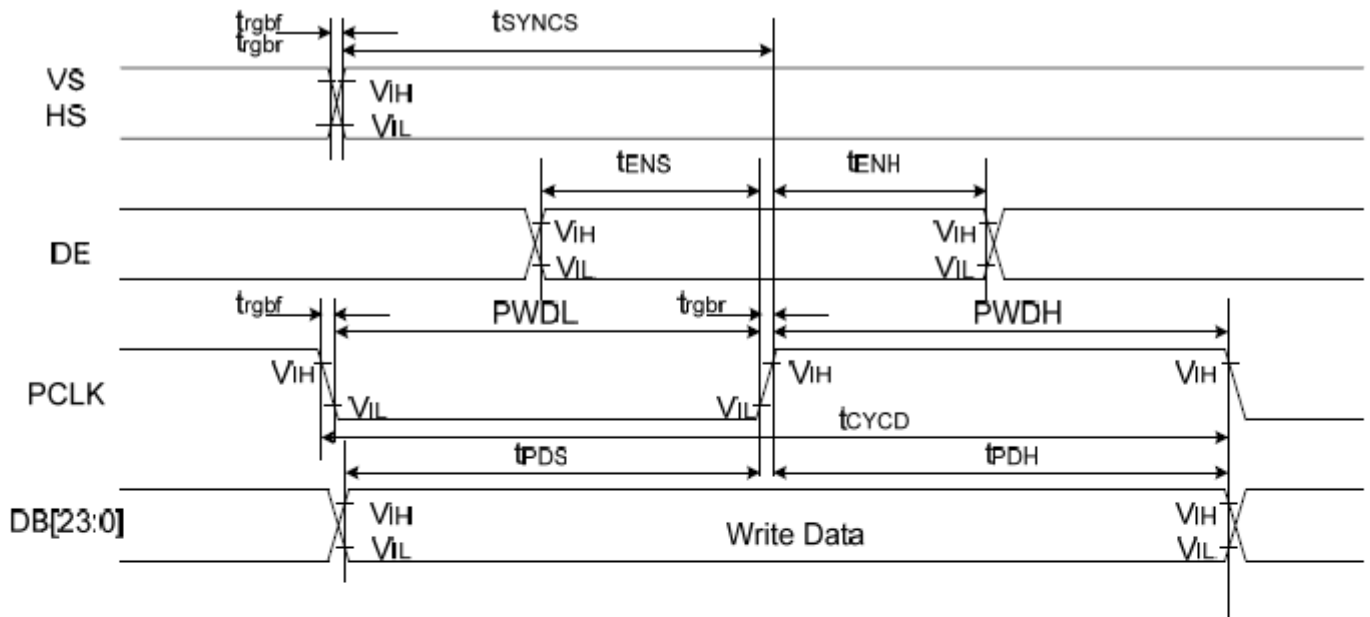

Signal	Symbol	Parameter	min	max	Unit	Description
VS/ HS	$t_{SYNCS}$	VS/HS setup time	5	-	ns	24/18/16-bit bus RGB interface mode
	$t_{SYNCH}$	VS/HS hold time	5	-	ns	
DE	$t_{ENS}$	DE setup time	5	-	ns	
	$t_{ENH}$	DE hold time	5	-	ns	
DB[23:0]	$t_{POS}$	Data setup time	5	-	ns	
	$t_{PDH}$	Data hold time	5	-	ns	
PCLK	$PWDH$	PCLK high-level period	13	-	ns	
	$PWDL$	PCLK low-level period	13	-	ns	
	$t_{CYCD}$	PCLK cycle time	28	-	ns	
	$t_{rgbf}, t_{rgbr}$	PCLK,HS,VS rise/fall time	-	15	ns	

Note:  $T_a = -30$  to  $70$  °C,  $IOVCC=1.65V$  to  $3.6V$ ,  $VCI=2.5V$  to  $3.6V$ ,  $DGND=0V$

Part. No	KD035VGFP A094	REV	V1.1	Page 15 of 27
常备库存 Stock For Sale	长期供货 Long Time supply	支持小量 NO MOQ	品种齐全 In Full Range	

### 6.3 DPI Interface Timing

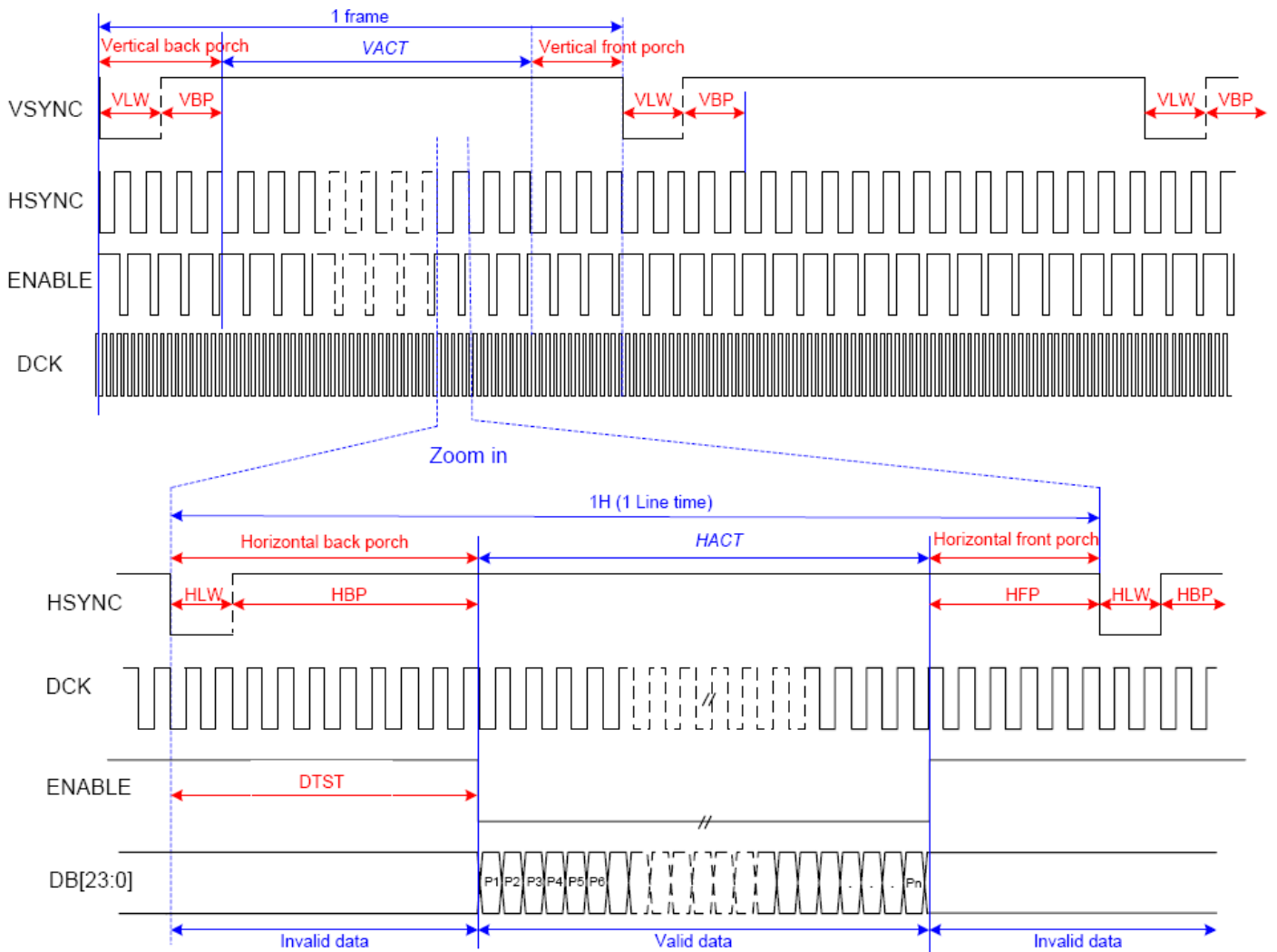

VLW : VSYNC Low pulse Width  
 HLW : HSYNC Low pulse Width  
 DTST : Data Transfer Startup Time  
 Pn : pixel 1, pixel 2..., pixel n.

Parameter	Symbols	Condition	Min.	Typ.	Max.	Units
Frame Rate	FR		54		66	fps
Horizontal Low Pulse width	HLW		1		-	DOTCLK
Horizontal Back Porch	HBP		2		126	DOTCLK
Horizontal Address	HACT			480		DOTCLK
Horizontal Front Porch	HFP		2		-	DOTCLK
Vertical Low Pulse width	VLW		1		126	Line
Vertical Back Porch	VBP		1		126	Line
Vertical Address	VACT				864	Line
Vertical Front Porch	VFP		1		255	Line
Data Clock	DCLK		16.6		41.7	MHz

Part. No	KD035VGFP A094	REV	V1.1	Page 16 of 27
常备库存 Stock For Sale	长期供货 Long Time supply	支持小量 NO MOQ	品种齐全 In Full Range	



## 6.4 Reset timing

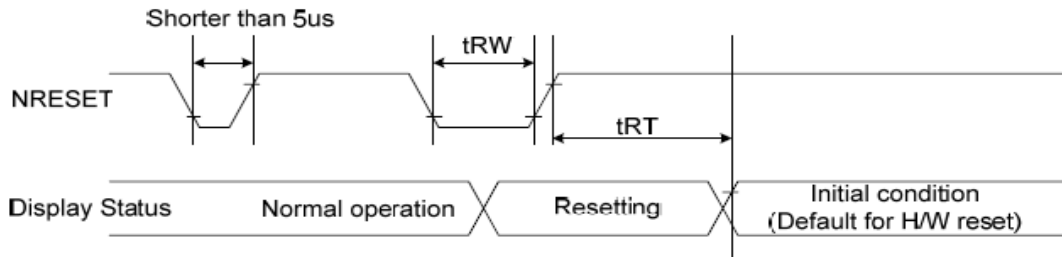

Figure 102 Reset Timing

Table 41 Reset Timing

Signal	Symbol	Parameter	Min	Max	Unit
RESX	tRW	Reset pulse duration	10		us
	tRT	Reset cancel		5(note 1,5)	ms
				120 (note 1,6,7)	ms

Note:

1. The reset cancel includes also required time for loading ID bytes, VCOM setting and other settings from OTP to registers. This loading is done every time when there is H/W reset cancel time (tRT) within 5 ms after a rising edge of RESX.
2. Spike due to an electrostatic discharge on RESX line does not cause irregular system reset according to the Table 43.

Table 42 Reset Descript

RESX Pulse	Action
Shorter than 5us	Reset Rejected
Longer than 9us	Reset
Between 5us and 9us	Reset starts

3. During the Resetting period, the display will be blanked (The display is entering blanking sequence, which maximum time is 120 ms, when Reset Starts in Sleep Out mode. The display remains the blank state in Sleep In mode.) and then return to Default condition for Hardware Reset.
4. Spike Rejection also applies during a valid reset pulse as shown below:

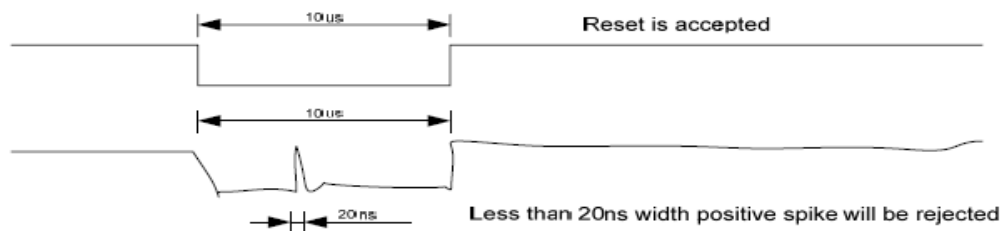

Figure 103 Positive Noise Pulse during Reset Low

5. When Reset applied during Sleep In Mode.
6. When Reset applied during Sleep Out Mode.
7. It is necessary to wait 5msec after releasing RESX before sending commands. Also Sleep Out command cannot be sent for 120msec.

Part. No	KD035VGFP A094	REV	V1.1	Page 17 of 27
常备库存 Stock For Sale	长期供货 Long Time supply	支持小量 NO MOQ	品种齐全 In Full Range	

## 7. LCD Module Out-Going Quality Level

### 7.1 VISUAL & FUNCTION INSPECTION STANDARD

#### 7.1.1 Inspection conditions

Inspection performed under the following conditions is recommended.

Temperature :  $25\pm 5^{\circ}\text{C}$

Humidity :  $65\%\pm 10\%\text{RH}$

Viewing Angle : Normal viewing Angle.

Illumination: Single fluorescent lamp (300 to 700Lux)

Viewing distance:30-50cm

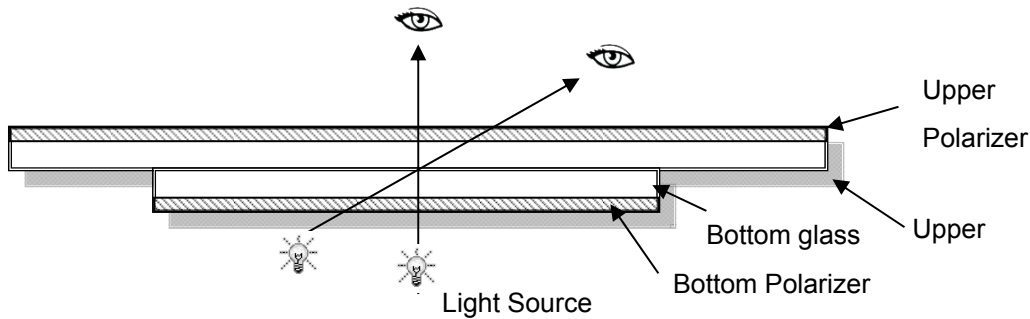

#### 7.1.2 Definition

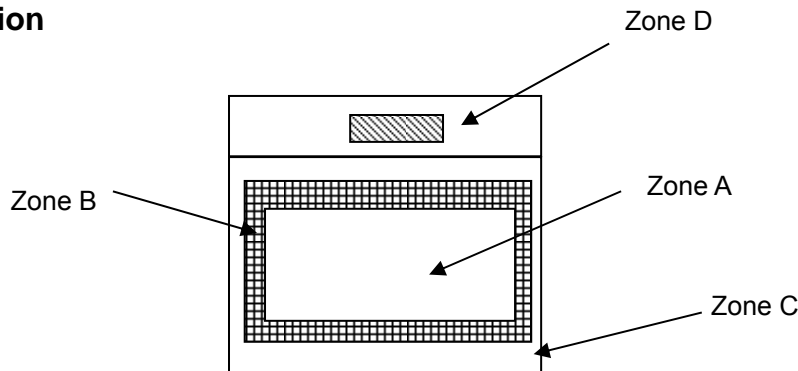

Zone A : Effective Viewing Area(Character or Digit can be seen)

Zone B : Viewing Area except Zone A

Zone C : Outside (Zone A+Zone B) which can not be seen after assembly by customer .)

Zone D : IC Bonding Area

Note:As a general rule ,visual defects in Zone C can be ignored when it doesn't effect product function or appearance after assembly by customer

Part. No	KD035VGFP A094	REV	V1.1	Page 18 of 27
常备库存 Stock For Sale	长期供货 Long Time supply	支持小量 NO MOQ	品种齐全 In Full Range	

### 7.1.3 Sampling Plan

According to GB/T 2828.1-2003 ; , normal inspection, Class II

AQL:

Major defect	Minor defect
0.65	1.5

LCD: Liquid Crystal Display , TP: Touch Panel , LCM: Liquid Crystal Module

No	Items to be inspected	Criteria	Classification of defects
1	Functional defects	1) No display, Open or miss line 2) Display abnormally, Short 3) Backlight no lighting, abnormal lighting. 4) TP no function	Major
2	Missing	Missing component	
3	Outline dimension	Overall outline dimension beyond the drawing is not allowed	
4	Color tone	Color unevenness, refer to limited sample	Minor
5	Spot Line defect	Light dot, Dim spot, Polarizer Bubble ; Polarizer accidented spot.	
6	Soldering appearance	Good soldering , Peeling off is not allowed.	
7	LCD/Polarizer/TP	Black/White spot/line, scratch, crack, etc.	

### 7.1.4 Criteria (Visual)

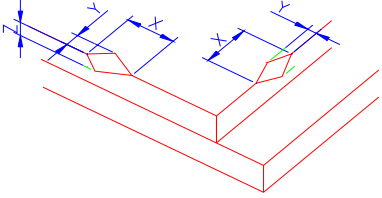
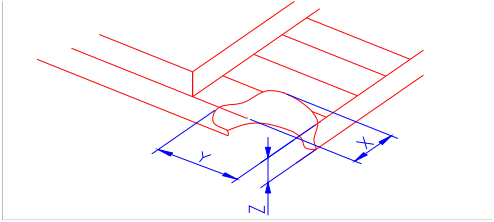
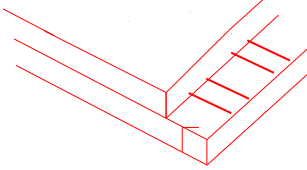

Number	Items	Criteria(mm)						
1.0 LCD Crack/Broken NOTE: X: Length Y: Width Z: Height L: Length of ITO, T: Height of LCD	(1) The edge of LCD broken	 <table border="1" data-bbox="756 667 1455 817"> <thead> <tr> <th>X</th> <th>Y</th> <th>Z</th> </tr> </thead> <tbody> <tr> <td>≤3.0mm</td> <td>&lt;Inner border line of the seal</td> <td>≤T</td> </tr> </tbody> </table>	X	Y	Z	≤3.0mm	<Inner border line of the seal	≤T
X	Y	Z						
≤3.0mm	<Inner border line of the seal	≤T						
	(2)LCD corner broken	 <table border="1" data-bbox="836 1122 1375 1223"> <thead> <tr> <th>X</th> <th>Y</th> <th>Z</th> </tr> </thead> <tbody> <tr> <td>≤3.0mm</td> <td>≤L</td> <td>≤T</td> </tr> </tbody> </table>	X	Y	Z	≤3.0mm	≤L	≤T
X	Y	Z						
≤3.0mm	≤L	≤T						
	(3) LCD crack	 <p style="text-align: center;">Crack Not allowed</p>						

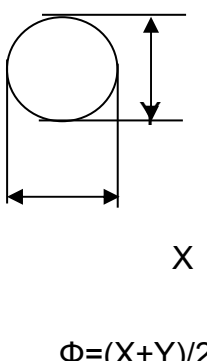

2.0	Spot defect	① light dot (LCD/TP/Polarizer black/white spot , light dot, pinhole, dent, stain)																							
		<table border="1"> <thead> <tr> <th rowspan="2">Zone Size (mm)</th> <th colspan="3">Acceptable Qty</th> </tr> <tr> <th>A</th> <th>B</th> <th>C</th> </tr> </thead> <tbody> <tr> <td><math>\Phi \leq 0.10</math></td> <td colspan="3">Ignore</td> </tr> <tr> <td><math>0.10 &lt; \Phi \leq 0.25</math></td> <td colspan="3">3( distance <math>\geq 10\text{mm}</math>)</td> </tr> <tr> <td><math>0.25 &lt; \Phi \leq 0.3</math></td> <td colspan="3">2</td> </tr> <tr> <td><math>\Phi &gt; 0.35</math></td> <td colspan="3">0</td> </tr> </tbody> </table>	Zone Size (mm)	Acceptable Qty			A	B	C	$\Phi \leq 0.10$	Ignore			$0.10 < \Phi \leq 0.25$	3( distance $\geq 10\text{mm}$ )			$0.25 < \Phi \leq 0.3$	2			$\Phi > 0.35$	0		
	Zone Size (mm)	Acceptable Qty																							
		A	B	C																					
	$\Phi \leq 0.10$	Ignore																							
$0.10 < \Phi \leq 0.25$	3( distance $\geq 10\text{mm}$ )																								
$0.25 < \Phi \leq 0.3$	2																								
$\Phi > 0.35$	0																								
	② Dim spot (LCD/TP/Polarizer dim dot, light leakage, dark spot)																								
	<table border="1"> <thead> <tr> <th rowspan="2">Zone Size (mm)</th> <th colspan="3">Acceptable Qty</th> </tr> <tr> <th>A</th> <th>B</th> <th>C</th> </tr> </thead> <tbody> <tr> <td><math>\Phi \leq 0.1</math></td> <td colspan="3">Ignore</td> </tr> <tr> <td><math>0.10 &lt; \Phi \leq 0.25</math></td> <td colspan="3">3( distance <math>\geq 10\text{mm}</math>)</td> </tr> <tr> <td><math>0.25 &lt; \Phi \leq 0.3</math></td> <td colspan="3">2</td> </tr> <tr> <td><math>\Phi &gt; 0.35</math></td> <td colspan="3">0</td> </tr> </tbody> </table>	Zone Size (mm)	Acceptable Qty			A	B	C	$\Phi \leq 0.1$	Ignore			$0.10 < \Phi \leq 0.25$	3( distance $\geq 10\text{mm}$ )			$0.25 < \Phi \leq 0.3$	2			$\Phi > 0.35$	0			
Zone Size (mm)	Acceptable Qty																								
	A	B	C																						
$\Phi \leq 0.1$	Ignore																								
$0.10 < \Phi \leq 0.25$	3( distance $\geq 10\text{mm}$ )																								
$0.25 < \Phi \leq 0.3$	2																								
$\Phi > 0.35$	0																								
	③ Polarizer accidented spot																								
	<table border="1"> <thead> <tr> <th rowspan="2">Zone Size (mm)</th> <th colspan="3">Acceptable Qty</th> </tr> <tr> <th>A</th> <th>B</th> <th>C</th> </tr> </thead> <tbody> <tr> <td><math>\Phi \leq 0.2</math></td> <td colspan="3">Ignore</td> </tr> <tr> <td><math>0.3 &lt; \Phi \leq 0.5</math></td> <td colspan="3">2( distance <math>\geq 10\text{mm}</math>)</td> </tr> <tr> <td><math>\Phi &gt; 0.5</math></td> <td colspan="3">0</td> </tr> </tbody> </table>	Zone Size (mm)	Acceptable Qty			A	B	C	$\Phi \leq 0.2$	Ignore			$0.3 < \Phi \leq 0.5$	2( distance $\geq 10\text{mm}$ )			$\Phi > 0.5$	0							
Zone Size (mm)	Acceptable Qty																								
	A	B	C																						
$\Phi \leq 0.2$	Ignore																								
$0.3 < \Phi \leq 0.5$	2( distance $\geq 10\text{mm}$ )																								
$\Phi > 0.5$	0																								
	④ Pixel bad points (light dot, Dim dot, color dot)																								
	<table border="1"> <thead> <tr> <th rowspan="2">Zone Size (mm)</th> <th colspan="3">Acceptable Qty</th> </tr> <tr> <th>A</th> <th>B</th> <th>C</th> </tr> </thead> <tbody> <tr> <td><math>\Phi \leq 0.1</math></td> <td colspan="3">Ignore</td> </tr> <tr> <td><math>0.15 &lt; \Phi \leq 0.25</math></td> <td colspan="3">2( distance <math>\geq 10\text{mm}</math>)</td> </tr> <tr> <td><math>\Phi &gt; 0.3</math></td> <td colspan="3">0</td> </tr> </tbody> </table>	Zone Size (mm)	Acceptable Qty			A	B	C	$\Phi \leq 0.1$	Ignore			$0.15 < \Phi \leq 0.25$	2( distance $\geq 10\text{mm}$ )			$\Phi > 0.3$	0							
Zone Size (mm)	Acceptable Qty																								
	A	B	C																						
$\Phi \leq 0.1$	Ignore																								
$0.15 < \Phi \leq 0.25$	2( distance $\geq 10\text{mm}$ )																								
$\Phi > 0.3$	0																								
	⑤ Polarizer Bubble																								
	<table border="1"> <thead> <tr> <th rowspan="2">Zone Size (mm)</th> <th colspan="3">Acceptable Qty</th> </tr> <tr> <th>A</th> <th>B</th> <th>C</th> </tr> </thead> <tbody> <tr> <td><math>\Phi \leq 0.2</math></td> <td colspan="3">Ignore</td> </tr> <tr> <td><math>0.3 &lt; \Phi \leq 0.4</math></td> <td colspan="3">3(distance <math>\geq 10\text{mm}</math>)</td> </tr> <tr> <td><math>0.4 &lt; \Phi \leq 0.5</math></td> <td colspan="3">2</td> </tr> <tr> <td><math>\Phi &gt; 0.5</math></td> <td colspan="3">0</td> </tr> </tbody> </table>	Zone Size (mm)	Acceptable Qty			A	B	C	$\Phi \leq 0.2$	Ignore			$0.3 < \Phi \leq 0.4$	3(distance $\geq 10\text{mm}$ )			$0.4 < \Phi \leq 0.5$	2			$\Phi > 0.5$	0			
Zone Size (mm)	Acceptable Qty																								
	A	B	C																						
$\Phi \leq 0.2$	Ignore																								
$0.3 < \Phi \leq 0.4$	3(distance $\geq 10\text{mm}$ )																								
$0.4 < \Phi \leq 0.5$	2																								
$\Phi > 0.5$	0																								

3.0	Line defect (LCD/TP /Polarizer backlight black/white line, scratch, stain)	Width(mm)	Length(m m)	Acceptable Qty		
				A	B	C
		$\Phi \leq 0.05$	Ignore	Ignore		
		$0.05 < W \leq 0.06$	$L \leq 3.0$	$N \leq 2$		
		$0.07 < W \leq 0.08$	$L \leq 2.0$	$N \leq 1$		
		$0.08 < W$	Define as spot defect			
4.0	Electronic Comp onents SMT	Not allow missing parts, solderless connection, cold solder joint, mis match, The positive and negative polarity opposite				
5.0	Display color& B rightness	1. Color: Measuring the color coordinates, The measurement standar d according to the datasheet or samples. 2. Brightness: Measuring the brightness of White screen, The measu rement standard according to the datasheet or Samples.				
6.0	LCD Mura	By 5% ND filter invisible.				

7.0	RTP Related	TP film bubble/ accidented spot	Size $\Phi$ (mm)	Acceptable Qty		
				A	B	C
			$\Phi \leq 0.1$	Ignore		
			$0.1 < \Phi \leq 0.2$	3 (distance $\geq 10$ mm)		
			$0.25 < \Phi \leq 0.3$	2		
		$\Phi > 0.35$	0			
				Ignore		

			<table border="1"> <thead> <tr> <th rowspan="2">Width(mm)</th> <th rowspan="2">Length(mm)</th> <th colspan="3">Acceptable Qty</th> </tr> <tr> <th>A</th> <th>B</th> <th>C</th> </tr> </thead> <tbody> <tr> <td><math>\Phi \leq 0.05</math></td> <td>Ignore</td> <td colspan="2">Ignore</td> <td rowspan="3">Ignore</td> </tr> <tr> <td><math>0.05 &lt; W \leq 0.06</math></td> <td><math>L \leq 3.0</math></td> <td colspan="2"><math>N \leq 2</math></td> </tr> <tr> <td><math>0.07 &lt; W \leq 0.08</math></td> <td><math>L \leq 2.0</math></td> <td colspan="2"><math>N \leq 1</math></td> </tr> <tr> <td><math>0.08 &lt; W</math></td> <td colspan="4">Define as spot defect</td> </tr> </tbody> </table>	Width(mm)	Length(mm)	Acceptable Qty			A	B	C	$\Phi \leq 0.05$	Ignore	Ignore		Ignore	$0.05 < W \leq 0.06$	$L \leq 3.0$	$N \leq 2$		$0.07 < W \leq 0.08$	$L \leq 2.0$	$N \leq 1$		$0.08 < W$	Define as spot defect			
Width(mm)	Length(mm)	Acceptable Qty																											
		A	B	C																									
$\Phi \leq 0.05$	Ignore	Ignore		Ignore																									
$0.05 < W \leq 0.06$	$L \leq 3.0$	$N \leq 2$																											
$0.07 < W \leq 0.08$	$L \leq 2.0$	$N \leq 1$																											
$0.08 < W$	Define as spot defect																												
		Assembly deflection	beyond the edge of backlight $\leq 0.2\text{mm}$																										
		Bulge (undulation included)	<p>The ITO film plumped below 0.40mm, it's ok.</p> 																										
		Newton Ring	<p>Newton Ring area <math>&gt; 1/3</math> TP area NG</p> <p>Newton Ring area <math>\leq 1/3</math> TP area OK</p> 																										

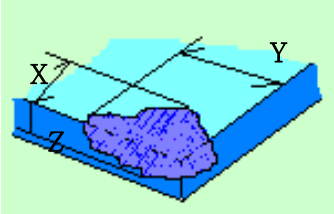
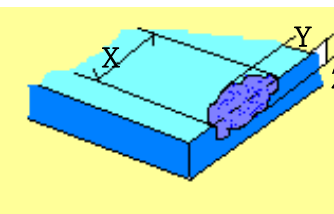
		TP corner broken X : length Y : width Z : height	<table border="1"> <tr> <td>X</td> <td>Y</td> <td>Z</td> </tr> <tr> <td>X≤3mm</td> <td>Y≤3mm</td> <td>Z&lt;COVER thickness s</td> </tr> </table> <p>*Circuitry broken is not allowed.</p>	X	Y	Z	X≤3mm	Y≤3mm	Z<COVER thickness s	
		X	Y	Z						
X≤3mm	Y≤3mm	Z<COVER thickness s								
TP edge broken X : length Y : width Z : height	<table border="1"> <tr> <td>X</td> <td>Y</td> <td>Z</td> </tr> <tr> <td>X≤4mm</td> <td>Y≤2mm</td> <td>Z&lt;COVER thickness</td> </tr> </table> <p>* Circuitry broken is not allowed.</p>	X	Y	Z	X≤4mm	Y≤2mm	Z<COVER thickness			
X	Y	Z								
X≤4mm	Y≤2mm	Z<COVER thickness								

Criteria ( functional items)

Number	Items	Criteria (mm)
1	No display	Not allowed
2	Missing segment	Not allowed
3	Short	Not allowed
4	Backlight no lighting	Not allowed
5	TP no function	Not allowed



## 8. Reliability Test Result

Item	Condition	Inspection after test
High Temperature Operating	70°C,96H	Inspection after 2~4hours storage at room temperature, the sample shall be free from defects: 1.Air bubble in the LCD; 2.Non-display; 3.Missing segments/line; 4.Glass crack; 5.Current IDD is twice higher than initial value.
Low Temperature Operating	-20°C, 96HR	
High Temperature Storage	80°C, 96HR	
Low Temperature Storage	-30°C, 96HR	
High Temperature & High Humidity Operating	+60°C, 90% RH ,96 hours.	
Thermal Shock (Non-operation)	-30°C,30 min ↔ +80°C,30 min, Change time:5min 20CYC.	
ESD test	C=150pF, R=330,5points/panel Air:±8KV, 5times; Contact:±6KV, 5 times; (Environment: 15°C~35°C, 30%~60%).	
Vibration (Non-operation)	Frequency range:10~55Hz, Stroke:1.5mm Sweep:10Hz~55Hz~10Hz 2 hours for each direction of X.Y.Z. (6 hours for total) (Package condition).	
Box Drop Test	1 Corner 3 Edges 6 faces,80cm(MEDIUM BOX)	

Remark:

- 1.The test samples should be applied to only one test item.
- 2.Sample size for each test item is 5~10pcs.
- 3.For Damp Proof Test, Pure water(Resistance > 10MΩ) should be used.
- 4.In case of malfunction defect caused by ESD damage, if it would be recovered to normal state after resetting, it would be judged as a good part.
- 5.Failure Judgment Criterion: Basic Specification, Electrical Characteristic, Mechanical Characteristic, Optical Characteristic.

Part. No	KD035VGFP A094	REV	V1.1	Page 25 of 27
	常备库存 Stock For Sale	长期供货 Long Time supply	支持小量 NO MOQ	品种齐全 In Full Range

## 9. Cautions and Handling Precautions

### 9.1 Handling and Operating the Module

- (1) When the module is assembled, it should be attached to the system firmly.  
Do not warp or twist the module during assembly work.
- (2) Protect the module from physical shock or any force. In addition to damage, this may cause improper operation or damage to the module and back-light unit.
- (3) Note that polarizer is very fragile and could be easily damaged. Do not press or scratch the surface.
- (4) Do not allow drops of water or chemicals to remain on the display surface.  
If you have the droplets for a long time, staining and discoloration may occur.
- (5) If the surface of the polarizer is dirty, clean it using some absorbent cotton or soft cloth.
- (6) The desirable cleaners are water, IPA (Isopropyl Alcohol) or Hexane.  
Do not use ketene type materials (ex. Acetone), Ethyl alcohol, Toluene, Ethyl acid or Methyl chloride. It might permanent damage to the polarizer due to chemical reaction.
- (7) If the liquid crystal material leaks from the panel, it should be kept away from the eyes or mouth. In case of contact with hands, legs, or clothes, it must be washed away thoroughly with soap.
- (8) Protect the module from static; it may cause damage to the CMOS ICs.
- (9) Use finger-stalls with soft gloves in order to keep display clean during the incoming inspection and assembly process.
- (10) Do not disassemble the module.
- (11) Protection film for polarizer on the module shall be slowly peeled off just before use so that the electrostatic charge can be minimized.
- (12) Pins of I/F connector shall not be touched directly with bare hands.
- (13) Do not connect, disconnect the module in the "Power ON" condition.
- (14) Power supply should always be turned on/off by the item 6.1 Power On Sequence & 6.2 Power Off Sequence

### 9.2 Storage and Transportation.

- (1) Do not leave the panel in high temperature, and high humidity for a long time.  
It is highly recommended to store the module with temperature from 0 to 35 °C and relative humidity of less than 70%
- (2) Do not store the TFT-LCD module in direct sunlight.
- (3) The module shall be stored in a dark place. When storing the modules for a long time, be sure to adopt effective measures for protecting the modules from strong ultraviolet radiation, sunlight, or fluorescent light.
- (4) It is recommended that the modules should be stored under a condition where no condensation is allowed. Formation of dewdrops may cause an abnormal operation or a failure of the module.  
In particular, the greatest possible care should be taken to prevent any module from being operated where condensation has occurred inside.
- (5) This panel has its circuitry FPC on the bottom side and should be handled carefully in order not to be stressed.

Part. No	KD035VGFP A094	REV	V1.1	Page 26 of 27
常备库存 Stock For Sale	长期供货 Long Time supply	支持小量 NO MOQ	品种齐全 In Full Range	

## 10. Packing

----TBD-----

Part. No	KD035VGFP A094	REV	V1.1	Page 27 of 27
	常备库存 Stock For Sale	长期供货 Long Time supply	支持小量 NO MOQ	品种齐全 In Full Range