

## CYL49E Linear Hall Effect Sensors

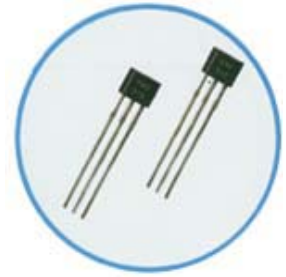

CYL49E linear Hall-effect integrated circuit based on Hall-effect principle, includes a voltage regulator, Hall-voltage generator, linear amplifier, and emitter-follower output stage. The output of the ICs changes linearly with the magnetic flux density of the input.

### FEATURES

- Small Size
- High Accuracy
- High Sensitivity
- Excellent Reliability
- Low Power

### TYPICAL APPLICATION

- Motion Detector
- Gear Tooth Sensors
- Proximity Detector
- Speed Regulator for Sports Appliance
- Current Detecting Sensor

### FUNCTIONAL BLOCK DIAGRAM

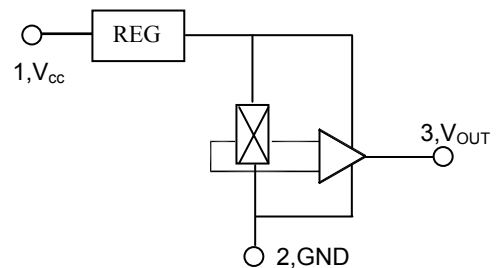

### ABSOLUTE MAXIMUM RATINGS

Parameter	Symbol	Value	Unit
Supply Voltage	V <sub>cc</sub>	9	V
Operating Temperature Range	T <sub>A</sub>	-40~85	°C
Storage Temperature Range	T <sub>S</sub>	-65~150	°C

### ELECTRICAL & MAGNETIC CHARACTERISTICS (T<sub>A</sub>=25°C, V<sub>cc</sub>=5.0V)

Supply current I <sub>cc</sub> (mA)	Output upper Limit Voltage V <sub>T</sub> (V) B≥90mT	Output Lower Limit Voltage V <sub>L</sub> (V) B≤-90mT	Quiescent Output Voltage V <sub>o</sub> (V) B=0mT	Sensitivity S (mV/mT)	Operating Temperature Range (°C)	Output Function
≤8mA	≥4.20	≤1	2.5±0.1	15~20	-40~+85	Linear

### Connection

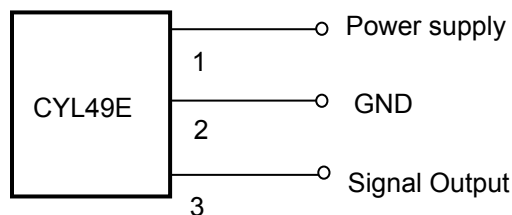

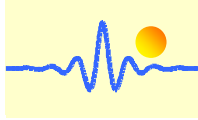

## Characteristics Curves

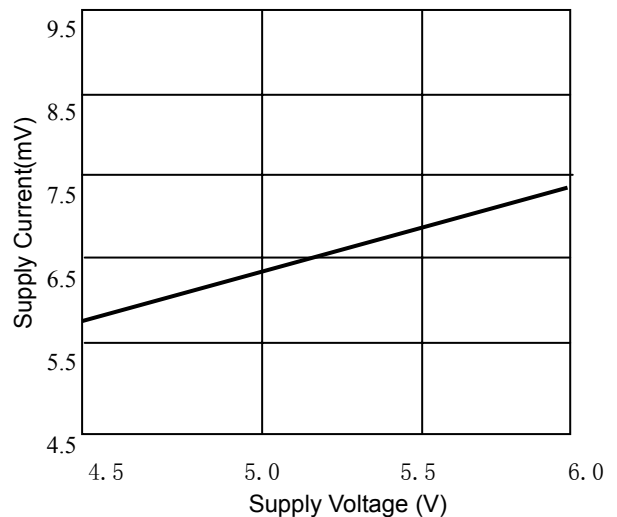
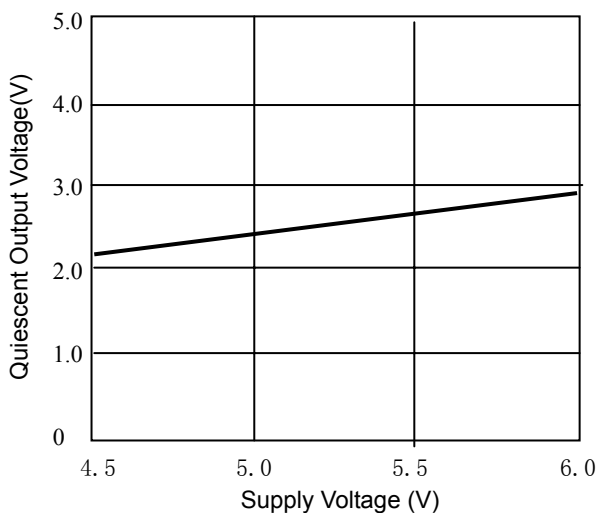
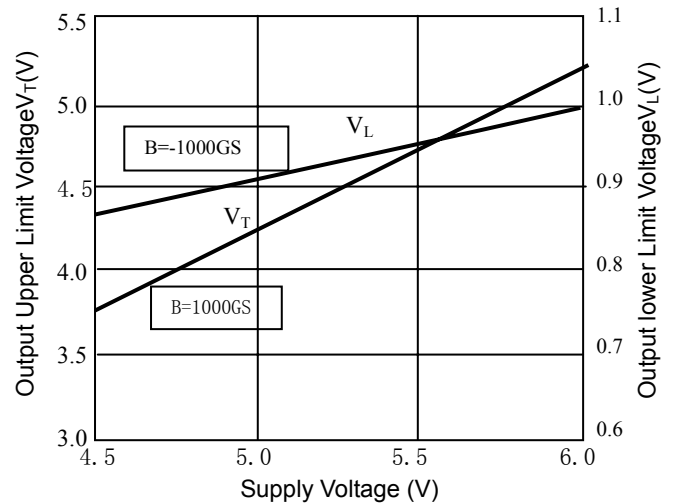
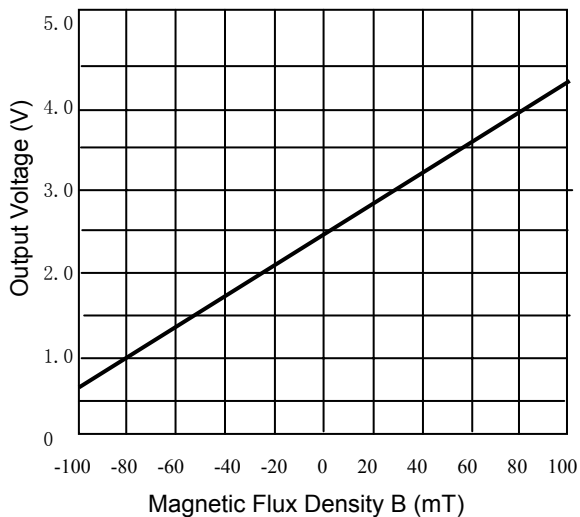

## Principles

The quiescent output voltage ( $B=0\text{mT}$ ) is nominally one-half the supply voltage. When a south magnetic pole presented to the branded face of the Hall-effect IC, it will drive the output higher than the quiescent voltage. A north magnetic pole will drive the output below the quiescent output voltage. In operation, instantaneous and proportional output voltage levels are dependent on magnetic flux density at the most sensitive area of the device. Improve the supply voltage can increase its sensitivity.

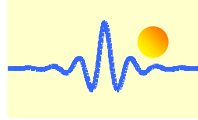

## Package (Unit: mm)

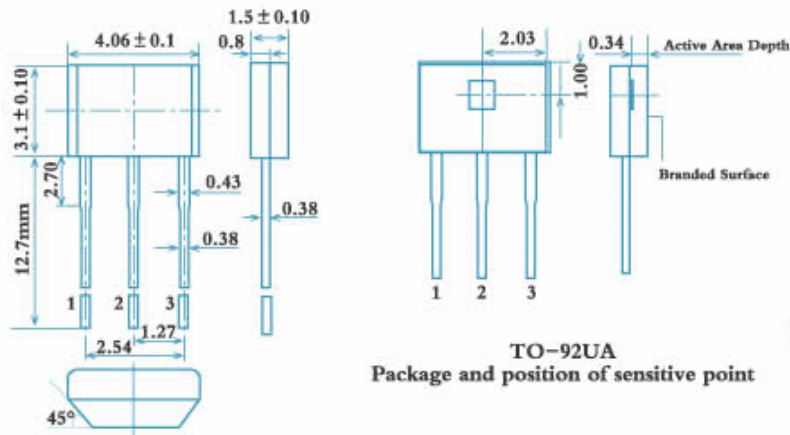

### PIN NOTES

1. Power Supply
2. Ground
3. Output

### CAUTIONS

- ◆ It is possible that outside mechanical stress affects the operating point and the release point of Hall-effect circuits, therefore, mechanical stress should be lessened as far as possible in the process of assembly;
- ◆ Pay attention to the soldering temperature at the leads, keep it lower in a short time to guarantee good soldering quality.

## Applications

### NOTCH SENSOR

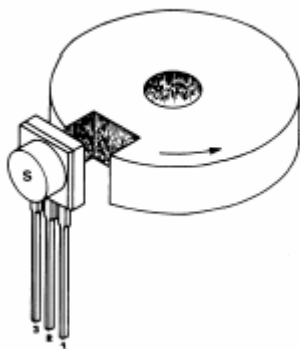

### GEAR TOOTH SENSOR

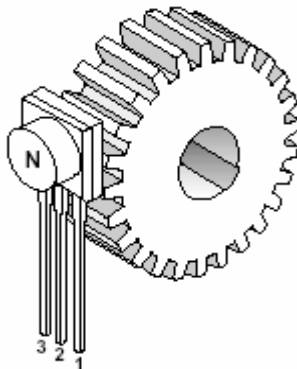

### CURRENT MONITOR

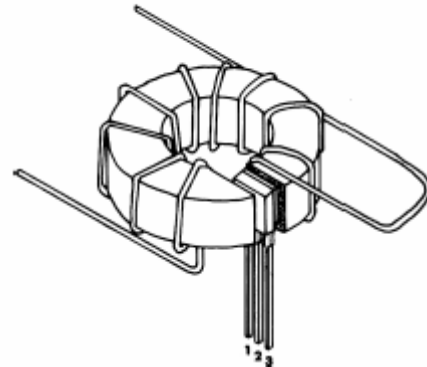

## Note:

- ◆ Mechanical Stress Should be lessened as far as possible in the process of assembly
- ◆ The soldering temperature at the leads should be less than 260°C with 5 seconds.
- ◆ If N pole is approaching hall-effect ICs from the back side of the package, output voltage will increase, S pole is approaching ICs from the back side, output voltage will reduce; and if from the branded side of the package, the output situation is just to the contrary.