

(((PaPIRs)))

**Panasonic**  
INDUSTRY



# PIR

## Motion Sensor

## Pyroelectric infrared motion sensors from Panasonic for optimal usability and reliability

Panasonic develops and produces PIR motion sensors, which combine easy integration, high reliability and environment-friendly materials.

The Panasonic PIR motion sensors abbreviated as PaPIRs, have different series of products, including:

### EKM PaPIRs: 3rd generation



EKMB (WL) digital output for battery-operated devices (1, 2, 6 $\mu$ A)  
 EKMC (VZ) digital and analog output for battery-free devices (170 $\mu$ A)  
 Available lens colors: white, black and pearl white

### AMN NaPiOn: 2nd generation



AMN3 digital output for battery-free devices (170 $\mu$ A)  
 Available lens colors: white and black

## Applications

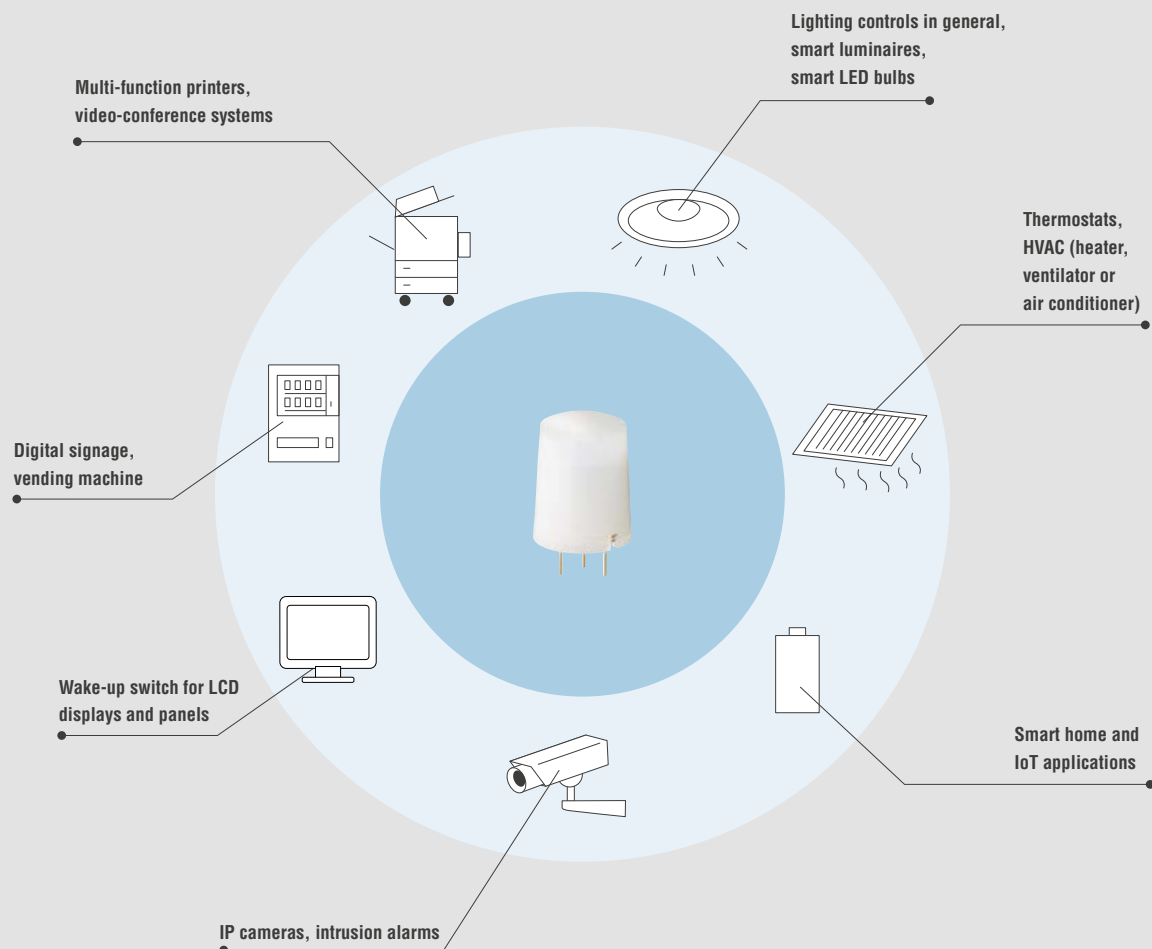

Introduction .....	2	EKM - Characteristics .....	16
Ordering Information .....	3	AMN - Standard Detection Type .....	18
PaPIRs design features .....	4	AMN - Slight Motion Detection Type .....	19
Technical information for all sensors (EKM and AMN) .....	6	AMN - Spot Detection Type .....	20
EKM - Standard Detection Type .....	7	AMN - 10m Detection Type (long distance) .....	21
EKM - Low Profile Type .....	8	AMN - Characteristics .....	22
EKM - Slight Motion Detection Type .....	9	Cautions for use .....	23
EKM - Standard and Slight Motion Detection Type .....	10		
EKM - High Density Long Distance Detection Type .....	11		
EKM - Horizontally Wide Detection Type .....	12		
EKM - Wall Installation Detection Type (corner) .....	13		
EKM - Long Distance Detection Type .....	14		
EKM - Lensless Type .....	15		

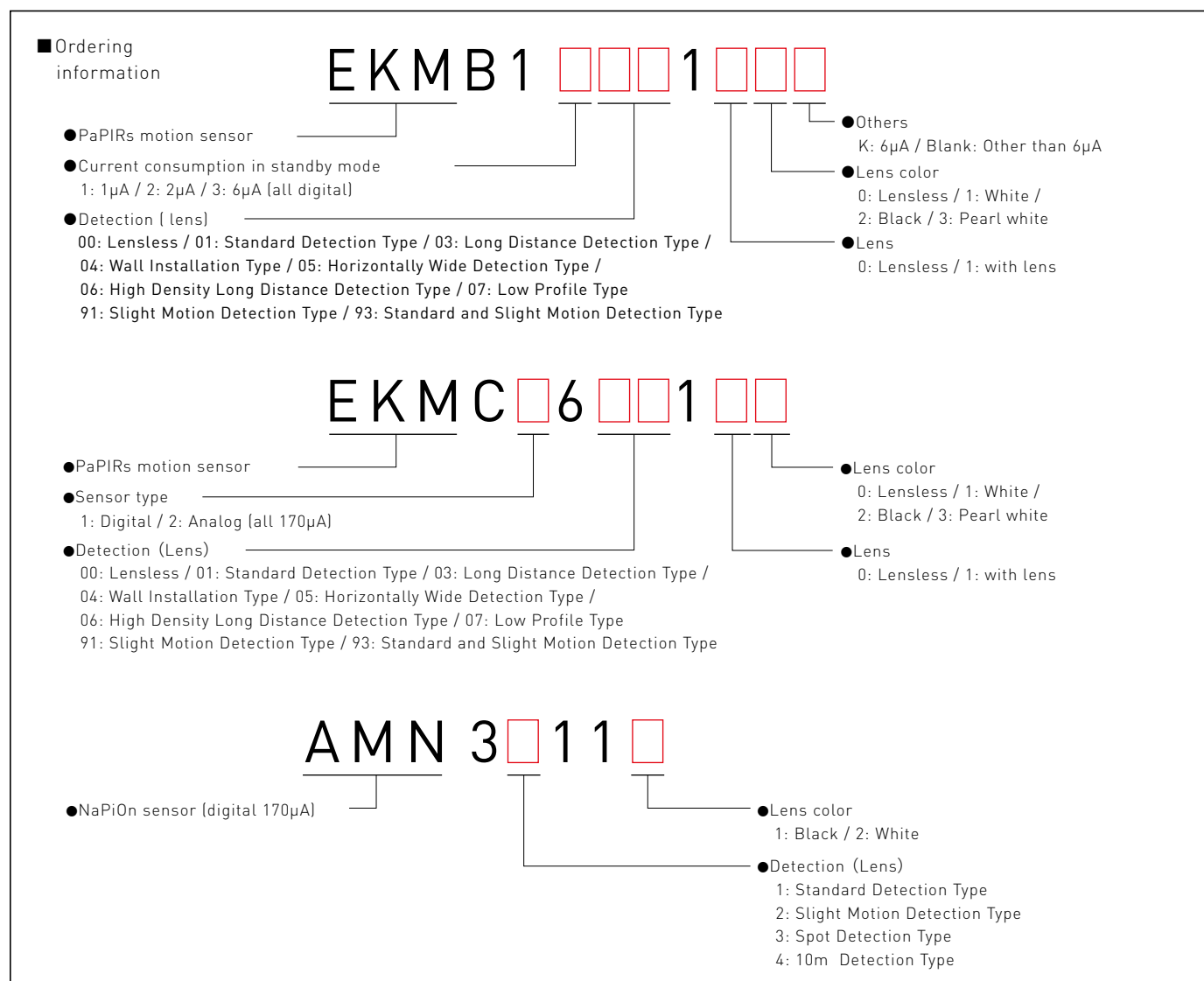

## PaPIRs design features

The PIR motion sensors from Panasonic offer crucial advantages over conventional PIR motion sensors. The unique design concept (explained below) ranges from the production of the pyroelectric sensing devices to the internal signal processing, thus guaranteeing an optimal detection capability and high reliability.

### Easy design-in

The integrated amplifier/comparator circuit inside a TO-5 metal can (digital type) prevents interferences caused by electromagnetic fields, such as those generated by cell phones and wireless devices. A special differential circuit design is introduced for the EKMB 6 $\mu$ A type for applications where a high noise resistance is required (up to GHz range).

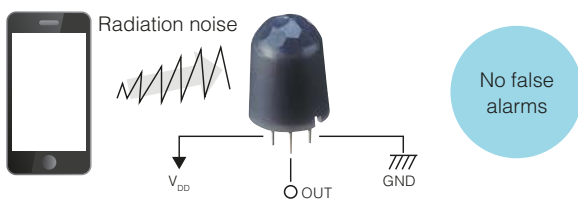
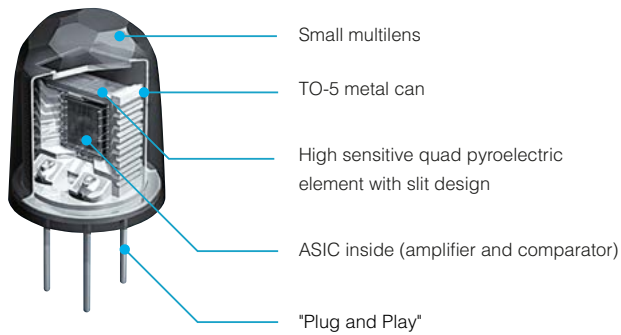

### Small and fancy lens design

Thanks to the special design of the small pyroelectric elements, it is possible to use a smaller lens size while keeping the same detection area and distance compared to conventional sensors.

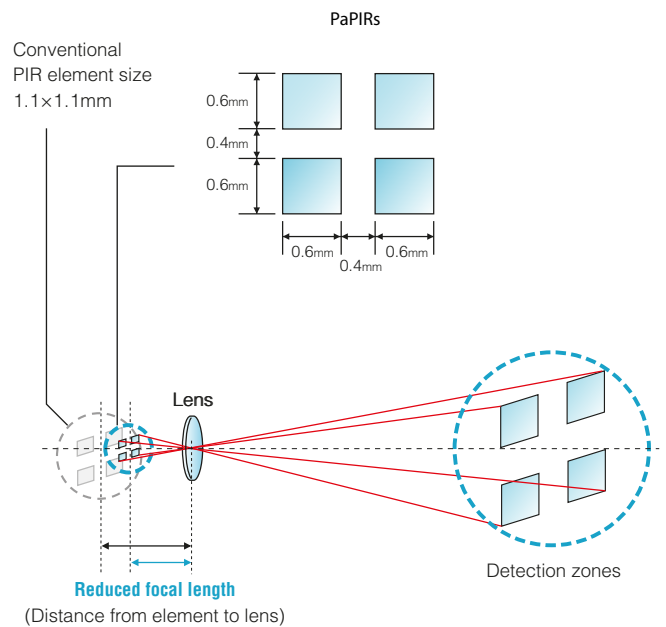

Two times better sensitivity

The sensitivity has been significantly improved thanks to a unique slit design of the pyroelectric elements. The separated sensing areas prevent thermal crosstalk between the single sensing elements. Therefore, reliable detection is possible even if the temperature difference between the background (e.g. floor / wall) and the target object (human) is small. (e.g.  $\Delta T = 4^{\circ}\text{C}$ )

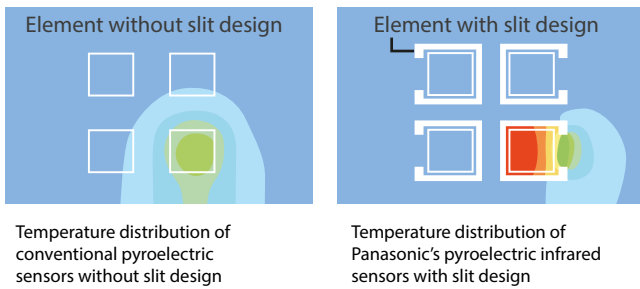

Four times better signal-to-noise ratio

Improved signal-to-noise ratio thanks to a special I/V circuit which is used for converting a current signal from the pyroelectric element to voltage. Panasonic PIR motion sensors perform by the feedback capacitor and the operational amplifier, different from the conventional FET-type, thereby decreasing the probability of false alarms due to temperature fluctuation.

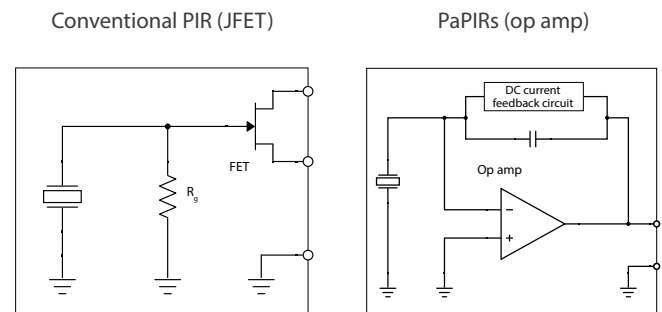

Lead-free pyroelectric element

A ferroelectric Lithiumtantalate ( $\text{LiTaO}_3$ ) single lead-free crystal is used as the pyroelectric element for Panasonic PIR motion sensors. Conventional PIR motion sensors normally use a ceramic base material (e.g. PZT) for the pyroelectric element, which contains lead in many cases.

Low current consumption EKMB (WL)

Reduction of current consumption (1, 2 or  $6\mu\text{A}$ ) thanks to the special circuit design technology allows battery life to be extended for battery-driven products.

PaPIRs: High signal-to-noise ratio

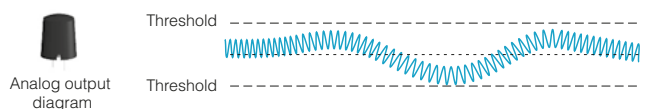

Conventional types: Low signal-to-noise ratio

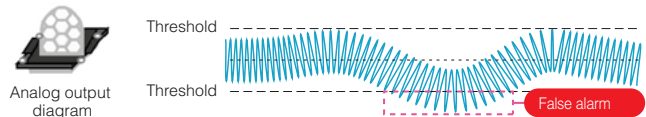

## Technical information for all sensors (EKM and AMN)

## Block diagram output circuit

## Digital output with integrated amplifier and comparator

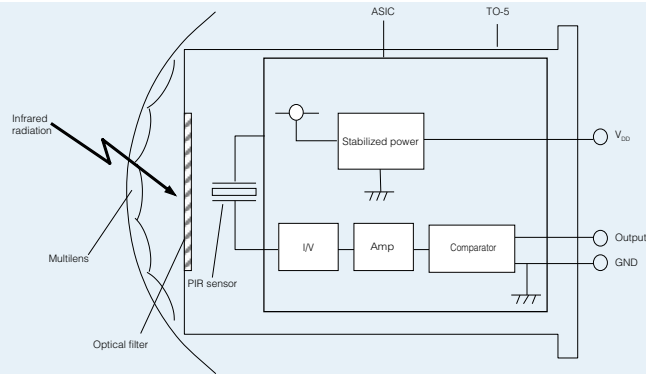

## Analog output with integrated amplifier

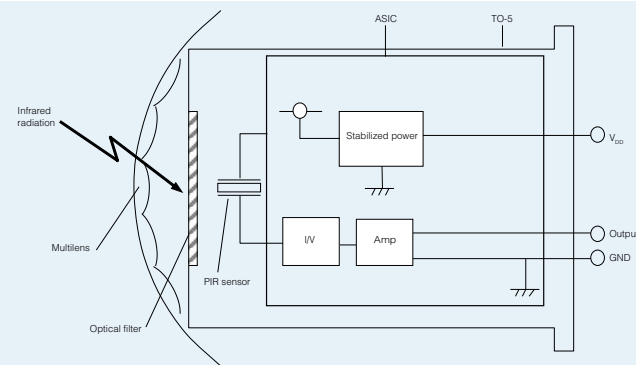

## Wiring diagram

## Digital output

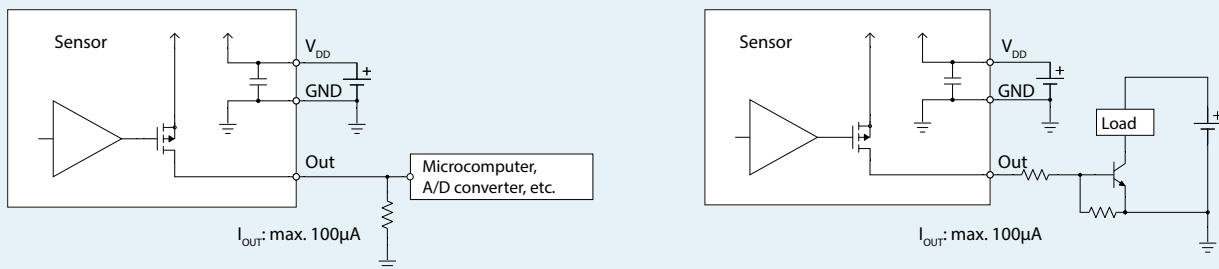

## Analog output

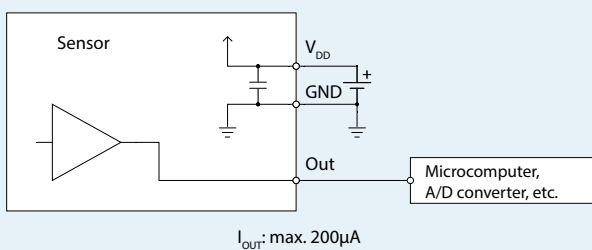

**IMPORTANT:**  
The analog types are not temperature compensated.  
Please contact us for further information and design-in support.

## Notes: Digital output types:

The output signal for the digital output type is from inside FET drain, therefore pull-down resistors are necessary. Please select an output resistor (pull-down concept) in accordance with  $V_{OUT}$  so that the output current is maximum 100 $\mu$ A. If the output current is more than 100 $\mu$ A, this may cause false alarms.

If the microcomputer has a pull-down function, there is no need for a resistor as long as the output current does not exceed 100 $\mu$ A.

## Analog output types (EKM26 series):

In either case, a microcomputer or a resistor needs to be chosen in accordance to  $V_{OUT}$  so that the output current is maximum 200 $\mu$ A.

### EKM - Standard Detection Type



Preference type  
 Flat lens for an unobtrusive integration  
 Lens diameter 9.5mm

Specified detection distance (Note 1)	up to 5m
Typical ceiling installation height (Note 2)	3m
Field of view	106° x 97°
Detection zones	64
Note 1: > $\Delta T \geq 4^{\circ}C$ > Object speed: 1m/s > Object size: 700 x 250mm > Crossing 2 detection zones	Note 2: The sensitivity of passive infrared sensors is influenced by environmental conditions, so a performance evaluation test under representative conditions is recommended

#### Typical applications

- > Lighting controls for offices and smart homes
- > Smart luminaires
- > Smart LED bulbs
- > Ventilation systems and air conditioners
- > IP cameras
- > Digital signage
- > Wake-up switch for displays

Further information on electrical characteristics please see page 16

#### Dimension (in mm, inches in brackets)

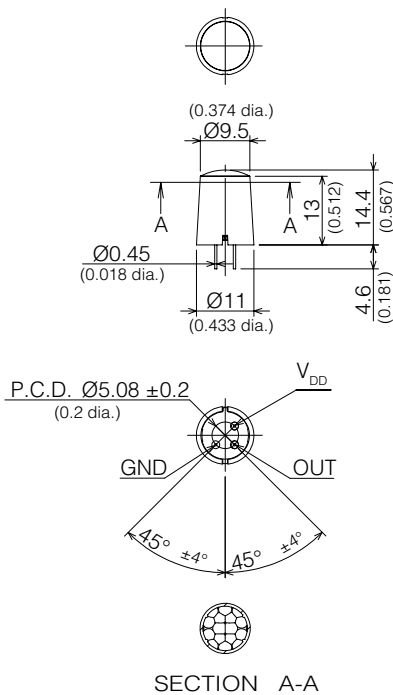

#### Detection area

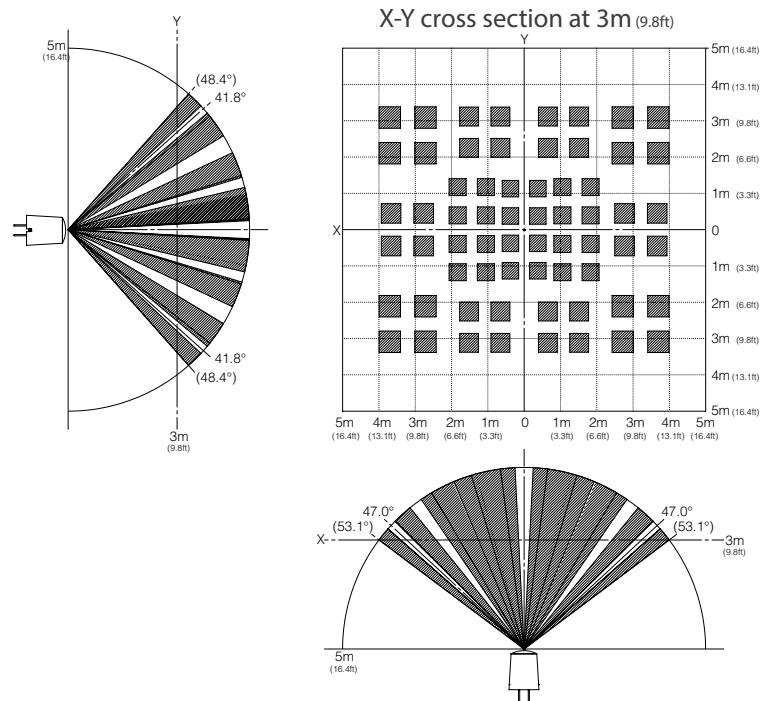

Notes	Standby current consumption	Output type	Sensitivity	White	Black	Pearl White
High-end	1μA	Digital (open drain)	Standard	EKMB1101111	EKMB1101112	EKMB1101113
	2μA	Digital (open drain)	Standard	EKMB1201111	EKMB1201112	EKMB1201113
Economy	6μA	Digital (open drain)	Standard	EKMB1301111K	EKMB1301112K	EKMB1301113K
	170μA	Digital (open drain)	Standard	EKMC1601111	EKMC1601112	EKMC1601113
	170μA	Analog (op amp)	Adjustable	EKMC2601111K	EKMC2601112K	EKMC2601113K
Special	6μA	Digital (open drain)	High	Please contact us if a higher or a lower sensitivity is required.		
	170μA	Digital (open drain)	High			
	170μA	Digital (open drain)	Low			

Note: The specification shows the X-Y cross section at 2.5m.

Further information at [www3.panasonic.biz/ac/e/control/sensor/human/index.jsp](http://www3.panasonic.biz/ac/e/control/sensor/human/index.jsp)



## EKM - Low Profile Type



Low height sensor (10.9mm)

Flat lens

Lip for mechanical stop or for an O-ring

Specified detection distance (Note 1)	up to 5m
Typical ceiling installation height (Note 2)	3m
Field of view	110° x 110°
Detection zones	32
Note 1: > ΔT ≥ 4°C > Object speed: 1m/s > Object size: 700 x 250mm > Crossing 2 detection zones	Note 2: The sensitivity of passive infrared sensors is influenced by environmental conditions, so a performance evaluation test under representative conditions is recommended

### Typical applications

- > LED screen for TV, PC
- > Wake-up switch for displays
- > Digital signage
- > Lighting controls for offices and smart home
- > Smart luminaires
- > Ventilation systems and air conditioners
- > IP cameras

Further information on electrical characteristics please see page 16

### Dimension (in mm, inches in brackets)

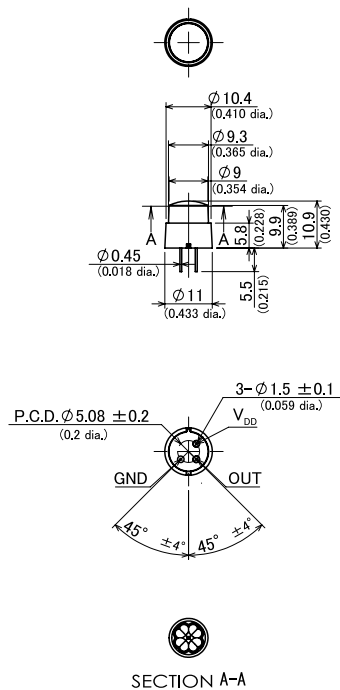

### Detection area

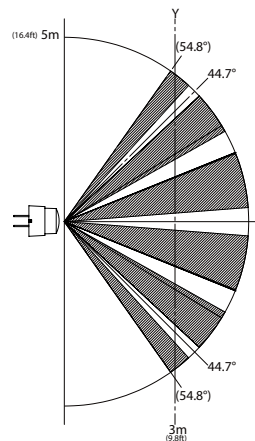

### X-Y cross section at 3m (9.8ft)

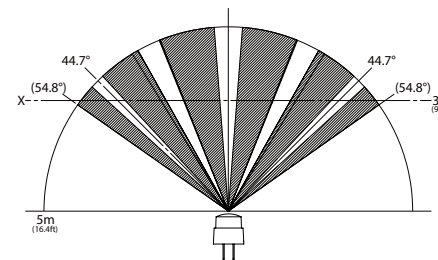
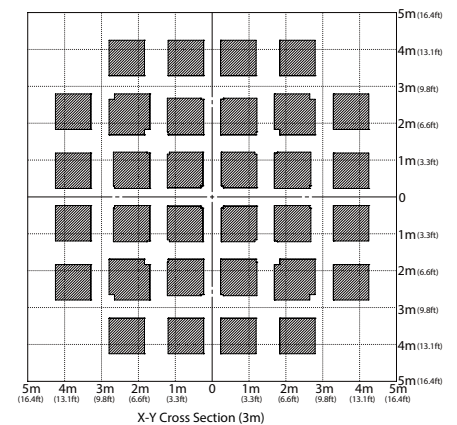

Notes	Standby current consumption	Output type	Sensitivity	White	Black	Pearl White
High-end	1μA	Digital (open drain)	Standard	EKMB1107111	EKMB1107112	EKMB1107113
	2μA	Digital (open drain)	Standard	EKMB1207111	EKMB1207112	EKMB1207113
Economy	6μA	Digital (open drain)	Standard	EKMB1307111K	EKMB1307112K	EKMB1307113K
	170μA	Digital (open drain)	Standard	EKMC1607111	EKMC1607112	EKMC1607113
	170μA	Analog (op amp)	Adjustable	EKMC2607111K	EKMC2607112K	EKMC2607113K
Special	6μA	Digital (open drain)	High	Please contact us if a higher or a lower sensitivity is required.		
	170μA	Digital (open drain)	High			
	170μA	Digital (open drain)	Low			

Note: The specification shows the X-Y cross section at 2.5m.

Further information at [www3.panasonic.biz/ac/e/control/sensor/human/index.jsp](http://www3.panasonic.biz/ac/e/control/sensor/human/index.jsp)



## EKM - Slight Motion Detection Type



Optimized for small movements

Lens diameter 14.6mm

Almost the same mechanical dimensions like the Standard and Slight Motion Detection Type (lens diameter 0.3mm smaller)

Specified detection distance (Note 1)	up to 2.5m - 4m
Typical ceiling installation height (Note 2)	3m
Field of view	104° x 104°
Detection zones	112
<b>Note 1:</b> > ΔT ≥ 4°C > Object speed: 0.5m/s > Object size: 200 x 200mm > Crossing 1 detection zone	<b>Note 2:</b> The sensitivity of passive infrared sensors is influenced by environmental conditions, so a performance evaluation test under representative conditions is recommended

### Typical applications

- › Lighting controls for offices and smart homes
- › Smart luminaires
- › Smart LED bulbs
- › Ventilation systems and air conditioners

Further information on electrical characteristics please see page 16

### Dimension (in mm, inches in brackets)

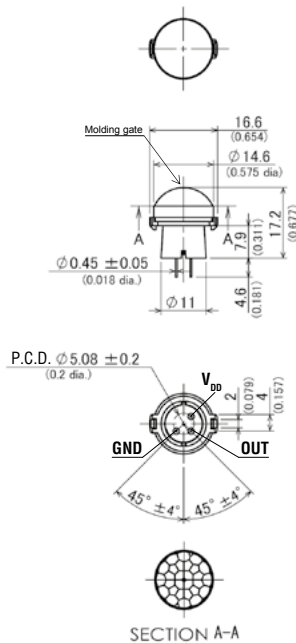

### Detection area

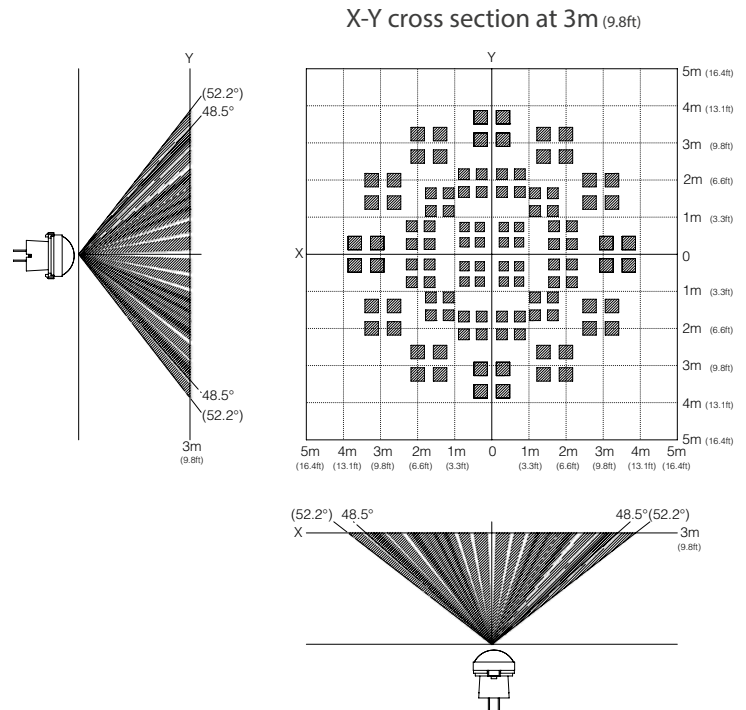

Notes	Standby current consumption	Output type	Sensitivity	White	Black	Pearl White
High-end	1μA	Digital (open drain)	Standard	EKMB1191111	EKMB1191112	EKMB1191113
	2μA	Digital (open drain)	Standard	EKMB1291111	EKMB1291112	EKMB1291113
Economy	6μA	Digital (open drain)	Standard	EKMB1391111K	EKMB1391112K	EKMB1391113K
	170μA	Digital (open drain)	Standard	EKMC1691111	EKMC1691112	EKMC1691113
	170μA	Analog (op amp)	Adjustable	EKMC2691111K	EKMC2691112K	EKMC2691113K
Special	6μA	Digital (open drain)	High	Please contact us if a higher or a lower sensitivity is required.		
	170μA	Digital (open drain)	High			
	170μA	Digital (open drain)	Low			

Note: The specification shows the X-Y cross section at 2.5m.

Further information at [www3.panasonic.biz/ac/e/control/sensor/human/index.jsp](http://www3.panasonic.biz/ac/e/control/sensor/human/index.jsp)

## EKM - Standard and Slight Motion Detection Type



The rectangular center zone is optimized detecting smallest movements.

Lens diameter 14.9mm

Almost the same mechanical dimensions like the Slight Motion Detection Type (lens diameter 0.3mm bigger)

Specified detection distance (Note 1)	up to 2.2m - 3.1m
Typical ceiling installation height (Note 2)	3m
Field of view slight motion area	44° x 44°
Field of view standard motion area	91° x 91°
Detection zones slight motion area	36
Detection zones standard motion area	48
Note 1: > ΔT ≥ 4°C > Object speed: 0.5m/s (slight motion area) > Object speed: 1m/s (standard motion area) > Object size: 200 x 200mm (slight motion area) > Object size: 400 x 200mm (standard motion area) > Crossing 1 detection zone (slight motion area) > Crossing 2 detection zones (standard motion area)	Note 2: The sensitivity of passive infrared sensors is influenced by environmental conditions, so a performance evaluation test under representative conditions is recommended

Further information on electrical characteristics please see page 16

### Typical applications

- > Lighting controls for restrooms, changing rooms, smoking cabins and hotel rooms
- > Smart luminaires
- > Smart LED bulbs
- > Ventilation systems and air conditioners
- > Hot desking
- > Digital signage
- > Vending machines
- > Wake-up switch for displays

### Dimension (in mm, inches in brackets)

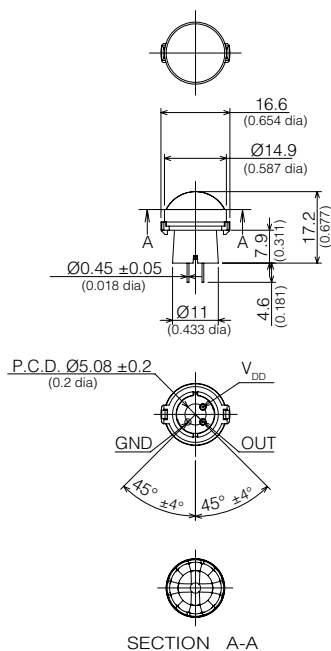

### Detection area

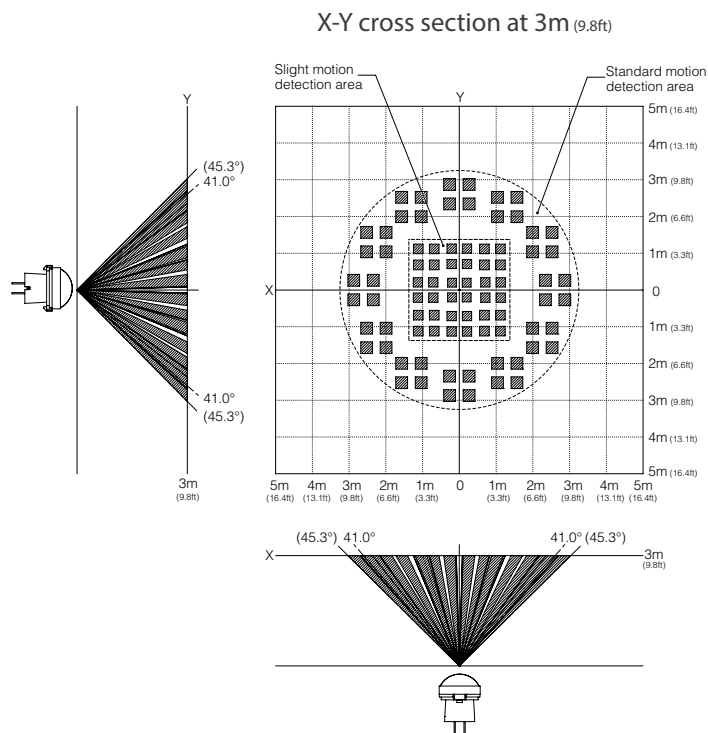

Notes	Standby current consumption	Output type	Sensitivity	White	Black	Pearl White
High-end	1µA	Digital (open drain)	Standard	EKMB1193111	EKMB1193112	EKMB1193113
	2µA	Digital (open drain)	Standard	EKMB1293111	EKMB1293112	EKMB1293113
Economy	6µA	Digital (open drain)	Standard	EKMB1393111K	EKMB1393112K	EKMB1393113K
	170µA	Digital (open drain)	Standard	EKMC1693111	EKMC1693112	EKMC1693113
	170µA	Analog (op amp)	Adjustable	EKMC2693111K	EKMC2693112K	EKMC2693113K
Special	6µA	Digital (open drain)	High	Please contact us if a higher or a lower sensitivity is required.		
	170µA	Digital (open drain)	High			
	170µA	Digital (open drain)	Low			

Note: The specification shows the X-Y cross section at 2.2m.

Further information at [www3.panasonic.biz/ac/e/control/sensor/human/index.jsp](http://www3.panasonic.biz/ac/e/control/sensor/human/index.jsp)

## EKM - High Density Long Distance Detection Type



Smallest long range sensor  
 Maximum installation height of 17m (high sensitivity type)  
 Lens diameter 19.3mm  
 Lip for mechanical stop or for an O-ring

Maximum installation height of 17m

Specified detection distance (Note 1)	up to 12m - 14.5m
Typical ceiling installation height (Note 2)	12m
Field of view	69° x 69°
Detection zones	128
Note 1: > ΔT ≥ 4°C > Object speed: 1m/s > Object size: 700 x 250mm > Crossing 2 detection zones	Note 2: The sensitivity of passive infrared sensors is influenced by environmental conditions, so a performance evaluation test under representative conditions is recommended

### Typical applications

- Lighting controls for warehouses, industrial buildings, entrance halls and retail shops
- Smart high-bay luminaires
- Street lighting
- Security cameras

Further information on electrical characteristics please see page 16

### Dimension (in mm, inches in brackets)

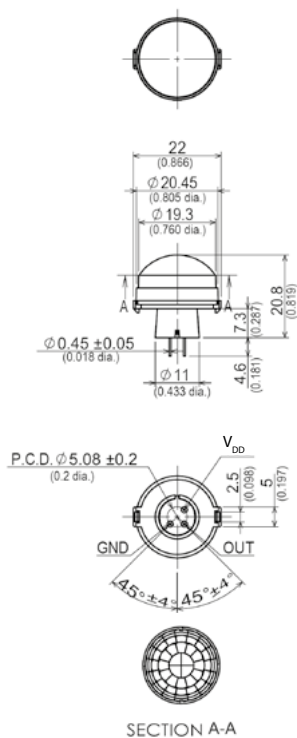

### Detection area

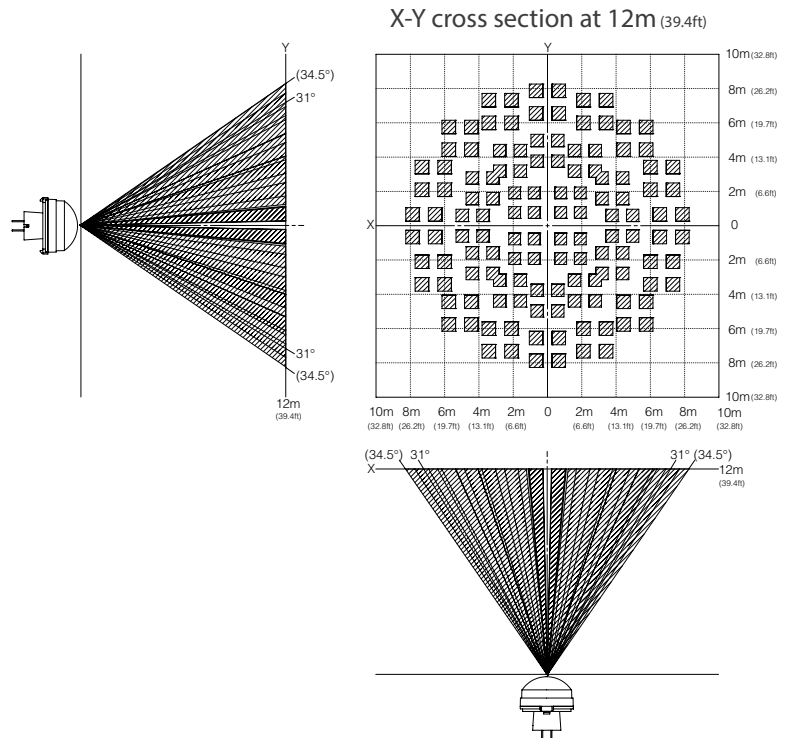

Notes	Standby current consumption	Output type	Sensitivity	White	Black	Pearl White
High-end	1μA	Digital (open drain)	Standard	EKMB1106111	EKMB1106112	EKMB1106113
	2μA	Digital (open drain)	Standard	EKMB1206111	EKMB1206112	EKMB1206113
Economy	6μA	Digital (open drain)	Standard	EKMB1306111K	EKMB1306112K	EKMB1306113K
	170μA	Digital (open drain)	Standard	EKMC1606111	EKMC1606112	EKMC1606113
Special	170μA	Analog (op amp)	Adjustable	EKMC2606111K	EKMC2606112K	EKMC2606113K
	6μA	Digital (open drain)	High	Please contact us if a higher or a lower sensitivity is required.		
	170μA	Digital (open drain)	High			
170μA	Digital (open drain)	Low				

### EKM - Horizontally Wide Detection Type



World's first PIR with "Approach Sensing" technology  
Panasonic presents the world's first PIR sensor in the shape of a hammerhead with a special optic, which is more sensitive to radial motion.

Specified detection distance (Note 1 & 2)	up to 5m
Field of view area A	122° x 35°
Field of view area B	150° x 20°
Detection zones area A	88
Detection zones area B	16
Note 1: > ΔT ≥ 4°C (Area A) > ΔT ≥ 8°C (Area B) > Object speed: 1m/s > Object size: 700 x 250mm > Crossing 2 detection zones	Note 2: The sensitivity of passive infrared sensors is influenced by environmental conditions, so a performance evaluation test under representative conditions is recommended

Further information on electrical characteristics please see page 16

#### Typical applications

- > Corridor sensors
- > Wall switches
- > Thermostats
- > Intrusion alarm sensors for windows and doors
- > Door intercom systems
- > Entrance and garden lamps
- > Wake-up switch for displays

#### Dimension (in mm, inches in brackets)

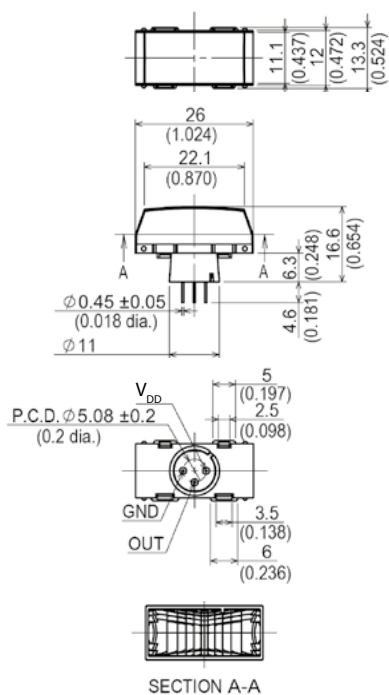

#### Detection area

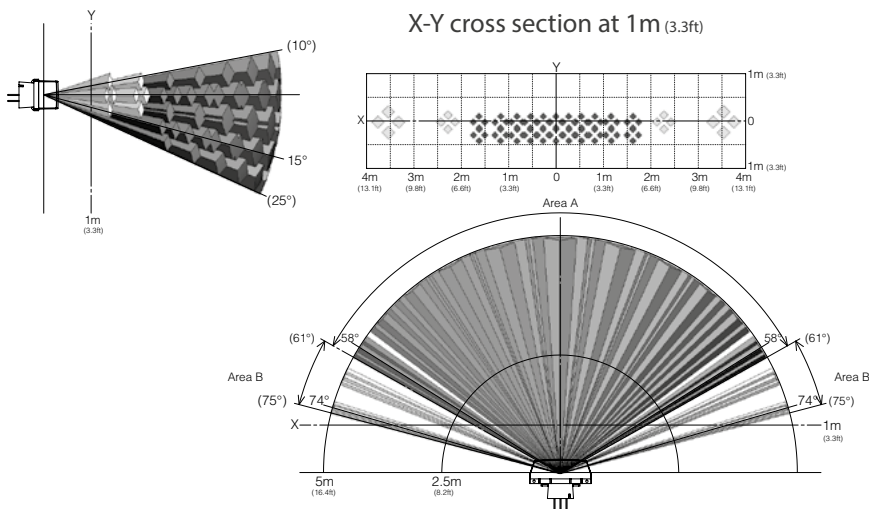

Notes	Standby current consumption	Output type	Sensitivity	White	Black	Pearl White
High-end	1μA	Digital (open drain)	Standard	EKMB1105111	EKMB1105112	EKMB1105113
	2μA	Digital (open drain)	Standard	EKMB1205111	EKMB1205112	EKMB1205113
Economy	6μA	Digital (open drain)	Standard	EKMB1305111K	EKMB1305112K	EKMB1305113K
	170μA	Digital (open drain)	Standard	EKMC1605111	EKMC1605112	EKMC1605113
Special	170μA	Analog (op amp)	Adjustable	EKMC2605111K	EKMC2605112K	EKMC2605113K
	6μA	Digital (open drain)	High	Please contact us if a higher or a lower sensitivity is required.		
	170μA	Digital (open drain)	High			
170μA	Digital (open drain)	Low				

### EKM - Wall Installation Detection Type (corner)



Lens diameter 20.7mm

Similar dimensions like the Long Distance Detection Type

Specified detection distance (Note 1 & 2)	up to 12m (1st step lens) up to 6m (2nd step lens) up to 3m (3rd step lens)
Field of view	56° x 112°
Detection zones	68
Note 1: > ΔT ≥ 4°C > Object speed: 1m/s > Object size: 700 x 250mm > Crossing 2 detection zones	Note 2: The sensitivity of passive infrared sensors is influenced by environmental conditions, so a performance evaluation test under representative conditions is recommended

#### Typical applications

- > Intrusion alarm sensors
- > Thermostats
- > Door intercom systems
- > Entrance and garden lamps

Further information on electrical characteristics please see page 16

#### Dimension (in mm, inches in brackets)

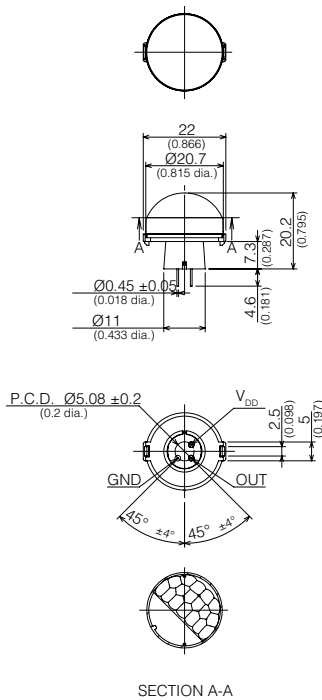

#### Detection area

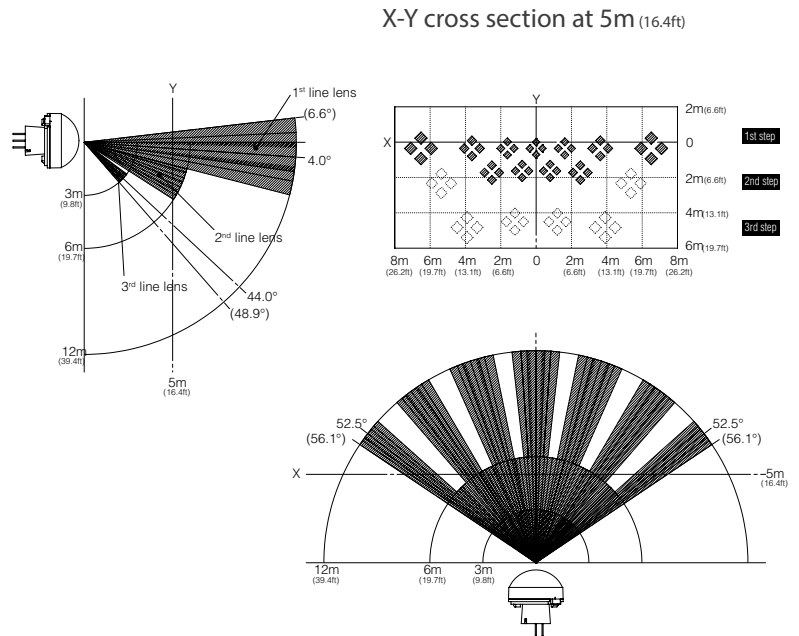

Notes	Standby current consumption	Output type	Sensitivity	White	Black	Pearl White
High-end	1μA	Digital (open drain)	Standard	EKMB1104111	EKMB1104112	EKMB1104113
	2μA	Digital (open drain)	Standard	EKMB1204111	EKMB1204112	EKMB1204113
Economy	6μA	Digital (open drain)	Standard	EKMB1304111K	EKMB1304112K	EKMB1304113K
	170μA	Digital (open drain)	Standard	EKMC1604111	EKMC1604112	EKMC1604113
Special	170μA	Analog (op amp)	Adjustable	EKMC2604111K	EKMC2604112K	EKMC2604113K
	6μA	Digital (open drain)	High	Please contact us if a higher or a lower sensitivity is required.		
	170μA	Digital (open drain)	High			
170μA	Digital (open drain)	Low				

### EKM - Long Distance Detection Type



Lens diameter 20.7mm

Similar dimensions like the Wall Installation Type

Specified detection distance (Note 1)	up to 12m
Typical ceiling installation height (Note 2)	7m
Field of view	108° x 99°
Detection zones	92
<b>Note 1:</b> > ΔT ≥ 4°C > Object speed: 1m/s > Object size: 700 x 250mm > Crossing 2 detection zones	<b>Note 2:</b> The sensitivity of passive infrared sensors is influenced by environmental conditions, so a performance evaluation test under representative conditions is recommended

#### Typical applications

- > Lighting control for sport halls and public areas
- > Intrusion alarm sensors
- > Street lighting
- > Security cameras

Further information on electrical characteristics please see page 16

#### Dimension (in mm, inches in brackets)

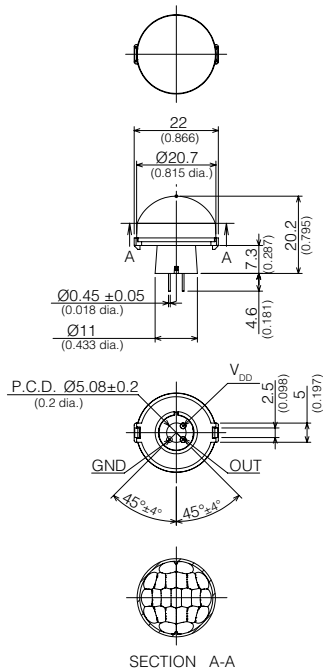

#### Detection area

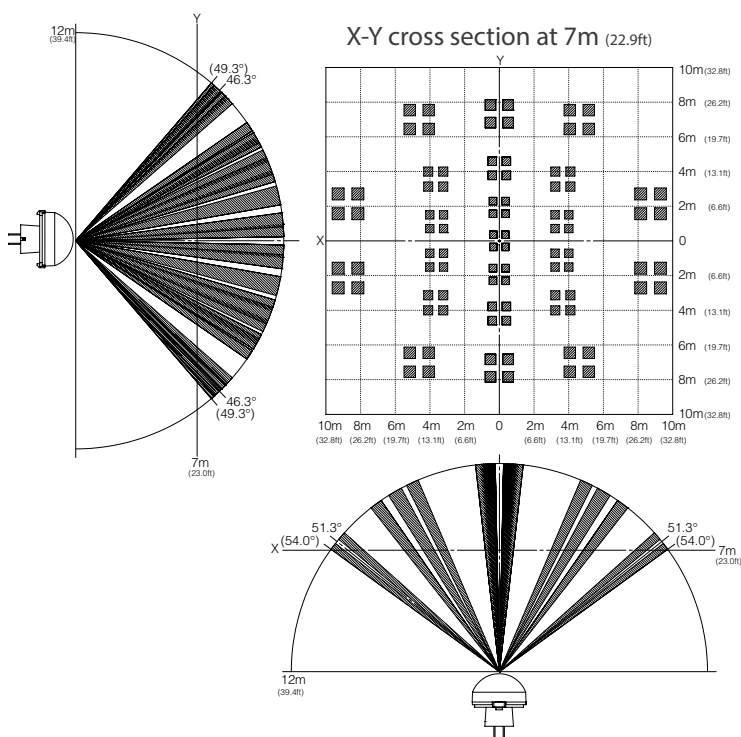

Notes	Standby current consumption	Output type	Sensitivity	White	Black	Pearl White
High-end	1μA	Digital (open drain)	Standard	EKMB1103111	EKMB1103112	EKMB1103113
	2μA	Digital (open drain)	Standard	EKMB1203111	EKMB1203112	EKMB1203113
Economy	6μA	Digital (open drain)	Standard	EKMB1303111K	EKMB1303112K	EKMB1303113K
	170μA	Digital (open drain)	Standard	EKMC1603111	EKMC1603112	EKMC1603113
	170μA	Analog (op amp)	Adjustable	EKMC2603111K	EKMC2603112K	EKMC2603113K
Special	6μA	Digital (open drain)	High	Please contact us if a higher or a lower sensitivity is required.		
	170μA	Digital (open drain)	High			
	170μA	Digital (open drain)	Low			

Note: The specification shows the X-Y cross section at 5m.

## EKM - Lensless Type



Small sensor elements with a very high sensitivity (D, NEP)  
 High electromagnetic noise withstand capability  
 Superior signal-to-noise ratio

Please contact us whenever a customized lens is required, the sensor shall be used with an external lens or for the design data of the pin-hole lens

Detection sensitivity	Average: 5.6 $\mu$ W/cm <sup>2</sup> Maximum: 7.6 $\mu$ W/cm <sup>2</sup>
-----------------------	--

Detection sensitivity is measured by following system

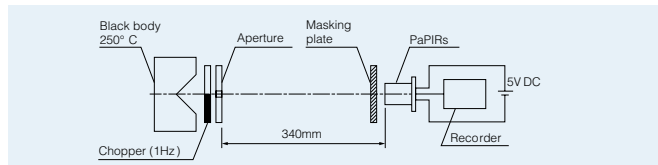

Further information on electrical characteristics please see page 16

### Typical applications

- › Pin-hole lens
- › Combination with lenses from external suppliers

### Dimension (in mm, inches in brackets)

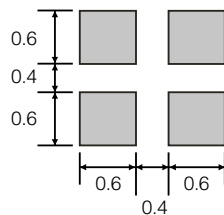
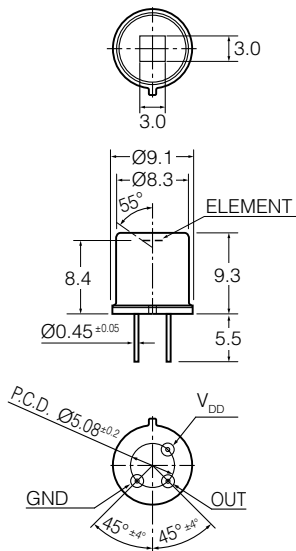

### Detection area

Pin-hole lens example

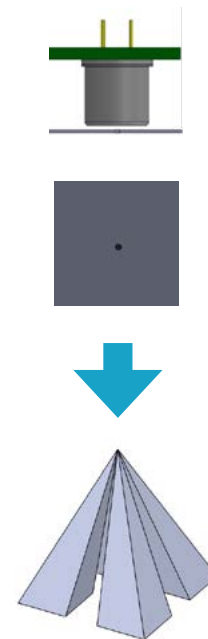

Notes	Standby current consumption	Output type	Sensitivity	Part numbers
High-end	1 $\mu$ A	Digital (open drain)	Standard	EKMB1100100
	2 $\mu$ A	Digital (open drain)	Standard	EKMB1200100
Economy	6 $\mu$ A	Digital (open drain)	Standard	EKMB1300100K
	170 $\mu$ A	Digital (open drain)	Standard	EKMC1600100
	170 $\mu$ A	Analog (op amp)	Adjustable	EKMC2600100K
Special	6 $\mu$ A	Digital (open drain)	High	Please contact us if a higher or a lower sensitivity is required.
	170 $\mu$ A	Digital (open drain)	High	
	170 $\mu$ A	Digital (open drain)	Low	



## EKM - Characteristics

## EKM - Maximum rated values

Items	EKMB series	EKMC series
Power supply voltage	-0.3 to 4.5V DC	-0.3 to 7V DC
Ambient temperature	-20 to 60°C -20 to 55°C (high sensitivity type) (no frost, no condensation)	
Storage temperature	-20 to 70°C	

## EKM - Electrical characteristics (digital output types)

Item	Symbol		EKMB11□ series (1μA)	EKMB12□ series (2μA)	EKMB13□K series (6μA)	EKMC16□ series (170μA)	Conditions
Operating voltage	$V_{DD}$	Max	4.0V DC			6.0VDC	-
		Min	2.3V DC			3.0VDC	
Current consumption (in standby/sleep mode) Note 1	$I_w$	Ave	1μA	2μA	6μA	170μA	Ambient temperature: 25°C $I_{OUT} = 0A$ EKMB series: $V_{DD} = 3VDC$ EKMC series: $V_{DD} = 5VDC$
Output current (during detection period) Note 2	$I_{OUT}$	Max	100μA				Ambient temperature: 25°C $V_{OUT} \geq V_{DD} - 0.5VDC$
Output voltage (during detection period)	$V_{OUT}$	Min	$V_{DD} - 0.5V$				Ambient temperature: 25°C
Circuit stability time (when voltage is applied)	$t_{WU}$	Ave	25 seconds		-	-	Ambient temperature: 25°C $I_{OUT} = 0A$ EKMB series: $V_{DD} = 3VDC$ EKMC series: $V_{DD} = 5VDC$
		Max	210 seconds	10 seconds	30 seconds		

Note 1: The total current consumption during detection is the current consumption in standby mode ( $I_w$ ) plus the output current ( $I_{OUT}$ ). For the 1μA type the average current consumption ( $I_w$ ) is 1μA in sleep mode and 1.9μA in standby mode. Please also refer to the timing charts on the next page.

Note 2: Please select an output resistor (pull-down concept) in accordance with  $V_{OUT}$  so that the output current is maximum 100μA.

## EKM - Electrical characteristics (analog output)

Item	Symbol	EKMC26□K series		Remarks
Operating voltage	$V_{DD}$	Max	5.5V	-
		Min	3.0V	
Current consumption (in standby mode) Note 1	$I_w$	Ave	170μA	Ambient temperature = 25°C $I_{OUT} = 0A$
		Max	350μA	
Output current (during detection period) Note 2	$I_{OUT}$	Max	200μA	-
Analog output saturated voltage	$V_H$	High	Min. 1.9V	-
	$V_L$	Low	Max. 0.2V	-
Output offset voltage (at non detection)	$V_{OFF}$	Max	1.2V	Ambient temperature: 25°C Steady output voltage at non detection
		Ave	1.1V	
		Min	1.0V	
Steady noise	$V_N$	Max	150mV <sub>pp</sub>	-
		Ave	80mV <sub>pp</sub>	
Circuit stability time (after applying voltage)	$t_{WU}$	Max	30 seconds	Ambient temperature: 25°C $I_{OUT} = 0A$

Note 1: The total current consumption during detection is the current consumption in standby mode ( $I_w$ ) plus the output current ( $I_{OUT}$ ).

Note 2: The output offset voltage has a certain tolerance. Please assure to measure the offset voltage before setting the upper and lower threshold values. Otherwise the threshold window could be unsymmetrical relative to the offset voltage.

Timing chart

2µA / 6µA / 170µA type (digital output)

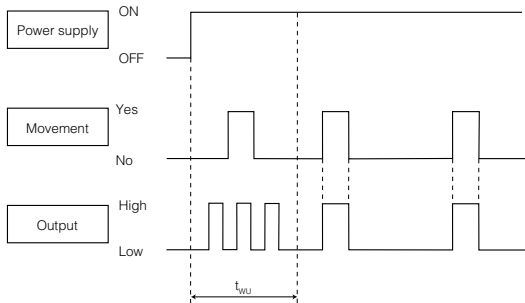

Explanation of the timing

$t_{wu}$  Circuit stability time: about 25 seconds (typ.) for 2µA type, max. 10 seconds for 6µA type, max. 30 seconds for 170µA type.

While the circuitry is stabilizing after the power is turned on, the sensor output is not fixed in the High or Low state. This is true regardless of whether or not the sensor has detected anything.

1µA type (digital output)

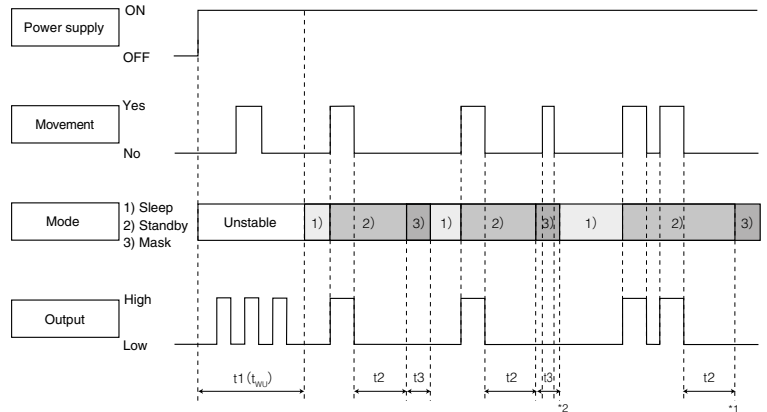

Explanation of modes

- 1) Sleep mode: When the output is Low. The electrical current consumption is around 1µA
- 2) Standby mode: After the sensor's output has reached High status, the sensor switches to standby mode. The electrical current consumption gets close to 1.9µA. When the sensor's output returns to its Low value after the "hold time" has expired, the sensor switches again to sleep mode.
- 3) Mask mode: Time during which the output is forced to Low status after the end of the standby mode. (No detection is possible during this period.)

Explanation of the timing

- t1) ( $t_{wu}$ ) Circuit stability time: about 25 seconds (typ.)  
While the circuitry is stabilizing after the power is turned on, the sensor output is not fixed in the High or Low state. This is true regardless of whether or not the sensor has detected anything.
- t2) Standby hold time: About 2.6 seconds (typ.) after the last detection of a signal. (\*1)
- t3) Mask time: About 1.3 seconds (typ.) During this stage, even if the sensor detects something, the output will not switch to High. (\*2)

170µA type (analog output)

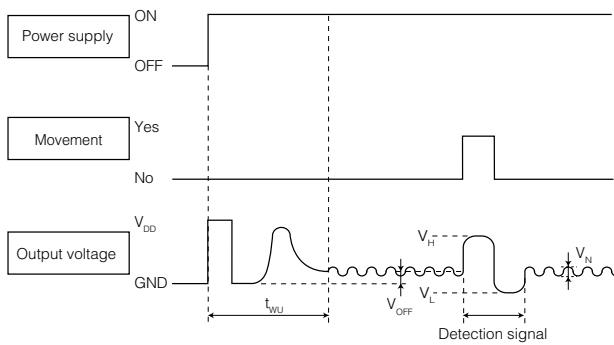

Explanation of the timing

$t_{wu}$  Circuit stability time: max. 30 seconds

While the circuitry is stabilizing after the power is turned on, the sensor output is not fixed. This is true regardless of whether or not the sensor has detected anything.

IMPORTANT:

The analog types are not temperature compensated.  
Please contact us for further information and design-in support.

### AMN - Standard Detection Type



Small lens diameter of only 9.5mm

Specified detection distance (Note 1)	up to 5m
Typical ceiling installation height (Note 2)	3m
Field of view	120° x 106°
Detection zones	64
<b>Note 1:</b> > ΔT ≥ 4°C > Object speed: 1m/s > Object size: 700 x 250mm > Crossing 2 detection zones	<b>Note 2:</b> The sensitivity of passive infrared sensors is influenced by environmental conditions, so a performance evaluation test under representative conditions is recommended

#### Typical applications

- > Lighting controls
- > Heaters
- > Ventilators and air conditioners
- > Multi-functional printers

Further information on electrical characteristics please see page 22

#### Dimension (in mm, inches in brackets)

#### Detection area

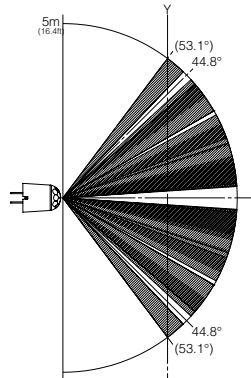
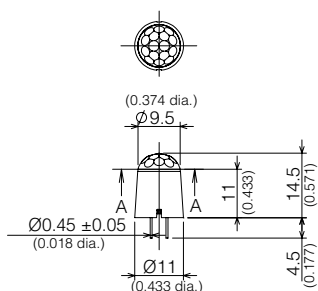

X-Y cross section at 3m (9.8ft)

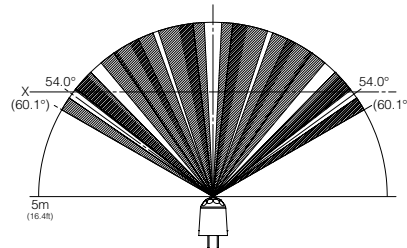
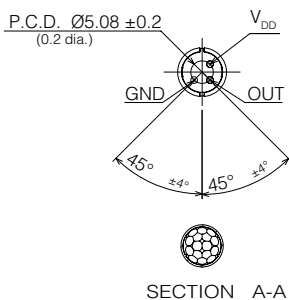
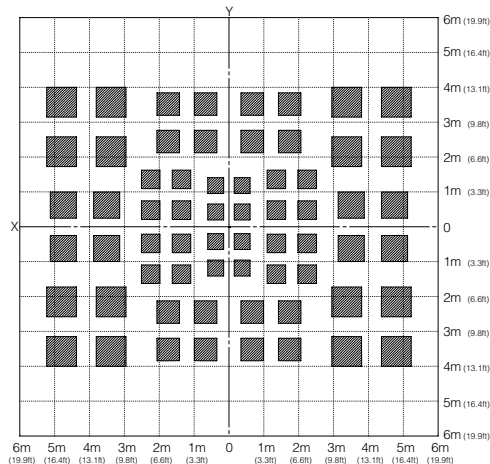

Notes	Standby current consumption	Output type	Sensitivity	White	Black
NaPiOn 2nd generation	170µA	Digital (open drain)	Standard	AMN31112	AMN31111

Note: The specification shows the X-Y cross section at 2.5m.

## AMN - Slight Motion Detection Type



Optimized for small movements

Specified detection distance (Note 1)	up to 2m - 3.3m
Typical ceiling installation height (Note 2)	3m
Field of view	107° x 106°
Detection zones	104
<b>Note 1:</b> > $\Delta T \geq 4^{\circ}C$ > Object speed: 0.5m/s > Object size: 200mm x 200mm > Crossing 1 detection zone	<b>Note 2:</b> The sensitivity of passive infrared sensors is influenced by environmental conditions, so a performance evaluation test under representative conditions is recommended

### Typical applications

- > Lighting controls
- > Heaters
- > Ventilators and air conditioners
- > Multi-functional printers

Further information on electrical characteristics please see page 22

### Dimension (in mm, inches in brackets)

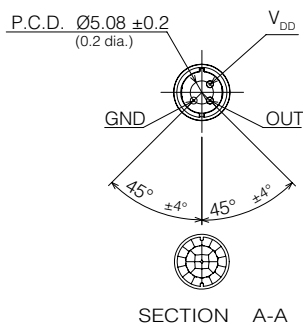
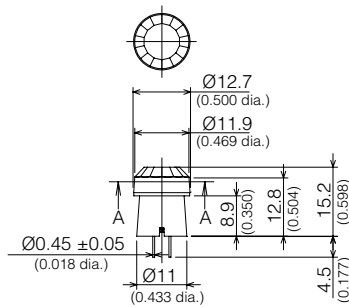

### Detection area

X-Y cross section at 3m (9.8ft)

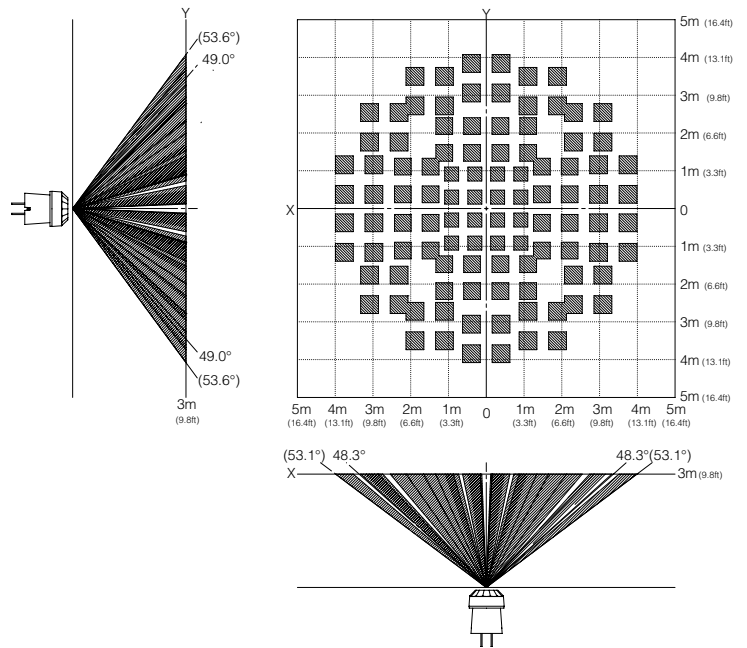

Notes	Standby current consumption	Output type	Sensitivity	White	Black
NaPiOn 2nd generation	170µA	Digital (open drain)	Standard	AMN32112	AMN32111

Note: The specification shows the X-Y cross section at 2m.

### AMN - Spot Detection Type



Flat lens  
Lens diameter 8.9mm

Specified detection distance (Note 1)	up to 5m - 5.6m
Typical ceiling installation height (Note 2)	5m
Field of view	57° x 42°
Detection zones	24
Note 1: > ΔT ≥ 4°C > Object speed: 1m/s > Object size: 700 x 250mm > Crossing 2 detection zones	Note 2: The sensitivity of passive infrared sensors is influenced by environmental conditions, so a performance evaluation test under representative conditions is recommended

#### Typical applications

- > Vending machines
- > Multi-functional printers
- > Intrusion alarm sensors for windows and doors
- > Digital signage

Further information on electrical characteristics please see pag 22

#### Dimension (in mm, inches in brackets)

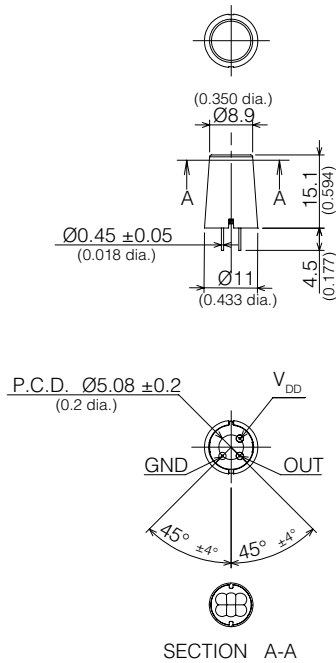

#### Detection area

X-Y cross section at 5m (16.4ft)

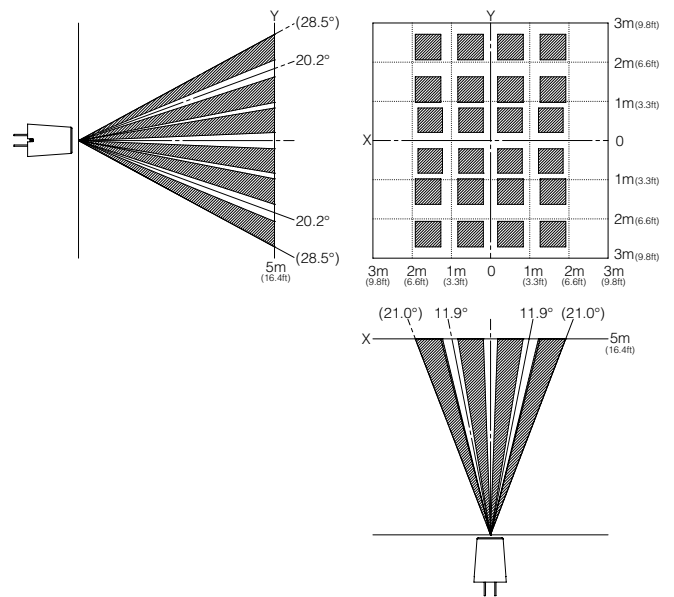

Notes	Standby current consumption	Output type	Sensitivity	White	Black
NaPiOn 2nd generation	170µA	Digital (open drain)	Standard	AMN33112	AMN33111

### AMN - 10m Detection Type (long distance)



Specified detection distance (Note 1)	up to 5 - 10m
Typical ceiling installation height (Note 2)	5m
Field of view	120° x 107°
Detection zones	80
<b>Note 1:</b> > $\Delta T \geq 4^{\circ}C$ > Object speed: 1m/s > Object size: 700 x 250mm > Crossing 2 detection zones	<b>Note 2:</b> The sensitivity of passive infrared sensors is influenced by environmental conditions, so a performance evaluation test under representative conditions is recommended

#### Typical applications

- > Lighting controls
- > Heaters
- > Ventilators and air-conditioners

Further information on electrical characteristics please see page 22

#### Dimension (in mm, inches in brackets)

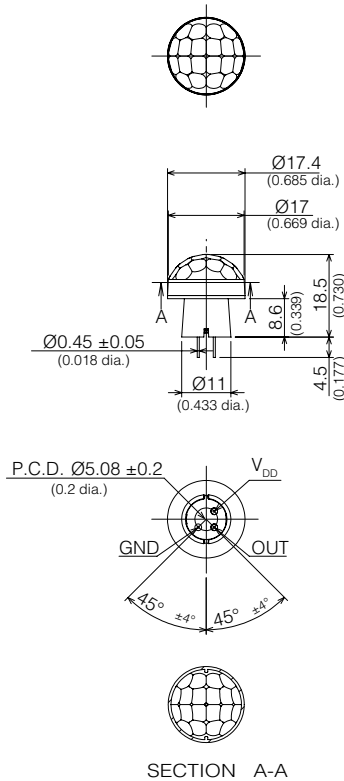

#### Detection area

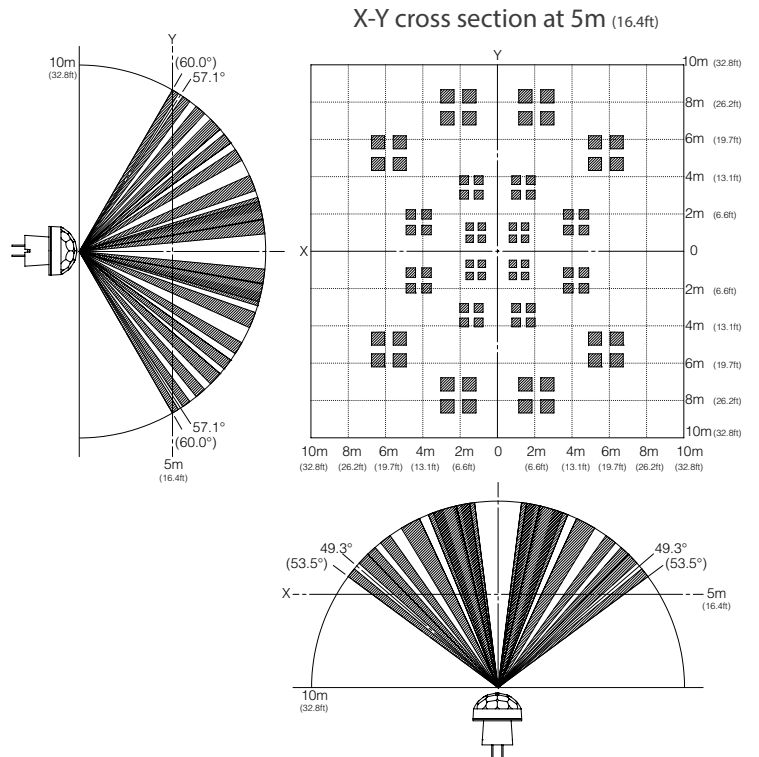

Notes	Standby current consumption	Output type	Sensitivity	White	Black
NaPiOn 2nd generation	170 $\mu$ A	Digital (open drain)	Standard	AMN34112	AMN34111

## AMN - Characteristics

### AMN - Maximum rated values (digital output)

Items	Value
Power supply voltage	-0.3 to 7VDC
Ambient temperature	-20 to +60°C (no frost, no condensation)
Storage temperature	-20 to +70°C

### AMN - Electrical characteristics (digital output)

Items	Symbol	AMN3* series		Conditions
		Max	Min	
Operating voltage	$V_{DD}$	Max	6.0VDC	-
		Min	3.0VDC	
Current consumption (in standby mode) Note 1	$I_W$	Ave	170 $\mu$ A	Ambient temperature: 25°C $I_{OUT} = 0A$ $V_{DD} = 5VDC$
Output current (during detection) Note 2	$I_{OUT}$	Max	100 $\mu$ A	Ambient temperature: 25°C $V_{OUT} \geq V_{DD} - 0.5VDC$
Output voltage (during detection)	$V_{OUT}$	Min	$V_{DD} - 0.5V$	Ambient temperature: 25°C
Circuit stability time (when voltage is applied) Note 3	$t_{WU}$	Max	30 seconds	Ambient temperature: 25°C $I_{OUT} = 0A$ $V_{DD} = 5VDC$

Note 1: The total current consumption is equal to the current consumption in standby mode ( $I_W$ ) plus the output current ( $I_{OUT}$ ).

Note 2: Please select an output resistor (pull-down concept) in accordance with  $V_{OUT}$  so that the output current is maximum 100 $\mu$ A. If the output current is more than 100 $\mu$ A, this may cause false alarms.

Note 3: The sensor temperature has to be constant for the time specified.

### Digital output

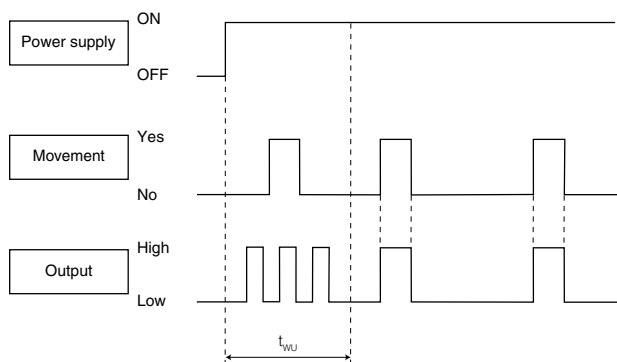

### Explanation of the timing

$t_{WU}$  Circuit stability time: max. 30 seconds

While the circuitry is stabilizing after the power is turned on, the sensor output is not fixed in the High or Low state. This is true regardless of whether or not the sensor has detected anything.



## Cautions for use

### Basic principles

PaPIRs are pyroelectric infrared sensors that detect variations in infrared rays. However, detection may not be successful in the following cases: lack of movement or no temperature change in the heat source. They could also detect the presence of heat sources other than a human body. Efficiency and reliability of the system may vary depending on the actual operating conditions:

- 1) Detecting heat sources other than the human body, such as:
  - a) small animals entering the detection area
  - b) When a heat source, for example sun light, incandescent lamp, car headlights etc., or strong light beam hit the sensor regardless whether the detection area is inside or outside.
  - c) Sudden temperature change inside or around the detection area caused by hot or cold wind from HVAC, or vapor from a humidifier, etc.
- 2) Difficulty in sensing the heat source
  - a) Glass, acrylic or similar materials standing between the target and the sensor may not allow a correct transmission of infrared rays.
  - b) Non-movement or quick movements of the heat source inside the detection area. (Please refer to the table on page 8 or 11 for details about movement speed.)
- 3) Expansion of the detection area
 

In case of a considerable difference in the ambient temperature and the human body temperature, the detection area may be larger than the configured detection area.
- 4) Malfunction / Detection error
 

On rare occasions, an erroneous detection signal may be output due to the nature of pyroelectric element. When the application cannot tolerate erroneous detection signals, take countermeasures by introducing a pulse-count circuit, etc.
- 5) Detection distance
 

Panasonic's PIR Motion sensors state the detection distance in the specifications because they are usually provided with the lens (please refer to item 6 for lensless types). The PIR Motion sensor could detect variations in infrared rays however such variations are decided by following three factors.

  - The temperature difference between the target and the surroundings:  
The larger the temperature difference, the easier it is to detect targets.
  - Movement speed: If the target is moving at a slower or faster speed than specified in the tables, the detection ability may be lower.
  - Target size: The human body is the standard. If the target is smaller or larger than specified in the table, the detection ability may be lower.

The detection distance explained in our data sheet is defined by the three factors mentioned above. Panasonic's standard for the temperature difference between the target and the surrounding is defined as 4°C. The larger the temperature difference, the longer the detection distance. If the temperature difference is 8°C, which is twice as much as the standard, the detection distance will be approx. 1.4 times longer than the distance at 4°C. For example, if targets at a distance of 5m can be detected at 4°C, then the sensor can detect targets at a distance of 7m at 8°C. (This is based on the theory that the detection sensitivity will vary inversely with the square of the distance.)
- 6) Lensless Type
 

The lensless type cannot detect any targets because it is not possible to focus infrared variations into the sensor chip. It is not possible to determine the detection distance and the field of view without a lens. Please provide your own lens based on your lens design concept.
- 7) Lens material and the plate setting in front of the lens
 

Typically, the only material that can be passed by infrared rays is Polyethylene. (The lens material of Panasonic's PIR Motion sensors is "High density polyethylene, HDPE") When you need to set a plate in front of the lens, please choose one made from the Polyethylene. Please note the thickness or color of the plate will affect the detection ability, e.g. it may make the detection distance shorter. Therefore, please confirm by testing the sensor with the plate under realistic conditions.

### Cautions

- 1) Refer to the newest specification regarding optimal operating environment conditions.
- 2) Do not solder with a soldering iron above 350°C (662°F) or for more than 3 seconds. This sensor should be hand-soldered.
- 3) To maintain stability of the product, always mount it on a printed circuit board.
- 4) Do not use liquids to wash the sensor. If washing fluid gets into the lens, it can reduce the performance.
- 5) Do not use a sensor after it has fallen on the ground.
- 6) The sensor may be damaged by  $\pm 200$  volts of static electricity. Avoid direct hand contact with the pins and be very careful when operating the product.
- 7) When wiring the product, always use shielded cables and minimize the wiring length to prevent noise disturbances.
- 8) The inner circuit board can be destroyed by a voltage surge. The use of surge absorption elements is highly recommended. Surge resistance: below the power supply voltage value indicated in the section on maximum rated values.
- 9) Please use a stabilized power supply. Noise from the power supply can cause operating errors. Noise resistance: max.  $\pm 20V$  (square waves with a width of 50ns or 1 $\mu$ s) To reduce the effect of noise from the power supply, install a capacitor on the sensor's power supply pin.
- 10) Operation errors can be caused by noise from static electricity, lightnings, cell phones, amateur radio, broadcasting offices, etc
- 11) The detection performance can be reduced by dirt on the lens, please be careful.
- 12) The lens is made of soft materials (Polyethylene). Please avoid adding weight or impacts that may change its shape, causing operation errors or reduced performance.
- 13) The specified temperature and humidity levels are suggested to prolong usage. However, they do not guarantee durability or environmental resistance. Generally, high temperatures or high humidity levels will accelerate the deterioration of electrical components. Please consider both the planned usage and environment to determine the expected reliability and length of life of the product.
- 14) Do not attempt to clean this product with detergents or solvents such as benzene or alcohol, as these can cause shape or color alterations.
- 15) Avoid storage in high, low temperature or liquid environments. Also, avoid storage in environments containing corrosive gas, dust, salty air etc. Adverse conditions may cause performance deterioration and the sensor's main part or the metallic connectors could be damaged.
- 16) Storage conditions  
Temperature: +5 to +40°C, humidity: 30 to 75%  
Please use within 1 year after delivery.

### Safety precautions

Obey the following precautions to prevent injury or accidents.

- 1) Do not use these sensors under any circumstance in which the range of their ratings, environment conditions or other specifications are exceeded. Using the sensors in any way which causes their specifications to be exceeded may generate abnormally high levels of heat, emit smoke, etc., resulting in damage to the circuitry and possibly causing an accident.
- 2) Our company is committed to making products of the highest quality and reliability. Nevertheless, all electrical components are subject to natural deterioration, and durability of a product will depend on the operating environment and conditions of use. Continued use after such deterioration could lead to overheating, smoke or fire. Always use the product in conjunction with proper fire-prevention, safety and maintenance measures to avoid accidents, reduction in product life expectancy or break-down.
- 3) Before connecting, check the pin layout by referring to the connector wiring diagram, specifications diagram, etc., to verify that the connector is connected properly. Mistakes made in connection may cause unforeseen problems in operation, generate abnormally high levels of heat, emit smoke, etc., resulting in damage to the circuitry.
- 4) Do not use any motion sensor which has been disassembled or remodeled.
- 5) Failure modes of sensors include short-circuiting, open-circuiting and temperature rises. If this sensor is to be used in equipment where safety is a prime consideration, examine the possible effects of these failures on the equipment concerned, and ensure safety by providing protection circuits or protection devices.  
Example : Safety equipment and devices, traffic signals, burglar and disaster prevention devices, controlling and safety device for trains and motor vehicles



North America

Europe

Asia Pacific

China

Japan

## Panasonic Electric Works

Please contact our Global Sales Companies in:

### Europe

▶ <b>Headquarters</b>	<b>Panasonic Electric Works Europe AG</b>	Caroline-Herschel-Strasse 100, 85521 Ottobrunn, Tel. +49 89 45354-1000, Fax +49 89 45354-1550, <a href="http://www.panasonic-electric-works.com">www.panasonic-electric-works.com</a>
▶ <b>Austria</b>	<b>Panasonic Electric Works Austria GmbH</b>	Josef Madersperger Str. 2, 2362 Biedermansdorf, Tel. +43 (0) 2236-26846, Fax +43 (0) 2236-46133 <a href="http://www.panasonic-electric-works.at">www.panasonic-electric-works.at</a>
	<b>Panasonic Industrial Devices Materials Europe GmbH</b>	Ennshafenstraße 30, 4470 Enns, Tel. +43 (0) 7223 883, Fax +43 (0) 7223 88333, <a href="http://www.panasonic-electronic-materials.com">www.panasonic-electronic-materials.com</a>
▶ <b>Benelux</b>	<b>Panasonic Electric Works Sales Western Europe B.V.</b>	De Rijn 4, 5684 PJ Best, Netherlands, Tel. +31 (0) 499 372727, <a href="http://www.panasonic-electric-works.nl">www.panasonic-electric-works.nl</a>
▶ <b>Czech Republic</b>	<b>Panasonic Electric Works Europe AG, organizační složka</b>	Administrative centre PLATINIUM, Veverí 3163/111, 616 00 Brno, Tel. +420 541 217 001, Fax +420 541 217 101, <a href="http://www.panasonic-electric-works.cz">www.panasonic-electric-works.cz</a>
▶ <b>France</b>	<b>Panasonic Electric Works Sales Western Europe B.V.</b>	Succursale française, 10, rue des petits ruisseaux, 91370 Verrières Le Buisson, Tél. +33 (0) 1 6013 5757, Fax +33 (0) 1 6013 5758, <a href="http://www.panasonic-electric-works.fr">www.panasonic-electric-works.fr</a>
▶ <b>Germany</b>	<b>Panasonic Electric Works Europe AG</b>	Caroline-Herschel-Strasse 100, 85521 Ottobrunn, Tel. +49 89 45354-1000, Fax +49 89 45354-2111, <a href="http://www.panasonic-electric-works.de">www.panasonic-electric-works.de</a>
▶ <b>Hungary</b>	<b>Panasonic Electric Works Europe AG</b>	Magyarországi Fióktelepe, 1117 Budapest, Alíz utca 4, Tel. +43 (0) 2236 26846 -25, Fax +43 (0) 2236 46133 <a href="http://www.panasonic-electric-works.hu">www.panasonic-electric-works.hu</a>
▶ <b>Ireland</b>	<b>Panasonic Electric Works UK Ltd.</b>	Irish Branch Office, Dublin, Tel. +353 (0) 14600969, Fax +353 (0) 14601131, <a href="http://www.panasonic-electric-works.co.uk">www.panasonic-electric-works.co.uk</a>
▶ <b>Italy</b>	<b>Panasonic Industry Italia srl</b>	Via del Commercio 3-5 (Z.I. Ferlina), 37012 Bussolengo (VR), Tel. +39 0456752711, Fax +39 0456700444, <a href="http://www.panasonic-electric-works.it">www.panasonic-electric-works.it</a>
▶ <b>Nordic Countries</b>	<b>Panasonic Electric Works Europe AG Panasonic Fire &amp; Security Europe AB</b>	Filial Nordic, Knarrarnäsgatan 15, 164 40 Kista, Sweden, Tel. +46 859476680, Fax +46 859476690, <a href="http://www.panasonic-electric-works.se">www.panasonic-electric-works.se</a>
▶ <b>Poland</b>	<b>Panasonic Electric Works Polska sp. z o.o</b>	Jungmansgatan 12, 21119 Malmö, Tel. +46 40 697 7000, Fax +46 40 697 7099, <a href="http://www.panasonic-fire-security.com">www.panasonic-fire-security.com</a>
▶ <b>Spain</b>	<b>Panasonic Electric Works España S.A.</b>	ul. Wołoska 9A, 02-583 Warszawa, Tel. +48 42 230 9633, <a href="http://www.panasonic-electric-works.pl">www.panasonic-electric-works.pl</a>
▶ <b>Switzerland</b>	<b>Panasonic Electric Works Schweiz AG</b>	Barajas Park, San Severo 20, 28042 Madrid, Tel. +34 913293875, Fax +34 913292976, <a href="http://www.panasonic-electric-works.es">www.panasonic-electric-works.es</a>
▶ <b>United Kingdom</b>	<b>Panasonic Electric Works UK Ltd.</b>	Grundstrasse 8, 6343 Rotkreuz, Tel. +41 (0) 41 7997050, Fax +41 (0) 41 7997055, <a href="http://www.panasonic-electric-works.ch">www.panasonic-electric-works.ch</a> Sunrise Parkway, Linford Wood, Milton Keynes, MK14 6 LF, Tel. +44 (0) 1908 231555, Fax +44 (0) 1908 231599, <a href="http://www.panasonic-electric-works.co.uk">www.panasonic-electric-works.co.uk</a>

### North & South America

▶ <b>USA</b>	<b>Panasonic Industrial Devices Sales Company of America</b>	Two Riverfront Plaza, 7th Floor, Newark, NJ 07102-5490, Tel. 1-8003-442-112, <a href="http://www.pewa.panasonic.com">www.pewa.panasonic.com</a>
--------------	--	---

### Asia Pacific / China / Japan

▶ <b>China</b>	<b>Panasonic Electric Works Sales (China) Co. Ltd.</b>	Tower C 3rd Floor, Office Park, NO.5 Jinghua South Street, Chaoyang District, Beijing 100020, Tel. +86-10-5925-5988, Fax +86-10-5925-5980
▶ <b>Hong Kong</b>	<b>Panasonic Industrial Devices Sales (HK) Co., Ltd.</b>	Suite 301, 3/F, Chinachem Golden Plaza, 77 Mody Road, TST East, Kowloon, Hong Kong, Tel. +852-2529-3956, Fax +852-2528-6991
▶ <b>Japan</b>	<b>Panasonic Corporation</b>	1006, Oaza Kadoma, Kadoma-shi, Osaka 571-8501, Japan, Tel. +81-6-6908-1121, <a href="http://www.panasonic.net">www.panasonic.net</a>
▶ <b>Singapore</b>	<b>Panasonic Industrial Devices Automation Controls Sales Asia Pacific</b>	No.3 Bedok South Road, Singapore 469269, Tel. +65-6299-9181, Fax +65-6390-3953