

INSTRUCTION MANUAL

TYPE RS485

VER1.0

I BRIEF INTRODUCTION

1.1 Product Overview

THE wind speed sensors are compact and lightweight, easy to carry and assemble. The three cup design concept can effectively obtain external environmental information. The shell is made of high quality aluminum alloy profiles, and the exterior is subjected to electroplating spray treatment, which has good anti-corrosion, Anti-corrosion and other characteristics, can guarantee the long-term use of the instrument rust-free phenomenon, at the same time with the internal smooth bearing system to ensure the accuracy of information collection. It is widely used in the measurement of wind speeds in environments such as greenhouses, environmental protection, weather stations, ships, docks, and breeding.

1.2 System Frame Diagram

PARAMETERS	TECHNICAL SPECIFICATIONS
MEASURING RANGE	0-30m/s
MEASURING ACCURACY	±1m/s
RESPONSE TIME	Less than 5 seconds
BAUD RATE	9600
COMMUNICATION PORT	RS485
POWER SUPPLY	12V-24V DC
POWER CONSUMPTION	<1W
OPERATING TEMPERATURE	-30-80°C

1.3 System Framework

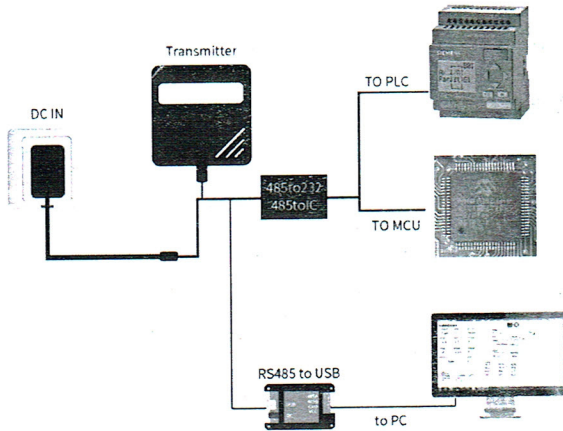

FIGURE 1 SINGLE-ENDED

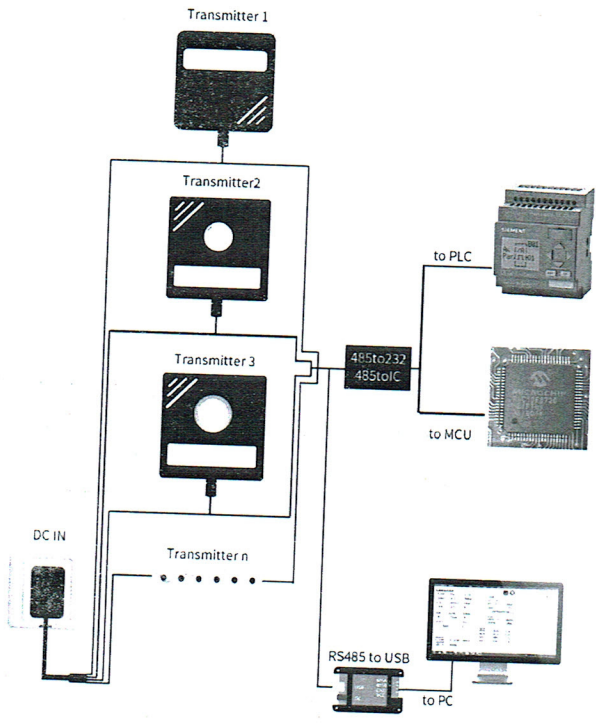

FIGURE 2 MUTIPLE-ENDED

II HARDWARE CONNECTIONS

2.1 CHECKING BEFORE INSTALLATION

Check the list of devices before installation:

Name	Number
THE SENSOR DEVICE	1
Wind speed 485 line	1
12V POWER ADAPTER (Optional)	1
WARRANTY CARD / CERTIFICATE	1
THE USB TO 485 DEVICE (Optional)	1

TABLE 1 List of Devices

2.1.1 Wiring method

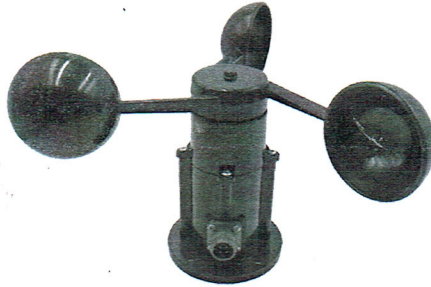

	Line Color	Description
Power	Brown	Power supply Positive
	Black	Power supply Negative
Communication	Blue	485-A
	White	485-B

The factory default is to provide 0.6 meters long wire, customers can extend the wire as needed or sequentially.

2.2 Installation Description

Flange mounting, threaded flange connection makes the lower part of the wind direction sensor firmly fixed on the flange plate, and four mounting holes with a diameter of 6mm are opened on the circumference of the chassis. Use bolts to

tightly fix it on the bracket to make the whole set. The instrument is kept at the best level, which ensures the accuracy of the wind direction data. The flange connection is easy to use and can withstand greater pressure.

2.3.1 Fixing method

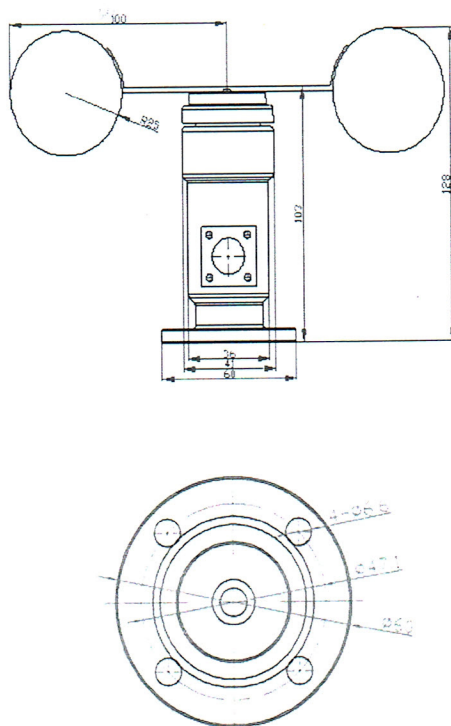

III COMMUNICATION PROTOCOL

3.1 Communication Basic Parameters

TABLE 2 Communication Basic Parameters

PARAMETERS	CONTENT
Code	8-bit binary
Data bits	8 bit
Parity bit	No
Stop bit	1 bit
Error checking	CRC (redundant loop code)
Baud rate	2400 bps/ 4800 bps/ 9600 bps can be set factory defaults to 9600 bps

For more information about MODBUS RTU please visit the website "www.modbus.org".

3.2 Register Address

Register Address	Plc Configuration Address	Content	Operation
0016H	40017	Wind speed (unit 0.1m/s)	Read-Only
0100H	40101	Device Address (0-252)	R/W
0101H	40102	Baud rate (2400/4800/9600)	R/W

TABLE 3 Register Address

3.4 Communication Protocol Examples and Explanations

3.4.1 Reading Wind Speed Value at Device Address 0x01

Inquiry Frame

Address Code	Function Code	Start Address	Data Length	CRC_L	CRC_H
0x01	0x03	0x00	0x00	0x65	0xCE
		0x16	0x01		

Answer Frames

(For example, reading a wind speed of 2.3m/s)

Address Code	Function Code	The Number Of Valid Bytes	Wind Speed Value	CRC_L	CRC_H
0x01	0x03	0x02	0x00	0xF8	0x4A
			0x17		

Wind speed:

0017 H (hexadecimal) = 23 => Wind Speed = 2.3m/s