

Sheet: /	
File: Gate.TrSeq.sch	
Title: 4x8 Gate Sequencer	
Size: A4	Date: 2020-04-05
KiCad E.D.A. kicad 5.1.5	Rev: A1
	Id: 1/9

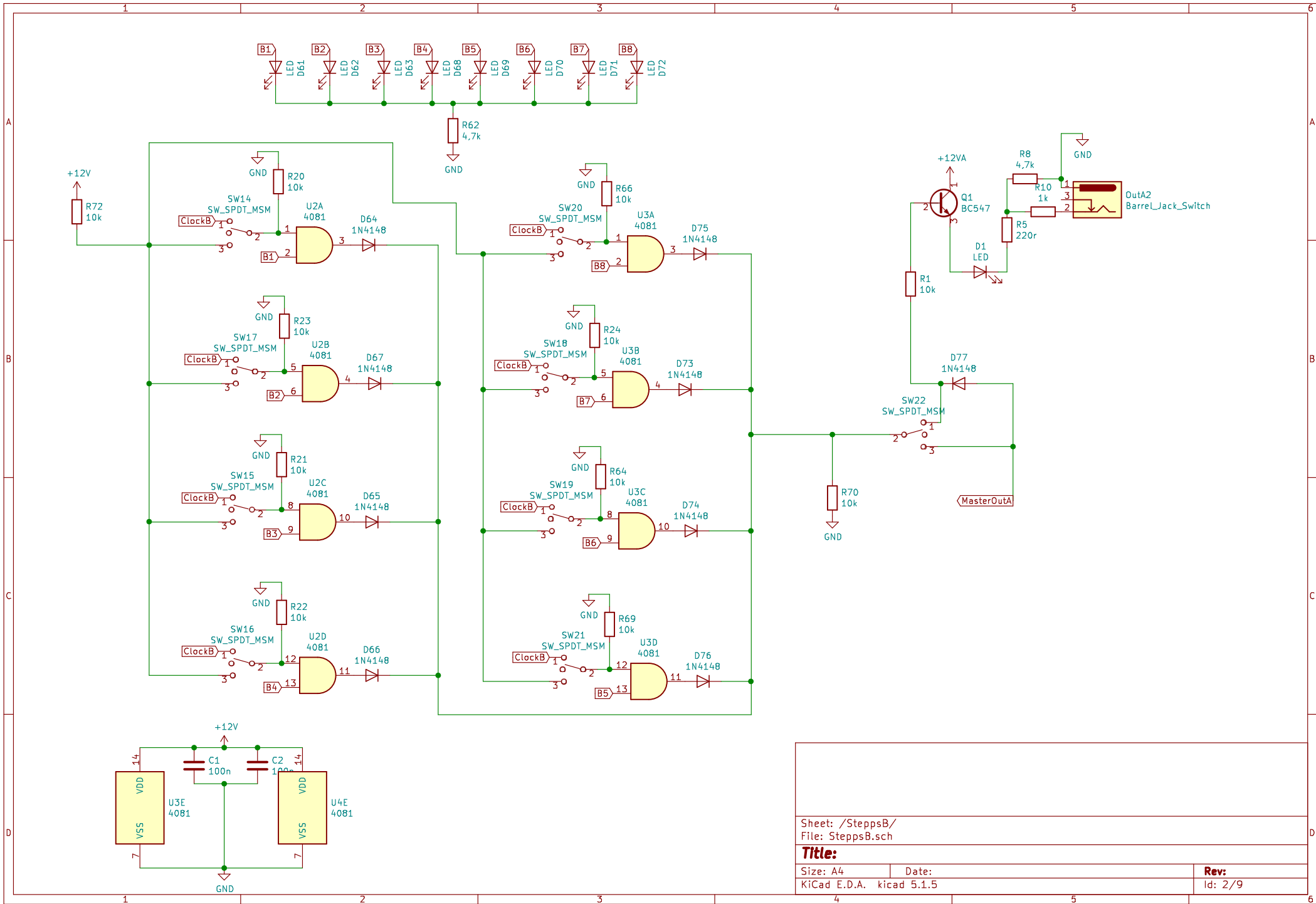

Sheet: /SteppsB/		Date:	
File: SteppsB.sch		KiCad E.D.A. kicad 5.1.5	
Title:		Rev:	
Size: A4	Date:	Id: 2/9	

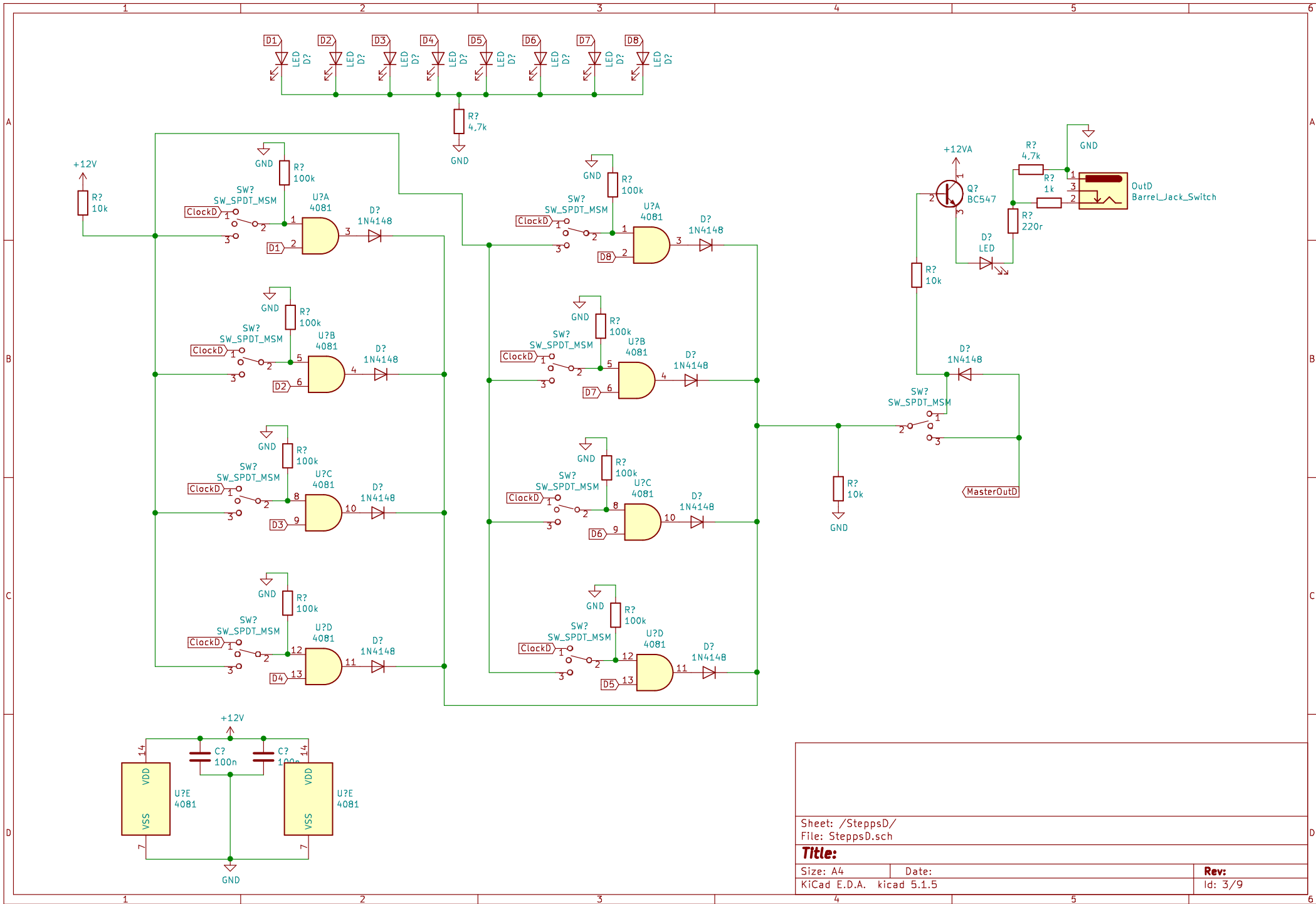

Sheet: /SteppsD/		Date:	
File: SteppsD.sch		Rev:	
Title:		Id: 3/9	
Size: A4	KiCad E.D.A. kicad 5.1.5		

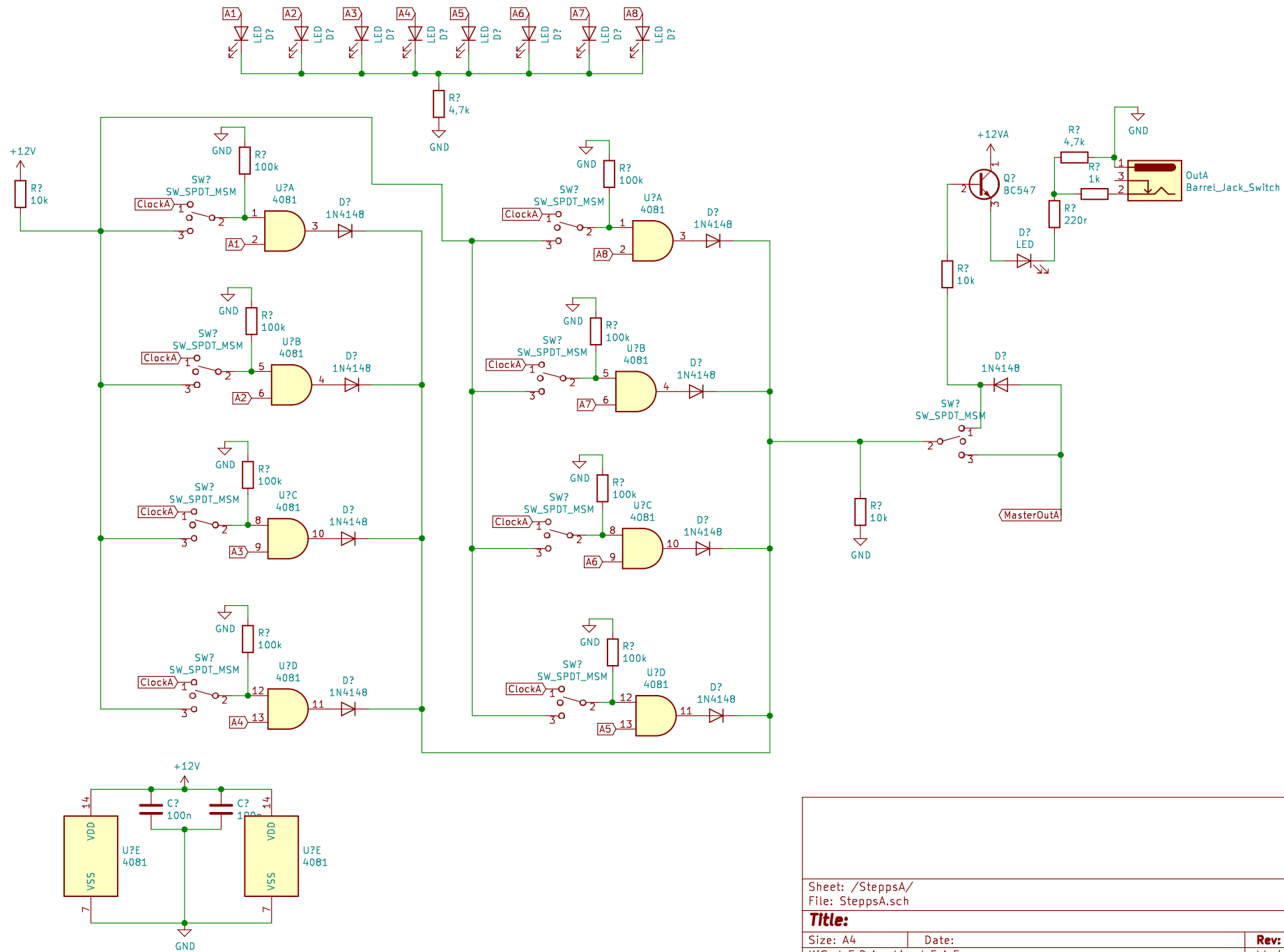

Sheet: /SteppsA/		Date:	
File: SteppsA.sch		Rev:	
Title:			
Size: A4	KiCad E.D.A. kicad 5.1.5	Id: 4/9	

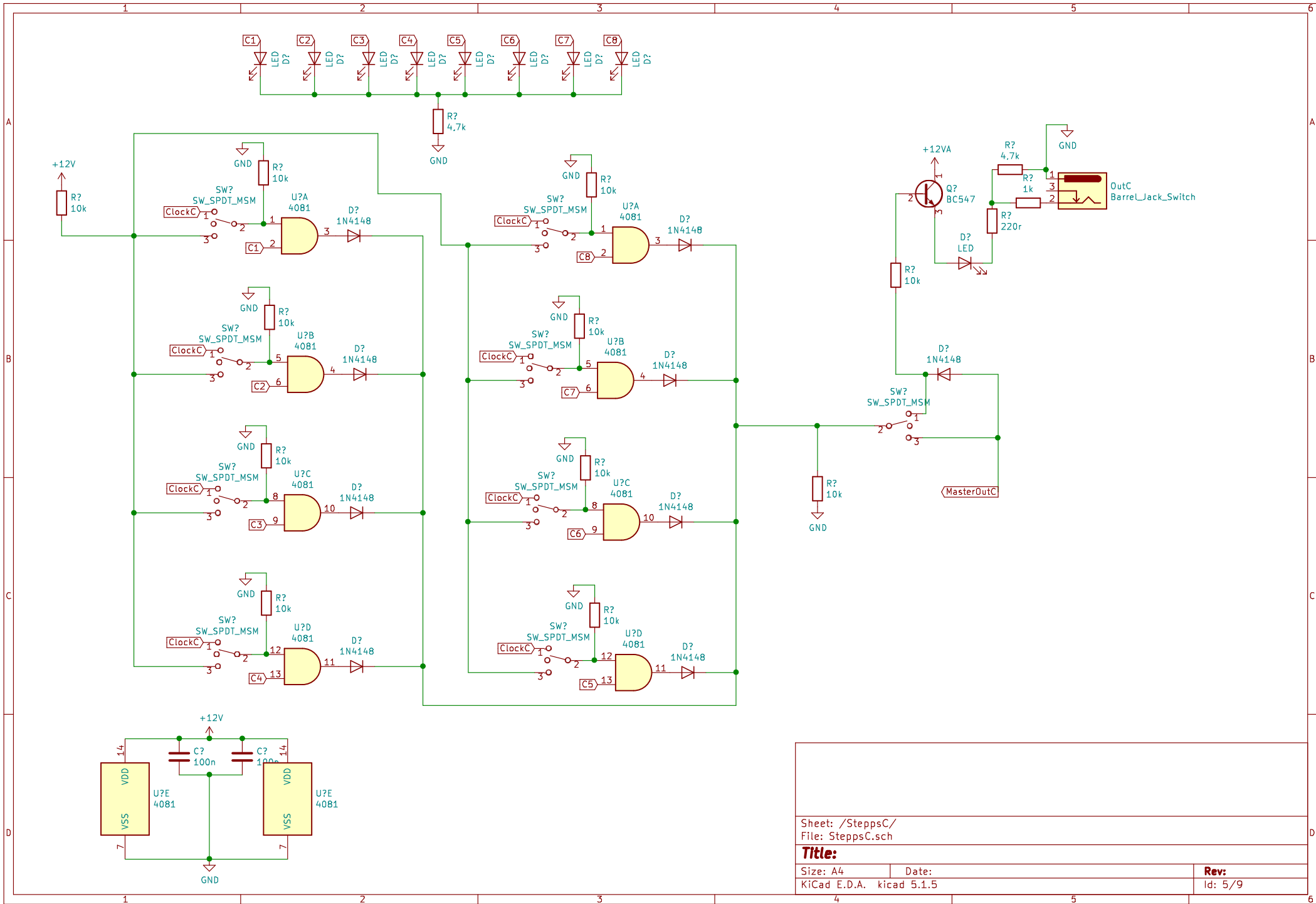

Sheet: /SteppsC/
 File: SteppsC.sch

Title:

Size: A4 Date:
 KiCad E.D.A. kicad 5.1.5

Rev:
 Id: 5/9

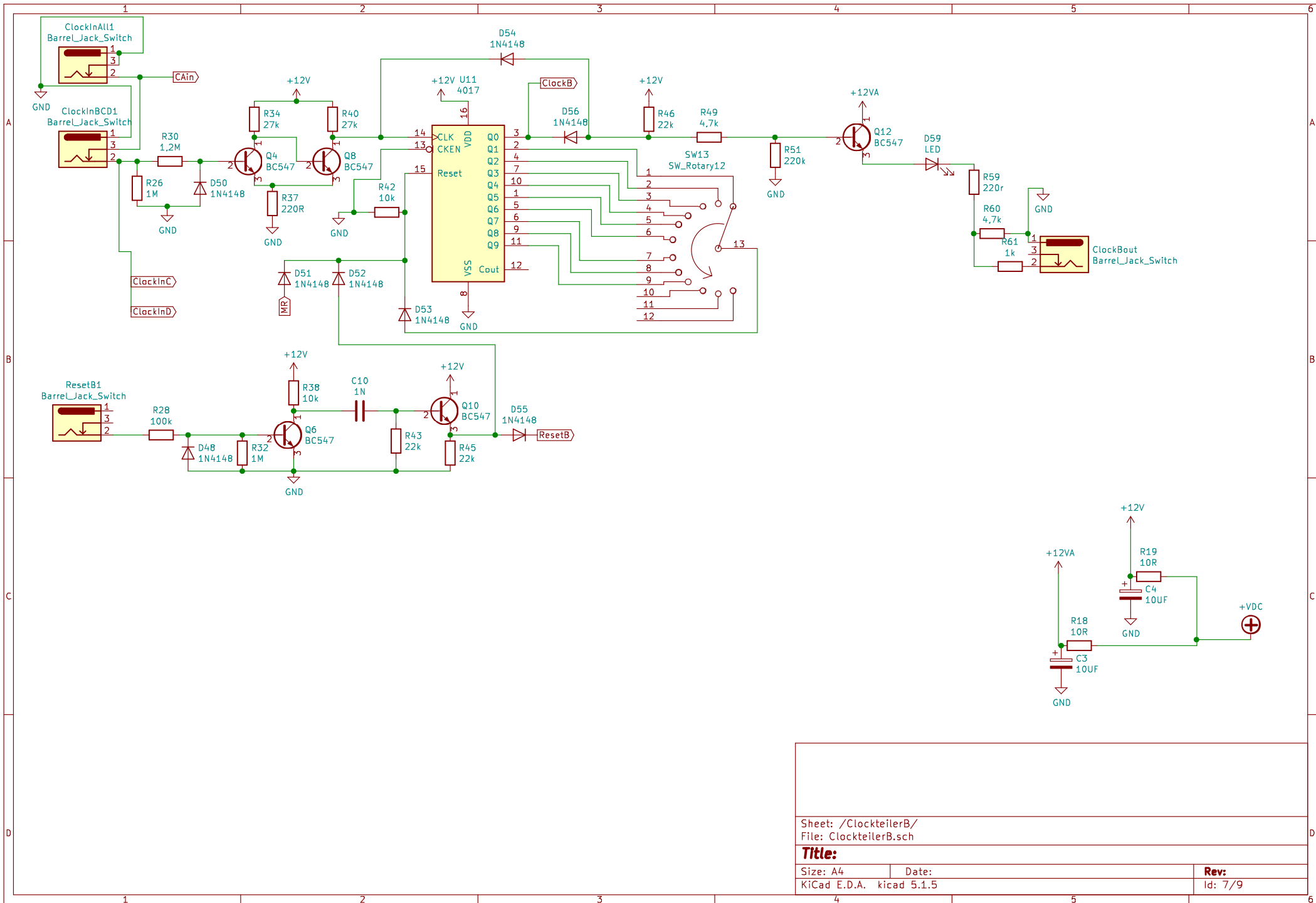

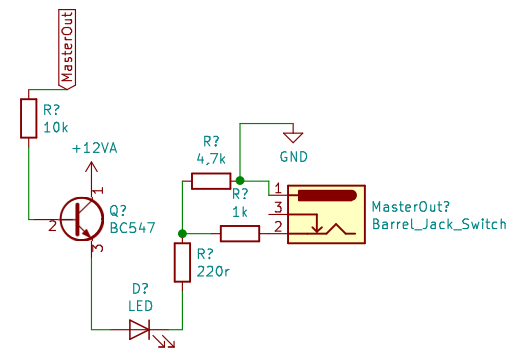
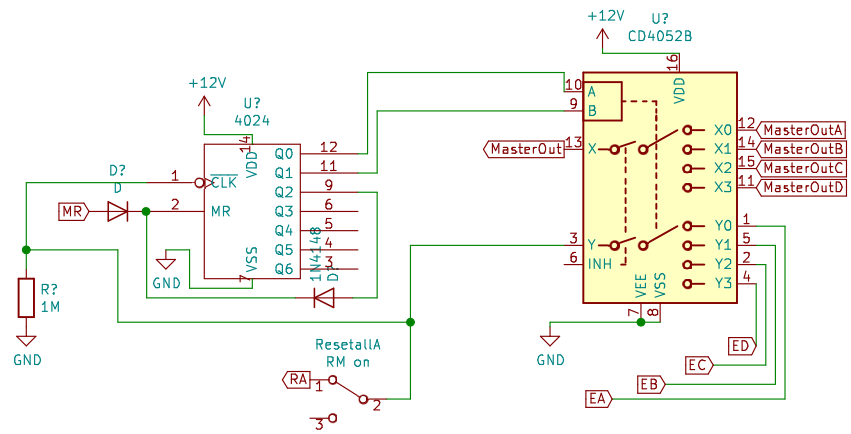

Sheet: /MasterOut/
 File: MasterOut.sch

Title:

Size: A4
 KiCad E.D.A. kicad 5.1.5

Date:

Rev:

Id: 9/9