

GENERAL

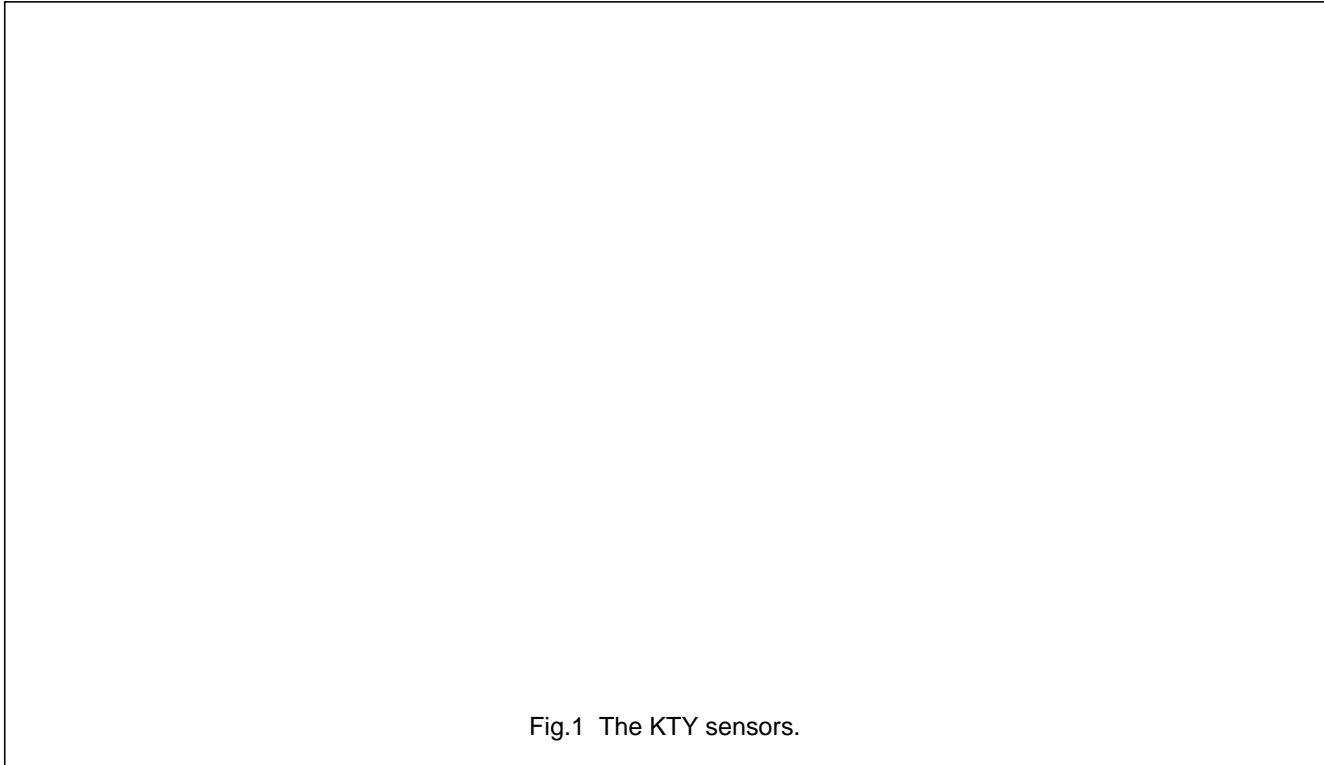

Fig.1 The KTY sensors.

With their high accuracy and excellent long term stability, the KTY series of silicon sensors in spreading resistor technology provide an attractive alternative to the more conventional sensors based on NTC or PTC technology. Their main advantages are:

- Long term stability
- Si batch process based technology
- Virtual linear characteristics.

Table 1 Drifts of Si Sensors

After 10000 hours permanent operation with nominal operating current at maximum operating temperature.

TYPE	TYPICAL DRIFT (K)	MAXIMUM DRIFT (K)
KTY81-1 KTY82-1	0.20	0.50
KTY81-2 KTY82-2	0.20	0.80
KTY83	0.15	0.40
KTY85	0.13	0.25

The properties of our temperature sensors are based on those of the chemical element silicon, and therefore sensor behaviour is as stable as this chemical element. This means that temperature drifts during the lifetime of the products are negligible. In recent tests this has been verified, when sensors operating at their maximum operating temperature for 10000 hours (equivalent to 1.14 years) have shown typical drifts of 0.2 K with a maximum of 0.4 K to 0.8 K.

Long term stability

Assuming that the sensor is typically used at half of the specified maximum temperature, our Si sensor will have a low drift as described in Table 1 for at least 450000 hours (equals 51 years). This calculation is based on the Arrhenius equation (activation energy = 0.7 eV).

Si batch process products

Because our products are based on Si technology, we indirectly benefit from progress in this field, due to development of microprocessors and computer memory etc. Additionally, this indirect benefit also extends to encapsulation technology, where the trend is towards miniaturization and high volume manufacture.

Virtual linear characteristics

Si temperature sensors show a virtually linear characteristic compared to the exponential characteristic of NTCs (see Fig.2). This means that Si temperature sensors have a TK (temperature coefficient) which is nearly constant over the complete temperature range. This characteristic can be ideally exploited when the sensor is used to provide, for example, temperature compensation for a microprocessor with integrated A/D converter.

Construction of the sensor: spreading resistance principle

The construction of the basic sensor chip is shown in Fig.3. The chip size is $\approx 500 \times 500 \times 240 \mu\text{m}$. The upper plane of the chip is covered by an SiO_2 insulation layer, in which a metallized hole with a diameter of $\approx 20 \mu\text{m}$ has been cut out. The entire bottom plane is metallized.

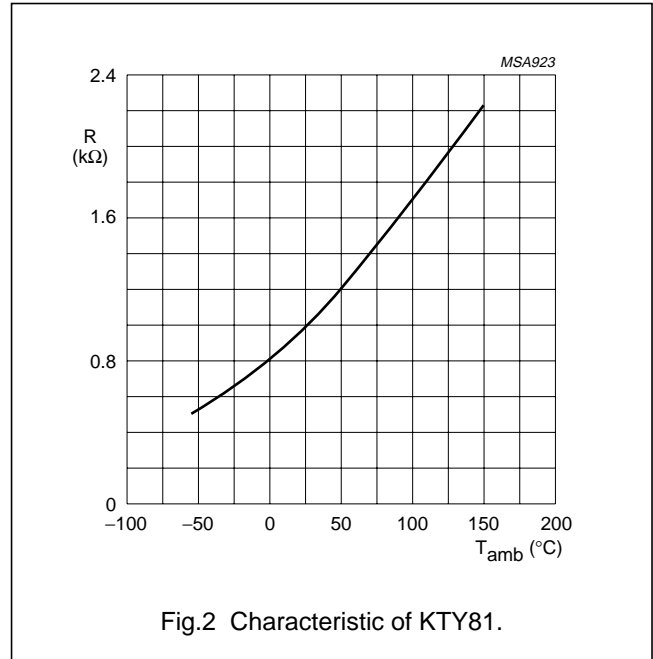

Fig.2 Characteristic of KTY81.

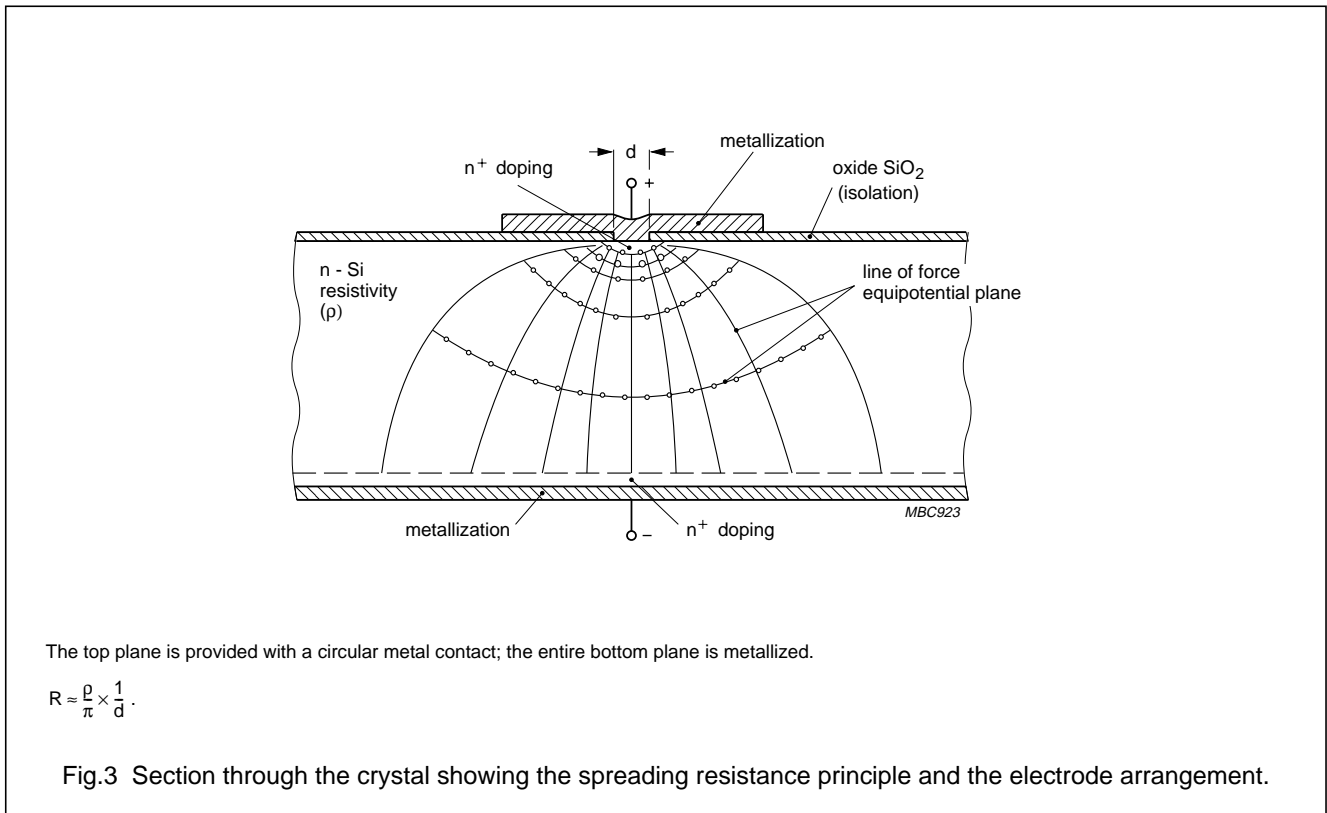

Fig.3 Section through the crystal showing the spreading resistance principle and the electrode arrangement.

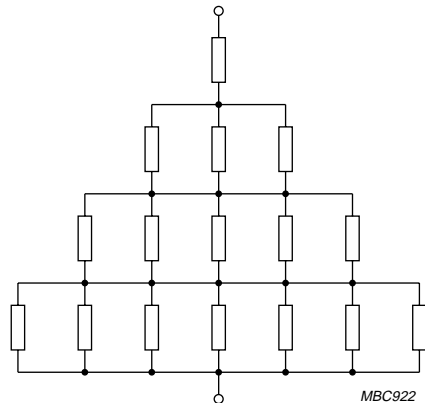

Fig. 4 Equivalent circuit symbolically representing the spreading resistance principle shown in Fig.3.

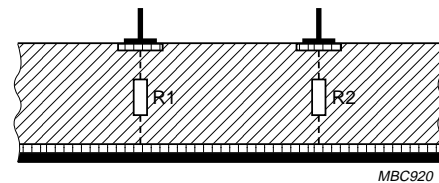

Fig.5 Setup consisting of two single sensors connected in series, but with opposite polarity.

This arrangement provides a conical current distribution through the crystal, hence the name 'spreading resistance' (see Fig.4). A major advantage of this arrangement is that the dependency of the sensor resistance on manufacturing tolerances is significantly reduced. The dominant part of the resistance is determined by the area close to the metallization hole which makes the setup independent of the Si crystal dimension tolerances. An n^+ region, diffused into the crystal beneath the metallization reduces barrier-layer effects at the metal-semiconductor junctions.

Figure 5 shows a second arrangement, effectively consisting of two single sensors connected in series, but with opposite polarity, which has the advantage of providing a resistance that is independent of current direction. This is in contrast to the single-sensor arrangement of Fig.3, which, for larger currents and temperatures above 100 °C, gives a resistance that varies slightly with the current direction.

Normally, silicon temperature sensors have a temperature limit of ≈ 150 °C, imposed by the intrinsic semiconductor properties of silicon. If, however, the single-sensor device is biased with its metal contact positive, the onset of intrinsic semiconductor behaviour is shifted to a higher temperature. This stems from the fact that a positive

voltage on the gold contact severely depletes the hole concentration in the upper n^+ diffusion layer, and so effectively insulates holes spontaneously generated within the body of the crystal due to its intrinsic nature. As a result the holes are prevented from contributing to the total current, and hence from affecting the resistance.

The twin-sensor arrangement shown in Fig.5 has been applied in the KTY81 and KTY82 series. These sensors, in SOD70 (KTY81) and SOT23 (KTY82) packages (Figs 6 and 7), are therefore polarity independent.

The KTY83/84/85 series use the more basic single-sensor arrangement. The simplicity of this arrangement allows the sensors to be produced in the compact SOD68; DO-34 (KTY83/84) and SOD80 (KTY85) packages (Figs 8 and 9, respectively). In addition to simplicity, another important advantage of the single-sensor device is the potential for operation at temperatures up to 300 °C. The KTY84 makes use of this property, being specifically designed for operation at temperatures up to 300 °C. Table 2 provides an overview of product key characteristics.

Table 2 Overview of product - key characteristics

FAMILY TYPE	R ₂₅ (Ω)	AVAILABLE TOLERANCE (ΔR)	T _{oper} RANGE (°C)	PACKAGE
KTY81-1	1000	±1% up to ±5%	-55 to 150	SOD70
KTY81-2	2000	±1% up to ±5%	-55 to 150	SOD70
KTY82-1	1000	±1% up to ±5%	-55 to 150	SOT23
KTY82-2	2000	±1% up to ±5%	-55 to 150	SOT23
KTY83-1	1000	±1% up to ±5%	-55 to 175	SOD68 (DO-34)
KTY84-1	1000 (R ₁₀₀)	±3% up to ±5%	-40 to 300	SOD68 (DO-34)
KTY85-1	1000	±1% up to ±5%	-40 to 125	SOD80

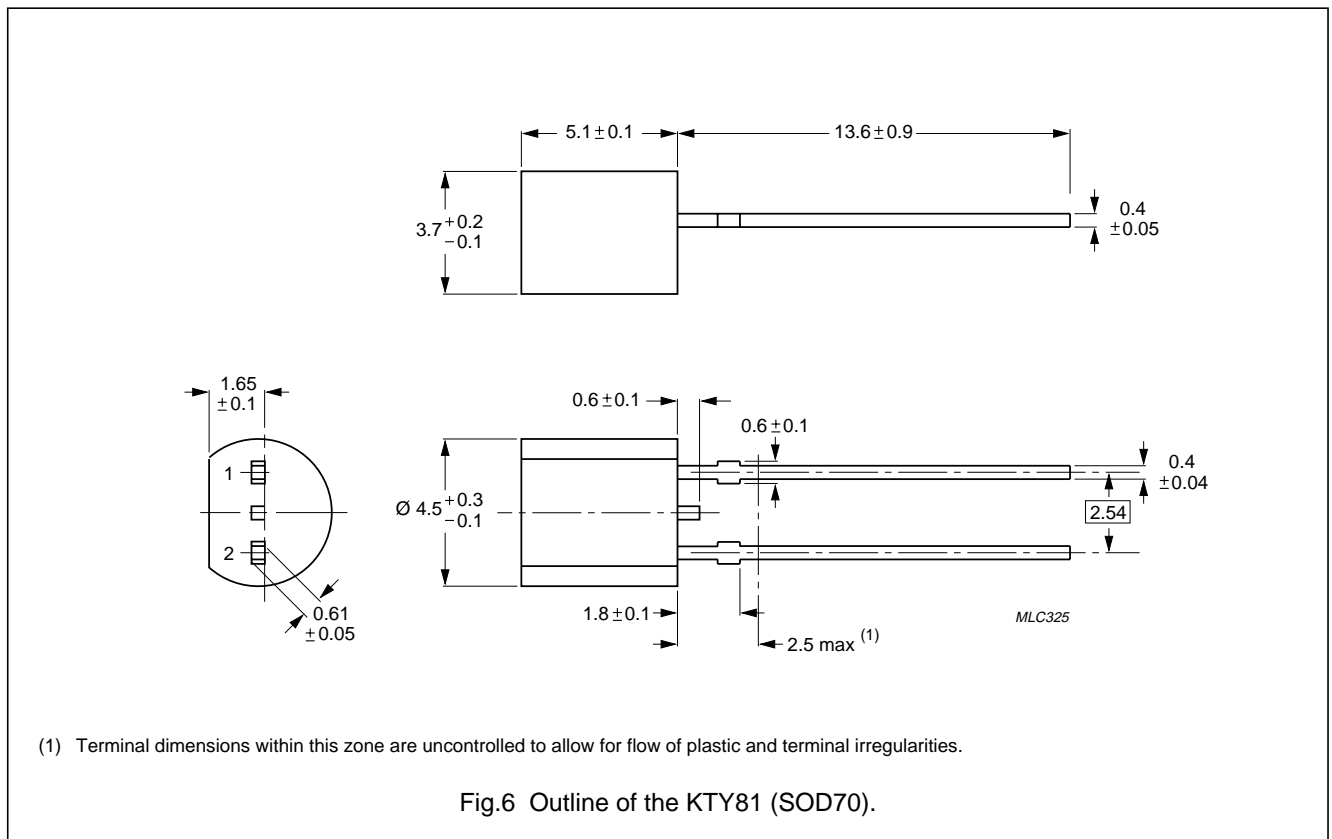

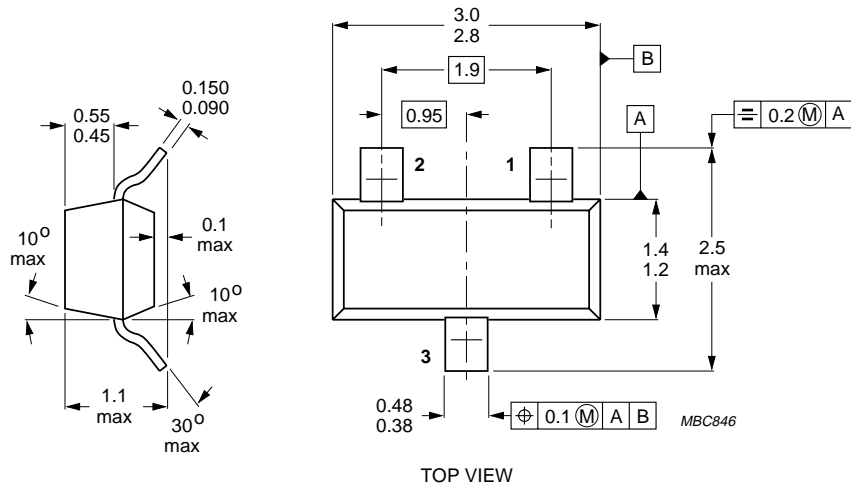
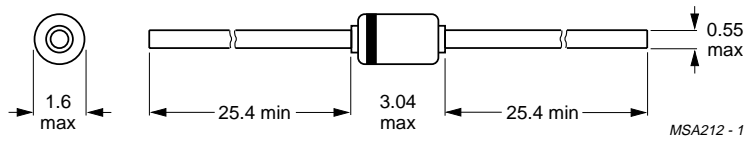
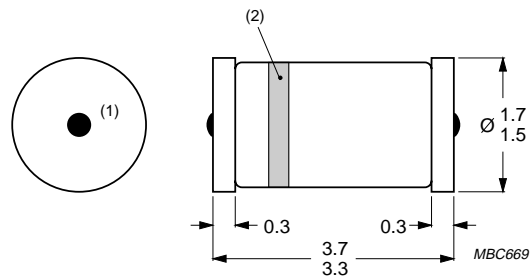

Fig.7 Outline of the KTY82 (SOT23).



The marking band indicates the negative connector.

Fig.8 Outline of the KTY83/84 (SOD68; DO34).



- (1) Area not tinned; small elevations are possible.
- (2) Indication of negative connection and product identity.

Fig.9 Outline of the KTY85 (SOD80).

Temperature sensors

General

TEMPERATURE DEPENDENCY

For the KTY83/85 series of temperature sensors, the mathematical expression for the sensor resistance ' R_T ' as a function of temperature is given by:

$$R_T = R_{ref} [1 + A (T - T_{ref}) + B (T - T_{ref})^2] \quad (1)$$

where:

R_T is resistance at temperature T

R_{ref} is the nominal resistance at the reference temperature (T_{ref})

T_{ref} is reference temperature (100 °C for the KTY84, 25 °C for all other types)

A, B are type-dependent coefficients.

For the KTY81/82/84 series, the slope of the characteristic curve decreases slightly in the upper temperature range above a certain temperature T_I (point of inflection).

Therefore, an additional term in equation (1) becomes necessary:

$$R_T = R_{ref} [1 + A (T - T_{ref}) + B (T - T_{ref})^2 - C (T - T_I)^D]$$

where:

T_I is temperature above which the slope of the characteristic curve starts to decrease (point of inflection).

C, D are type-dependent coefficients.

C is 0 for $T < T_I$.

For the types previously mentioned, the type-dependent constants 'A', 'B', 'C' and 'D', as well as ' T_I ', are given in Table 3.

For high-precision applications, e.g. microcontroller-based control systems, the above expressions and the values in Table 3 can be used to generate a calibration table to store in a ROM for look-up and linear interpolation. Data for maximum expected temperature error is supplied separately in the related data sheets. The calculations are based on both specified resistance ratios (R_{25}/R_{100} and R_{25}/R_{-55}) and the basic resistance spread at 25 °C.

If a microcontroller is not used, the slight deviation from linearity can easily be compensated using a parallel resistor (if a constant current source is used), a series resistor (if a constant voltage source is used) or a suitable combination of both. This is discussed in the Section "Linearization".

Table 3 Type dependent constants

SENSOR TYPE	A (K ⁻¹)	B (K ⁻²)	C ⁽¹⁾ (K ^{-D})	D	T _I (°C)
KTY81-1	7.874×10^{-3}	1.874×10^{-5}	3.42×10^{-8}	3.7	100
KTY81-2	7.874×10^{-3}	1.874×10^{-5}	1.096×10^{-6}	3.0	100
KTY82-1	7.874×10^{-3}	1.874×10^{-5}	3.42×10^{-8}	3.7	100
KTY82-2	7.874×10^{-3}	1.874×10^{-5}	1.096×10^{-6}	3.0	100
KTY83	7.635×10^{-3}	1.731×10^{-5}	–	–	–
KTY84	6.12×10^{-3}	1.1×10^{-5}	3.14×10^{-8}	3.6	250
KTY85	7.635×10^{-3}	1.731×10^{-5}	–	–	–

Note

1. For $T < T_I$: C = 0.

RESISTANCE/TEMPERATURE CHARACTERISTICS

Manufacturing tolerances

Silicon temperature sensors are normally produced to quite fine tolerances: ' ΔR ' between $\pm 0.5\%$ and $\pm 2\%$. Figure 10 illustrates how these tolerances are specified. The tolerance on resistance quoted in our data sheets is given by the resistance spread ' ΔR ' measured at 25 °C.

Because of spread in the slope of the resistance characteristics, ' ΔR ' will increase each side of the 25 °C point, to produce the butterfly curve shown in Fig.10. To give an indication of this spread in slope, we also quote the ratio of resistance at two other temperatures (-55 °C and 100 °C) to the nominal resistance at 25 °C, i.e. ' R_{-55}/R_{25} ' and ' R_{100}/R_{25} '; for the KTY84, we quote ' R_{25}/R_{100} ' and ' R_{250}/R_{100} '. A table giving the ΔR tolerances is included in each of the Temperature Sensor data sheets.

The user, however, is usually more interested in the maximum expected temperature error ' $\pm \Delta T$ '. We also provide this in the data sheets as a graph showing ' ΔT ' as a function of ' T '. For the high temperature sensor KTY84, we specify the resistance spread at 100 °C.

The relation between the tolerance of the resistance of the sensor and the resulting accuracy of the temperature measurement is given by the temperature coefficient, Fig.10 shows a typical situation. In the range between -40 °C and $+150$ °C the temperature coefficient varies between about 1 (-40 °C) and about 0.35 ($+150$ °C). From this graph the relation between the expected resistance tolerance and the resulting temperature error can easily be derived. The calculated maximum temperature error is given in the form of a table in every data sheet.

Current dependency of sensor resistance

The resistance of silicon temperature sensors is dependent on the operating current. In applications with an operating current deviating from the nominal current, a deviation of sensor resistance from the nominal values has to be taken into account.

For any application, an operating current ≥ 0.1 mA is recommended. For lower operating currents, the current dependency is additionally influenced by temperature.

For any application with operating currents above the nominal values, it should be noted, that an additional error caused by self-heating effects will influence the measurement accuracy.

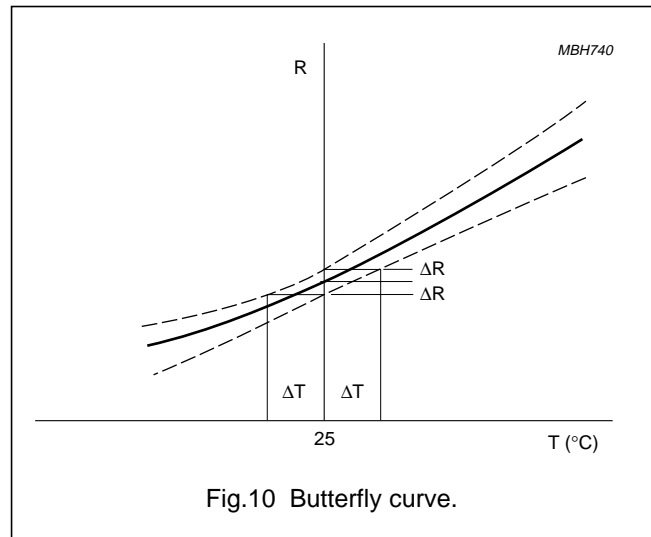

Fig.10 Butterfly curve.

Polarity of current

KTY83, 84 and 85 sensors are marked with a coloured band to indicate polarity. The published characteristics of the sensors will only be obtained if the current polarity is correct. In events where the current polarity is incorrect, the curve $R = f(T_{amb})$ differs in the upper temperature range significantly from the published form.

Note: Light, especially infrared light, also has an influence on the sensor characteristics when the current polarity is incorrect.

Linearization

The resistance/temperature characteristics of the silicon temperature sensors are nearly linear, but in some applications further linearization becomes necessary, e.g. control systems requiring high accuracy.

A simple way to do this is to shunt the sensor resistance ' R_T ' with a fixed resistor ' R_L ' (see Fig.11a). The resistance ' $R_L \times R_T / (R_L + R_T)$ ' of the parallel combination then effectively becomes a linear function of temperature, and the output voltage ' V_T ' of the linearized circuit can be used to regulate the control system.

If the circuit is powered by a constant-voltage source (see Fig.11b), a linearization resistor R_L can be connected in series with the sensor. The voltages across the sensor and across the resistor will then again be approximately linear functions of temperature.

The value of the series or parallel resistor depends on the required operating temperature range of the sensor. A method for finding this resistance is described below, giving zero temperature error at three equidistant points T_a , T_b and T_c .

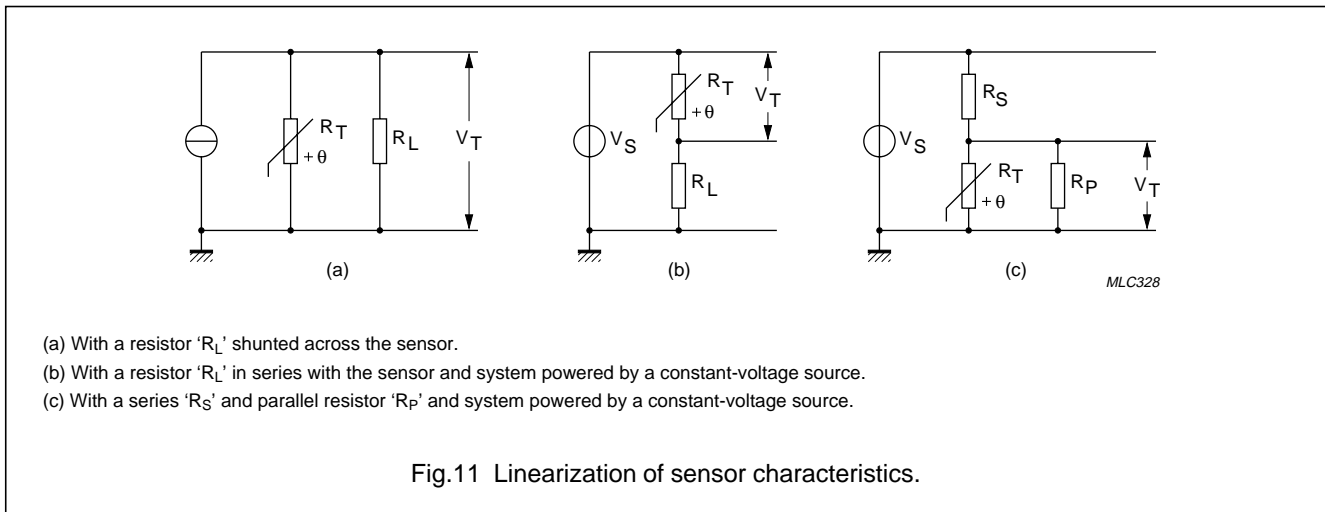

Consider the parallel arrangement. With the resistance of the sensor at three points R_a, R_b and R_c, the requirement for linearity at the three points is:

$$\frac{R_L \times R_a}{R_L + R_a} - \frac{R_L \times R_b}{R_L + R_b} = \frac{R_L \times R_b}{R_L + R_b} - \frac{R_L \times R_c}{R_L + R_c}$$

so

$$R_L = \frac{R_b \times (R_a + R_c) - 2R_a \times R_c}{R_a + R_c - 2R_b}$$

The same resistor will also be suitable for the series arrangement.

In practice, a current source is too expensive and a fixed supply voltage, e.g. 5 or 12 V is used for a specific operating current, e.g. 1 or 0.1mA. In this case, linearization can be achieved by a series/parallel resistor combination to the sensor (see Fig. 11c). The resistance of the parallel combination (R_P, R_T) and series resistor R_S is equal to the optimum linearization resistor R_L, calculated previously. Starting with the value of resistor R and with the desired current I_S through the sensor at a reference temperature T (preferably in the middle of the measured range), the resistor R_S and R_P can be calculated as follows:

$$\text{series resistor: } R_S = \frac{V_S}{I_S \times \left(\frac{R_T}{R_L} + 1 \right)}$$

$$\text{parallel resistor: } R_P = \frac{1}{\frac{1}{R_L} - \frac{1}{R_S}}$$

As an example, Fig.12 shows the deviation from linearity to be expected from a nominal KTY81 sensor, linearized over the temperature range 0 to 100 °C with a linearizing resistance of R_L = 2870 Ω.

Figure 19 shows an application example using a series/parallel combination for the KTY81 (I_S = 1 mA).

EFFECT OF TOLERANCES ON LINEARIZED SENSOR CHARACTERISTICS

In practical applications with an arbitrary sensor, the total uncertainty in the sensor reading will be a combination of spread due to manufacturing tolerances and linearization errors.

As an example, Fig.14 shows the combined effects of manufacturing tolerances and linearization errors for the KTY81 sensor linearized over the temperature range 0 to 100 °C. Calibration of the subsequent circuitry (op-amp, control circuitry, etc.) can reduce this error significantly.

Figure 15 shows the temperature error of the system with (linear) output circuitry calibrated at 50 °C, and Fig.16 shows the error of the same system calibrated at 0 and 100 °C.

Temperature sensors

General

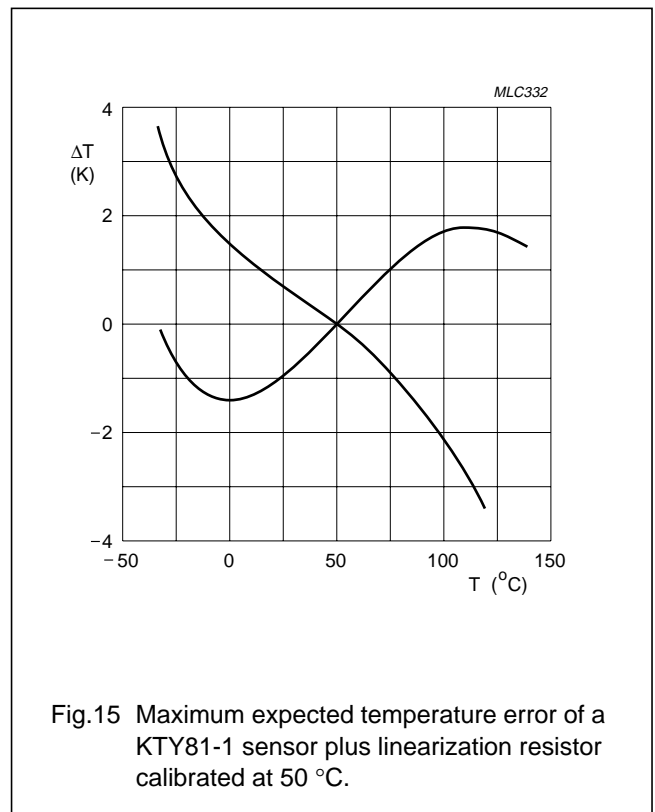
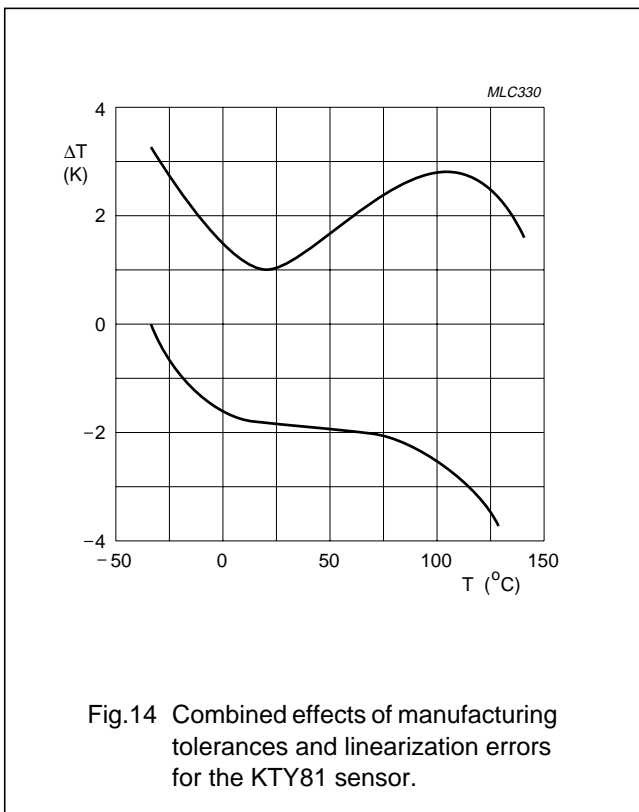
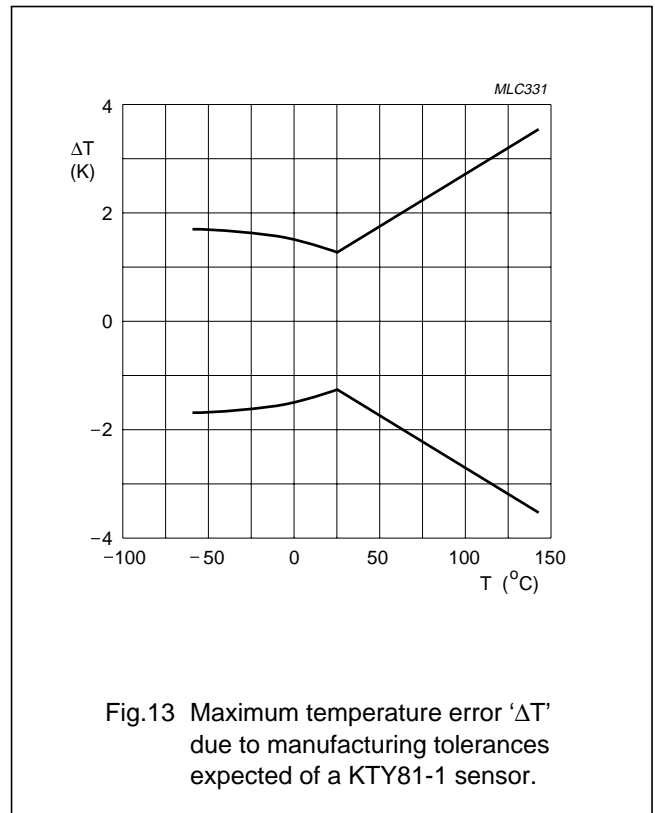
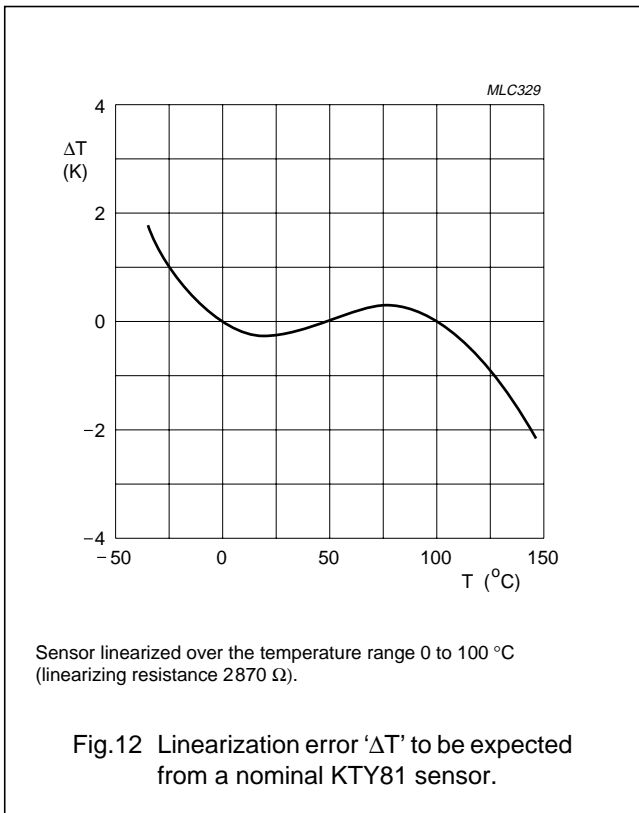

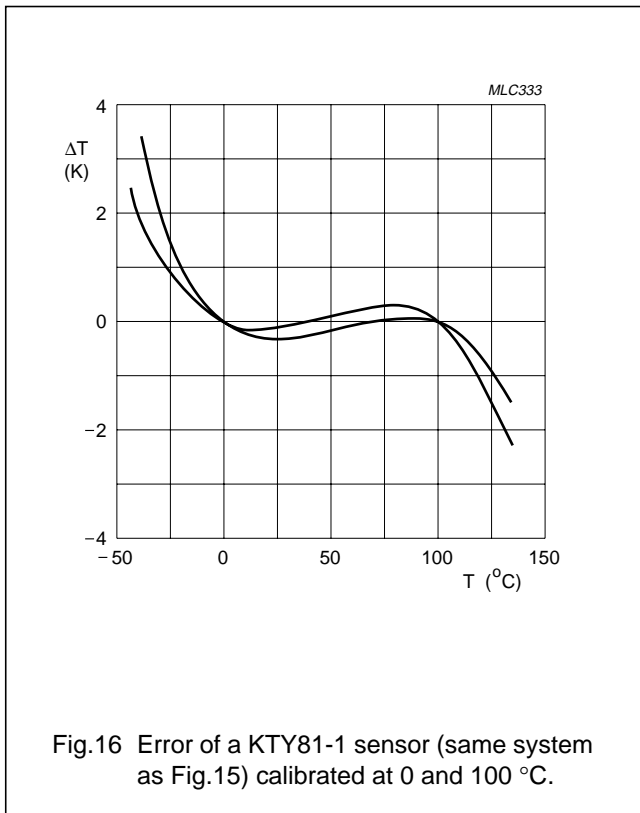

Fig.16 Error of a KTY81-1 sensor (same system as Fig.15) calibrated at 0 and 100 °C.

TEMPERATURE COMPENSATION

In many applications, it is necessary to compensate for the temperature dependency of electronic circuitry. For example, the sensitivity of many magnetic field sensors has a linear drift with temperature. To compensate for this drift, a temperature sensor with linear characteristics is required. The temperature sensors of the KTY series are well suited for this purpose and can be used for compensation of both positive and negative drift.

In many events, as with the magnetoresistive sensor KMZ10B, the temperature drift is negative. For this sensor, two circuits in SMD-technology, which include temperature compensation, are described below. The formulae given can be used to adapt the circuits to other conditions.

Figure 17 shows a simple setup using a single op-amp (NE5230D). The circuit provides the following facilities:

- Compensation of the **average** (sensor-to-sensor) sensitivity drift with temperature via a negative feedback loop incorporating a KTY82-210 silicon temperature sensor
- Offset adjustment by means of potentiometers 'R1' and 'R2'

- Gain adjustment by means of potentiometer 'R7'.

The temperature sensor is part of the amplifier's feedback loop and thus increases the amplification with increasing temperature.

With the resistor as shown in Fig.17 the temperature dependent amplification 'A' is given by:

$$A = \frac{R7}{R4 + \frac{R_B}{2}} \left(1 + 2 \frac{R_T}{R_S} \right) \tag{2}$$

and the temperature coefficient of the amplification can be calculated to be:

$$TC_A = \frac{R_T \times TC_{KTY}}{R_T + \frac{R_S}{2}}$$

with:

R_T = temperature dependent resistance of the KTY82.

TC_{KTY} = temperature coefficient of the KTY82 at reference temperature (0.79 %/K at 25 °C).

R_B = bridge resistance of the magnetoresistive sensor.

The temperature coefficient of amplification must be equal and opposite to the magnetic field sensor's 'TC' of sensitivity.

The value of the resistor 'R_S', which determines the positive 'TC' of the amplification is:

$$R_S = 2 \times R_T \left(\frac{TC_{KTY}}{TC_A} - 1 \right).$$

The resistance of the feedback resistor can be derived from equation (2):

$$R7 = R4 \times \left(\frac{A}{1 + 2 \frac{R_T}{R_S}} \right).$$

The temperature dependent values 'R_T' and 'A' are taken for a certain reference temperature, usually 25 °C, but in other applications a different reference temperature may be more suitable.

Figure 18 shows an example with a commonly used instrumentation amplifier. The circuit can be divided into two stages: a differential amplifier stage that produces a symmetrical output signal derived from the

Temperature sensors

General

magnetoresistive sensor, and an output stage that also provides a reference to ground for the amplification stage.

To compensate the negative sensor drift, the amplification is again given an equal but positive temperature coefficient by means of a KTY81-110 silicon temperature sensor in the feedback loop of the differential amplifier.

The amplification of the input stage ('OP1' and 'OP2') is given by:

$$A1 = 1 + \frac{R_T + R_B}{R_A}$$

and the amplification of the complete amplifier by:

$$A = A1 \times \frac{R14}{R10}$$

The positive temperature coefficient of the amplification is:

$$TC_A = \frac{R_T \times TC_{KTY}}{R_A + R_B + R_T}$$

For the given negative 'TC' of the magnetoresistive sensor and the required amplification of the input stage 'A1', the resistance 'R_A' and 'R_B' can be calculated by:

$$R_B = R_T \times \left(\frac{TC_{KTY}}{TC_A} \times \left(1 - \frac{1}{A1} \right) - 1 \right)$$

$$R_A = \frac{R_T + R_B}{A1 - 1}$$

The circuit provides for adjustment of gain and offset voltage of the magnetic-field sensor. The calculated resistance 'R_A' consists of the fixed resistor 'R5' and trimming resistor 'R6' provided for amplification adjustment. Amplification adjustment only negligibly influences the 'TC' of the amplifier. The output stage 'OP3' gives an output voltage of 2/5 of the supply voltage (2 V for V_S = 5 V) for zero output voltage of the magnetic field sensor and an output voltage of ±1 V for V_S = 5 V. For other supply voltages the circuit has a ratiometric behaviour.

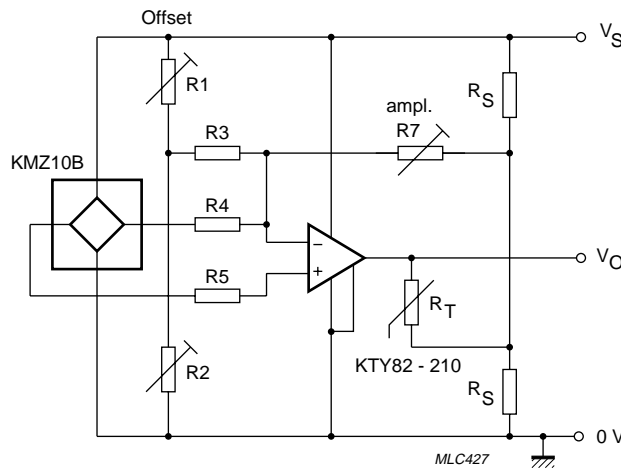

Example: A = 50 (typ.), TC_A = 0.004 K⁻¹.

Fig.17 Temperature compensation circuit.

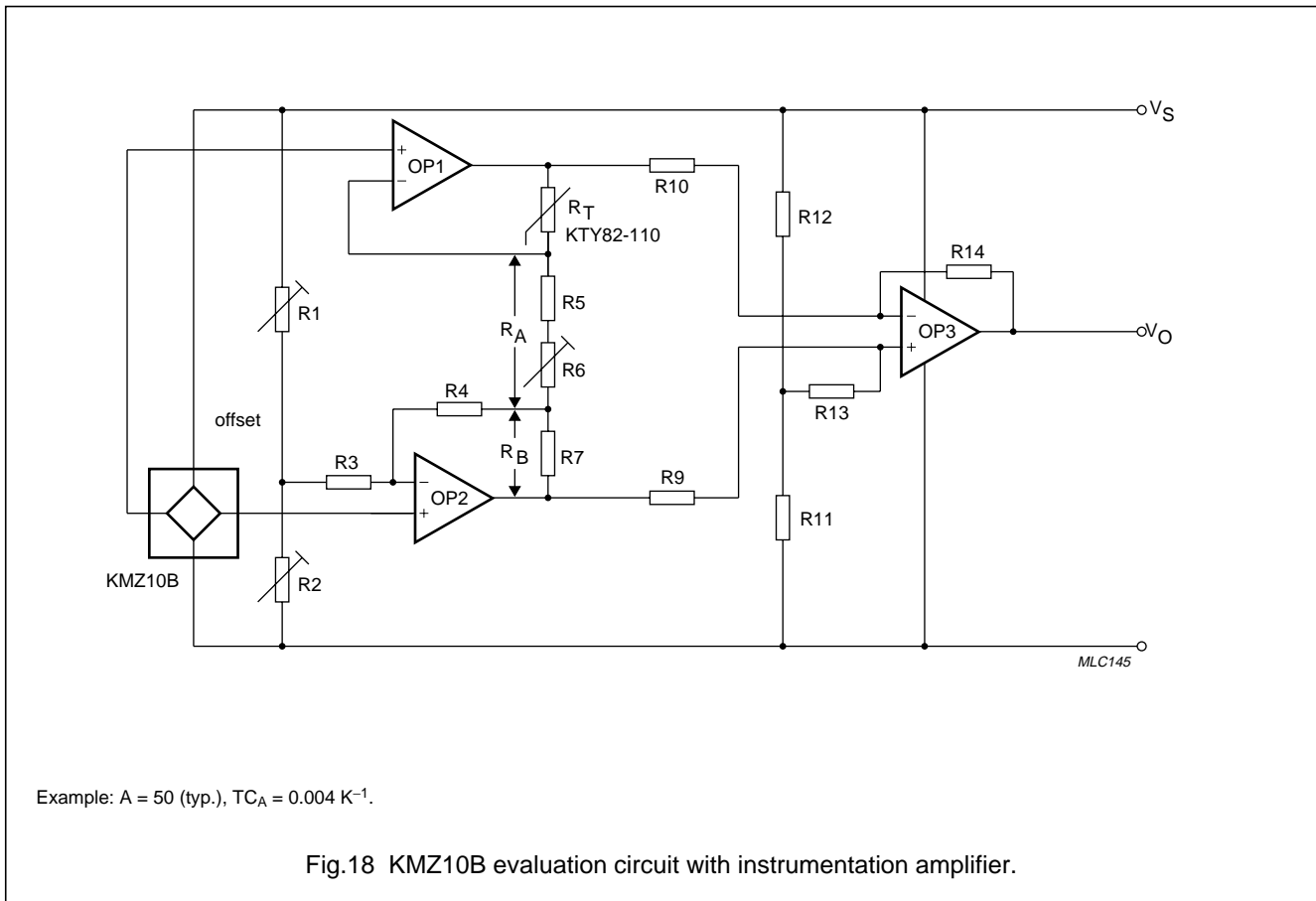

TYPICAL APPLICATION CIRCUIT

Figure 19 shows a typical and versatile temperature measuring circuit using silicon temperature sensors. This example is designed for the KTY81-110 (or the KTY82-110) and a temperature range from 0 to 100 °C.

With resistors 'R1' and 'R2', the sensor forms one arm of a bridge, the other arm being formed by resistor 'R3', potentiometer 'P1' and resistor 'R4'. The values of 'R1' and 'R2' are chosen to supply the sensor with the proper current of $\approx 1 \text{ mA}$, and to linearize the sensor characteristic over the temperature range of interest: in this event, between 0 and 100 °C. Over this temperature range, the output voltage V_O will vary linearly between $0.2V_S$ and $0.6V_S$, i.e. between 1 V and 3 V for a supply of $V_S = 5 \text{ V}$.

To calibrate the circuit, adjust 'P1' to set ' V_O ' to 1 V, with the sensor at 0 °C. Then, at a temperature of 100 °C, adjust 'P2' to set ' V_O ' to the corresponding output voltage, in this example 3 V. With this circuit, adjustment of 'P2' has no effect on the zero adjustment.

The measurement accuracy obtained by this two-point calibration is shown in Fig.16. If the application can tolerate a temperature deviation of $\pm 2 \text{ K}$ at the temperature extremes (see Fig.15), costs can be reduced by replacing 'P2' with a 1.8 k Ω fixed resistor and adjusting ' V_O ' at one temperature (the middle of the range, for example), using 'P1'.

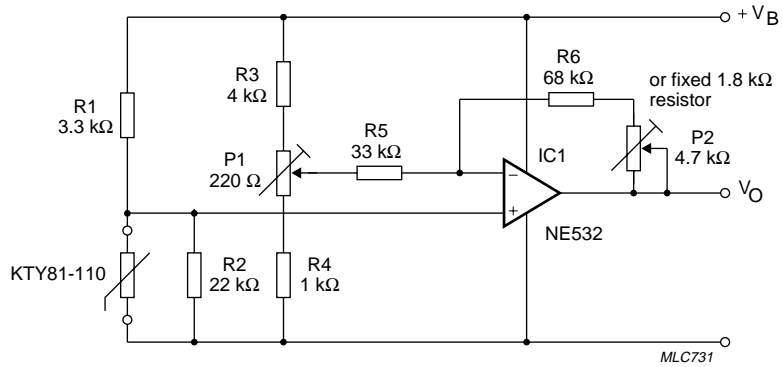

A KTY82-110 sensor would be equally suitable.
 Temperature range 0 to 100 °C; $V_O = 0.2V_S$ to $0.6V_S$.
 For $V_S = 5$ V: $V_O = 1$ to 3 V.
 All resistors metal film; tolerance $\pm 1\%$.

Fig.19 Temperature measuring circuit using a KTY81-110 sensor.

HIGH TEMPERATURE MEASUREMENT WITH KTY84

The operating range of silicon temperature sensors normally is limited to about 150 °C (an exception is the KTY83 with an upper temperature limit of 175 °C). This is due to the temperature stability of the package and the increasing intrinsic conductivity of the silicon die above 150 °C. The measuring range of the KTY84 silicon temperature sensors, however, is extended up to 300 °C.

The SOD68 (DO-34) diode housing together with special contacts between leads and sensor die give the necessary temperature resistivity for the package. The influence of the intrinsic conductivity can be suppressed by a sufficiently high operating current flowing in the correct direction.

Figure 20 shows the nominal characteristic for the recommended operating current of 2 mA and the effect of operating the sensor with a lower, and especially, a reverse current. The sensor resistance at the high temperature end makes it impossible to draw the current of 2 mA through the sensor in a common bridge circuit as in the previously suggested circuits. This is due to the usually limited supply voltage and the fact that the value of the series resistor may not be less than the linearization resistor of ≈ 5 kΩ. A solution is to supply the sensor by a constant current source.

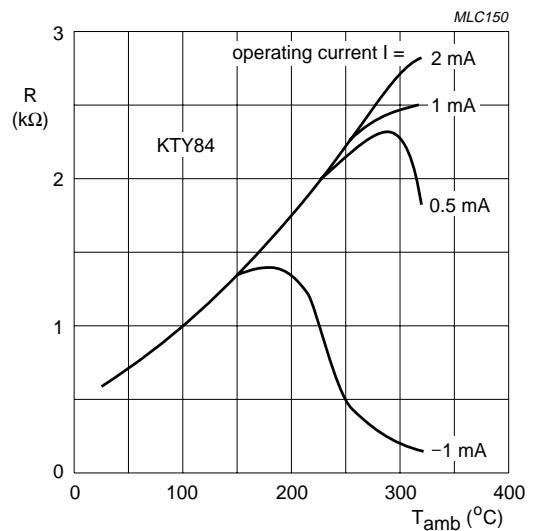

Fig.20 Sensor characteristic of the KTY84.

Temperature sensors

General

Figure 21 gives an example with internal voltage stabilization, a supply voltage of 8 to 24 V and for the full measuring range up to 300 °C. Operational amplifier 'OP1' and transistor 'TR1' form a current source to feed the temperature sensor. 'OP2' amplifies the bridge signal to the output voltage range. The circuit provides adjustment for a 'zero point'; 100 °C equals $V_O = 2\text{ V}$ ('P1'), and full range ('P2').

A second example for a KTY84 evaluation circuit takes into consideration that in some electronic systems a supply voltage of only 5 V may be used. Under such circumstances it would be impossible to obtain the

recommended current of 2 mA. A compromise is suggested by the circuit in Fig.22. A low drop current source supplies the temperature sensor and the linearization resistor. The maximum attainable current at 300 °C is 1.5 mA. This value is below the nominal operating current, but as Fig.20 shows, at up to 250 °C this will not cause any additional measuring error. Between 250 °C and 300 °C, however, a slightly decreasing slope of the sensor characteristic has to be taken into account.

The KTY84 silicon temperature sensor is a reliable and cost effective alternative to more expensive options such as Pt100-resistors or thermocouples.

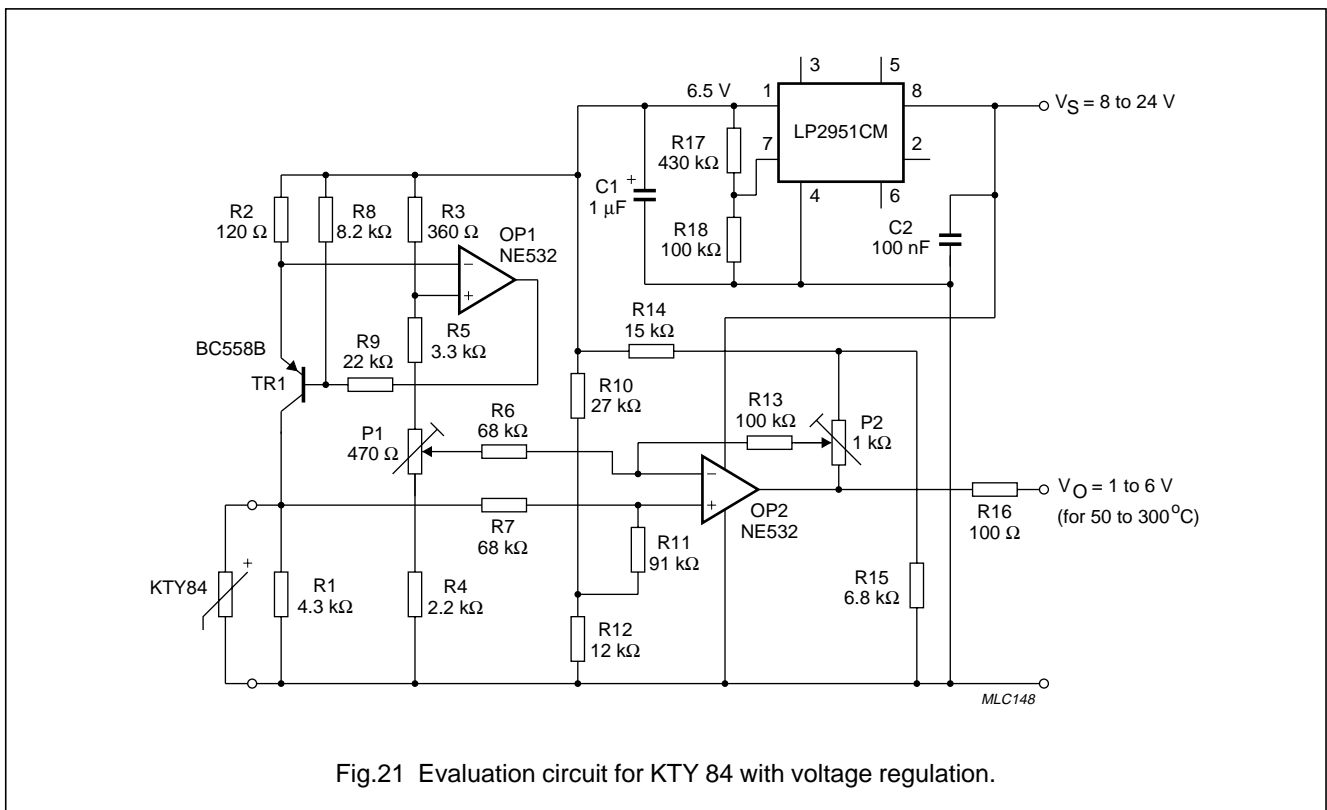
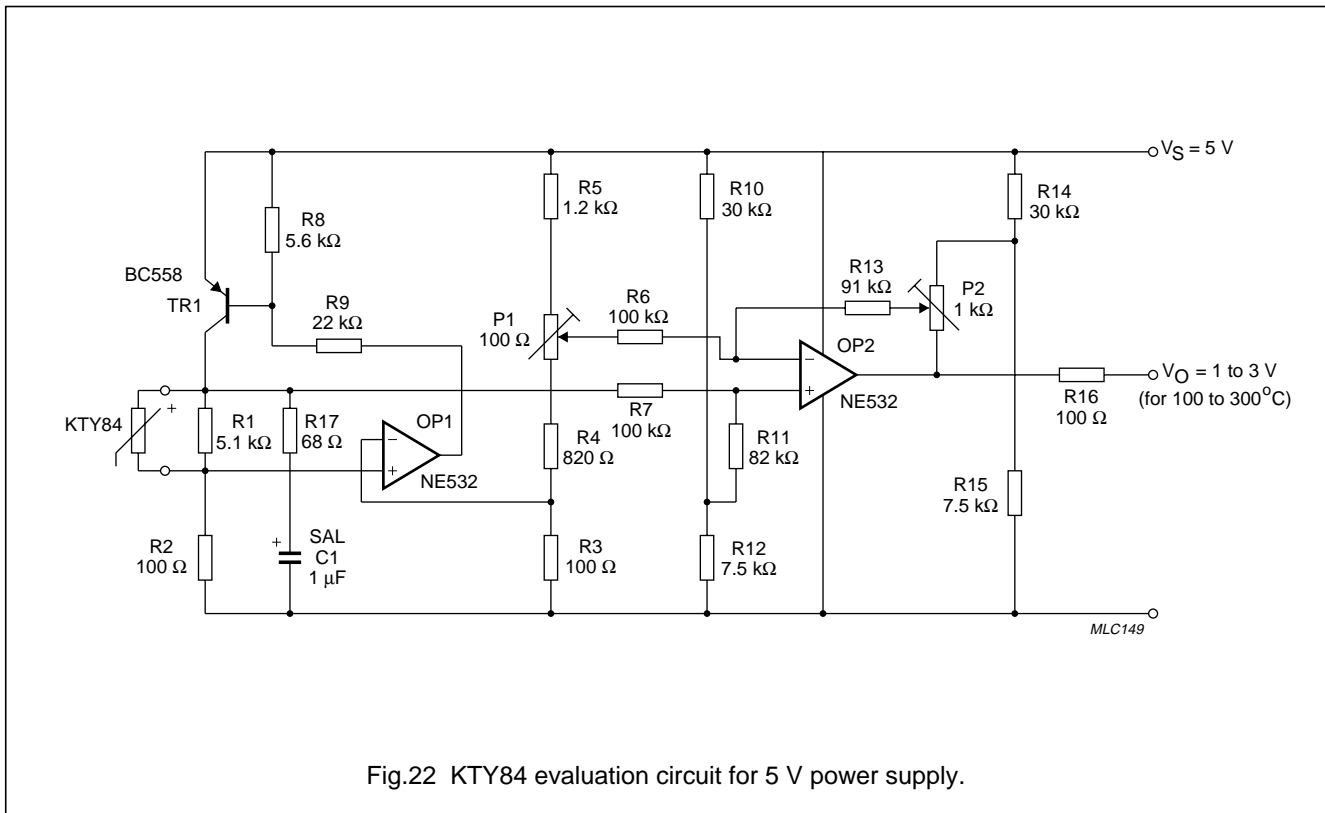

Fig.21 Evaluation circuit for KTY 84 with voltage regulation.



A/D CONVERTER TEMPERATURE COMPENSATION

When an A/D converter is integrated with a microcontroller, temperature compensation is required.

Figure 23 shows a suitable configuration, using a KTY81-210 temperature sensor in series with linearization resistor R_S . This voltage divider provides a linear temperature dependent voltage V_T of between 1.127 V and 1.886 V over the range 0 to 100 °C. This voltage is used as a reference for the A/D converter. The linear slope 'S' of $V_T = 7.59 \text{ mV/K}$.

ADDITIONAL TEMPERATURE SENSOR APPLICATIONS

Philips temperature sensors are also suitable for use in a number of other applications, for which information can be supplied on request:

- Electronic circuit protection
- Protection for power supplies
- Domestic appliances
- The white goods industry
- The automotive industry.

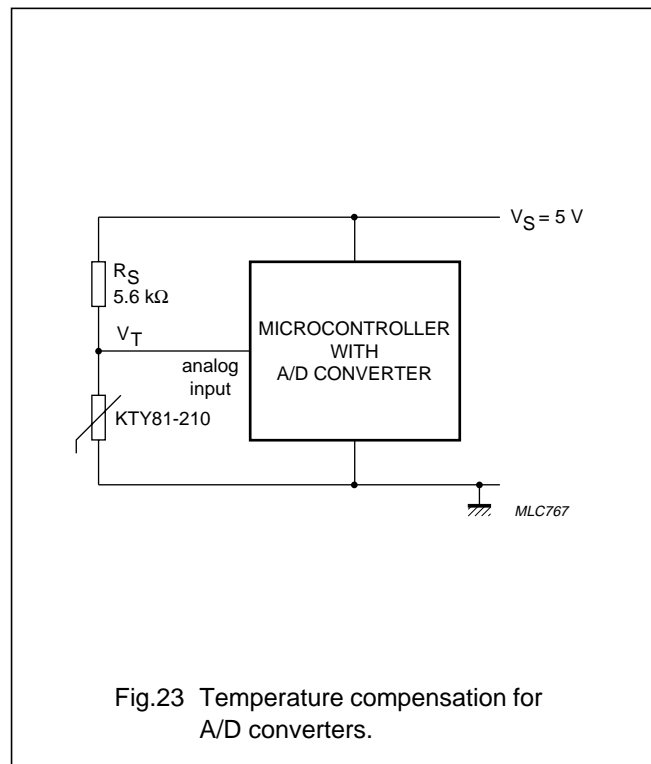

MOUNTING AND HANDLING RECOMMENDATIONS**Mounting****KTY81**

When potting techniques for KTY81 sensors are used for assembling, care has to be taken to ensure that mechanical stress and temperature development during curing of epoxy resin do not overstress the devices.

KTY83 AND 84

Excessive forces applied to a sensor may cause serious damage. To avoid this, the following recommendations should be adhered to:

- No perpendicular forces must be applied to the body
- During bending, the leads must be supported
- Bending close to the body must be done very carefully
- Axial forces to the body can influence the accuracy of the sensor and should be avoided
- These sensors can be mounted on a minimum pitch of 5 mm (2E).

Handling**ELECTROSTATIC DISCHARGE (ESD) SENSITIVITY**

Electrostatic discharges above a certain energy can lead to irreversible changes of the sensor characteristic. In extreme events, sensors can even be destroyed. In accordance with the test methods described in IEC 47 (CO)955, temperature sensors are classified as sensitive components with respect to ESD. During handling (testing, transporting, fitting), the common rules for handling of ESD sensitive components should be observed.

If necessary, the ESD sensitivity in the practical application can be further reduced by connecting a 10 nF capacitor in parallel to the sensor.

Soldering**KTY81**

The common rules for soldering components in TO-92 packages should be observed.

KTY 82

The common rules for soldering SMD components in SOT23 packages should be observed.

KTY83

Avoid any force on the body or leads during, or just after, soldering. Do not correct the position of an already soldered sensor by pushing, pulling or twisting the body. Prevent fast cooling after soldering. For hand soldering, where mounting is not on a printed-circuit board, the soldering temperature should be <300 °C, the soldering time <3 s and the distance between body and soldering point >1.5 mm. For hand soldering, dip, wave or other bath soldering, mounted on a printed-circuit board, the soldering temperature should be <300 °C, the soldering time <5 s and the distance between body and soldering point >1.5 mm.

KTY85

The common rules for surface mounted devices in SOD80 packages should be observed. Hand soldering is not recommended, because there is a great risk of damaging the glass body or the inner construction by uncontrolled temperature and time.

Welding

The KTY84 sensors are manufactured with nickel plated leads suitable for welding. The distance between the body and the welding point should be >0.5 mm. Care should be taken to ensure that welding current never passes through the sensor.

TAPE AND REEL PACKAGING

Tape and reel packaging meets the feed requirements of automatic pick and place equipment. It is also an ideal shipping container.

Table 4 Packaging quantities

TYPE	PACKAGE OUTLINE	PACKAGING METHOD	SPQ	PQ	12NC NUMBER XXXX XXX XX...
KTY81	SOD70	bulk pack	500	4000	112
		reel pack, radial	2000	10000	116
KTY82	SOT23	bulk pack	500	25000	212
		reel pack, SMD low profile 7"	3000	3000	215
		reel pack, SMD low profile 11¼"	10000	10000	235
KTY83, 84	SOD68 (DO-34)	reel pack axial 52 mm	10000	10000	113
		ammopack axial small size	1000	1000	153
KTY85	SOD80	bulk pack	1000	10000	112
		reel pack, SMD, 7"	2500	2500	115