

High Brightness LED Displays

The Power Logic Solution



Power Logic: The single chip solution

The new Power Logic STPxxC / CL596 family totally integrates all functions required to drive LEDs. These devices allow a constant current control in a monolithic solution. The external parts are reduced to only one resistor which sets the preferred maximum current for all outputs. An innovative feature of this new family is the clock and data re-synchronization; this occurs when the devices are connected in cascade.

Two different input voltages of 3.3 and 5 V and four package types simplify the design of FULL-Color and monochromatic LED panels or even for use in general applications where serial data must be transformed into LED driving.

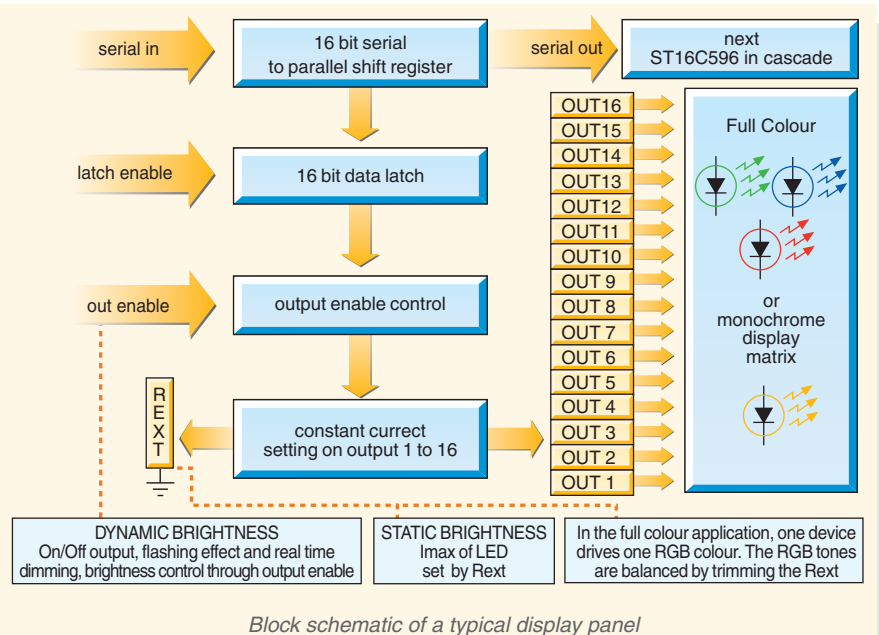
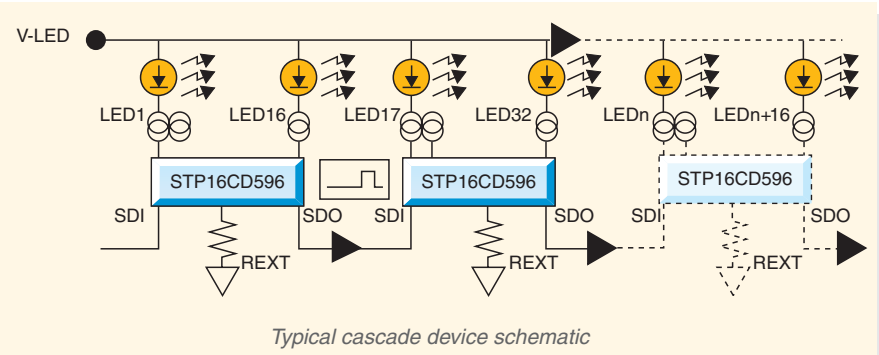

Features and Benefits

- 16 or 8 driving outputs set by only one resistor;
- 120mA full current capability at $V_O = 0.7V$;
- Serial data and clock re-synchronized device by device;
- V_{DD} 3.3 or 5 Volt;
- Packages: DIP, SO, TSSOP and TSSOP Exposed Pad, a tiny package with very high power dissipation.

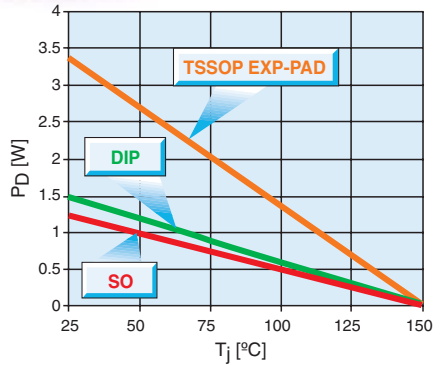
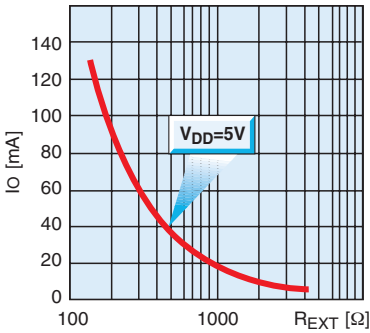

The output current is set by one external resistor

Package Power dissipation comparison

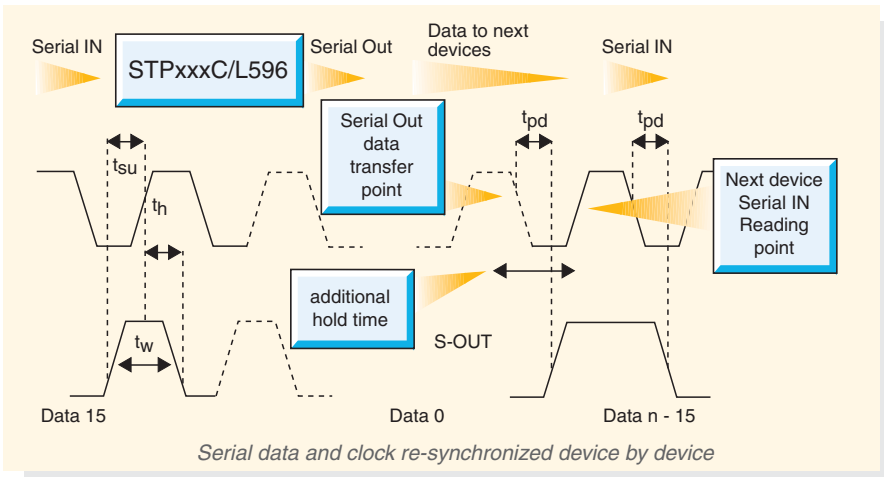

Serial data and clock re-synchronized device by device

Applications

- Signs: Full-color and monochrome displays
- Signals: Traffic displays etc.
- Automotive: Train, truck and bus exterior panels
- Display backlighting
- Specialty and illumination: Gambling machines etc.

ST's Power Logic Devices

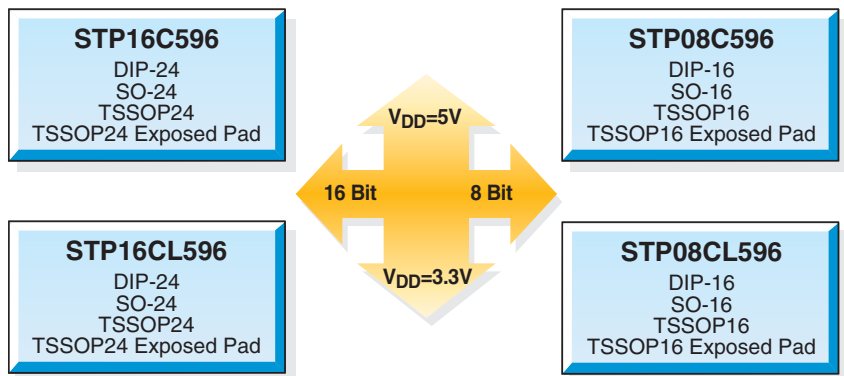

Selected Power Logic devices for HB-LED displays

P / N	V _{DD} [V]	I _O (max) [mA]	#Out	Package
STP16C / CL596B1R	5 / 3.3	120 / 90	16	DIP-24
STP16C / CL596MTR	5 / 3.3	120 / 90	16	SO-24
STP16C / CL596TTR	5 / 3.3	120 / 90	16	TSSOP24
STP16C / CL596XTTR	5 / 3.3	120 / 90	16	TSSOP24 Exp.Pad
STP08C / CL596B1R	5 / 3.3	120 / 90	8	DIP-16
STP08C / CL596MTR	5 / 3.3	120 / 90	8	SO-16
STP08C / CL596TTR	5 / 3.3	120 / 90	8	TSSOP16
STP08C / CL596XTTR	5 / 3.3	120 / 90	8	TSSOP16 Exp.Pad
STPIC6C595	5	250*	8	SO-16 TSSOP16

* Low Side Driver open drain DMOS



© STMicroelectronics - April 2004 - Printed in Italy - All rights reserved
The STMicroelectronics corporate logo is a registered trademark of the STMicroelectronics group of companies.

For selected STMicroelectronics sales offices fax:

France +33 1 55489569; Germany +49 89 4605454; Italy +39 02 8250449; Japan +81 3 57838216; Singapore +65 64815124; Sweden +46 8 58774411; Switzerland +41 22 9292900; United Kingdom and Eire +44 1628 890391; USA +1 781 861 2664

Full product information at www.st.com

