

A Review of Passive and Active Battery Balancing based on MATLAB/Simulink

Mohamed Daowd, Noshin Omar, Peter Van Den Bossche, Joeri Van Mierlo

Abstract – Battery systems are affected by many factors, a key one being the cells unbalancing. Without the balancing system, the individual cell voltages will differ over time, battery pack capacity will decrease quickly. That will result in the failure of the total battery system. Thus cell balancing acts an important role on the battery life preserving. Different cell balancing methodologies have been proposed for battery pack. This paper presents a review and comparisons between the different proposed balancing topologies for battery string based on MATLAB/Simulink® simulation. The comparison has been carried out according to circuit design, balancing simulation, voltage/current stress, practical implementations, application, balancing speed, complexity, balancing system efficiency, size, cost ... etc. **Copyright© 2011 Praise Worthy Prize S.r.l. - All rights reserved.**

Keywords – Battery balancing review, Cell equalization, MATLAB/Simulink simulation, Battery management system.

Abbreviations or Glossary:

C	Battery Capacity, in ampere-hours [Ah]
DTSC	Double-Tiered Switched Capacitor balancing
EV	Electric Vehicle
EPNGV	Extended Partnership for a New Generation of Vehicles
HEV	Hybrid Electric Vehicle
ICE	Individual Cell Equalizer
Li-ion	Lithium-Ion
Li-Po	Lithium-Polymer
MSC	Modularized Switched Capacitor balancing
MSI	Multi-Switched Inductor balancing
MpT	Multiple Transformer balancing
MWT	Multi-Winding Transformer balancing
PWM	Pulse Width Modulation
SC	Switched Capacitor balancing
SoC	State of charge [%]
SoH	State of Health [%]
SR	Switched Resistor balancing
SSC	Single Switched Capacitor balancing
SSI	Single Switched Inductor balancing
ST	Shared Transformer balancing
SWT	Single Winding Transformer balancing

I. Introduction

BATTERY management system (BMS) is an important part of the electric vehicle (EV). It protects the battery system from damage, predicts and increases battery life, and maintains the battery system in an accurate and reliable operational condition. The BMS performs several tasks such as measuring the system voltage, current and temperature, the cells' state of charge (SoC), state of health (SoH), and remaining

useful life (RUL) determination, protecting the cells, thermal management, controlling the charge/discharge procedure, data acquisition, communication with on-board and off-board modules, monitoring, storing historical data and - most importantly – cell balancing.

Imbalance of cells in battery systems is an essential factor in the battery system life. Without the balancing system, the individual cell voltages will drift apart over time. The capacity of the total pack will also decrease more quickly during operation and the battery system will fail prematurely [1]. Quite a lot of cell balancing/equalization methods have been proposed such [1-35] and reviewed in [1-6].

The cells imbalance is caused by internal and external sources according to [35]. Internal sources include manufacturing variance in charge storage volume, variations in internal impedance and differences in self-discharge rate. External sources are mainly caused by some multi-rank pack protection ICs, which drain charge unequally from the different series ranks in the pack. In addition the thermal difference across the pack results in different self discharge rates of the cells.

The balancing topologies can categories as passive and active balancing as shown in Fig. 1. The passive balancing methods removing the excess charge from the fully charged cell(s) through passive, resistor, element until the charge matches those of the lower cells in the pack or charge reference. The resistor element will be either in fixed mode as [6-7] or switched according the system as [1-6], [8-10].

The active cell balancing methods remove charge from higher energy cell(s) and deliver it to lower energy cell(s). Different topologies are used according to the

active element used for storing the energy such as capacitor and/or inductive component as well as controlling switches or converters as [1-6] and [10-35].

This paper discusses the several proposed balancing methods from different viewpoints and simulates some

balancing methods using MATLAB/Simulink. Different balancing topologies are compared based on circuit design, application, implementations, balancing speed, complexity, size, balancing system efficiency, cost ... etc.

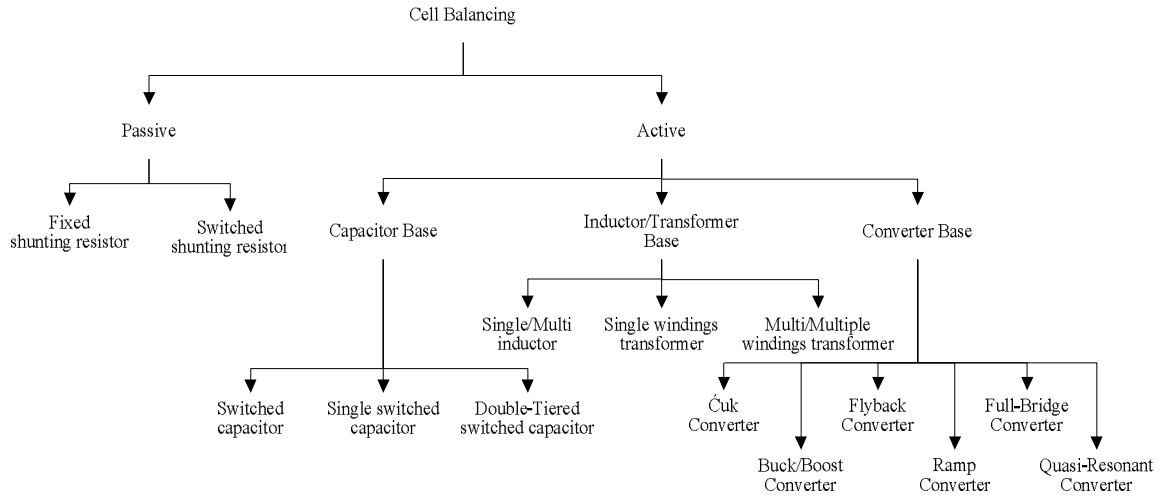

Fig. 1. Passive and active cell balancing topologies.

II. Shunting Resistor Balancing

Shunting resistor cell balancing methods are the most straightforward equalization concept. They are based on removing the excess energy from the higher voltage cell(s) by bypassing the current of the highest cell(s) and wait to until the lower voltage cell(s) to be in the same level. The shunting resistor methods can be categorized into two sub-categories as shown in Fig. 2.

The first method is fixed shunt resistor (FR) as presented in [6-7], as shown in Fig. 2-a. This method uses continuous bypassing the current for the all cells and the resistor is adjusted to limit the cells voltage. It can be only used for Lead-acid and Nickel based batteries because they can be brought into overcharge conditions without cell damage [4]. Its features are simplicity, low cost but it has continuous energy dissipated as heat for all cells.

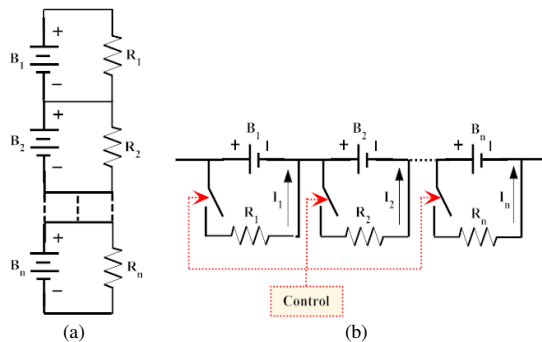

Fig. 2. Shunting resistor a) fixed resistor, and b) switched resistor.

The second method is controlled shunting resistor or switched shunt resistor (SR) [8-9], is shown in Fig. 2-b. It is based on removing the energy from the higher cell(s) not continuously but in a controlled way using switches/relays. It could work in two modes. First, the continuous mode, where all relays are controlled by the same on/off signal. Second, detecting mode, where the cells voltages are monitored. When the imbalance conditions are sensed, it decides which resistor should be shunted. This method is more efficient than the fixed resistor method, simple, reliable and can be used for the Li-Ion batteries.

The main drawback in these methods the excess energy from the higher cell(s) is dissipated as heat, there is a need for thermal management, and if applied during discharge will shorten the battery's run time. The two methods can be implemented for the low power applications with dissipating current smaller than 10mA/Ah as recommended in [4].

III. Capacitive shuttling balancing methods.

Capacitive cell balancing, also known as "Charge Shuttling" equalization, [11-17] utilizes capacitors as external energy storage devices for shuttling the energy between the pack cells so as to do the balancing. The capacitive shuttling can be categorized into three shuttling topologies; the basic switched capacitor (SC), single switched capacitor (SSC) and double-tiered switched capacitor (DTSC) topologies (Fig. 1).

III.1. Switched Capacitor

The switched capacitor (SC) cell balancing [1-5], [11-12] is shown in Fig. 3. As illustrated it requires $n-1$ capacitors and $2n$ switches to balance n cells. Its control strategy is simple because it has only two states. In addition, it does not need intelligent control and it can work in both recharging and discharging operation. The disadvantage of the switched capacitor topology is its relatively long equalization time.

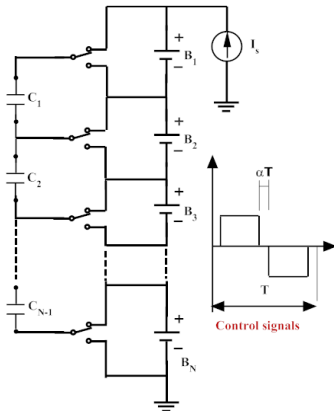

Fig. 3. Switched capacitor balancing topology.

III.2 Single Switched Capacitor

The single switched capacitor (SSC) balancing topology [1], [4-5], [13] can consider as a derivation of the Switched Capacitor, but it uses only one capacitor as shown Fig. 4. The Single Switched Capacitor needs only one capacitor and $n+5$ switches to balance n cells.

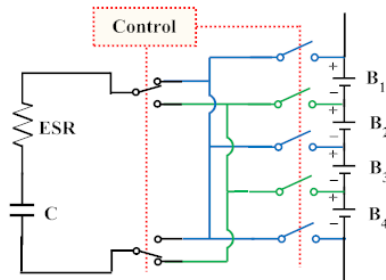

Fig. 4. Single switched capacitor cell balancing.

A simple control strategy is used; the controller selects the higher and the lower cell and the corresponding switches for shuttling the energy between them. However, more advanced control strategies can be used to increase the balancing speed.

III.3 Double-Tiered Switched Capacitor

Double-tiered switched capacitor (DTSC) balancing method [14-15] is also a derivation of the switched capacitor method, the difference is that it uses two capacitor tiers for energy shuttling as shown Fig. 5. It needs n capacitors and $2n$ switches to balance n cells.

The advantage of double-tiered switched capacitor is that the second capacitor tier reduces the balancing time to a quarter of the time needed for the switched capacitor method. In addition, the capacitor-based topologies can work in both recharging and discharging operation.

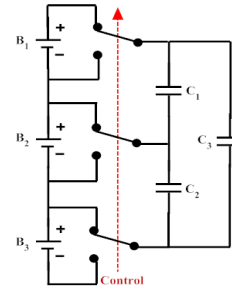

Fig. 5. Double-tiered switched capacitor cell balancing topology.

Another topology utilizes the switched capacitor method is based on battery modularization [16] shown in Fig. 6. It utilizes the modules technique by dividing the battery pack into modules; inside each module it treats with sub-module cells with a separate equalization system. Another equalization system between the modules reduces the switches' voltage and the current stress.

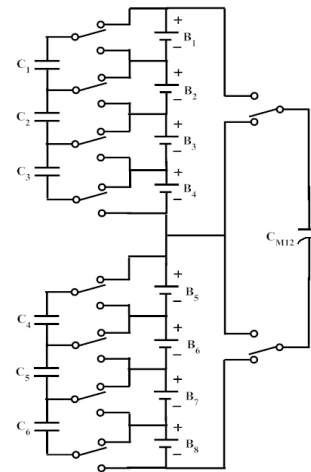

Fig. 6. Modularized switched capacitor (MSC) balancing [16].

IV. Inductor/transformer balancing methods.

Energy conversion cell balancing topologies using inductors or transformers to move energy from a cell or group of cells to another cell or group of cells are proposed in [17-24]. Because of relative high balancing current they offer a smaller balancing executing time; their disadvantage is the relatively high cost, and magnetic losses for the transformers. In addition, since the switching frequency is quite high, filter capacitors must be placed across each battery to filter the high frequency [6].

IV.1 Single/Multi switched Inductor

The use of one or more inductors for cell balancing [17-19] is shown in Fig. 7. The single switched inductor (SSI) balancing system, shown in Fig. 7-a proposed in [18], utilizes one inductor for transferring energy between the whole pack. The control system senses the voltage of the cells and selects the two cells which will be used for energy transferring. The multi switched inductor (MSI) balancing system [17], [19], uses $n-1$ inductor for balancing n cells (see Fig. 7-b) and the controller senses the voltage difference of the two neighboring cells, then applying a PWM with a condition that the higher cell must be switched on at first. They are feature by fast equalization time. The main disadvantage in MSI, it takes a relatively long time for transferring the energy from the first cell to the last one especially for long string battery pack. SSI has less equalization time than the MSI topology.

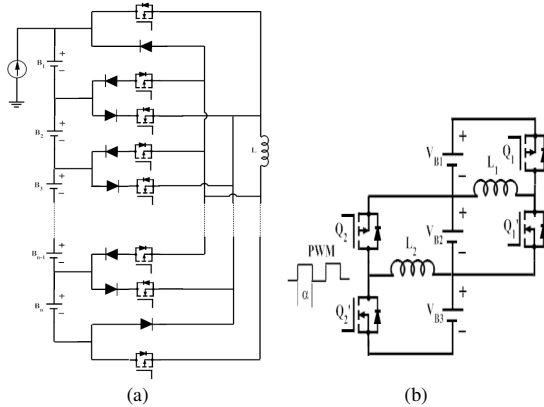

Fig. 7. Single/Multi inductor battery balancing topologies a) single-inductor and b) multi-inductor.

IV.2 Single-Winding Transformer

The single winding transformer (SWT) as well, known as “switched transformer, ST” [1-4], [10], [20-21], is actually a selectable energy converter [4]. This method has two techniques for cell balancing. First technique “pack-to-cell topology” as shown in Fig. 8, is based on carrying the energy from the whole battery pack through the switching transformer and transferring that energy to the weak cell(s) using the corresponding switch(s).

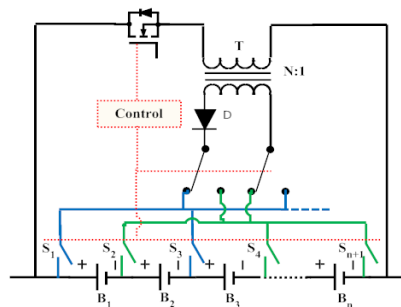

Fig. 8. Single windings transformer balancing topology.

The second technique “cell-to-pack topology” is based on transferring the energy from the high energy cell(s) through the transformer into the battery pack as proposed in [20].

IV.3 Multi-Windings Transformer

The multi-windings transformer (MWT) balancing topology [1-4], [10], [22-23] is shown in Fig. 9. Two topologies can be used: the first multi-windings transformer, shown in Fig. 9, is known as “shared transformer”. The second one is multiple transformers (MpT) balancing which is shown in Fig. 10.

The multi-windings transformer “shared transformer” topology [1-4], [22-23] has a single magnetic core with one primary winding and multiple secondary windings one for each cell. It has two circuit configurations [3]; flyback and forward configurations, as shown in Fig. 9.

The flyback structure, the switch connected to the primary side is switched on. So, some energy is stored in the transformer. Then when it is switched off, the energy is transferred to the secondary of the transformer. Most of the induced current will be provided to the cell(s) with lowest voltage via the diode(s).

In the forward structure, when the voltage difference is detected, the switch connected to the cell with highest voltage is switched on, and energy is transferred from this cell to others via the transformer and the anti-parallel diodes of the switch. The circuit is complex and the cost is high, there is also the saturation problem.

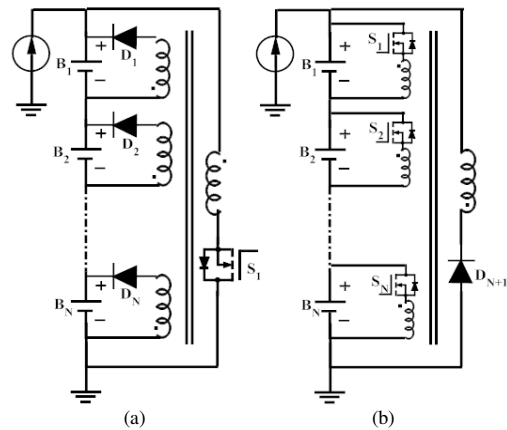

Fig. 9. Multi-secondary windings transformer a) flyback structure b) forward structure [3].

The second topology, the multiple transformer balancing as in [1-4], [10] is shown in Fig. 10, uses several multiple core transformers, one core for each cell. Compared to the multi-windings transformer scheme, this method is better for modular design and battery pack extension without changing the magnetic core, while it is still expensive.

Inductor/transformer balancing systems can also be used in a modular way just as with the switched capacitor method [16], [24].

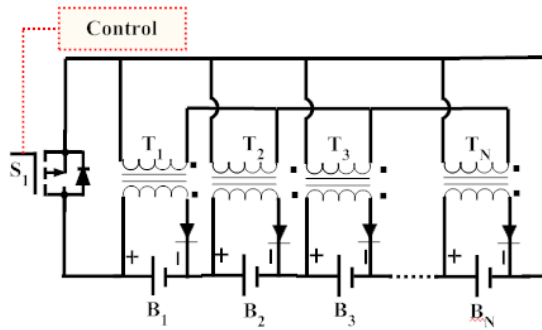

Fig. 10. Multiple transformer balancing topology.

Modular inductor/transformer utilizes the modules technique by dividing the battery pack into groups or modules that will reduce the voltage and/or the current stress in the switching components.

V. Energy converter balancing methods.

Energy converters [25-33] used for cell balancing fall in several categories such as; Ćuk, Buck or/and Boost, Flyback, Ramp, full-bridge and, Quasi-Resonant converters. They are featured by fully control of balancing process. Unfortunately, the system is facing its relatively high cost and complexity.

V.1 Ćuk converter

The bi-directional Ćuk converter [25], [26] as shown in Fig. 11 can be considered as an individual cell equalizer (ICE) topology, which balances each pair of the neighboring cells. It requires $n-1$ ICEs circuit to balancing n cells. Each ICE circuit has two inductors, two switches and one capacitor. Since the Ćuk converter transfer the energy between two neighboring cells so it will take a relatively long equalization time especially for long string battery packs.

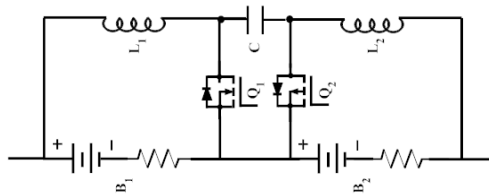

Fig. 11. Ćuk converter balancing topology.

V.2 Buck or/and Boost converter

Step down (Buck), step-up (Boost) and Buck-Boost d.c energy converters [1-3], [27-28] are widely used in cell balancing systems. These methods have several balancing topologies such as buck d.c converter shown in Fig. 12 used for transferring energy from a source or the battery pack to weak cell(s), boost converter used for removing the excess energy from a single cell to the total pack, or buck-boost converter shown in Fig. 13 can be used for removing excess energy from the highest

cells to the DC link, storage element, or EV auxiliary battery, and retransfer the energy to the weak cell(s). The cells' voltage sensing as well as an intelligent controller are needed for the converters operation. Converters balancing methods are relatively expensive and complex but they are suitable for modular design with their high efficiency.

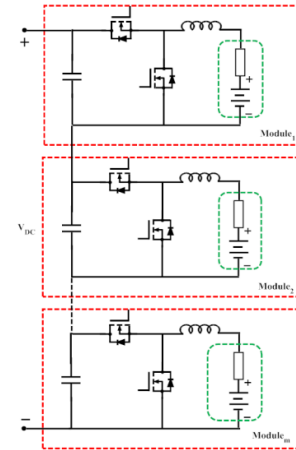

Fig. 12. Buck energy converters (BC) cell balancing topology.

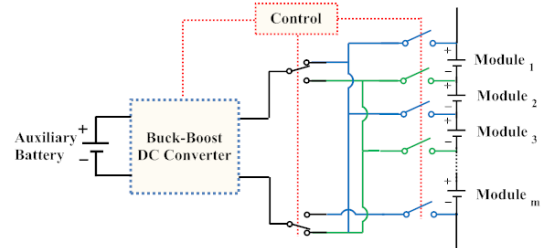

Fig. 13. Buck-boost d.c converters (BBC) cell balancing topology.

V.3 Flyback converter

Flyback converters (FbC) [1], [3], [29-30] are used in isolated structure and they can be unidirectional or bi-directional, as shown in Fig. 14. In the unidirectional structure, energy of the more charged cell is stored in the transformer when the coupled switch is on and transferred to the pack when it is off. The bidirectional flyback converter is more flexible in energy transmission since the energy also can be transferred from the pack to the cells. Drawbacks are the uniformity of the multi winding as well the magnetic losses.

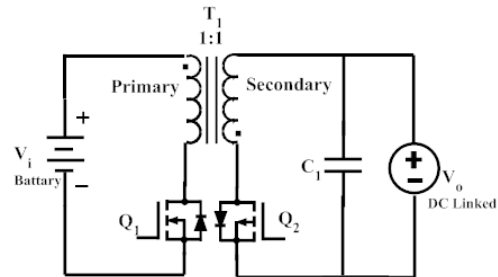

Fig. 14. Flyback energy converter battery balancing.

V.4 Ramp converter

Ramp converter (RC) cell balancing topology [1], [2], [34] shown in Fig. 15 shares the same idea as multi-windings transformers. It only requires one secondary winding for each pair of cells instead of one per cell. The ramp converter operation can be summarized as follows: on the first half cycle, most of the current is used to charge the odd number of lowest voltage cells. While on the other half cycle it supplies the even cells, so that it is called ramp converter.

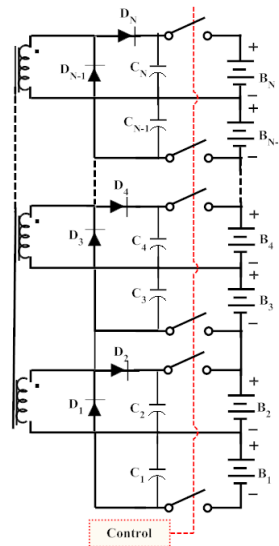

Fig. 15. Ramp converter cell balancing topology.

V.5 Full-bridge converter

The full-bridge PWM energy converter [33] can be considered as a fully controlled energy converter and is shown in Fig. 16. It can be used in a.c./d.c. mode which is suitable for the plug-in hybrid electric vehicle (PHEV) or as d.c./d.c. converter. Both need an intelligent control and are superior for modulated battery packs and high power rating. The main drawback of Full-bridge converter is its relatively high cost and complex control.

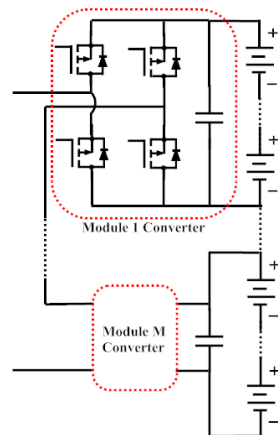

Fig. 16. Full-bridge energy converter cell balancing topologies.

V.6 Quasi-Resonant converter

The quasi-resonant converter [1], [2], [31-32] shown in Fig. 17, can be either zero-current quasi-resonant (ZCQR) or zero-voltage quasi-resonant (ZVQR) converters. Instead of using intelligent control to generate a PWM signal, resonance circuits are used for both transferring energy and driving the switches. L_r and C_r are constructed as the resonant tank to achieve the zero current switching function for the symmetrical and bi-directional battery equalizer.

The main advantage of the resonant converters is that they can reduce the switching losses thus increasing the balancing system efficiency. Unfortunately, the resonant converters have a very complex control, difficult implementation, as well high converter cost.

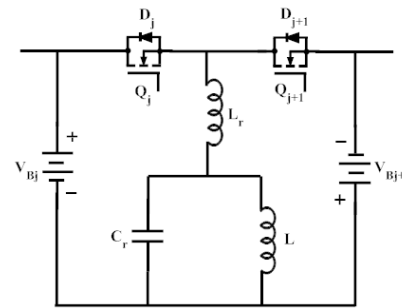

Fig. 17. Zero-current quasi-resonant converter balancing topologies.

VI. Balancing Topologies Simulation Results and Comparative Analysis.

MATLAB/Simulink has become the most used software for modelling and simulation of the dynamic systems. To simulate the cell balancing system, a cell battery model is first needed. Lithium polymer (Li-Po) batteries have been tested and their parameters estimated according to [36], a complete battery model has been drafted by the "Extended partnership for a new generation of vehicles EPNGV" [37]. This battery model features SoC, SoH and cycle number prediction, variable parameters in function of SoC, temperature and cycle number with parameters variations between cells.

For this paper, different battery balancing systems have been simulated using Simulink such as, fixed resistor, shunting switched resistor, switched capacitor, single switched capacitor, double-tiered switched capacitor, single switched inductor, multi switched inductor, single-windings transformer and buck-boost d.c converter coupled to the vehicle auxiliary battery. As well as the control system for the premonition balancing systems is planned.

The battery balancing system simulation has been performed on a battery pack of four 12 Ah lithium polymer cells with initial SoC of 80, 78, 76 and 74%, a realistic spread. In addition the cells have different internal resistance. The following figures illustrate various balancing topologies simulation results.

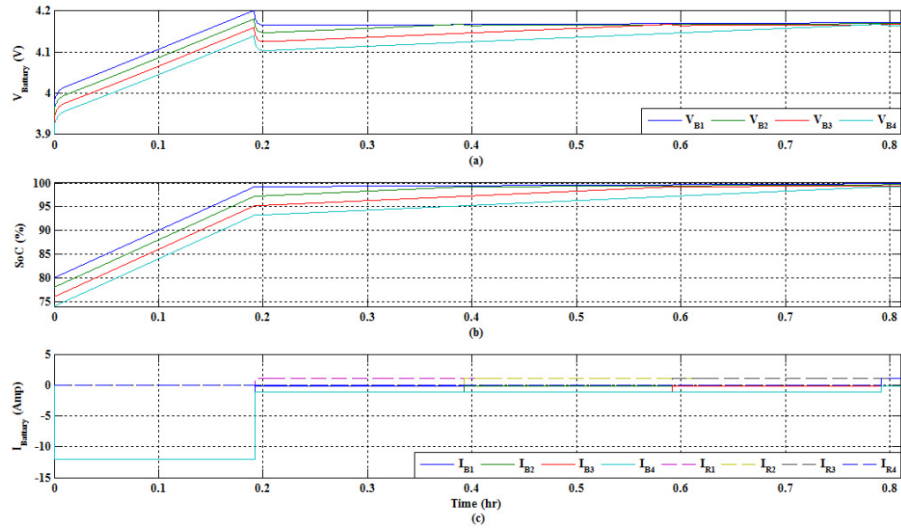

Fig. 18. Switched shunt resistor balancing a) cells voltage, b) cells SoC and c) cells and the resistors currents.

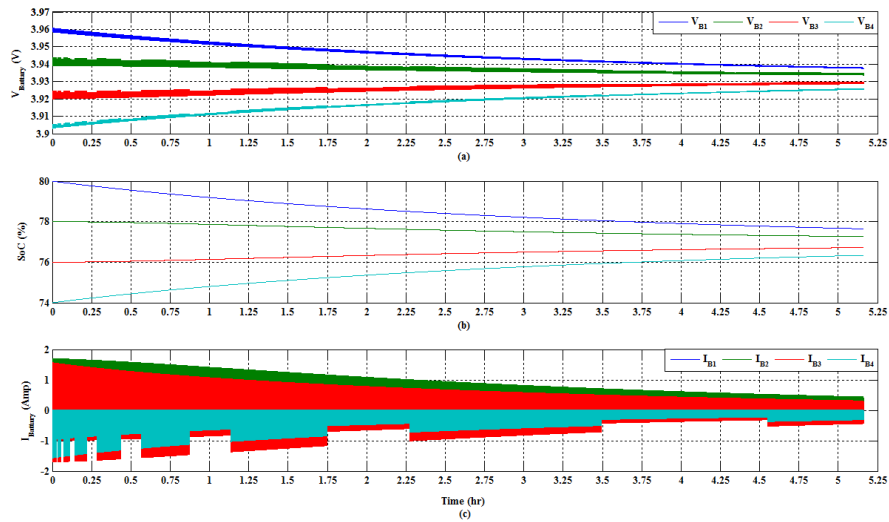

Fig. 19. Switched capacitor balancing a) cells and capacitor voltages, b) cells SoC and c) cells currents.

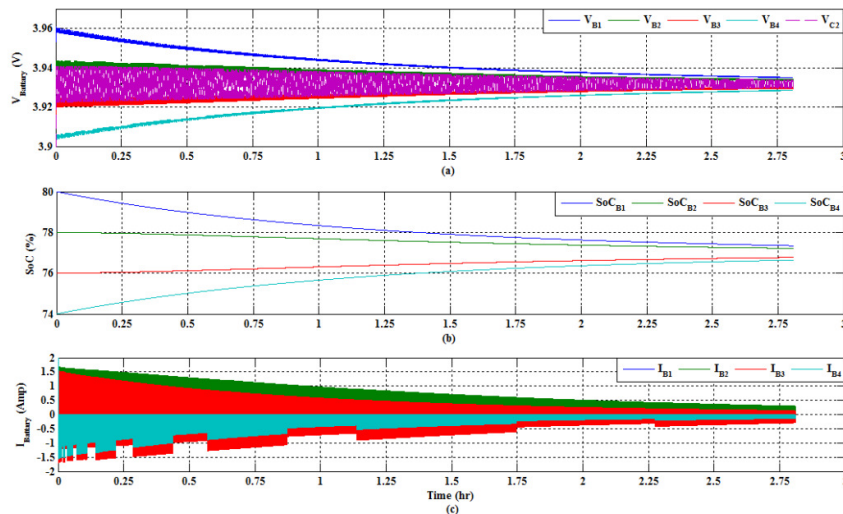

Fig. 20. Double-tiered single switched capacitor balancing a) cells and capacitor 2 voltages, b) cells SoC, and c) cells currents.

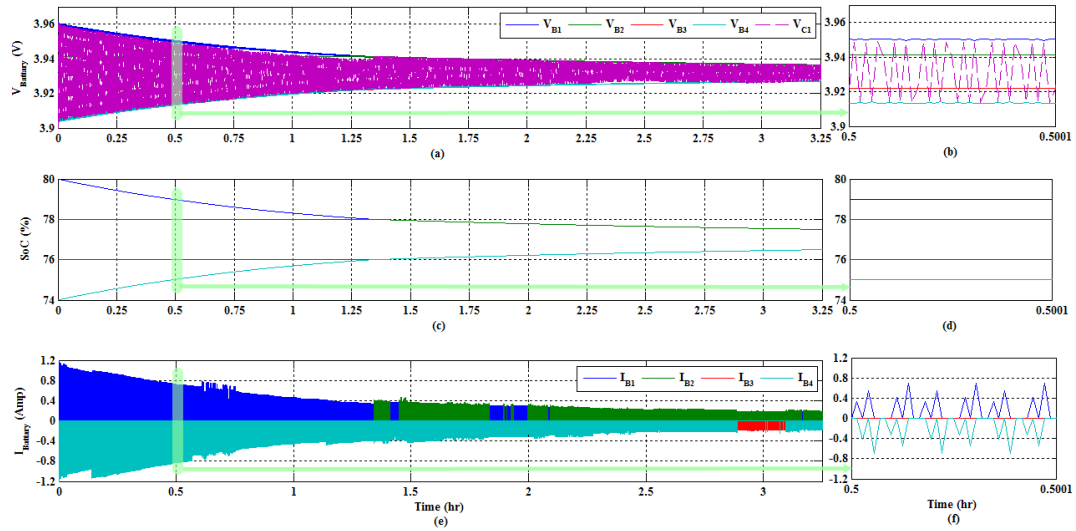

Fig. 21. Single switched capacitor a) cells and capacitor voltages, b) voltages zoom, c) cells SoC, d) SoC zoom, e) cells currents, f) current zoom.

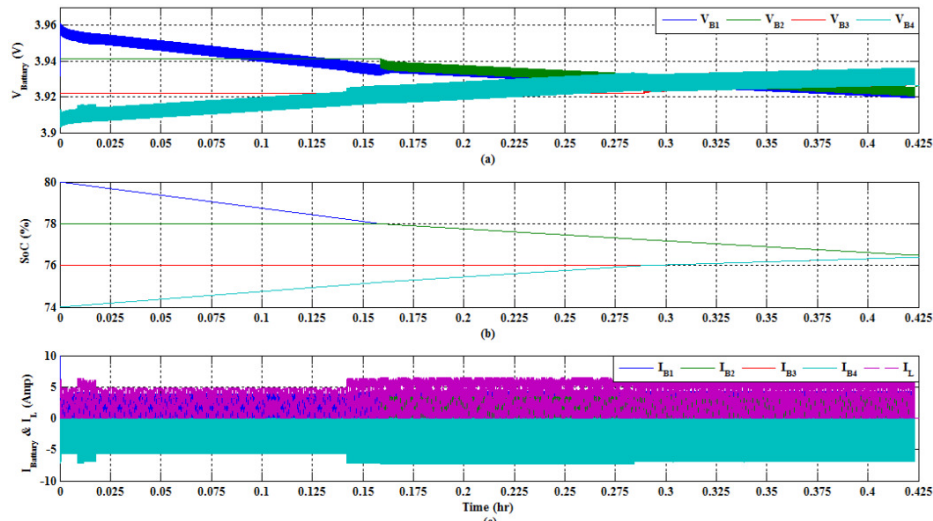

Fig. 22. Single switched Inductor balancing a) cells voltage, b) cells SoC and c) cells and Inductor currents.

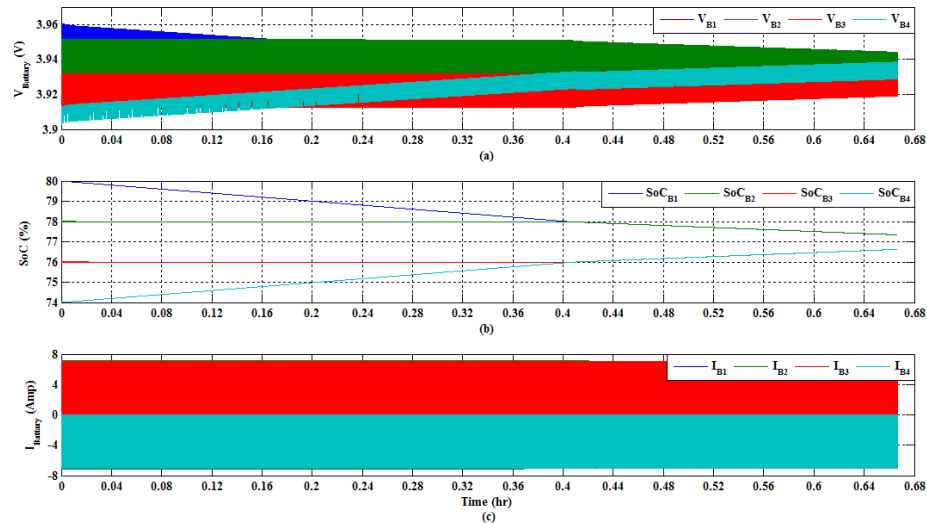

Fig. 23. Multi switched Inductor balancing a) cells voltage, b) cells SoC and c) cells and Inductor currents.

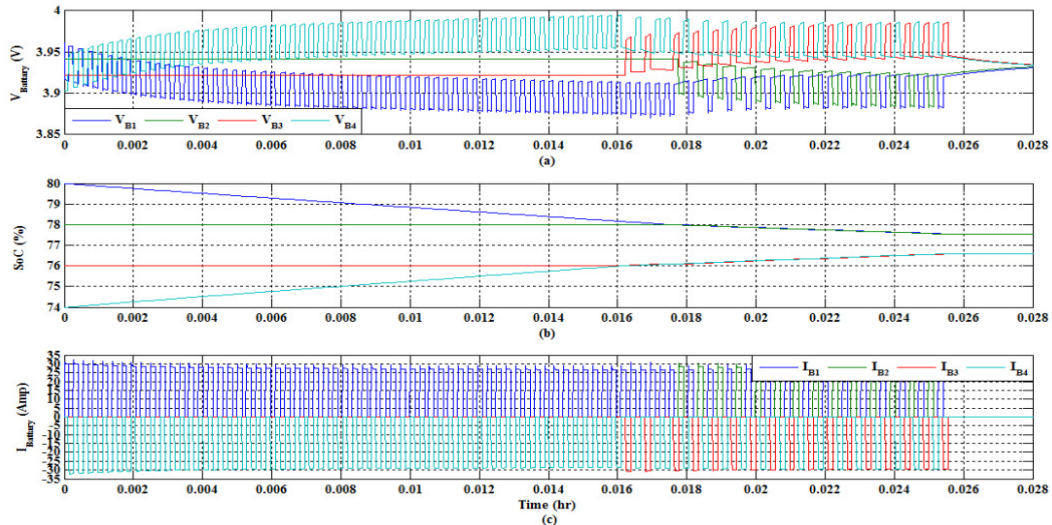

Fig. 24. Buck-Boost d.c converter balancing a) cells voltage, b) cells SoC and c) cells currents.

As shown in figures 18 to 24 the four cells balancing simulation results using different balancing topologies, they illustrate the cells' voltage, SoC and their currents.

In Fig. 18, the switched shunt resistor (SR) balancing topology shows also the resistors' currents. Here, the balancing occurred during charging, when a cell is nearly fully charged it will be shunted by the coupled switch and wait for the other cells to reach the fully charged state. In addition, the topology gives a fast equalization time only 36 min.

Figure 19 shows the switched capacitor (SC) balancing topology. It's clear that for a 6% SoC difference between the higher and lower cells the system took a very long time for complete balancing. In addition, the balancing current decreases due to the voltage difference decreasing between the cells, leading to a further increase of the balancing time, it took long equalization time about 5.25 hr and even more.

Figure 20 presents the double-tiered switched capacitor (DTSC) balancing topology, it also shows the capacitor 2 (between the cells 2 and 3) voltage. As the SC balancing the balancing currents decrease along the

balancing process. The DTSC balancing has balancing time smaller than the SC but it still relatively has a long balancing time 2.8 hr.

Fig. 21 illustrates the single switched capacitor (SSC) balancing topology, the same as the SC and the DTSC currents decreasing, with 3.25 hr equalize time.

The multi switched inductor (MSI) balancing is shown in Fig. 23, has fast equalization with time of 40 min. The single switched inductor (SSI) balancing topology shown in Fig. 22 has small balancing time 24 min. The MSI and SSI topologies have a constant and high equalization current that reduce the balancing time.

Figure 24 shows the buck-boost converter (BBC) balancing coupled with the EV auxiliary battery. This topology has the smallest equalization time (1.65 min.) depending the converter current used in discharging and charging the cells.

The following figures 25-31 illustrate the premonition simulated topologies from the energy and energy losses viewpoint. They will show the cells transferred and received energy with the same simulation condition mentioned before for the four cells.

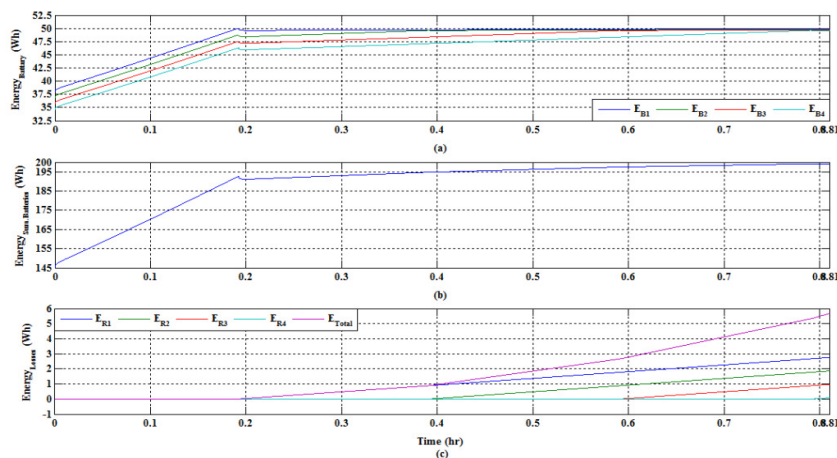

Fig. 25. Switched shunt resistor balancing a) cells energy, b) cells energy sum and c) the shunted resistors energy losses and summation.

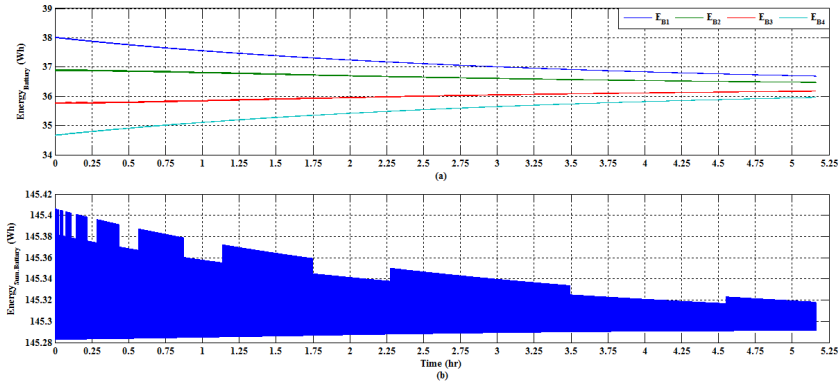

Fig. 26. Switched capacitor balancing a) cells energy, and b) cells energy sum.

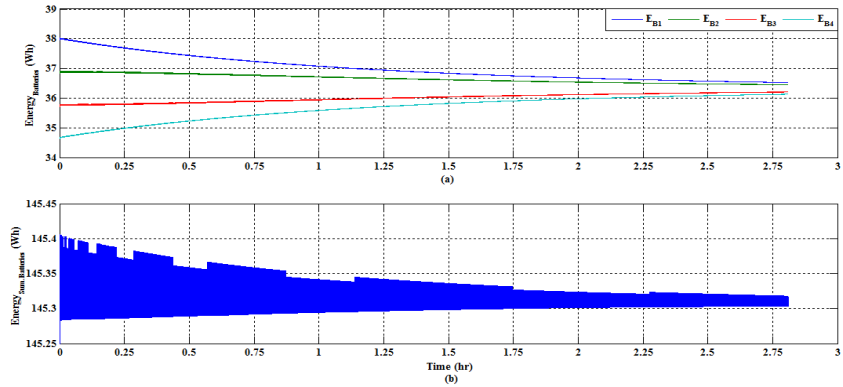

Fig. 27. Double-tiered switched capacitor balancing a) cells energy, and b) cells energy sum.

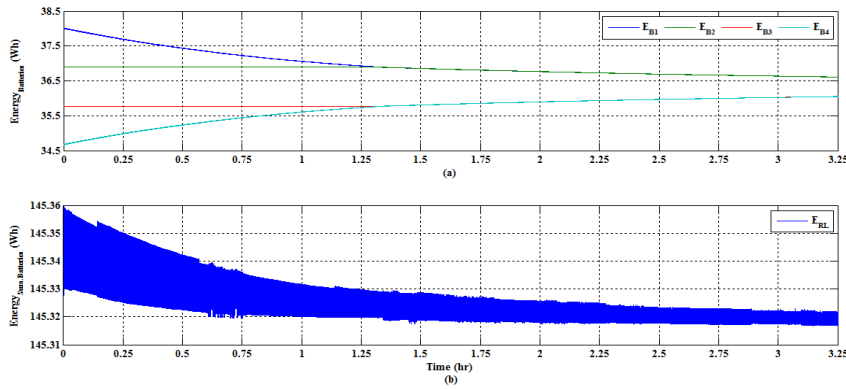

Fig. 28. Single switched capacitor balancing a) cells energy, and b) cells energy sum.

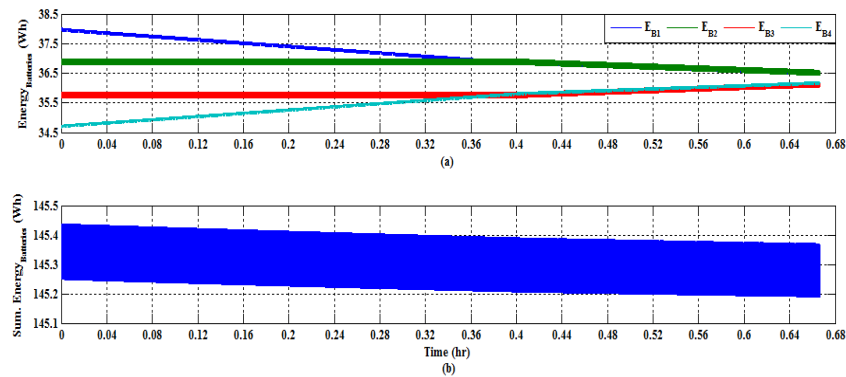

Fig. 29. Multi switched inductor balancing a) cells energy, and b) cells energy sum.

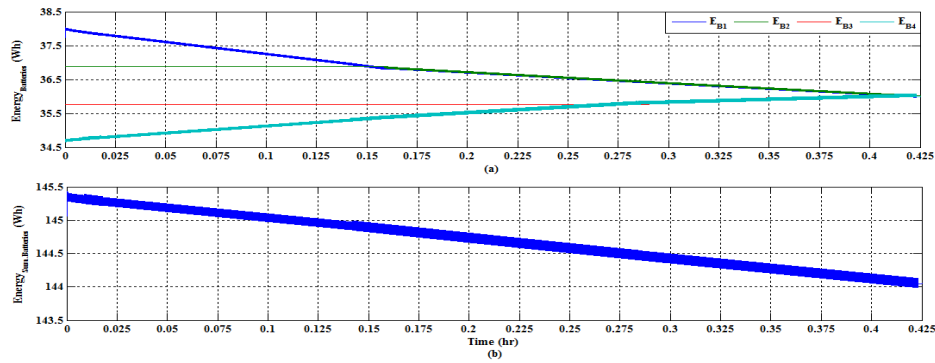

Fig. 30. Single switched inductor balancing a) cells energy, and b) cells energy sum.

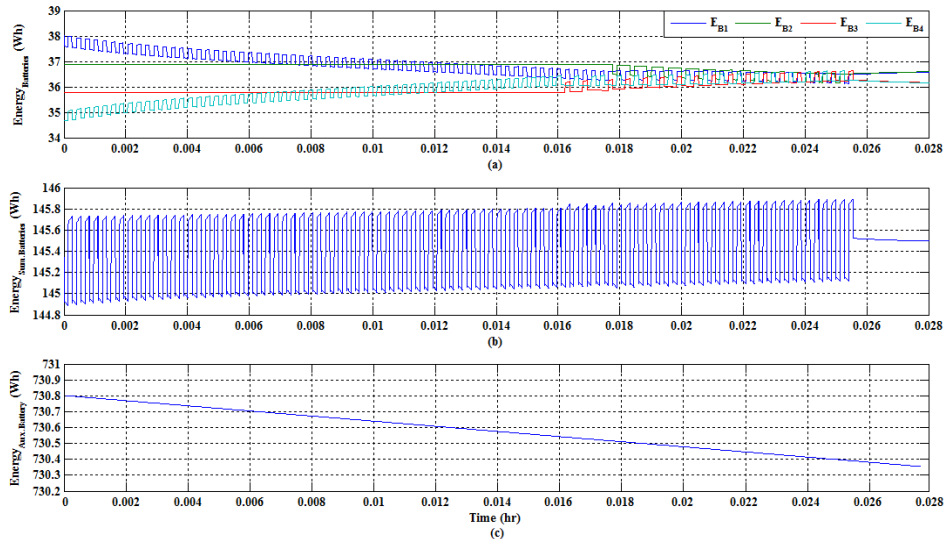

Fig. 31. Buck-boost d.c converter balancing a) cells energy, b) cells energy sum, and c) auxiliary battery energy.

Figures 25 to 31 show the cells' energy, the summation of cells' energy. The energy losses during the balancing process in Wh can be calculated from the cells energy sum at start (balancing process beginning) and at the end (cell balancing occurred).

Figure 25 shows the switched resistor balancing energy, as well as the energy losses in the resistors. The switched resistor (SR) method has a small equalization time with highest energy losses.

Figures 26, 27 and 28 show the cells' energy for the SC, DTSC and SSC respectively. Shuttling switched capacitor balancing topologies have minimum energy losses but with long equalization time.

Figures 29 and 30 illustrate the multi-switched inductor (MSI) and single switched inductor (SSI) balancing topologies with their accepted energy losses.

Figure 31 shows the buck-boost d.c converter (BBC) with energy transferring between the cells and the vehicle auxiliary battery balancing. Cells energy, cells energy sum and the auxiliary battery energy are illustrated. The BBC balancing gives the smallest energy losses and it has smallest equalization time.

Table 1 presents the simulation results comparison between the premonitions simulated balancing

topologies. It illustrates equalization time, cells energy sum at balancing start and end as well as the energy losses during the balancing process.

TABLE 1.
Simulation comparison of different cell balancing topologies.

Topology	Balance time (hr)	Sum. of cells energy (Wh)		
		Σ @ Start	Σ @ End	Σ Losses
SR	0.6 (36 min)	-	-	5.5
SC	5.25	145.35	145.29	0.06
DTSC	2.8	145.35	145.3	0.05
SSC	3.25	145.35	145.32	0.03
SSI	0.4 (24 min.)	145.35	144.1	1.25
MSI	0.67 (40 min)	145.35	145.25	0.1
BBC	.028 (1.7 min)	145.35 + 730.8	145.5 + 730.354	0.296
		Smallest	Highest	

BBC: Buck-boost converter between the cells and the auxiliary battery, **DTSC:** Double-tiered switched capacitor, **MSI:** Multi-switched inductor, **SC:** Switched capacitor, **SR:** Switched resistor, **SSC:** Single switched capacitor and **SSI:** Single switched inductor.

From the simulation results it is noted that:

1. The switched resistor (SR) method has a small equalization time with highest energy losses.
2. The Multi-winding transformer (MWT) shown in Fig. 9-a has a small equalization time but it is NOT suitable for Li-ion batteries because it depends on the voltage differences between cells and the Li-ion batteries features with a flat voltage with the operating range. More control is needed to be used with it.
3. The capacitor base methods have small energy losses but they have long equalization time.

4. The single switched capacitor (SSC) has smallest energy losses and its equalization time is acceptable compared with the switched capacitor (SC) balancing system.
5. Buck-boost d.c converter has the smallest equalization time with acceptable energy losses.

VII. Commercial evaluation

The premonition simulated balancing topologies' elements have been evaluated commercially. Tables 2 and 3 show the balancing topologies' elements number, rating, size and prices comparison.

TABLE 2
Balancing topologies elements number, rating and circuit size (main circuit, 4 cells)

Top.	R	m.Ω	A	L	μH	m.Ω	A	C	F	m.Ω	V	D	m.Ω	V	A	IC	SW	V	A	m.Ω	Size
SR	4	3900	2	-	-	-	-	-	-	-	-	-	-	-	-	-	4	8	4	9	+++
SC	3	10	2	-	-	-	-	3	.22	20	5.5	-	-	-	-	-	8	8	4	2	+
DTSC	4	10	2	-	-	-	-	4	.22	20	5.5	-	-	-	-	-	8	8	4	2	+
SSC	1	10	2	-	-	-	-	1	.22	20	5.5	-	-	-	-	-	9	8	4	2	++
MSI	3	1.5	8	3	100	25	8	-	-	-	-	-	-	-	-	-	6	8	16	2	+
SSI	1	1.5	8	1	100	25	8	-	-	-	-	8	-	5.5	8	-	8	8	16	2	++
BBC	2	3	8	1	120	50	11	1	.47	30	12	2	-	20	8	-	2+9	24	16	2	++
MWT	-	-	-	5	5.6	20	5.3	-	-	-	-	4	-	4.2	4	1	1	8	8	2	±

R: Resistor, L: Inductor, C: Capacitor, D: diode, SW: Switch, IC: Iron core.
+++ : Excellent, ++: Very good, +: Good, ±: Satisfactory and --: Poor.

TABLE 3
Balancing topologies elements number and prices (main circuit, 4 cells)

Top.	R	€/1	€	L	€/1	€	C	€/1	€	D	€/1	€	IC	€/1	€	SW	€/1	€	Total €
SR	4	.5	2	-	-	-	-	-	-	-	-	-	-	-	-	4	.6	2.4	4.4
SC	3	.5	1.5	-	-	-	3	6	18	-	-	-	-	-	-	8	.6	4.8	24.3
DTSC	4	.5	2	-	-	-	4	6	24	-	-	-	-	-	-	8	.6	4.8	30.8
SSC	1	.5	.5	-	-	-	1	6	6	-	-	-	-	-	-	9	.6	5.4	11.9
MSI	3	.7	2.1	3	7	21	-	-	-	-	-	-	-	-	-	6	1	6	29.1
SSI	1	.7	.7	1	7	7	-	-	-	8	.5	4	-	-	-	8	1	8	19.7
BBC	2	.7	1.4	1	3	3	1	8	8	2	.7	1.4	-	-	-	2+9	.8	8.8	22.6
MWT	-	-	-	5	.9	4.5	-	-	-	4	.5	2	1	5	5	1	1	1	12.5

R: Resistor, L: Inductor, C: Capacitor, D: diode, SW: Switch, IC: Iron core.

From Tables 2 and 3 it can be noted that;

1. The switched resistor balancing system has the smallest size and prices.
2. Multi-winding transformer balancing has the largest size.
3. double-tiered switched capacitor is the expensive balancing system.
4. Using the SSC, SSI or the buck-boost converter for balancing the have an acceptable system size.

A general comparison between all balancing topologies is given in Tables 4 and 5. Generally for low

power application the switched shunt resistor is good with its low cost, small size and very simple control. For simple, active control the switched capacitor is a good choice, it is suitable for HEV application but it takes a long equalization time. For faster equalization time switched inductor and transformer is suitable but it needs a complex control system and suffers magnetic losses. Energy converter topologies are superior for medium and high power application (HEV and PHEV) allowing full control of the balancing procedure unfortunately their cost and complexity is much higher.

TABLE 4
Comparison of different cell balancing topologies.

Topology	Equalization speed	Control Complexity	Implementation simplicity	Size	Cost	Charge discharge applications	Approx. Eff.	stress elements for n cells, m module								
								V	I	R	L	C	SW	D	IC	
FR	±	Very Simple	+++	+++	+++	Fixed	Low Power	-	0	0	n	0	0	0	0	0
SR	+	Simple	+++	+++	+++	Charge	Low Power	±	±	±	n	0	0	n	0	0
SC	±	Medium	++	+	+	Bidirectional	Medium/High	+++	++	++	0	0	n-1	2n	0	0
SSC	+	Complex	++	++	++	Bidirectional	Medium/High	+++	++	++	1	0	1	n+5	0	0
DTSC	+	Medium	++	+	+	Bidirectional	Medium/High	+++	++	++	0	0	n	2n	0	0
MSC	+	Complex	+	+	+	Bidirectional	Medium/High	+++	++	++	0	0	n-1	2n+2m	0	0
SSI	++	Complex	++	+	+	Bidirectional	Medium/High	++	++	+++	0	1	0	2n	2n-2	0
MSI	++	Complex	++	+	+	Bidirectional	Medium/High	++	++	+++	0	n-1	0	2n-2	0	0
SWT	+	Complex	+	+	±	Charge	Medium	+	+	+++	0	2	0	n+6	1	1
MWT	+	Medium	+	±	±	Charge	Medium	+	+	+++	0	n+1	0	2	0	1
MpT	+	Medium	++	±	±	Charge	Medium	+	±	±	0	2n	0	1	n	n
Ćuk	++	Complex	++	+	+	Bidirectional	Medium/High	++	++	++	0	2n-2	n-1	2n-2	0	0
BC	+++	Complex	+++	+	+	Bidirectional	Medium/High	+++	++	++	0	m	m	2m	0	0
BBC	+++	Complex	+++	+	+	Bidirectional	Medium/High	+++	++	++	0	1	1	n+7	0	0
FbC	+	Medium	+	±	±	Bidirectional	Medium	+	++	++	0	2n	0	2n	0	n
RC	+	Complex	±	±	±	Bidirectional	Medium	+	+	+	0	n/2	n	n	n	1
FBC	+++	Complex	++	±	±	Bidirectional	High	+++	±	±	0	0	m	4m	0	0
QRC	+	Complex	±	±	±	Bidirectional	Medium/High	++	-	-	0	2n-2	n-1	2n-2	0	0

FR: Fixed resistor, SR: Switched resistor, SC: switched capacitor, SSC: Single switched capacitor, DTSC: Double-tier switched capacitor, MSC: Modularized switched capacitor, SSI: Single switched inductor, MSI: Multi switched inductor, SWT: Single winding transformer, MWT: Multi winding transformer, MpT: Multiple winding transformer, BC: Buck converter, BBC: Buck-boost converter, FbC: Flyback converter, RC: Ramp converter, FBC: Full-bridge converter, QRC: Quasi-resonant Converter. +++: Excellent, ++: Very good, +: Good, ±: Satisfactory and -: Poor.

TABLE 5
Advantage and disadvantage of cell balancing topologies.

Scheme	Advantage	Disadvantage
1. Fixed Resistor	<ul style="list-style-type: none"> • Cheap. Simple to implement with a small size. 	<ul style="list-style-type: none"> • Not very effective. Thermal management requirements. • Inefficient due to its permanent energy losses.
2. Shunting Resistor	<ul style="list-style-type: none"> • Cheap, simple to implement and Fast equalization rate. • Charging and discharging but not preferable for discharging. • Suitable for HEV but for EV a 10mA/Ah resistor specified. 	<ul style="list-style-type: none"> • Not very effective; Relatively high energy losses • The requirement for large power dissipating resistors. • Thermal management requirements.
3. Switched Capacitor	<ul style="list-style-type: none"> • Simple control. Charging and discharging modes. • Low voltage stress, no need for closed loop control. 	<ul style="list-style-type: none"> • Low equalization rate. • High number of switches.
4. Single Switched Capacitor	<ul style="list-style-type: none"> • Simple control. Charging and discharging modes. • One capacitor with minimal switches. EV and HEV app. 	<ul style="list-style-type: none"> • Satisfactory equalization speed. • Intelligent control is necessary to fast the equalization.
5. Double Tiered Switched Capacitor	<ul style="list-style-type: none"> • Reduce balancing time to quarter than the switched capacitor. • Charging and discharging modes. EV and HEV applications. 	<ul style="list-style-type: none"> • Satisfactory equalization speed. • High number of switches.
6. Modularized Switched capacitor	<ul style="list-style-type: none"> • Low voltage and current stress. • Charging and discharging modes 	<ul style="list-style-type: none"> • Complex control is needed. • Satisfactory equalization speed.
7. single Inductor	<ul style="list-style-type: none"> • Fast equalization speed. • Good efficiency 	<ul style="list-style-type: none"> • Complex control is needed. Switches current stress. • Filtering capacitors are needed for high switching frequency.
8. Multi Inductor	<ul style="list-style-type: none"> • Fast equalization speed. • Good efficiency 	<ul style="list-style-type: none"> • Less complex control. Needs accurate voltage sensing. • Charging mode only. Switches current stress. • Filtering capacitors are needed for high switching current.
9. Single Windings Transformer	<ul style="list-style-type: none"> • Fast equalization speed. • Low magnetic losses. 	<ul style="list-style-type: none"> • High complexity control. Expensive implementation. • To add one or more cells the core must be changed.
10. Multi Windings Transformer	<ul style="list-style-type: none"> • Rapidly balancing. No closed-loop controls are required. • Suitable for both EV and HEV applications 	<ul style="list-style-type: none"> • High cost. Complex control. Complex magnetic. • The core will be changed if cell or more are added.
11. Multiple Transformers	<ul style="list-style-type: none"> • Fast equalization speed. Can be modularized • EV and HEV applications. New cells easily added. 	<ul style="list-style-type: none"> • High cost. Complex control. • Satisfactory efficiency due to magnetic losses.
12. Modularized Switched Transformer	<ul style="list-style-type: none"> • Fast equalization speed. Suitable for both EV and HEV. • Low voltage and current stress. 	<ul style="list-style-type: none"> • High cost. • Complex control.
13. Ćuk Converter	<ul style="list-style-type: none"> • Suitable for both EV and HEV applications. • Efficient equalization system. 	<ul style="list-style-type: none"> • Complex control. Accurate voltage sensing needed. • Satisfactory equalization speed.
14. Buck-Boost Converter	<ul style="list-style-type: none"> • Good equalization speed. • Easy for modular design. 	<ul style="list-style-type: none"> • High cost • Intelligent control needed.
15. Flyback Conv.	<ul style="list-style-type: none"> • EV and HEV application. Suitable for modularized system. 	<ul style="list-style-type: none"> • Voltage sensing needed. Satisfactory equalization speed.
16. Ramp Converter	<ul style="list-style-type: none"> • Soft switching along with a relatively simple transformer. 	<ul style="list-style-type: none"> • Complex control. Satisfactory equalization speed.
17. Full-Bridge Converter	<ul style="list-style-type: none"> • Fast equalization speed. • Ideal for transportation applications 	<ul style="list-style-type: none"> • High cost • Intelligent control needed.
18. Quasi-Resonant Converter	<ul style="list-style-type: none"> • Low switches current stress that increases its efficiency. 	<ul style="list-style-type: none"> • High cost • Complex and intelligent implementation needed.

VIII. Conclusion

Battery cell balancing is a key issue in electrically propelled vehicle battery management as it enhances the performance of the battery pack while increasing its cycle life and ensuring safe operation at all times. Several battery balancing topologies have been reviewed and simulated using MATLAB/Simulink. This comprehensive comparison of balancing solutions differing in cost, size, control complexity and implementation provides guidance to select the optimal solution for a given application.

References

- [1] Mohamed Daowd, Noshin Omar, Peter Van Den Bossche, and Joeri Van Mierlo, Passive and Active Battery Balancing comparison based on MATLAB Simulation, *7th IEEE Vehicle Power and Propulsion Conference, VPPC'11*, 2011.
- [2] Jian Cao, Nigel Schofield and Ali Emadi, Battery balancing methods: A comprehensive review, *IEEE Vehicle Power and Propulsion Conference, VPPC'08*. pp. 1-6, 2008.
- [3] K. Zhi-Guo, Z. Chun-Bo, L. Ren-Gui and C. Shu-Kang, "Comparison and Evaluation of Charge Equalization Technique for Series Connected Batteries, *37th IEEE Power Electronics Specialists Conference*, pp. 1-6, 2006.
- [4] S. Moore and P. Schneider, A Review of Cell Equalization Methods for Lithium Ion and Lithium Polymer Battery Systems, in *Proceedings of the SAE 2001 World Congress*, 2001.
- [5] M. J. Isaacson, R. P. Hollandsworth, P. J. Giampaoli, F. A. Linkowsky, A. Salim and V. L. Teofilo, Advanced lithium ion battery charger, *15th Annual Battery Conference on Applications and Advances*, pp. 193-198, Jan. 2000.
- [6] N. H. Kutkut, and D. M. Divan, Dynamic Equalization Techniques for Series Battery Stacks, *IEEE Telecommunications Energy Conference, INTELEC '96*, pp. 514-521, 1996.
- [7] B. Lindemark, Individual Cell voltage Equalizers (ICE) For Reliable Battery Performance, *IEEE 13th International Telecommunications Energy Conference, INTELEC '91*, pp. 196-201, 1991.
- [8] A. Thomas. Stuart, and Wei Zhu, Fast Equalization for Large Lithium Ion Batteries, *IEEE Aerospace and Electronic Systems Magazine*, Vol. 24, pp. 27-31, 2009.
- [9] Xiujuan Zhang, Peide Liu, and Darui Wang, The Design and Implementation of Smart Battery Management System Balance Technology, *Journal of Convergence Information Technology*, Vol. 6, No. 5, pp. 108-116, May 2011
- [10] Dorin V. Cadar, Dorin M. Petreus and Toma M. Patarau, An Energy Converter Method for Battery Cell Balancing, *IEEE 33rd International Spring Seminar on Electronics Technology (ISSE)*, pp. 290-293, 2010.
- [11] S. West, and P.T. Krein, Switched-Capacitor Systems For Battery Equalization, *IEEE Modern Techniques and Technology (MTT 2000). Proceedings of the VI International Scientific and Practical Conference of Students, Post-graduates and Young Scientists*, pp. 57-59, 2000.
- [12] C. Pascual, and P.T. Krein, Switched Capacitor System for Automatic Series Battery Equalization, *IEEE Applied Power Electronics Conference and Exposition, APEC '97 Conference Proceedings, 12th Vol. 2*, pp. 848-854, 1997.
- [13] Carmelo Speltino, Anna Stefanopoulou and Giovanni Fiengo, Cell Equalization in Battery Stacks Through State Of Charge Estimation Polling, *American Control Conference (ACC)*, pp. 5050-5055, 2010
- [14] A.C. Baughman, and M. Ferdowsi Double-Tiered Switched-Capacitor Battery Charge Equalization Technique, *IEEE Transactions on Industrial Electronics*, Vol. 55. pp. 2277-2285, 2008.
- [15] A. Baughman, and M. Ferdowsi, Double-Tiered Capacitive Shuttling Method for Balancing Series-Connected Batteries, *IEEE Conference on Vehicle Power and Propulsion*, pp. 109-113, 2005.
- [16] P. Hong-Sun, K. Chol-Ho, P. Ki-Bum, M. Gun-Woo and L. Joong-Hui, Design of a Charge Equalization Based on Battery Modularization, *IEEE Trans. on Vehicular Technology*, Vol. 58, pp. 3938-3946, 2009.
- [17] T. H. Phung, J. C. Crebier, A. Chureau, A. Collet And N. T. Van Nguyen, Optimized Structure for Next-to-Next Balancing of Series-Connected Lithium-ion Cells, *26th Annual IEEE Applied Power Electronics Conference and Exposition (APEC)*, pp. 1374-1381, 2011.
- [18] P. Sang-Hyun, K. Tae-Sung, P. Jin-Sik, M. Gun-Woo, and Y. Myung-Joong, A New Battery Equalizer Based on Buck-boost Topology *IEEE 7th International Conf. on Power Electronics*, pp. 962-965, 2007
- [19] C.S. Moo, Y.C. Hsieh, I.S. Tsai, and J.C. Cheng, Dynamic Charge Equalisation for Series-Connected Batteries, *IEEE Proceedings Electric Power Applications*, Vol. 150, No. 5, pp. 501-505, 2003.
- [20] Abusaleh M. Imtiaz, Faisal H. Khan and Hareesh Kamath, A Low-Cost Time Shared Cell Balancing Technique for Future Lithium-Ion Battery Storage System Featuring Regenerative Energy Distribution, *IEEE 26th Annual Applied Power Electronics Conference and Exposition (APEC)*, pp. 792-799, 2011.
- [21] Jong-Won Shin, Gab-Su Seo, Chang-Yoon Chun, and Bo-Hyung Cho, Selective Flyback Balancing Circuit with Improved Balancing Speed for Series Connected Lithium-ion Batteries, *the 2010 International Power Electronics Conference (IPEC)*, pp. 1180-1184, August 2010.
- [22] Markus Einhorn, Werner Roessler and Juergen Fleig, Improved Performance of Serially Connected Li-ion Batteries With Active Cell Balancing in Electric Vehicles, *IEEE Transactions on Vehicular Technologies*, Vol. xx, No. 99, pp. 1-10, May 2011.
- [23] Kyung-Hwa Parky, Chol-Ho Kim, Hee-Keun Cho, and Joong-Ki Seo, Design Considerations of a Lithium Ion Battery Management System (BMS) for the STSAT-3 Satellite, *Journal of Power Electronics*, Vol. 10, No. 2, pp. 210-217, March 2010.
- [24] Hong-Sun Park, Chong-Eun Kim, Chol-Ho Kim, Gun-Woo Moon and Joong-Hui Lee, A Modularized Charge Equalizer for an HEV Lithium-Ion Battery String, *IEEE Transactions on Industrial Electronics*, Vol. 56, No. 5, pp. 1464-1476, 2009.
- [25] Jingyu Yan, Zhu Cheng, Guoqing Xu, Huihuan Qian and Yangsheng Xu Fuzzy Control for Battery Equalization Based on State of Charge *IEEE 72nd Vehicular Technology Conference Fall*, pp. 1-7, 2010.
- [26] L. Yuang-Shung, D. Chun-Yi, C. Guo-Tian, and Y. Shen-Ching, Battery Equalization Using Bi-directional Ćuk Converters in DCVM Operation, *IEEE, 36th Power Electronics Specialists Conference, PESC '05*, pp. 765-771, 2005.
- [27] Wei Hong, Kong-Soon Ng, Jin-Hsin Hu and Chin-Sien Moo, Charge Equalization of Battery Power Modules in Series, *The 2010 International Power Electronics Conference*, pp. 1568-1572, 2010.
- [28] Chin-Sien Moo, Kong Soon Ng and Yao-Ching Hsieh, Parallel Operation of Battery Power Modules, *IEEE Transactions on Energy Conversion*, Vol. 23, No. 2, pp. 701-707, June 2008.
- [29] Chol-Ho Kim, Hong-Sun Park, Chong-Eun Kim, Gun-Woo Moon, and Joong-Hui Lee, Individual Charge Equalization Converter with Parallel Primary Winding of Transformer for Series Connected Lithium-Ion Battery Strings in an HEV, *Journal of Power Electronics*, Vol. 9, No. 3, pp. 472-480, May 2009.
- [30] S.Chakraborty, A.K. Jain, and N. Mohan, novel converter topology and algorithm for simultaneous charging and individual cell balancing of multiple Li-ion batteries, *26th Annual International Telecommunications Energy Conference*, pp. 248-253, 2004.
- [31] L. Yuang-Shung, T. Cheng-En, K. Yi-Pin and C. Ming-Wang, Charge Equalization Using Quasi-Resonant Converters in Battery String for Medical Power Operated Vehicle Application,

The International Power Electronics Conference (IPEC), pp. 2722-2728, 2010.

- [32] Yuang-Shung Lee, Guo-Tian Cheng, Quasi-Resonant Zero-Current-Switching Bidirectional Converter for Battery Equalization Applications, *IEEE Transactions on Power Electronics*, Vol. 21, No. 5, pp. 1213-1224, 2006.
- [33] L. Maharjan, S. Inoue, H. Akagi, and J. Asakura, State-of-Charge (SOC)-Balancing Control of a Battery Energy Storage System Based on a Cascade PWM Converter, *IEEE Transactions on Power Electronics*, Vol. 24, pp. 1628-1636, 2009.
- [34] T. Gotwald, Z. Ye and T. Stuart, Equalization of EV and HEV batteries with a ramp converter, *IEEE Transactions on Aerospace and Electronic Systems*, vol. 33, no. 1, pp. 307-312, Jan. 1997.
- [35] W. F. Bentley, Cell balancing considerations for lithium-ion battery systems, *12th Annual Battery Conference on Applications and Advances*, pp. 223-226, 1997.
- [36] Mohamed Daowd, Noshin Omar, Bavo Verbrugge, Peter Van Den Bossche, and Joeri Van Mierlo, Battery Models Parameter Estimation based on MATLAB/Simulink®, *EVS-25 Shenzhen, China*, Nov. 2010.
- [37] Mohamed Daowd, Noshin Omar, Peter Van Den Bossche, and Joeri Van Mierlo, Extended PNGV Battery Model for Electric and Hybrid Vehicles, *Journal of International Review of Electrical Engineering (IREE)*, Vol. 6, N.3, May-June 2011, pp. 1264-1278.

Authors

Mohamed Daowd¹, Noshin Omar^{1,2}, Peter Van Den Bossche², Joeri Van Mierlo¹.

¹ *Vrije Universiteit Brussel, Pleinlaan 2, 1050 Elsene, Belgium. Department of Electrical Engineering and Energy Technology (ETEC),*

² *Erasmus University College Brussels, IWT Nijverheidskaai 170, 1070 Anderlecht, Belgium*



Mohamed DAOWD

Born in Giza-Egypt. BSc, MSc graduation "Electrical Machines and Power Engineering" from Helwan University Cairo-Egypt in 1999 and 2006 respectively. Currently PhD Researcher, department of Electrical Engineering and Energy Technology (EETEC),

Vrije Universiteit Brussel, Belgium. Research interests include batteries in EVs specially BMS.

Pleinlaan 2, 1050 Brussel, Belgium. VUB, Building Z, ETEC.

Tel: +3226293396 Fax: +3226293620. Email: mdaowd@vub.ac.be

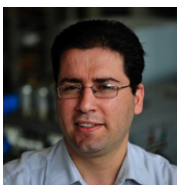

Noshin Omar

Was born in Kurdistan, in 1982. He obtained the M.S. degree in Electronics and Mechanics from Hogeschool Erasmus in Brussels. He is currently pursuing the PHD degree in the department of Electrical Engineering and Energy Technology ETEC, at the Vrije Universiteit Brussel, Belgium.

His research interests include applications of supercapacitors and batteries in HEVs.



Dr. Peter Van den Bossche

He graduated as civil mechanical-electrotechnical engineer from the Vrije Universiteit Brussel and defended his PhD at the same institution with the thesis "The Electric Vehicle: raising the standards". He is currently lecturer at the engineering faculties of

the Erasmushogeschool Brussel and the Vrije Universiteit Brussel, and in charge of co-ordinating research and demonstration projects for electric vehicles in collaboration with the international associations CITELEC and AVERE. His main research interest is electric vehicle standardization, in which quality he is involved in international standards committees such as IEC TC69, of which he is Secretary, and ISO TC22 SC21.



Prof. Dr. Ir. Joeri Van Mierlo

Obtained his Ph.D. in electromechanical Engineering Sciences from the Vrije Universiteit Brussel in 2000. He is now a full-time professor at this university, where he leads

the MOBI - Mobility and automotive technology research group. Currently he is in charge of the research related to the development of hybrid propulsion systems (power converters, supercapacitors, energy management, etc.) as well as to the environmental comparison of vehicles with different kind of drive trains and fuels (LCA, WTW). He is the author of more than 100 scientific publications. He is Editor in Chief of the World electric Vehicle Journal and co-editor of the Journal of Asian Electric Vehicles. Prof. Van Mierlo chairs the EPE "Hybrid and electric vehicles" chapter (European Power Electronics and Drive Association, www.epe-association.org). He is board member of AVERE and its Belgian section ABSE (European Association for Battery, Hybrid and Fuel Cell Electric Vehicles, www.aver.org). He is an active member of EARPA (association of automotive R&D organizations). Furthermore he is member of Flanders Drive and of Flemish Cooperative on hydrogen and Fuels Cells (VSWB). Finally Prof. Van Mierlo was Chairman of the International Program Committee of the International Electric, hybrid and fuel cell symposium (EVS24).