

Audio Übertrager

- Professionelle Audio Übertrager für verschiedene Anwendungen wie z.B. Mikrofon oder Line Inputs
- Sehr niedrige Distorsion, exzellente Frequenzkurve
- Kostengünstige Kabelversion für freies Anschliessen
- Voll Permalloy geschirmte Studio Version

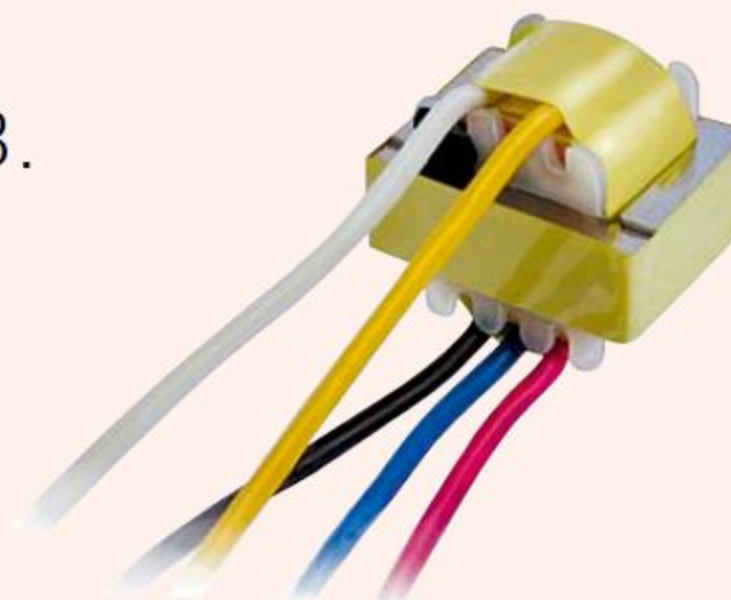

NTE10-3



NTL1

Liste Audio Übertrager

Artikelnr.	Windungszahl- verhältnis (prim : sec)	Impedanz- verhältnis	Eingangs- / Ausgangs- impedanz in Ω	Max. Eingangs- pegel* @ 50 Hz, 1% THD [dBu]	Anwendungen
NTE1	1 : 1	200 : 200	200 / 2k, (600 / 10k)	-3	Generell, Signalverteilung, elektr. Trennung
NTE4	1 : 4	200 : 3.2k	200 / 10 K	-7	Mikrofon Eingang Pegelanpassung
NTE10/3	1 : 3	200 : 1.8k	200 / 10 K	-7	Allg. Mikrofon Eingang Pegelanpassung
	1 : 10	200 : 20k	200 / 50 K	-6	
NTL1	1 : 1	10k : 10k	600 / 10k	+19	Line Eingang
NTM1	1 : 1	200 : 200	200 / 2k	+7	Mikrofon Eingang, Signalverteilung
NTM4	1 : 4	200 : 3.2k	200 / 10k	+9	Mikrofon Eingang, Pegelanpassung

* gemessen mit typischen Source / Load Impedanzen

Anschluss: NTE*... freie Kabel, NTL / NTM*... Printmontage, geschirmt; Mehr Infos auf www.neutrik.com

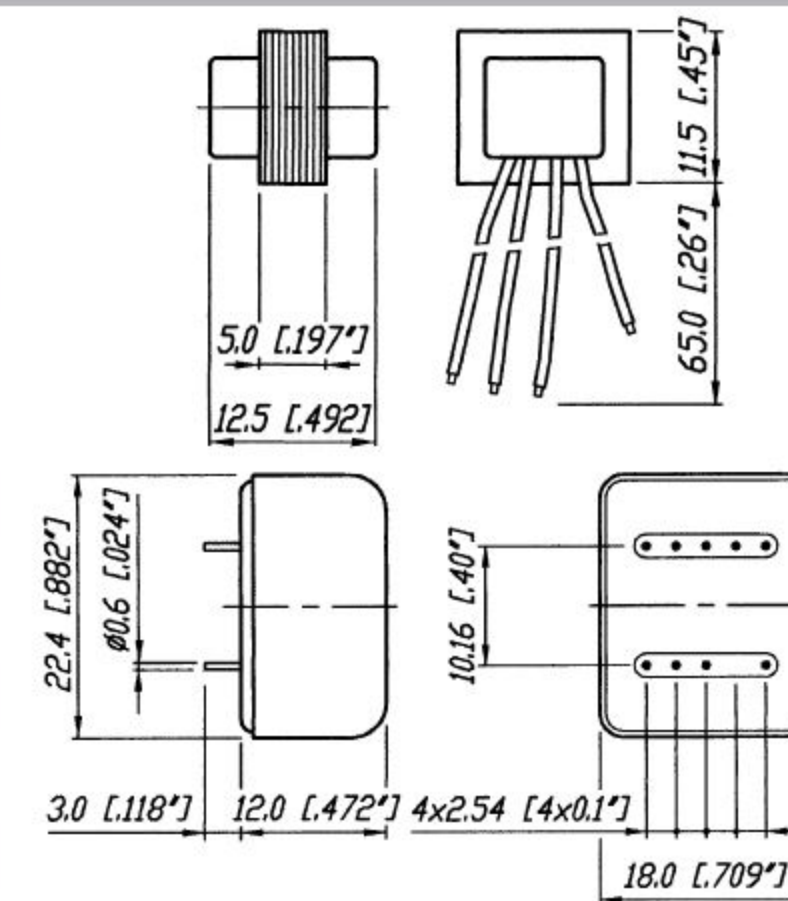

Audio Transformer

- Professional audio transformers for multiple applications, as e.g. microphone or line inputs
- Very low distortion, excellent frequency response
- Cost effective cable version for free wiring
- Fully permalloy-shielded studio versions

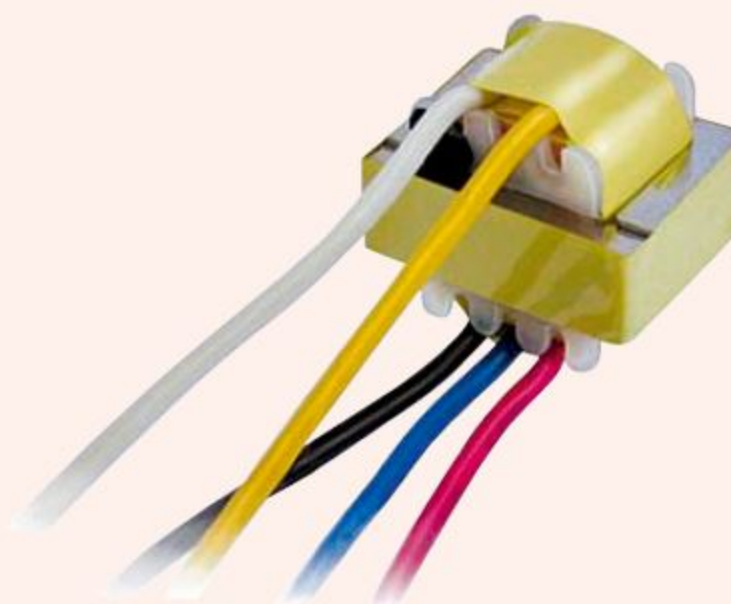

NTE10-3

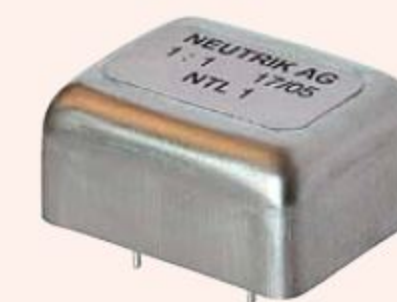

NTL1

Audio Transformer selection Guide

Part No.	Turns Ratio (prim : sec)	Impedance ratio	Source / load impedance in Ω	Max. Input level* @ 50 Hz, 1% THD [dBu]	Applications
NTE1	1 : 1	200 : 200	200 / 2k, (600 / 10k)	-3	General purpose, splitting, XLR inline
NTE4	1 : 4	200 : 3.2k	200 / 10 K	-7	Mic input step-up
NTE10/3	1 : 3	200 : 1.8k	200 / 10 K	-7	General purpose mic input step-up
	1 : 10	200 : 20k	200 / 50 K	-6	
NTL1	1 : 1	10k : 10k	600 / 10k	+19	Line input
NTM1	1 : 1	200 : 200	200 / 2k	+7	Mic input, splitting
NTM4	1 : 4	200 : 3.2k	200 / 10k	+9	Mic input step-up

* : measured with typical source / load impedances

Wiring: NTE*: free wires, NTL / NTM*... PCB mount, shielded; Find detailed specifications on www.neutrik.com

