

SC1224™

RGB COLOR MONITOR

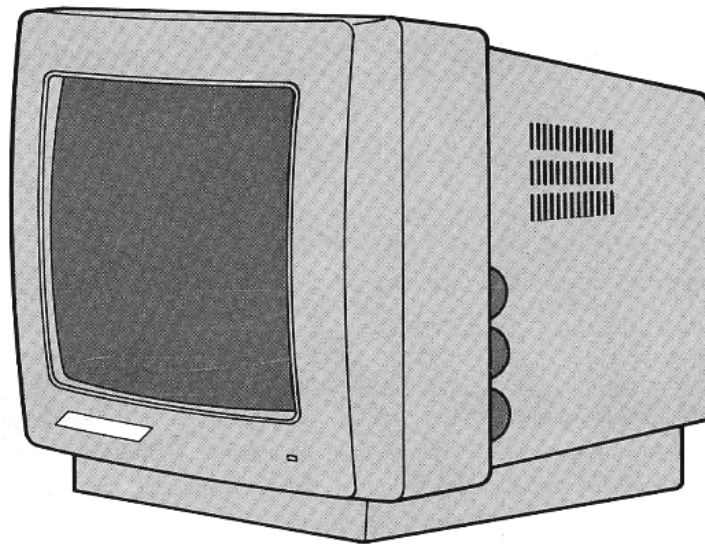

CONTENTS

SAFETY PRECAUTIONS	2
GENERAL INFORMATION	3
SPECIFICATIONS	3
CONTROL OPERATION	4
THEORY OF OPERATION	5
ADJUSTMENT AND MAINTENANCE	6-8
BLOCK DIAGRAM	9
TIMING CHART	10
TROUBLE SHOOTING CHART	11-20
CHASSIS IMPORTANT PARTS	21
COMPONENT OF P.C.B	22-24
EXPLODED VIEW DIAGRAM	25-26
SCHEMATIC DIAGRAM	27-28
REPLACEMENT PARTS LIST	29-33

SERVICE MANUAL

EXPLODED VIEW

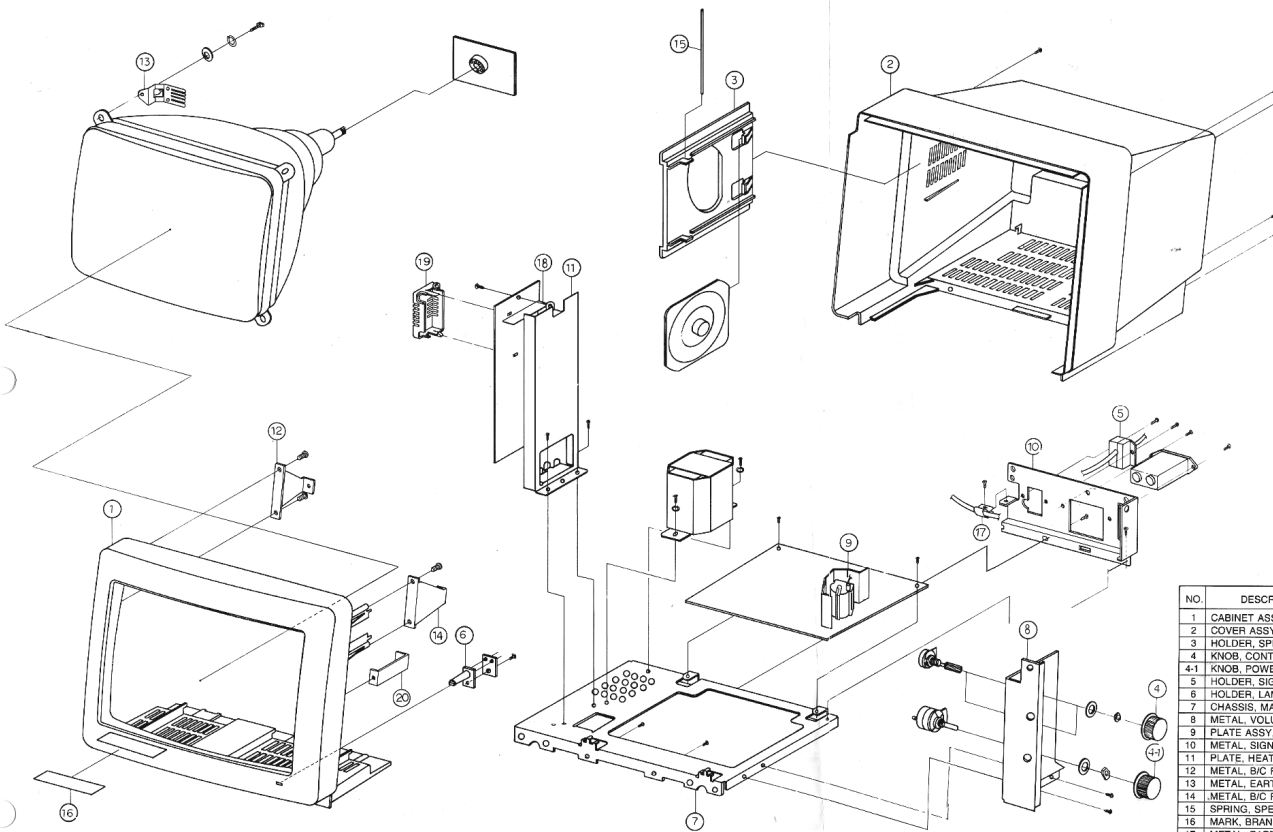

MECHANICAL PARTS

NO.	DESCRIPTION	PART NO.	MATERIAL	QTY	REMARK
1	CABINET ASSY	300-105D	HAN NAM HIPS 425TV	1	
2	COVER ASSY. BACK	303-814D	HAN NAM HIPS 425TV	1	
3	HOLDER, SPEAKER	341-236D	HAN NAM HIPS 425TV	1	
4	KNOB, CONTROL	440-488D	LUCKY ABS AF-303	2	
4-1	KNOB, POWER	440-207A	LUCKY ABS AF-303	1	
5	HOLDER, SIGNAL CORD	341-068A	LUCKY ABS AF-303	1	
6	HOLDER, LAMP	341-236A	LUCKY ABS AF-303	1	
7	CHASSIS, MAIN	311-485A		1	
8	METAL, VOLUME FIXING	430-273A		1	
9	PLATE ASSY. HEAT SINK	407-385A		1	
10	METAL, SIGNAL POWER	430-268C		1	
11	PLATE, HEAT SINK	407-384B		1	
12	METAL, B/C FIX (R)	430-420A		1	
13	METAL, EARTY	430-552A		1	
14	METAL, B/C FIX (L)	430-421A		1	
15	SPRING, SPEAKER	320-012B		1	
16	MARK, BRAND	410-193A		1	
17	METAL, EARTH HOLDER	430-554A		1	
18	PLATE, INSULATION	407-448A	SUMILITED	1	
19	COVER, FUSE	303-791A	LUCKY ABS AF-303	1	
20	METAL, VOLUME SUPPORTER	430-553A		1	

SCHEMATIC DIAGRAM

NOTES:

1. Resistors are shown in ohms
K = 1,000, M = 1,000,000
2. Capacitors are shown in μF
otherwise noted P = μpF
3. All resistors are $\pm 5\%$ tolerance
Unless otherwise indicated.

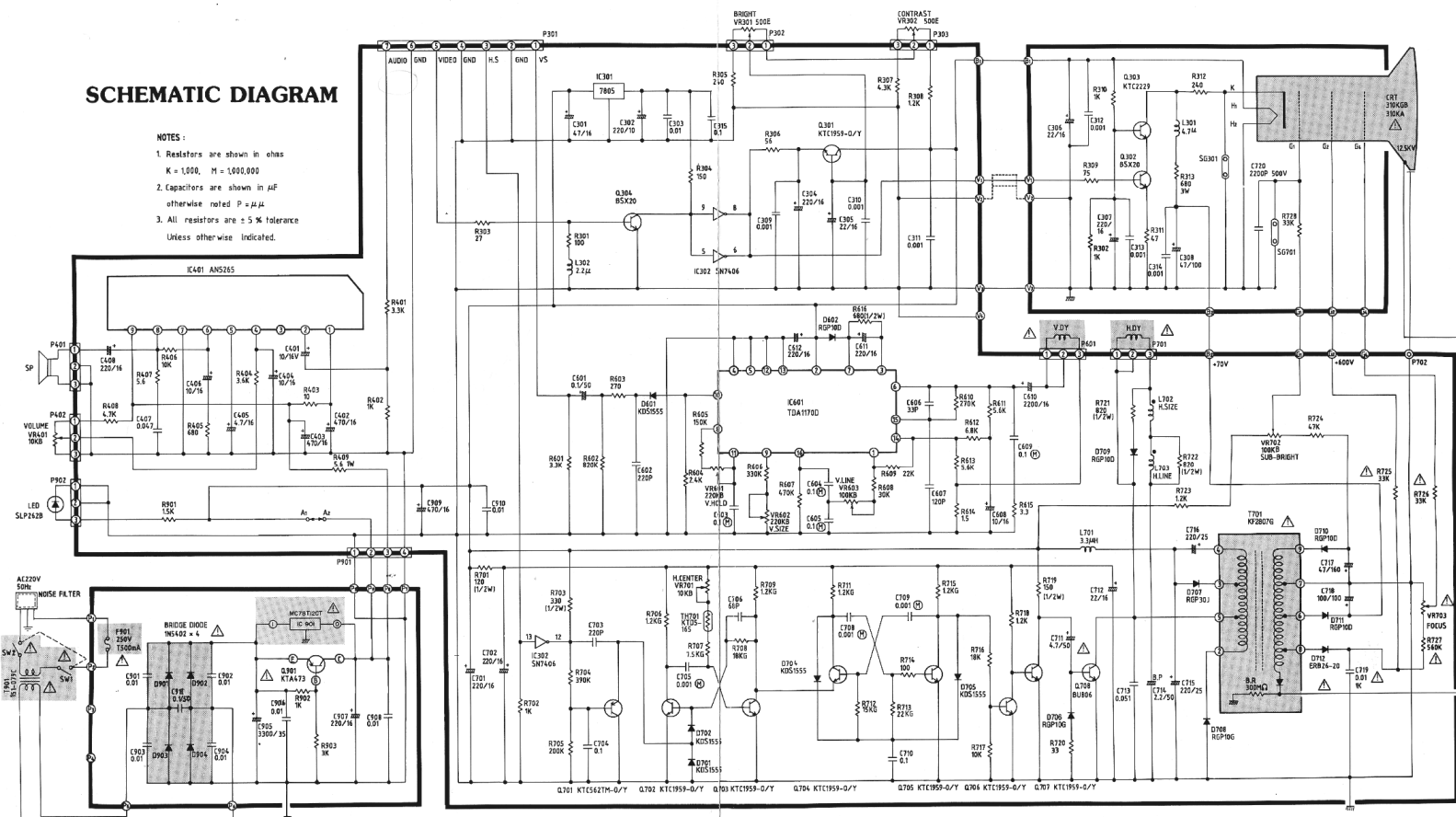

△ REPLACE ALL COMPONENTS MARKED WITH SAFETY SYMBOL WITH IDENTICAL TYPE

IMPORTANT SAFETY NOTICE

THE SHADED AREA ON THIS SCHEMATIC DIAGRAM INCORPORATES SPECIAL FEATURES IMPORTANT FOR PROTECTION FROM X-RADIATION, FIRE AND ELECTRICAL SHOCK HAZARDS, WHEN SERVICING IT IS ESSENTIAL THAT ONLY MANUFACTURER'S SPECIFIED PARTS BE USED FOR THE CRITICAL COMPONENTS IN THE SHADED AREAS OF THE SCHEMATIC.

IMPORTANT AVIS SUR LA SÉCURITÉ

LA PARTIE OMBRÉE DE CE DIAGRAMÉ SCHEMATIQUE COMPREND D'IMPORTANTES CARACTÉRISTIQUES SPÉCIALES CONÇUES POUR PROTÉGER DES RAYONS X ET DES DANGERS D'INCENDIE ET DE SECOURS ÉLECTRIQUES EN CAS DE BESOIN SI DES PIÈCES DE CETTE PARTIE OMBRÉE DOIVENT ÊTRE REMPLACÉES N'UTILISEZ QUE DES PIÈCES SPÉCIFIÉES PAR LE MANUFACTURIER.

P/N 484-476A

PINCUSHION AND BARRELLING

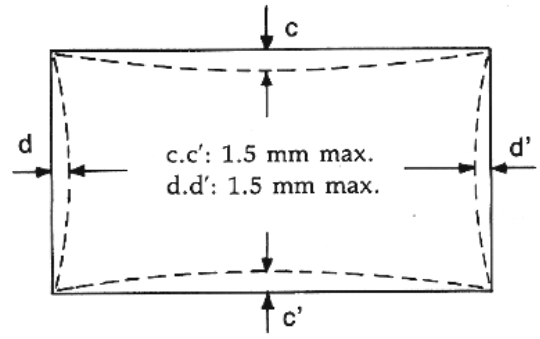
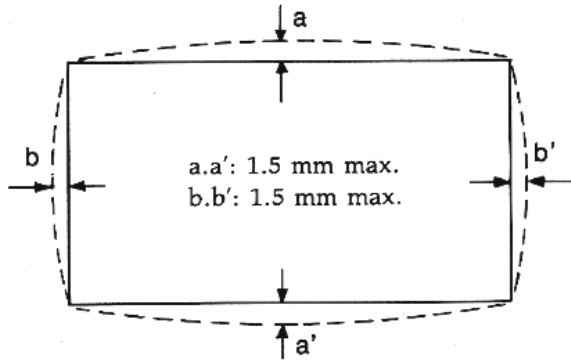

TRAPEZOID

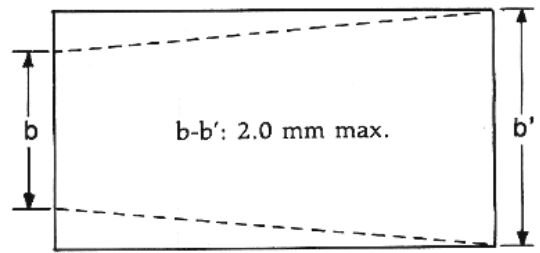
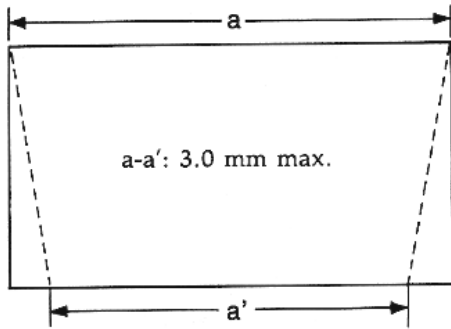

PARALLELOGRAM

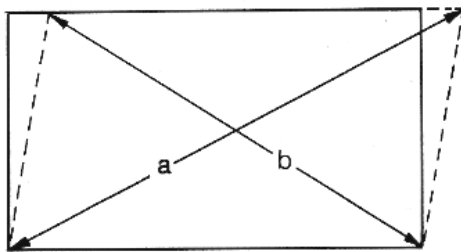

$a-b: 2.0 \text{ mm max.}$

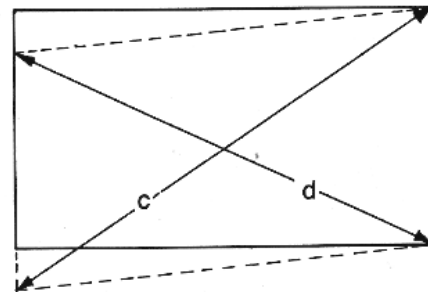

$c-d: 2.0 \text{ mm max.}$

YORK TILT

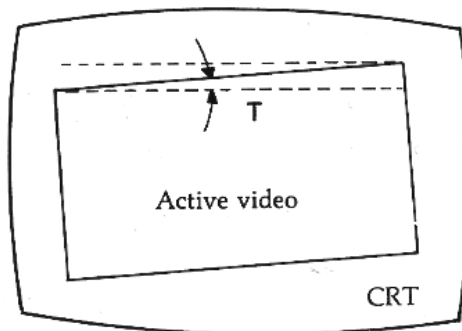

$T = 1^\circ \text{ max.}$

Fig. 2, Geometry Measurements

SPECIFICATIONS

1. CATHODE RAY TUBE

Type: Non-glare DARK
Size & Deflection angle: 12", 90°
Neck diameter: 20 mm
Phosphor: Paper White

2. INPUT

Input signal: TTL Signal

- Video : 1 V_{p-p} Positive
- Audio : 1 V_{p-p}
- Vertical Drive : 5 ± 1.5 V_{p-p} Negative
- Horizontal Drive : 5 ± 1.5 V_{p-p} Negative

Power Input : AC 220V 50Hz, 0.26A
Input Connector : 13 Pin Din Connector

3. SCANNING

Horizontal frequency : 35.7 KHz
Horizontal retrace time : 6.3 uS
Vertical frequency: 71.2 Hz
Vertical retrace time : 420 uS

4. VIDEO

- Display Area (HXV) : 210 mm × 130 mm
- Amplifier Type : Linear
- Frequency band width : 32 MHz
- Horizontal resolution : 1100 lines at center
- Display character : 80 × 50 characters

5. GEOMETRIC DISTORTION: 2.5% max.

6. LINEARITY

- Horizontal : 10% max.
- Vertical : 10% max.

7. EXTERNAL CONTROLS: BRIGHTNESS, CONTRAST, ON/VOLUME

ADJUSTMENT AND MAINTENANCE

CIRCUIT PROTECTION

Circuit protection is provided by one Mini fuse, on the power pc board. A 0.5 Ampere fuse (F901) is wired into one side of the AC line and provides primary protection to the entire chassis.

1. CENTERING ADJUSTMENT

CAUTION: The following adjustment points are close to the high voltage yoke terminal. If the raster is not centered in the raster opening, it may be centered by removing the cabinet back and adjusting the centering tabs on the neck of the tube, located at the rear of the deflection yoke. Turn the whole device clockwise or counter-clockwise. To increase the amount of raster shift, move the two tabs which project from the device, farther apart. If the raster is tilted on an angle, it may be straightened by loosening the deflection yoke locking clamp and rotating the deflection yoke.

2. FOCUS

Adjust the focus control (VR703) for best overall focus of the test pattern (marked with the symbol "%"). Usually the center and corners of the screen do not focus at the same setting and a compromise must be made.

3. BRIGHTNESS

Adjust subbrightness control (VR301) for visual cut off of the raster when external brightness is turned to maximum.

4. VERTICAL SIZE AND LINEARITY ADJUSTMENT

The vertical size control (VR602) should be adjusted for the picture to fill the screen vertically, the linearity control (VR603) should be adjusted for best overall vertical linearity. Adjustment of either control will not affect the adjustment of the other.

5. HORIZONTAL SIZE AND LINEARITY ADJUSTMENT

The horizontal size control (L702) is located on the main PCB, it should be adjusted for the picture to fill the screen horizontally, the linearity control (L703) should be adjusted for the best overall horizontal linearity adjustment so neither control will affect the adjustment of the other.

SAFETY PRECAUTIONS

DANGER

There are special components used in ATARI color monitor which are important for safety. These parts are shaded on the schematic diagram and on the replacement parts list. It is essential that these critical parts should be replaced with the manufacturer's specified parts to prevent X-RADIATION, shock, fire or other hazards. Do not modify the original design without obtaining written permission from ATARI or this will void the original parts and labor guarantee.

X-RADIATION

The only potential source of X-Radiation is the picture tube. However, when the high voltage circuitry is operating properly there is no possibility of an X-Radiation problem. The basic precaution which must be exercised is to keep the high voltage at the factory-recommended level: the nominal high voltage is 23.0KV and must not exceed 24.0KV at zero beam current at rated voltage. The following steps describe how to measure the high voltage and how to prevent X-radiation.

Note: It is important to use an accurate high voltage meter calibrated periodically.

- To measure the high voltage, use a high impedance high voltage meter. Connect (-) to chassis and (+) to the CRT anode button.
- Turn the brightness control fully counterclockwise.
- Measure the high Voltage. The high voltage meter should indicate at the factory-recommended level.
- If the upper meter indication exceeds the maximum level, immediate service is required to prevent the possibility of premature component failure.
- To prevent X-Radiation possibility, it is essential to use the specified picture tube.

CAUTION: No modification of any circuit should be attempted. Service work should be performed only after you are thoroughly familiar with all of the following safety checks and servicing guidelines.

SAFETY CHECK

Care should be taken while servicing this color monitor because of the high voltage used in the deflection circuits. These voltages are exposed in such areas as the associated flyback and yoke circuits.

FIRE & SHOCK HAZARD

- An isolation transformer must be inserted between the color monitor and AC power line before servicing the chassis.
- In servicing, attention must be paid to the original lead dress especially in the high voltage circuit. If a short circuit is found, replace all parts which have been overheated as a result of the short circuit.
- All the protective devices must be reinstalled per original design.
- Soldering must be inspected for the cold solder joints, frayed leads, damaged insulation, solder splashes or the sharp points. Be sure to remove all foreign materials.

IMPLOSION PROTECTION

All used display tubes are equipped with an integral implosion protection system, but care should be taken to avoid damage and scratching during installation. Use only same type display tubes.

GENERAL INFORMATION

- The SC1224 color monitor has the following features:
 - Uses 3 different, independent lines to drive the display—a RED, a GREEN, and an BLUE line.
 - Has a bandwidth 18 MHz typical and medium-resolution CDT (Color Display Tube). So it has a great resolution and can display 80-column lines without blurring the characters.
 - Uses the positive-level. Analog-compatibility at a frequency of 15.75 KHz.
- Displays 2000 characters using 8 X 8 dots format.
- Has its own power control and indicator using the SMPS (Switching Mode Power Supply). The SMPS in your color monitor automatically switches to match the applied power (AC 220V).
- Is compatible with ATARI ST Personal Computers.

SPECIFICATIONS

1. PICTURE TUBE

SIZE	: 12 inch
GUN	: In-line
DEFLECTION ANGLE	: 90°
NECK DIAMETER	: 29.1 mm
PHOSPHOR	: R.G.B

2. SIGNAL

INPUT SIGNAL	: R.G.B Analog Negative
H/V SYNC.	: TTL LEVEL
SIGNAL CONNECTOR	: 13 PIN "D" type
DISPLAY COLOR	: All colors

3. POWER

	: AC 220V 50Hz 0.4A
--	---------------------

4. SCAN FREQUENCY

	: 15.75KHz (H), 60Hz (V)
--	--------------------------

5. DISPLAY CHARACTERS

	: 25 rows X 80 columns
--	------------------------

6. CONTROLS

FRONT	: On/Volume, Contrast, Brightness (See Fig. 1)
REAR	: V-Lin., V-Size, V-Hold, H-Position, H-Hold (See Fig. 1)

7. ENVIRONMENT

OPERATING TEMPERATURE	: 10-40°C Ambient
-----------------------	-------------------

8. TUBE

	: 1
--	-----

9. IC

	: 4
--	-----

10. TRANSISTOR

	: 30
--	------

11. DIMENSIONS

WIDTH	: 327 mm [12.87 inch]
DEPTH	: 367 mm [14.45 inch]
HEIGHT	: 290 mm [11.42 inch]

12. WEIGHT (SET)

	: 10.7 Kg [23.54 lbs]
--	-----------------------

CONTROL OPERATION

FRONT and SIDE VIEW

REAR VIEW

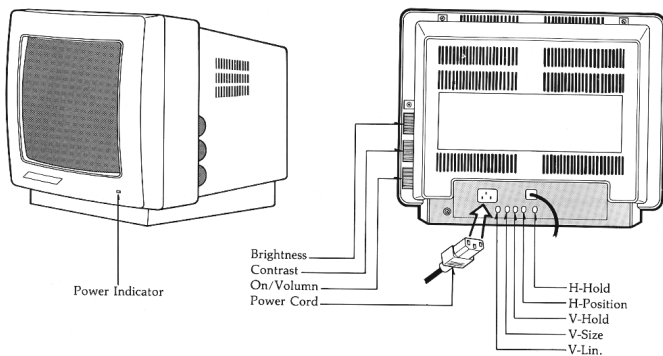

[Figure 1] Monitor Controls

ON/VOLUME

Turn on the monitor by turning this knob clockwise. The Power Indicator on the front of the monitor shows that the power is ON or OFF. Always turn on the monitor before turning on the computer. To turn the power off, just turn this knob counterclockwise. This knob also controls the volume level. Your monitor is equipped with a small speaker located on the left side panel. As you turn the knob further clockwise, the volume level increases; as you turn it counterclockwise, the volume level decreases. Your computer is capable of sending audio signals to the monitor, and many programs and games will make use of the speaker.

CONTRAST

Turn this knob clockwise to increase contrast.

BRIGHTNESS

Turn this knob clockwise to increase brightness.

V-LIN. (R635)

Turn this Potentiometer to conform the picture size vertically, i.e. this knob adjusts the vertical linearity.

V-SIZE (R616)

Turn this Potentiometer to adjust the vertical size of the picture.

V-HOLD (R603)

Turn this Potentiometer to stop vertical rolling of the picture.

H-POSITION (R710)

Turn this Potentiometer to the right to move the center of the picture to the right. Turn it counterclockwise to move the center of the picture to the left.

H-HOLD (R716)

Turn this Potentiometer to stop horizontal rolling of the picture.

POWER SOCKET

Plug this socket into a power outlet before turning on the power switch.

THEORY OF OPERATION

POWER SUPPLY

The power supply is a SMPS (switching mode power supply) that consists of switching IC950 (STR41090), SMPS transformer (T950), and the associated components. The basic theory of the SMPS is the circuit of self oscillation. The primary winding of the SMPS transformer is applied the pulse by operating Q931. Therefore, rectified DC 115V and DC 12V, 14V is obtained by D960, D961, D962 in the secondary winding of SMPS transformer T950.

START UP CIRCUIT

An initial start-up circuit drives the horizontal output stage when the set is initially turned on. This circuit consists of transistor Q701 and its associated components. It provides a drive pulse to the horizontal drive transistor Q702. Once the FBT-driven voltages operate, diode D706 is forward-biased and diode D701 is reverse-biased, providing DC 24V to IC601 and Q702. Switching the voltage supply circuit in the above manner, result in saving power consumption.

HORIZONTAL AND VERTICAL DEFLECTION SYNCHRONIZATION

The IC701 performs the horizontal synchronization (oscillator). A horizontal rate output pulse is coupled from IC701 pin 12 to the horizontal driver Q702. The driver stage drives the horizontal output Q703.

The horizontal sync signal coupling IC701 pin 1 is derived from dividing between R708 and R709. 13 of IC701. A pulse from the FBT pin 2 is rectified by D705.

HORIZONTAL AFC AND OSCILLATION LIMITER

The AFC circuit consists of phase detection circuit of IC701 and the associated component. The oscillation limit circuit is necessary to prevent the pulse from excessive high voltage. This circuit is located in IC701 and controls the oscillator to maintain the control signal in its correct frequency and in phase with the horizontal sync signal.

X-RAY PROTECTION CIRCUIT

The X-ray protection circuit consists of D704, R725 (hold down), R724, R726 and the associated component that connected to pin 13 of IC701. A pulse from the FBT pin 2 is rectified by D705. Under normal operating conditions, the resultant voltage maintains the specified value.

If a malfunction cause excessive high voltage, the amplitude of the pulse from the FBT increases, causing a corresponding increase in D704 which results in a voltage increase at pin 13 of IC601. A voltage increase at IC701 pin 13 makes the X-ray protection circuit conduct, and the horizontal oscillation operation no longer functional.

The circuit latches as above, and it's necessary for the circuit to turn the power off for at least 30 seconds to function again.

VERTICAL OSCILLATION/DRIVE CIRCUIT

The time constant circuit that determines the vertical oscillation frequency consists of IC701, C602, R603 and C603 connected at IC701 pin 18. Vertical size control function is performed by R615, causing the negative feed back to change.

VERTICAL OUTPUT

Vertical output circuit consists of IC601 and associated component.

HORIZONTAL DRIVE CIRCUIT

To obtain horizontal drive pulses from IC701 pin 12, the horizontal oscillator must be working. Horizontal drive pulses from IC701 pin 12 are applied to horizontal driver Q702. The B⁺ for Q702 is supplied from the 50V line through D706. During initial receiver turn-on before the FBT (drive supply voltages are developed), an initial B⁺ is supplied to Q702 from the regulated 115 volt line through R704.

HORIZONTAL OUTPUT

Horizontal drive pulses from Q702 are coupled through T701 to the base of horizontal output Q703. Transistor Q703 is biased on when the beam is at about mid-screen.

The charge stored on C732 and C733 causes current to flow through the horizontal yoke winding and Q703 to ground. When the beam reaches the right side of the screen, Q703 is turned off, and the current in the yoke is directed into C715 and C716. At the same time current flows into C715 and C716 from the regulated B⁺ via the FBT primary winding.

Due to resonance, the current then reverses and flows back through the horizontal yoke winding into C732 and C733. This action deflects the electron beam back to the +115V regulated B⁺.

PINCUSHION CORRECTION

The pincushion correction circuit consists of T703, Q602 and its associated components. The horizontal yoke current is increased or decreased in response to vertical parabola pulses.

POWER SUPPLY DESCRIPTIONS

This SMPS (switching mode power supply) using STR41090 obtains rectified DC115V, 12V, 14V from AC220V. Power is supplied in the following procedure:

- 1) AC220V supplied from the AC socket is rectified by BD901.
- 2) Rectified voltage is supplied to the T950. As to STR41090. Voltage which is primarily rectified by D951, is supplied to pin 2 of IC951 through R952, R953, R954.
- 3) At this moment, a pulse is generated at pin 3 of the IC950, which switches Q3 by internal oscillation of IC951.
- 4) This oscillation causes IC950 to switched, and at the secondary terminal of T950, a voltage proportional to the turn ratio is generated.
- 5) The generated voltage supplies DC 115V, 12V, 14V to the output terminal after the rectified by D960, D961, D962 and filtered by C961, C963, C965 and L961.
- 6) Between Pins 5 and 6 of T950, a voltage is generated proportional to turn the ratio from voltage generated between Pins 11 and 12.
- 7) Detecting voltage (pin 1 of IC950) is obtained through D950 by generated voltage (pin 6 in T950) is 90V.
- 8) Over current protection circuit (Q950, R951) is existed in order to protect Q3 in IC950 from surge current which may be caused at power switch on or off and output short-circuit.

ADJUSTMENT AND MAINTENANCE

GENERAL INFORMATION

All adjustments are thoroughly checked and corrected when the monitor leaves the factory. Therefore the monitor should operate normally and produce proper color and pictures upon installation. However, several minor adjustments may be required depending on the particular location in which the monitor is to operate. This monitor is shipped completely in cardboard carton. Carefully draw out the monitor from the carton and remove all packing materials. Plug the power cord into a convenient 220 volts 50 Hz AC power outlet. Never connect to direct current or any other power outlet or frequency. Check and adjust all the customer controls such as BRIGHTNESS, and CONTRAST to obtain a normal picture.

AUTOMATIC DEGAUSSING

A degaussing coil is mounted around the picture tube so that external degaussing is normally unnecessary after moving the monitor. The monitor should be properly degaussed upon installation. The degaussing coil operates for about 1 second after the power to the monitor is switched ON. If the set is moved or faced in a different direction, the power switch must be switched off for at least 10 minutes in order that the automatic degaussing circuit operates properly.

Should the chassis or parts of the cabinet become magnetized to cause poor color purity, use an external degaussing coil. Slowly move the degaussing coil around the faceplate of the picture tube, the sides and front of the monitor, and slowly withdraw the coil to a distance of about 2 meters before disconnecting it from the AC source. If color shading still persists, perform the CONVERGENCE ADJUSTMENT procedures, as mentioned later.

HIGH VOLTAGE CHECK

WARNING: There is no HIGH VOLTAGE ADJUSTMENT on this chassis. The +115 volt power supply must be properly adjusted to insure the correct high voltage.

1. Connect an accurate high voltage meter to the second anode of the display tube.
2. Turn on the monitor. Set the BRIGHTNESS and CONTRAST controls to minimum (zero beam current).
3. High voltage will be measured below 24.0 KV.
4. Rotate the BRIGHTNESS control to both extremes to be sure that the high voltage does not exceed the limit of 24.5 KV under any conditions.

FS CIRCUIT CHECK (Hold Down)

The FS (fail safe) circuit check is indispensable for the final check. Checking should be done following steps:

1. Turn the power switch ON and adjust customer controls for normal operation.
2. Connect a VTVM between (the cathode of D704) and the chassis ground.
3. Adjust brightness, and contrast, for mechanical minimum.
4. Adjust the Hold-down VR (R725) on the main board for the voltage of (the cathode voltage of D704) in DC10.25V.
5. After adjusting the voltage, fix the hold down VR (R725) with EPOXY or same kind of bond.
6. Check the set in the hold down when the voltage of TP5 (the cathode voltage of D704) is 13.2V +0.5, -0V.
7. If this monitor is not the FS (fail safe), repeat steps 1 through 5.

HORIZONTAL OSCILLATOR ADJUSTMENT

If there is an indication of unstable horizontal sync., adjust the HORIZONTAL HOLD control (R716) until screen image is stable.

VERTICAL OSCILLATOR ADJUSTMENT

If the picture moves up or down on the screen, adjust the VERTICAL HOLD control (R603) at the back of the monitor until there is a single image without vertical movement.

VERTICAL SIZE ADJUSTMENT

The vertical size control (R616) on the main board changes the size of the picture or pattern, having an equal effect on the top and bottom. The final adjustment for the V-size of picture is 150 mm for 12".

FOCUS ADJUSTMENT

Adjust the FOCUS control on the focus pack for well defined scanning lines in the 1/4 and 3/4 points of the screen.

HORIZONTAL WIDTH ADJUSTMENT

Adjust the horizontal width control coil (L702) by turning it with a hexagonal adjusting tool so that the width of the picture (data display area) is 210 mm for 12".

H-POSITION ADJUSTMENT

Adjust the H-position control (R710), so that the center of picture is the same as the mechanical center of the screen.

V-LINEARITY ADJUSTMENT

1. Display the cross hatch with the character generator.
2. Adjust R635 (V-LIN.) to the best condition.
3. Non-Linearity should be within $\pm 7\%$.
4. If V-size is changed after adjusting R635 (V-LIN.), readjust R616 (V-SIZE). At the time, signal is reverse pattern.

SUB-BRIGHTNESS ADJUSTMENT

1. Supply white color with a computer to the video input terminal.
2. Turn the contrast to the maximum with the contrast volume (fully clockwise) and BRIGHTNESS to the minimum with the bright volume (fully counterclockwise).
3. Adjust the sub-bright volume (R742) to cut-off the picture slightly.

VERTICAL CENTER ADJUSTMENT

Adjust the V-center control (R626), so that the center of the picture is the same as the mechanical center of the screen.

SIDE PCC ADJUSTMENT

1. Display the reverse pattern with the character generator.
2. Adjust to minimum by rotating R621 (side PCC).
3. At this time, the pincushion or barrel distortion should be within 1.5% (max.)

WHITE BALANCE ADJUSTMENT

1. EQUIPMENT

- Video Signal generator: LVG-1600 (Analog input)
R: 1Vp-p G: 1Vp-p B: 1Vp-p
- Oscilloscope
- W/B meter
- Color analyzer

2. Adjustment 1

- Input the 16 step wave 4 Pattern to the set.
- Set the BRIGHTNESS, CONTRAST VOL to the maximum.
- Set the Video output level (R511 rear part) 45Vp-p with adjusting the G.DRIVE (R303).
- Set the Video output level (R510 rear part) 45Vp-p with adjusting the R.DRIVE (R323).

- Adjust R.LEVEL (R369) in order to agree with R and G. output level when CONTRAST is minimum position.
- Adjust the R.DRIVE again in order to agree with R and G. output level when CONTRAST is maximum.
- When CONTRAST is maximum or minimum, As above (4) (5) (6) adjust the B.DRIVE (R343) in order to agree with B and G. OUTPUT Level.

3. Adjustment 2

- Set the SCREEN, CONTROL BRIGHTNESS, CONTRAST VOL.
- Set the SUB BRIGHT (R742) to the maximum.
- Set the R.CUT OFF (R317), G. CUT OFF (R337) B. CUT OFF (R357) to the center position.
- Input the reverse pattern.
- Set the reverse pattern 3FL in the COLOR ANALYZER with rotating the SCREEN CONTROL.
- In the case, adjust R.G.B CUT OFF (R317, R337, R357) As below X.Y with W/B METER.
X: $0.28 \pm 0.002 = 0.279 - 0.283$
Y: $0.311 \pm 0.002 = 0.309 - 0.313$

4. Adjustment 3

- Set the CONTRAST AND BRIGHTNESS VOL to the maximum. Set the reverse pattern 28FL in the COLOR ANALYZER with rotating the SUB-BRIGHT (R742).

CONVERGENCE ADJUSTMENT

NOTE: Before attempting any convergence adjustments, the monitor should be operated for at least fifteen minutes.

• Center Convergence Adjustment

1. Supply a crosshatch pattern with a color character generator to the video input.
2. Adjust the brightness and contrast controls for a well defined pattern.

3. Adjust the two tabs of the 4-pole magnets to change the angle between them (See Figure 3) and superimpose red and blue vertical lines in the center area of the picture screen. (See Figure 4).

4. Turn both the tabs at the same keeping the angle constant to superimpose red and blue horizontal lines at the center of the screen. (See Figure 4)

5. Adjust the two tabs of the 6-pole magnets to superimpose red/blue line and a green one. Adjusting the angle affects the vertical lines, and rotating both magnets affects the horizontal lines.

6. Repeat adjustment steps 3,4,5 describing red, green and blue movements. The 4-pole magnets and the 6-pole magnets have mutual affection making dots movement complex.

• Circumference Convergence Adjustment

1. Loosen the clamping screw of deflection yoke to allow the yoke to tilt.

2. Put a wedge temporarily, as shown in Figure 2. (Do not remove the cover paper on the adhesive part of the wedge.)

3. Tilt front of the deflection yoke up or down to obtain better convergence in circumference. (See Figure 2) push the mounted wedge into the space between display tube and the yoke to fix the yoke temporarily).

4. Put the other wedge into the bottom space and remove the cover paper.

5. Tilt the front of the yoke right or left to obtain better convergence in circumference. (See Figure 2).

6. Keep the yoke position and put another wedge in eight upper space. Remove the cover paper and stick the wedge on the display tube to fix the yoke.

7. Detach the temporarily mounted wedge and put it in another upper space. Stick it on the display tube to fix the yoke.

8. After attaching three wedges, recheck overall convergence. Tighten the screw firmly to fix the yoke and check the yoke is firm.

9. Stick 3 adhesive tapes on the wedges as shown in Figure 2.

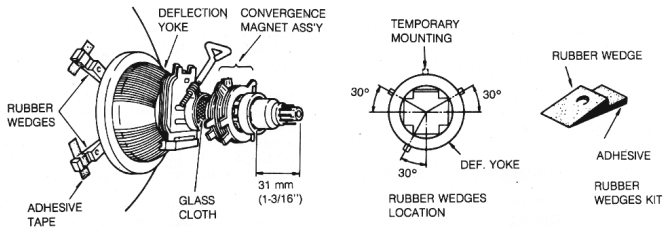

[Figure 2] Circumference Convergent Adjustment

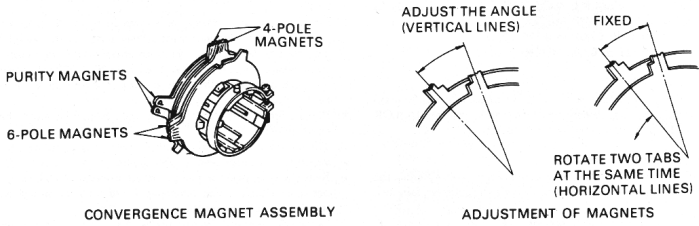

[Figure 3] Center Convergent Adjustment

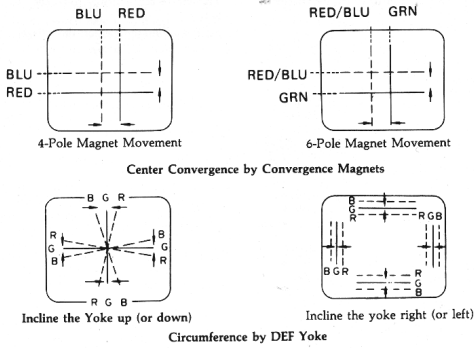

[Figure 4] Dot Movement Pattern

BLOCK DIAGRAM

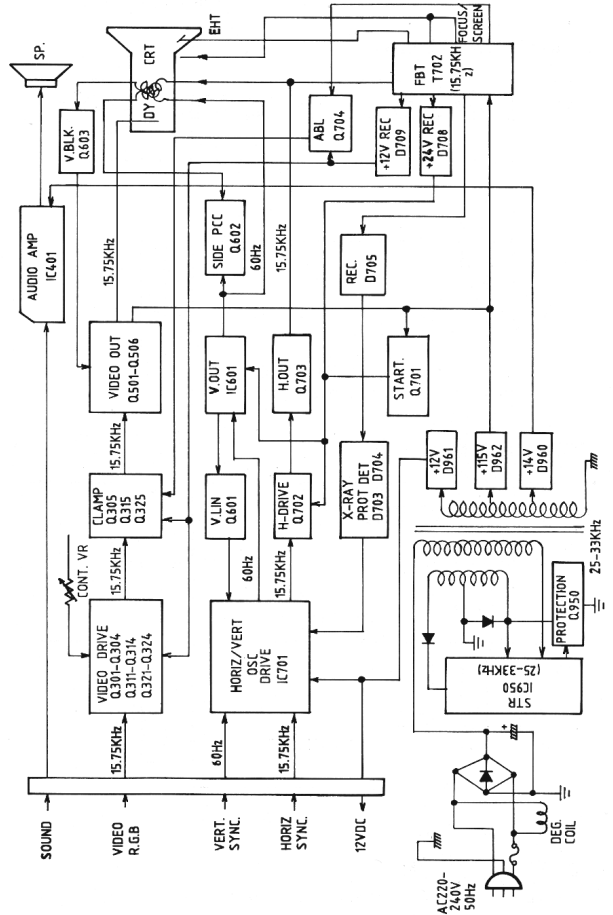

SCHEMATIC DIAGRAM

CA-3 CHASSIS SCHEMATIC DIAGRAM

IMPORTANT SAFETY NOTICE

THE COMPONENT IDENTIFIED BY SHADING OR THE INTERNATIONAL SYMBOL Δ ON THIS SCHEMATIC DIAGRAM INCORPORATES SPECIAL FEATURES IMPORTANT FOR PROTECTION FROM RADIATION FIRE AND ELECTRICAL SHOCK HAZARDS, WHEN SERVICING IT IS ESSENTIAL THAT ONLY MANUFACTURER'S SPECIFIED PARTS BE USED FOR THESE CRITICAL COMPONENTS.

NOTES: UNLESS OTHERWISE SPECIFIED

1. ALL RESISTORS ARE 1/4W.
2. ALL CAPACITORS ARE SHOWN IN μF P-10 $^{\circ}F$.
3. COIL UNIT OF INDUCTANCE IS μH

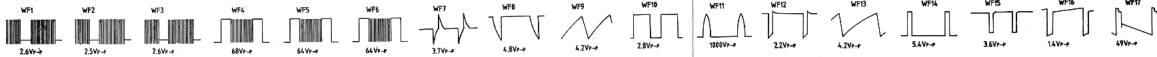
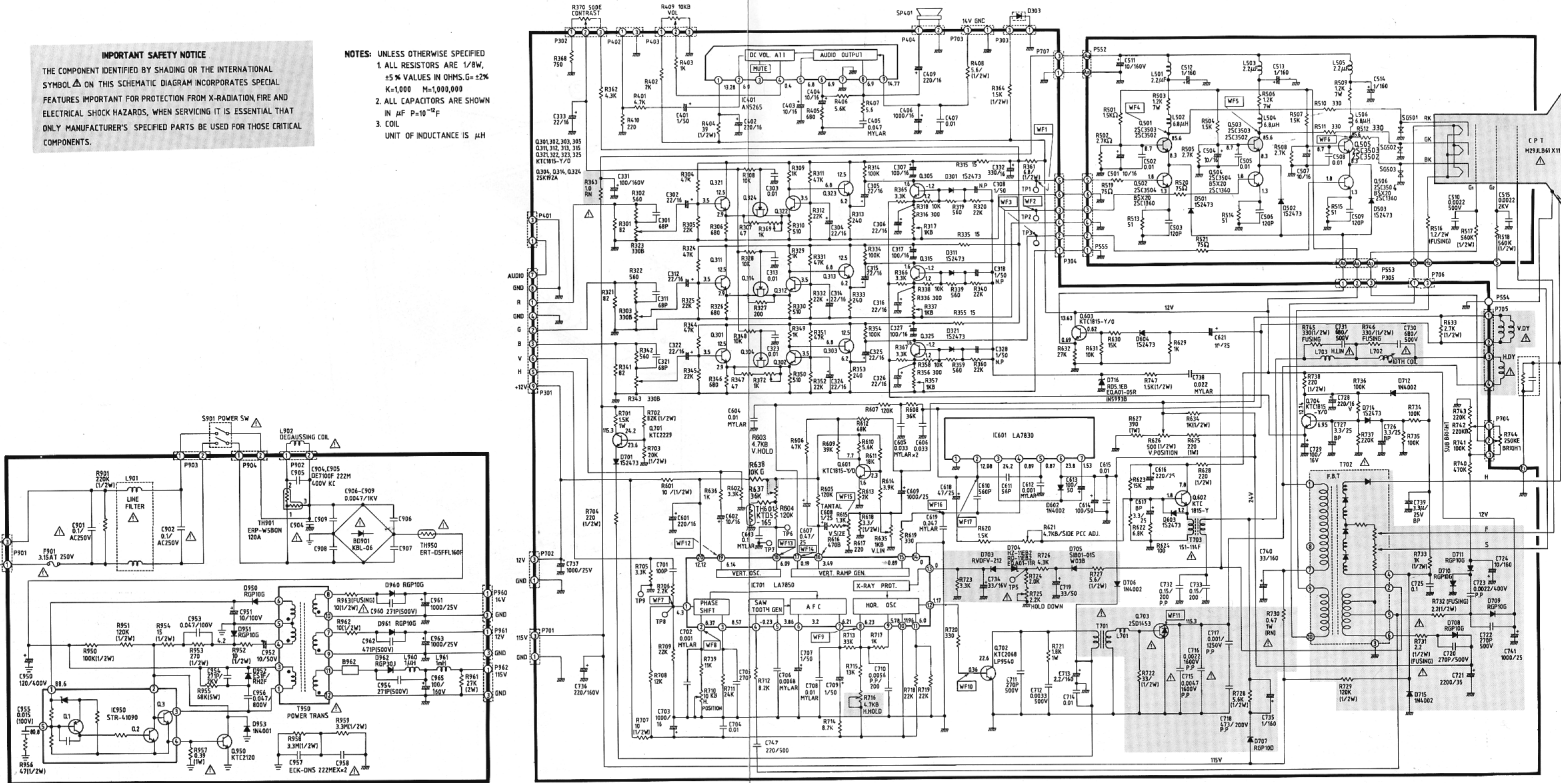

P/N 484 - 257A

EXPLODED VIEW DIAGRAM

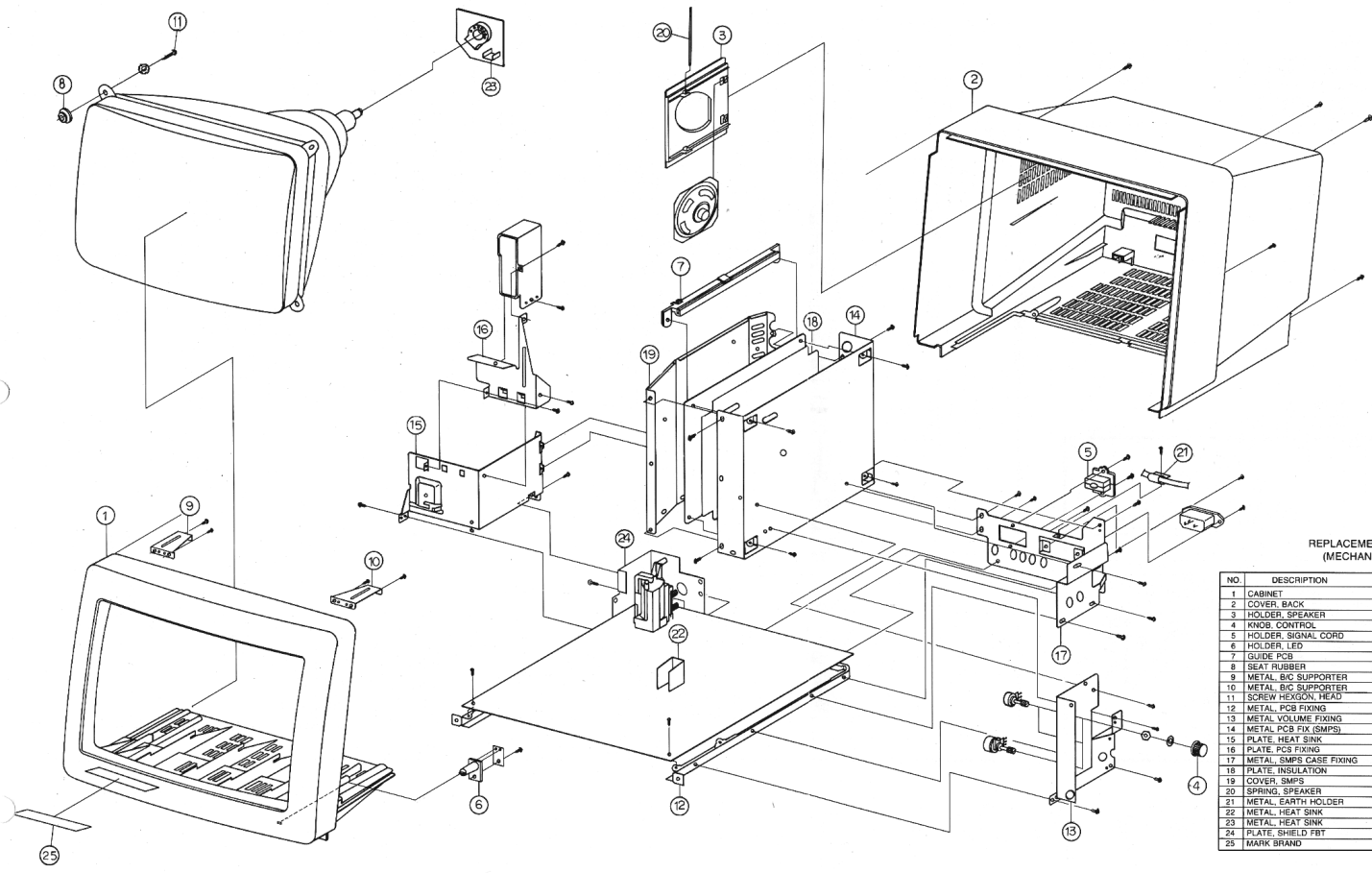

REPLACEMENT PARTS LIST
(MECHANICAL PARTS)

NO.	DESCRIPTION	PART NO.	MATERIAL	QTY	REMARK
1	CABINET	301-188A	HIPS	1	
2	COVER, BACK	303-721A	HIPS	1	
3	HOLDER, SPEAKER	343-028A	HIPS	1	
4	KNOB, CONTROL	440-488D	HIPS	3	
5	HOLDER, SIGNAL CORD	341-068A	HIPS	1	
6	HOLDER, LED	341-235A	HIPS	1	
7	GUIDE, PCB	348-028A	HIPS	1	
8	SEAT, RUBBER	327-032A	NEOPRENE	4	
9	METAL, B/C SUPPORTER	430-503A		1	
10	METAL, B/C SUPPORTER	430-503A		1	
11	SCREW, HEXAGON, HEAD	430-488B		4	
12	METAL, PCB FIXING	430-504B		1	
13	METAL, PCB FIXING	430-504B		1	
14	METAL, PCB FIX (SMPS)	430-550B		1	
15	PLATE, HEAT SINK	407-399A		1	
16	PLATE, PCB FIXING	407-391A		1	
17	METAL, SMPS CASE FIXING	430-501C		1	
18	PLATE, INSULATION	407-142A		1	
19	COVER, SMPS	303-727A		1	
20	SPRING, SPEAKER	320-012B		1	
21	METAL, EARTH HOLDER	430-554A		1	
22	METAL, HEAT SINK	430-269A		1	
23	METAL, HEAT SINK	430-239A		3	
24	PLATE, SHIELD, FB	407-602A		1	
25	MARK, BRAND	416-192B		1	

TIMING CHART

HORIZONTAL TIMING

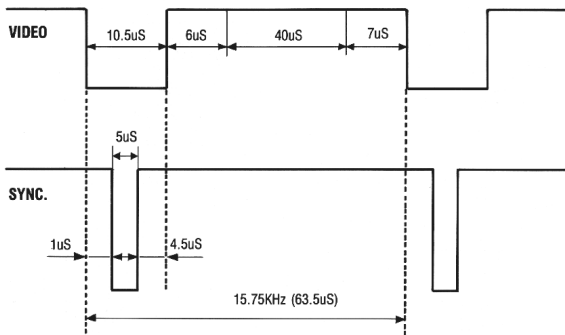

VERTICAL TIMING

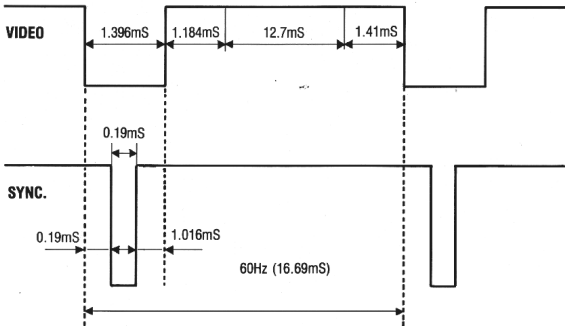

*** NOTES**

1. SIGNAL INPUT LEVEL: 1V_{p-p}
2. TIME TOLERANCE: ±0.1%
3. THE MONITOR IS ADJUSTED ACCORDING TO THE ABOVE TIMINGS AND FREQUENCY.

TROUBLE SHOOTING CHART

A. NO CHARACTER

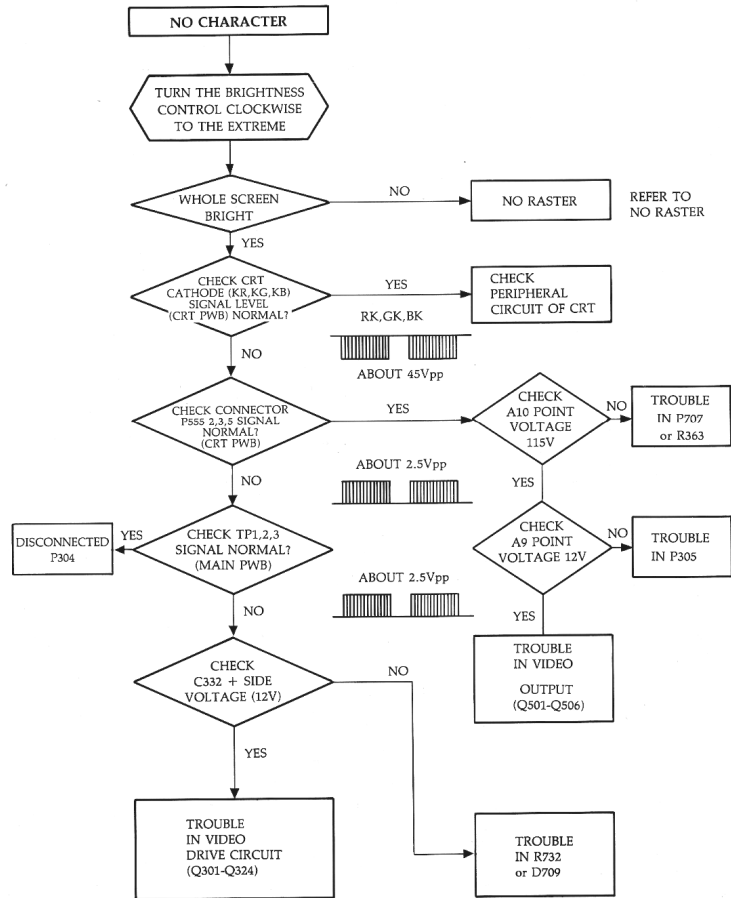

B. NO POWER

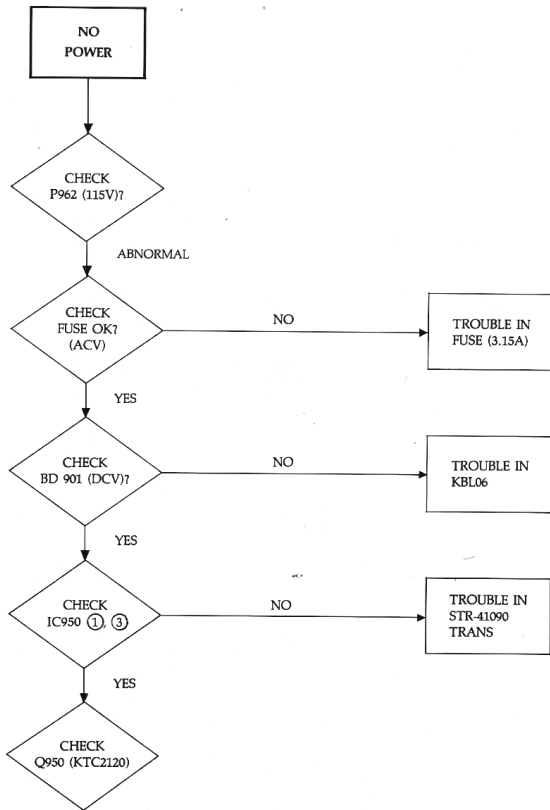

C. NO RASTER

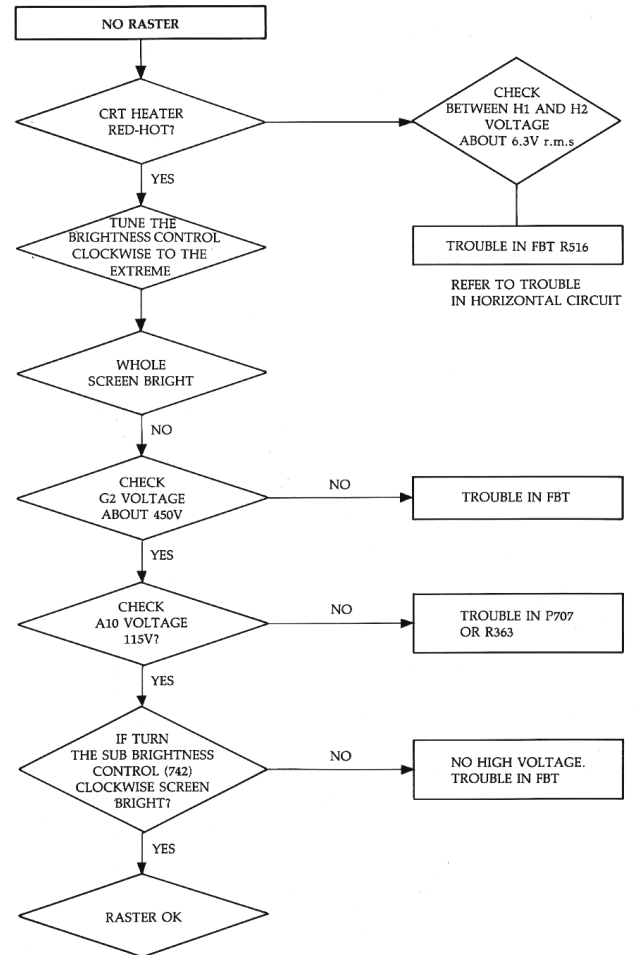

C-1. TROUBLE IN HORIZ OUT CIRCUIT

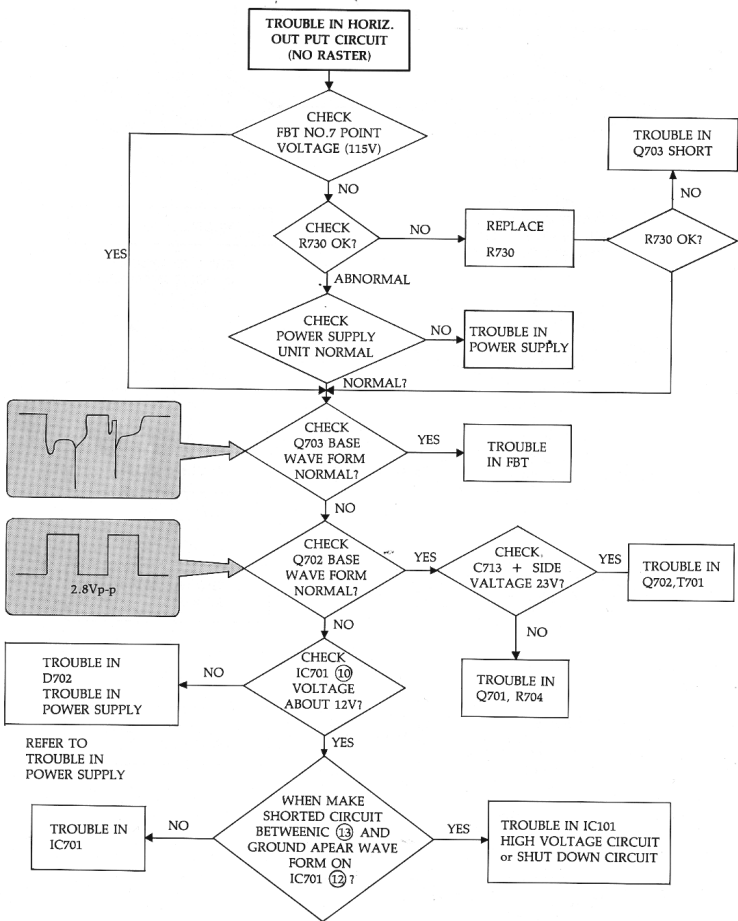

D.

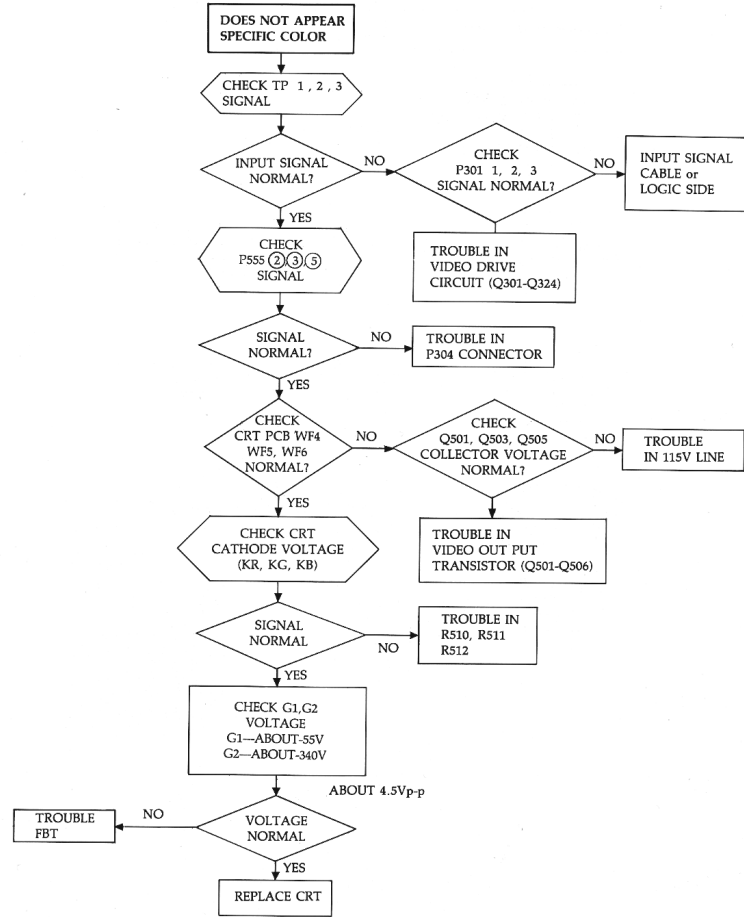

E. NO HORIZONTAL SYNC.

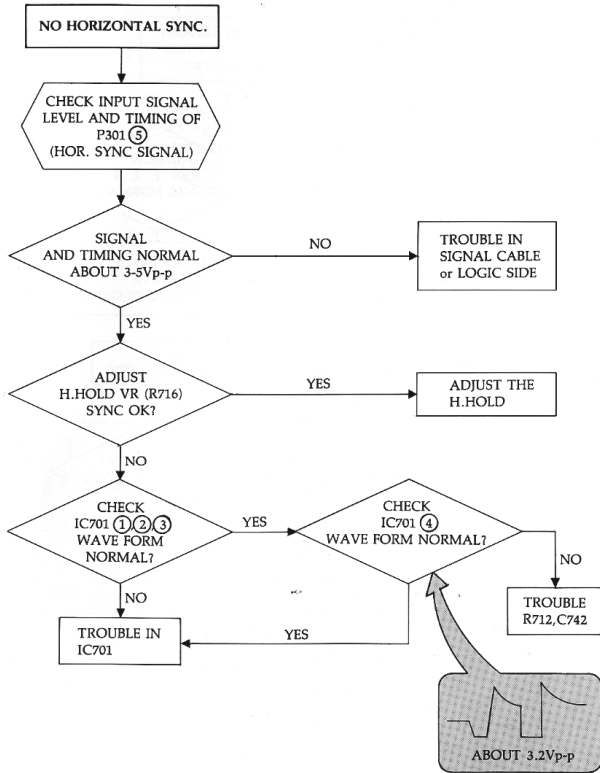

F. NO VERTICAL SYNC.

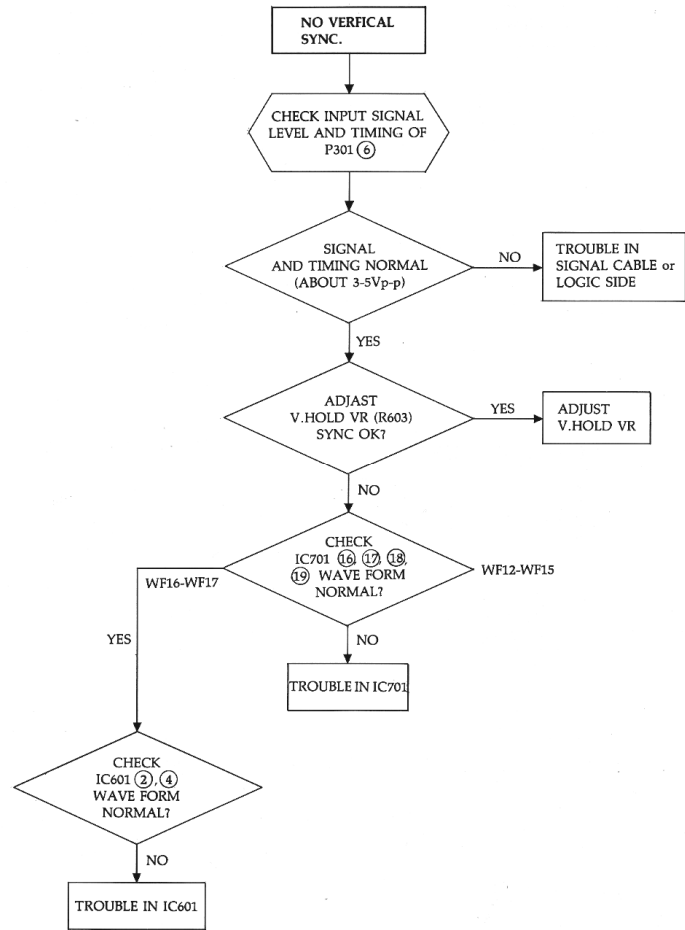

G. CONVERGENCE IS BAD

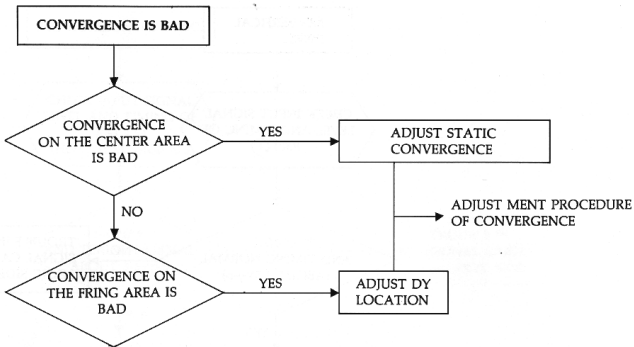

H. FOCUSING PROBLEM

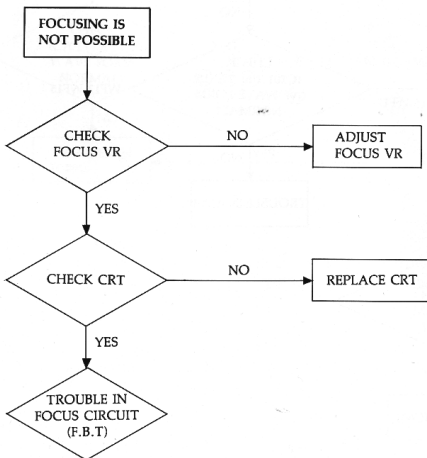

- 18 -

I. VERTICAL PIN COMPENSATION (V.PCC) IS BIG

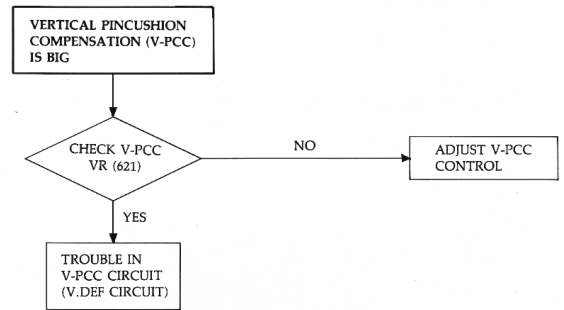

J. HORIZONTAL LINE

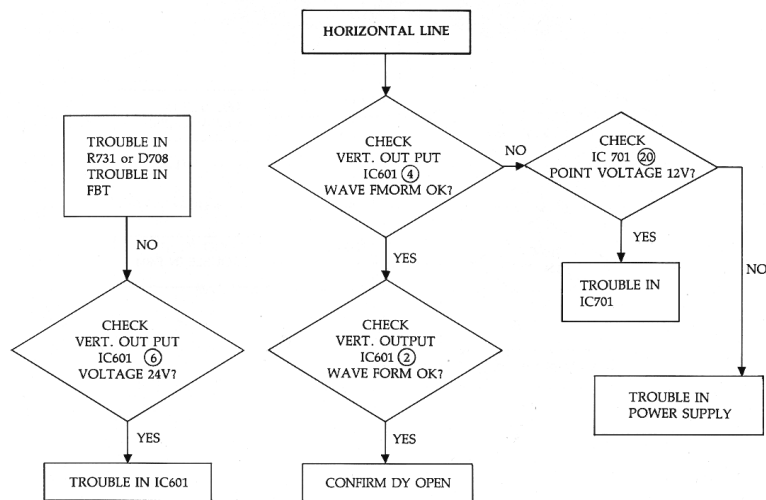

- 19 -

K. NO SOUND

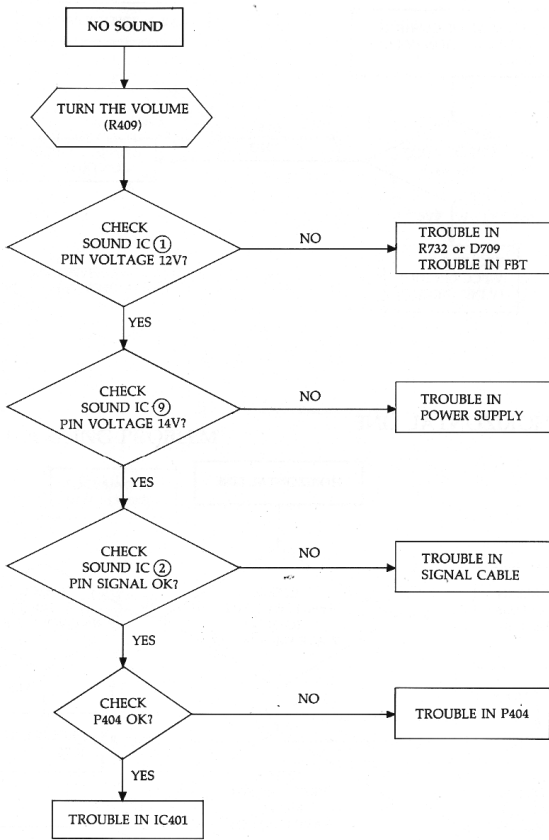

CHASSIS IMPORTANT PARTS

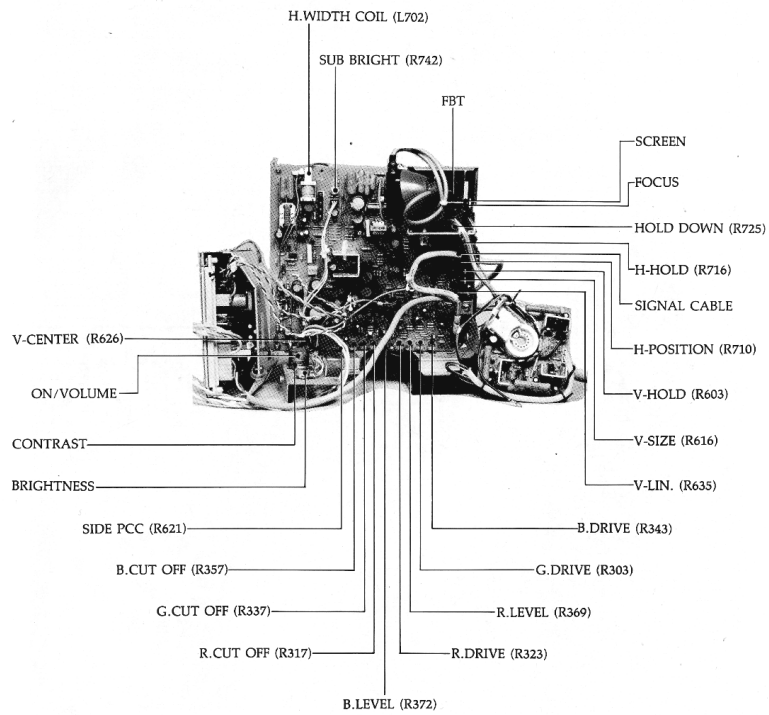

COMPONENT OF P.C.B

1. MAIN P.C.B LAYOUT

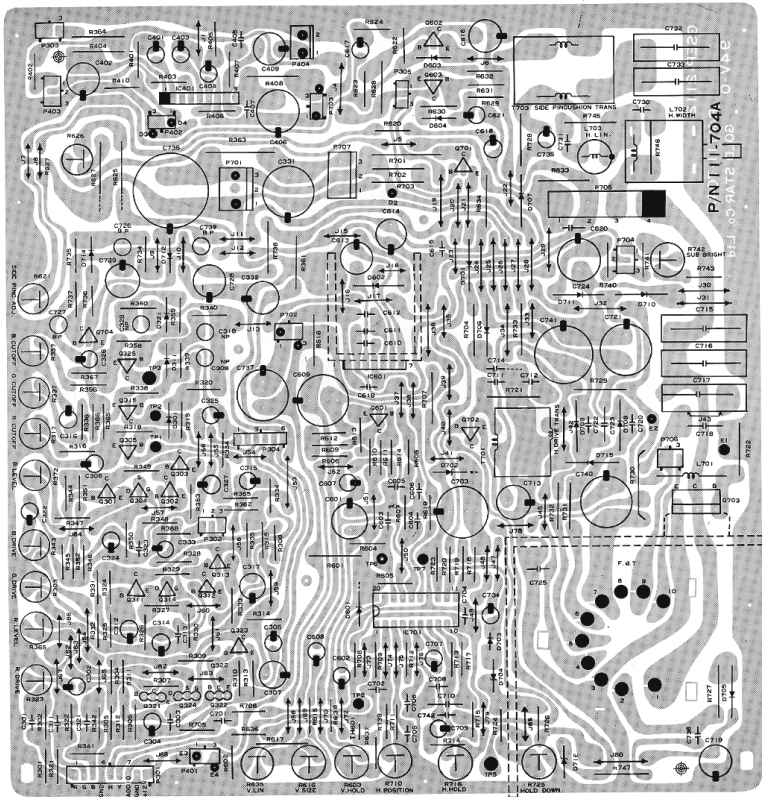

2. C.P.T. P.C.B LAYOUT

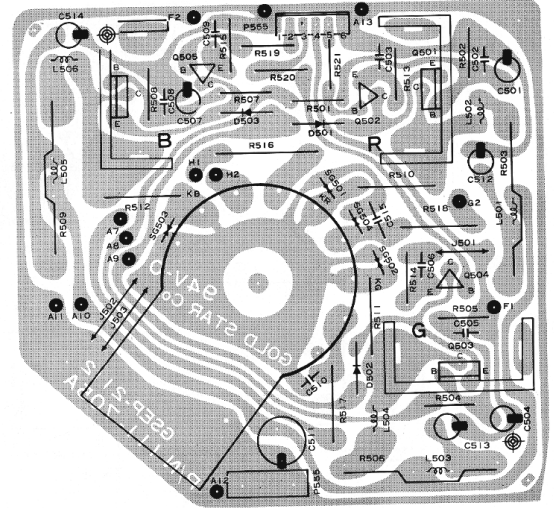

3. POWER P.C.B LAYOUT

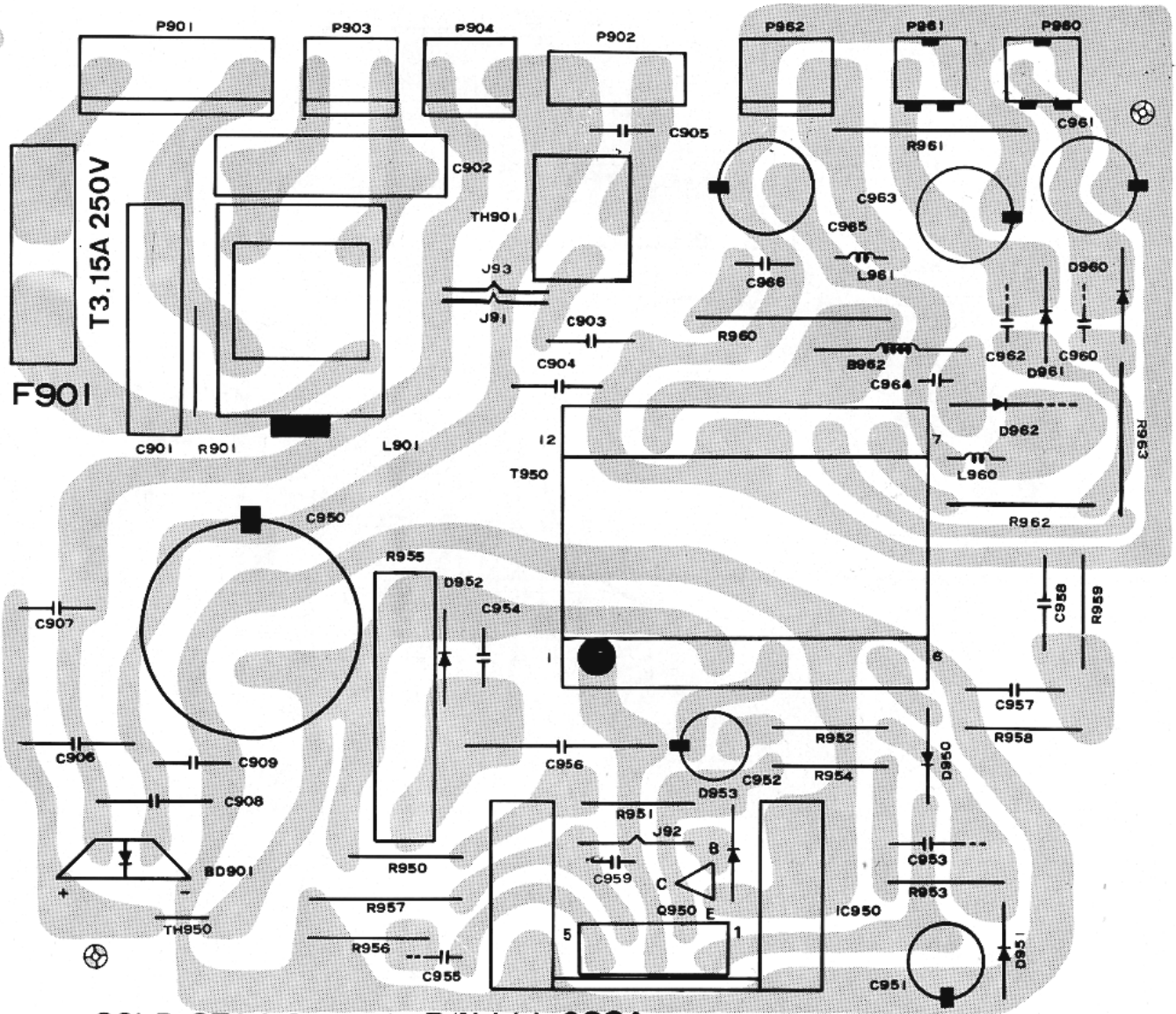

GOLD STAR Co., Ltd P/N 111-069A

REPLACEMENT PARTS LIST

CAUTION: Before replacing any these components, read carefully the "SAFETY PRECAUTION" on page 2.
Do not degrade the safety of the receiver through improper servicing.

ABBREVIATIONS: Capacitors CC: Ceramic (TC), CE: Chemical, CK: Ceramic (Hi-K), MPP: Metalized Polypropylenes,
Resistors RD: Carbon Film, RS: Metal Oxide Film,
RN: Metal Film, RV: Variable, RF: Fusing, SR: Semifix.

(All CC and Plastic Capacitors are $\pm 50\%$, 50 Volts and all resistor, $\pm 5\%$, 1/8 unless other wise noted).
: Recommend Service Parts

1. MAIN P.W.B

LOCATION NUMBER	PART NO.	DESCRIPTION
RESISTOR		
R301	01157071	RD, 1/8W 82 ohm
R302	01157091	RD, 1/8W 560 ohm
R303	180-098M	SR29R 330B
R304	01157131	RD, 1/8W 47K ohm
R305	01157129	RD, 1/8W 22K ohm
R306	01157093	RD, 1/8W, 680 ohm
R307	01157065	RD, 1/8W 47 ohm
R308	01157121	RD, 1/8W 10K ohm
R309	01157097	RD, 1/8W 1K ohm
R310	01157090	RD, 1/8W 510 ohm
R311	01157131	RD, 1/8W 47K ohm
R312	01157129	RD, 1/8W 22K ohm
R313	01157082	RD, 1/8W 240 ohm
R314	01157145	RD, 1/8W 100K ohm
R315	01157053	RD, 1/8W 15 ohm
R316	01157084	RD, 1/8W 300 ohm
R317	180-098D	SR29R 1KB
R318	01157121	RD, 1/8W 10K ohm
R319	01157091	RD, 1/8W 560 ohm
R320	01157129	RD, 1/8W 22K ohm
R321	01157071	RD, 1/8W 82 ohm
R322	01157091	RD, 1/8W 560 ohm
R323	180-098M	SR29R 330B
R324	01157131	RD, 1/8W 47K ohm
R325	01157129	RD, 1/8W 22K ohm
R326	01157093	RD, 1/8W 680 ohm
R327	01157080	RD, 1/8W 200 ohm
R328	01157121	RD, 1/8W 10K ohm
R329	01157097	RD, 1/8W 1K ohm
R330	01157090	RD, 1/8W 510 ohm
R331	01157131	RD, 1/8W 47K ohm
R332	01157129	RD, 1/8W 22K ohm
R333	01157082	RD, 1/8W 240 ohm
R334	01157145	RD, 1/8W 100K ohm
R335	01157053	RD, 1/8W 15 ohm
R336	01157084	RD, 1/8W 300 ohm
R337	180-098D	SR29R 1KB
R338	01157121	RD, 1/8W 10K ohm
R339	01157091	RD, 1/8W 560 ohm
R340	01157129	RD, 1/8W 22K ohm
R341	01157071	RD, 1/8W 82 ohm
R342	01157091	RD, 1/8W 560 ohm

LOCATION NUMBER	PART NO.	DESCRIPTION
R343	180-098M	SR29R 330B
R344	01157131	RD, 1/8W 47K ohm
R345	01157129	RD, 1/8W 22K ohm
R346	01157093	RD, 1/8W 680 ohm
R347	01157065	RD, 1/8W 47 ohm
R348	01157121	RD, 1/8W 10K ohm
R349	01157097	RD, 1/8W 1K ohm
R350	01157090	RD, 1/8W 510 ohm
R351	01157131	RD, 1/8W 47K ohm
R352	01157129	RD, 1/8W 22K ohm
R353	01157082	RD, 1/8W 240 ohm
R354	01157145	RD, 1/8W 100K ohm
R355	01157053	RD, 1/8W 15 ohm
R356	01157084	RD, 1/8W 300 ohm
R357	180-098D	SR29R 1KB
R358	01157121	RD, 1/8W 10K ohm
R359	01157091	RD, 1/8W 560 ohm
R360	01157129	RD, 1/8W 22K ohm
R361	01154045	RD, 1/2W 6.8 ohm
R362	01157110	RD, 1/8W 3.6K ohm
R363	01521025	RN, 1W 1 ohm
R364	01154101	RD, 1/2W 1.5K ohm
R365	01157109	RD, 1/8W 3.3K ohm
R366	01157109	RD, 1/8W 3.3K ohm
R367	01157109	RD, 1/8W 3.3K ohm
R368	01157094	RD, 1/8W 750 ohm
R369	180-098D	SR29R 1KB
R370	180-071G	VAR 500E
R372	180-098D	SR29R 1KB
R401	01157113	RD, 1/8W 4.7K ohm
R402	01157104	RD, 1/8W 2K ohm
R403	01157097	RD, 1/8W 1K ohm
R404	01154063	RD, 1/2W 39 ohm
R405	01157093	RD, 1/8W 680 ohm
R406	01157115	RD, 1/8W 5.6K ohm
R407	01157043	RD, 1/8W 5.6 ohm
R408	01154043	RD, 1/2W 5.6 ohm
R409	140-021A	RV, 10KB
R410	01142081	RD, 1/8W 220 ohm
R601	01154049	RD, 1/2W 10 ohm
R602	01157109	RD, 1/8W 3.3K ohm
R603	180-098E	SR29R 4.7KB
R604	01157147	RD, 1/8W 120K ohm
R605	01157147	RD, 1/8W 120K ohm

PRODUCT SAFETY NOTE: Components shaded have special characteristics important to safety. Before replacing any of these components, read carefully the **PRODUCT SAFETY NOTICE** of this service manual. Don't degrade the safety of the receiver through improper servicing.

LOCATION NUMBER	PART NO.	DESCRIPTION
R606	01157137	RD, 1/8W 47K ohm
R607	01157147	RD, 1/8W 120K ohm
R608	01157134	RD, 1/8W 36K ohm
R609	01157135	RD, 1/8W 39K ohm
R610	01157115	RD, 1/8W 5.6K ohm
R611	01157127	RD, 1/8W 18K ohm
R612	01157141	RD, 1/8W 68K ohm
R613	01157104	RD, 1/8W 2K ohm
R614	01157111	RD, 1/8W 3.9K ohm
R615	01157100	RD, 1/8W 1.3K ohm
R616	180-098F	SR29R 470B
R617	01157081	RD, 1/8W 220 ohm
R618	01154037	RD, 1/2W 3.3 ohm
R619	01157085	RD, 1/8W 330 ohm
R620	01157101	RD, 1/8W 1.5K ohm
R621	180-098E	SR29R 4.7KB
R622	01157117	RD, 1/8W 6.8K ohm
R623	01157125	RD, 1/8W 15K ohm
R624	01157073	RD, 1/8W 100 ohm
R625	01314081	RS, 1W 220 ohm
R626	180-293B	SR9D 470 ohm
R627	01314087	RS, 1W 390 ohm
R628	01154081	RD, 1/2W 220 ohm
R629	01157097	RD, 1/8W 1K ohm
R630	01157125	RD, 1/8W 15K ohm
R631	01157121	RD, 1/8W 10K ohm
R632	01157131	RD, 1/8W 27K ohm
R633	01154107	RD, 1/2W 2.7K ohm
R634	01154097	RD, 1/2W 1.0K ohm
R635	180-098D	SR29R 1KB
R636	01157097	RD, 1/8W 1K ohm
R637	01157134	RD, 1/8W 36K ohm
R638	01160121	RD, 1/8W 10K ohm G
TH601	163-014B	THERMISTOR KTDS-165
R701	01332101	RS, 1W 1.5K ohm
R702	01154143	RD, 1/2W 82K ohm
R703	01154128	RD, 1/2W 20K ohm
R704	01325081	RS, 1/2W 220 ohm
R705	01157109	RD, 1/8W 3.3K ohm
R706	01157105	RD, 1/8W 2.2K ohm
R707	01154049	RD, 1/2W 10 ohm
R708	01157123	RD, 1/8W 12K ohm
R709	01157129	RD, 1/8W 22K ohm
R710	180-098B	SR29R 10KB
R711	01157130	RD, 1/8W 24K ohm
R712	01157119	RD, 1/8W 8.2K ohm
R713	01157133	RD, 1/8W 33K ohm
R714	01157119	RD, 1/8W, 8.2K ohm
R715	01157124	RD, 1/8W 13K ohm
R716	180-098E	SR29R 4.7KB
R717	01157097	RD, 1/8W 1K ohm
R718	01157129	RD, 1/8W 22K ohm
R719	01157129	RD, 1/8W 22K ohm
R720	01157085	RD, 1/8W 330 ohm
R721	01332103	RD, 1W 1.8K ohm

-30-

PRODUCT SAFETY NOTE: Components shaded have special characteristics important to safety. Before replacing any of these components, read carefully the **PRODUCT SAFETY NOTICE** of this service manual. Don't degrade the safety of the receiver through improper servicing.

LOCATION NUMBER	PART NO.	DESCRIPTION
C401	08110507	CE, 1uF 50V
C402	02140321	CE, 220uF 16V
C403	08110313	CE, 10uF 16V
C404	08110313	CE, 10uF 16V
C405	08700335	CQ, 473pF +10%
C406	02140325	CE, 1000uF 16V
C407	08200972	CK, 103pF +80%, -20%
C409	02140321	CE, 220uF 16V
C601	02140321	CE, 220uF 16V
C602	08110313	CE, 10uF 16V
C603	02706537	CQ, 104pF +10%, 100V
C604	08700334	CQ, 103pF +10%
C605	08700334	CQ, 333pF +10%
C606	08700334	CQ, 333pF +10%
C607	08110505	CE, 0.47uF 50V
C608	181-033J	TANTAL 1uF 25V
C609	02140425	CE, 1000uF 25V
C610	08300754	CC, 560pF +5%
C611	08300730	CC, 560pF +5%
C612	08700319	CQ, 102pF +10%
C613	02140519	CE, 100uF 50V
C614	02140519	CE, 100uF 50V
C615	08200972	CK, 103pF +80% -20%
C616	02140421	CE, 220uF 25V
C617	181-098A	BP, 3.3uF 25V
C618	08110417	CE, 47uF 25V
C619	08700335	CQ, 473pF +10%
C621	08110413	CE, 10uF 25V
C701	08300736	CC, 100pF +5%
C702	02706519	CQ, 102pF +10%, 100V
C703	02140325	CE, 100uF 16V
C704	08200972	CK, 103pF +80%, -20%
C705	08300746	CC, 270pF +5%
C706	02706529	CQ, 682pF +10%, 100V
C707	08110507	CE, 1uF 50V
C708	08700331	CQ, 103pF +10%
C709	08110507	CE, 1uF 50V
C710	181-059T	PP, 562pF +10%, 200V
C711	08201046	CK, 270pF +10%, 500V
C712	02201066	CK, 332pF +10%, 500V
C713	08110709	CE, 2.2uF 160V
C714	08700331	CQ, 103pF +10%, 100V
C715	181-083E	PP, 472pF +5%, 1600V
C716	181-083A	PP, 222pF +5%, 1600V
C717	181-082A	PP, 102pF +10%, 1250V
C718	181-059Z	PP, 473pF +50%, 200V
C719	08110516	CE, 33uF 50V
C720	08201046	CK, 270pF +10%, 50V
C721	181-081H	CE, 220uF 35V
C722	08201046	CK, 270pF +10%, 500V
C723	181-060K	PP, 222pF +5%, 400V
C724	02140713	CE, 10uF 160V
C725	02706537	CQ, 104pF +10%, 100V
C726	181-098A	BP, 3.3uF 25V
C727	181-098A	BP, 3.3uF 25V
C728	02140321	CE, 220uF 16V

-31-

LOCATION NUMBER	PART NO.	DESCRIPTION
C729	08110319	CE, 100uF 16V
C730	0821056	CK, 680pF +10%, 500V
C731	0621056	CK, 680pF +10%, 500V
C732	181-059E	PP, 154pF +10%, 200V
C733	181-059E	PP, 154pF +10%, 200V
C734	08110316	CE, 33uF 16V
C735	08110707	CE, 1uF 160V
C736	181-134A	CE, 220uF 160V
C737	02140425	CE, 1000uF 25V
C738	08700333	CQ, 223pF +10%
C739	181-098A	BP, 3.3uF 25V
C740	181-102A	CE, 33uF 160V
C741	02140425	CE, 1000uF 25V
C742	08201044	CK, 220pF +10% 500V
TR		
Q301	06120169	KTC1815-Y
Q302	06120169	KTC1815-Y
Q303	06120169	FET, 2SK192A-Y
Q304	06100017	KTC1815-Y
Q305	06120169	KTC1815-Y
Q311	06120169	KTC1815-Y
Q312	06120169	KTC1815-Y
Q313	06120169	KTC1815-Y
Q314	06100017	FET, 2SK192A-Y
Q315	06120169	KTC1815-Y
Q321	06120169	KTC1815-Y
Q322	06120169	KTC1815-Y
Q323	06120169	KTC1815-Y
Q324	06100017	FET, 2SK192A-Y
Q325	06120169	KTC1815-Y
Q601	06120169	KTC1815-Y
Q602	06120169	KTC1815-Y
Q603	06120169	KTC1815-Y
Q701	06120161	KTC2229-0
Q702	06120221	KTC2068F-A1
Q703	06130118	2SD1453
Q704	06120169	KTC1815-Y
DIODE		
D301	06200073	1S2473
D303	06210019	LED, GREEN (SLP-262B)
D311	06200073	1S2473
D321	06200073	1S2473
D602	06200061	1N4002GP
D603	06200073	1S2473
D604	06200073	1S2473
D701	06200073	1S2473
D703	164-003A	VARISTOR, RVDFV-212
D704	06220159	ZENER, EOA01-11R
D705	06200207	SB01-01V
D706	06200061	1N4002GP
D707	06200072	RGP100 (F,R)
D708	06200266	RGP100 (F,R)
D709	06200266	RGP100 (F,R)

PRODUCT SAFETY NOTE: Components shaded have special characteristics important to safety. Before replacing any of these components, read carefully the PRODUCT SAFETY NOTICE of this service manual. Don't degrade the safety of the receiver through improper servicing.

LOCATION NUMBER	PART NO.	DESCRIPTION
D710	06200266	RGF10D (F.R)
D711	06200266	RGF10D (F.R)
D712	06200061	1N4002GP
D714	06200073	1S2473
D715	06200061	1N4002GP
D716	06220131	RD5.1EB2
I.C		
IC401	06300226	IC, AN5265 (SOUND)
IC701	06300402	IC, LA7850 (SYNC)
IC801	06300360	IC, LA7830
COIL & TRANS		
T701	151-116B	H.D.T
T702	154-120A	KF4825G
T703	151-114F	TRANS SIDE PCC
L701	125-022B	CORE, FERRITE
L702	150-369B	COIL WIDTH
L703	150-224H	COIL LINEARITY
2. C.P.T P.W.B		
RESISTOR		
R501	01157101	RD, 1/8W 1.5K ohm
R502	01157107	RD, 1/8W, 2.7K ohm
R503	180-304B	RS, 7W 1.2K ohm
R504	01157101	RD, 1/8W 1.5K ohm
R505	01157107	RD, 1/8W 2.7K ohm
R506	180-304B	RS, 7W 1.2K ohm
R507	01157101	RD, 1/8W 1.5K ohm
R508	01157107	RD, 1/8W 2.7K ohm
R509	180-304B	RS, 7W 1.2K ohm
R510	01154085	RD, 1/2W 330 ohm
R511	01154085	RD, 1/2W 330 ohm
R512	01154085	RD, 1/2W 330 ohm
R513	01157066	RD, 1/8W 51 ohm
R514	01157066	RD, 1/8W 51 ohm
R515	01157066	RD, 1/8W 51 ohm
R516	180-140P	RF, 2W 1.2 ohm
R517	01154163	RD, 1/2W 560K ohm
R518	01154163	RD, 1/2W 560K ohm
R519	01157070	RD, 1/8W 75 ohm
R520	01157070	RD, 1/8W 75 ohm
R521	01157070	RD, 1/8W 75 ohm
CAPACITOR		
C501	02110313	CE, 10uF 16V
C502	02200972	CK, 103pF +80%, -20%
C503	02300138	CC, 120pF +5%
C504	02110313	CE, 10uF 16V
C505	02200972	CK, 103pF +80%, -20%
C506	02300138	CC, 120pF +5%
C507	02110313	CE, 10uF 16V
C508	02200972	CK, 103pF +80%, -20%
C509	02300138	CC, 120pF +5%
C510	02201064	CK, 223pF +10%, 500V

LOCATION NUMBER	PART NO.	DESCRIPTION
C511	02140713	CE, 10uF 160V
C512	02110707	CE, 1uF 160V
C513	02110707	CE, 1uF 160V
C514	02110707	CE, 1uF 160V
C515	02201364	CK, 222pF +10%, 2KV
TR		
Q501	06179489	2SC3503
Q502	06160019	BSX20
Q503	06179489	2SC3503
Q504	06160018	BSX20
Q505	06179489	2SC3503
Q506	06160018	BSX20
DIODE		
D501	06200073	1S2473
D502	06200073	1S2473
D503	06200073	1S2473
COIL		
L501	04030025	COIL PEAKING 2.2uH
L502	04030037	COIL PEAKING 6.8uH
L503	04030025	COIL PEAKING 2.2uH
L504	04030037	COIL PEAKING 6.8uH
L505	04030025	COIL PEAKING 2.2uH
L506	04030037	COIL PEAKING 6.8uH
SPARK GAP		
SG501	165-004A	SPARK GAP
SG502	165-004A	SPARK GAP
SG503	165-004A	SPARK GAP
MISCELLANEOUS		
CPT	381-086A	SOCKET, CPT
	112-843A	M23JL61X11
	150-373B	COIL, DEGAUSSING
3. POWER P.W.B		
RESISTOR		
R901	01154153	RD, 1/2W 220K ohm
R950	01154145	RD, 1/2W 100K ohm
R951	01154147	RD, 1/2W 120K ohm
R952	01154049	RD, 1/2W 10 ohm
R953	01154083	RD, 1/2W 270 ohm
R954	01154053	RD, 1/2W 15 ohm
R955	180-304C	RS, 5W 68K ohm
R956	01154085	RD, 1/2W 47 ohm
R957	01521015	RN, 1W 0.39 ohm
R958	180-289A	RC, ERC-122GK 335V
R959	180-289A	RC, ERC-122GK 335V
R961	01335131	RS, 2W 27K ohm
R962	01154049	RD, 1/2W 10 ohm
R963	180-140C	FUSING 0.5W 10 ohm
TH901	163-024A	PTC, ERP-W5BCN 120A
TH950	163-023A	NTC, ERC-D5FF L160P

PRODUCT SAFETY NOTE: Components shaded have special characteristics important to safety. Before replacing any of these components, read carefully the PRODUCT SAFETY NOTICE of this service manual. Don't degrade the safety of the receiver through improper servicing.

LOCATION NUMBER	PART NO.	DESCRIPTION
CAPACITOR		
C901	181-217A	MPP, ECQ-E2A104MW
C902	181-217A	MPP, ECQ-E2A104MW
C904	181-048J	DZ, 7100F 222M VAI-KC
C905	181-048J	DZ, 7100F 222M VAI-KC
C906	02201368	CK, 1KV 0.0047uF
C907	02201368	CK, 1KV 0.0047uF
C908	02201368	CK, 1KV 0.0047uF
C909	02201368	CK, 1KV 0.0047uF
C950	181-124G	CE, 400V 120uF
C951	02140613	CE, 100V 10uF
C952	02140513	CE, 50V 10uF
C953	181-218A	PE, 100V 0.047uF
C954	02201546	CK, 2KV 270pF
C955	02701532	CO, 93M 153KE
C956	181-143D	PP, 800V 0.047uF
C957	181-157A	ECK-DNS 222MEX
C958	181-157A	ECK-DNS 222MEX
C960	02201046	CK, 500V 270pF
C961	02140425	CE, 25V 1000pF
C962	02201052	CK, 500V 470pF
C963	02140425	CE, 25V 1000pF
C964	02201046	CK, 500V 270pF
C965	02140719	CE, 160V 100pF
TR & IC		
Q950	06120174	KTC2120-Y
IC950	06300404	IC, STR41090
DIODE		
D950	06200266	RGF10G
D951	06200266	RGF10G
D952	06200319	ESIF
D953	06220156	1N4001GP
D960	06200266	RGF10G
D961	06200266	RGF10G
D962	06200294	RGF30J
BD901	06200324	KBL-06
COIL & TRANS		
L901	150-314A	COIL, LINE FILTER 20mH
L960	150-287A	COIL, CHOKE 1.04uH
L961	150-235E	COIL, CHOKE 1mH (1A)
T950	151-240A	POWER TRANS
B962	122-022B	CORE FERRITE
FUSE		
F901	131-007P	FUSE 3 15A/250V