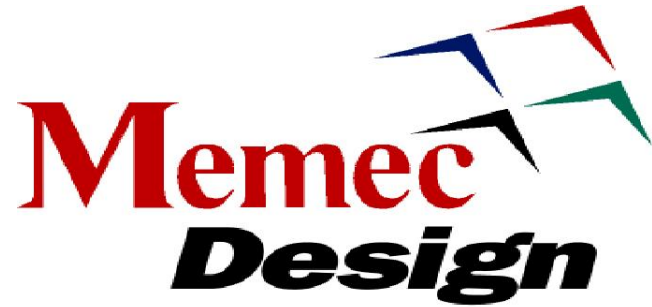
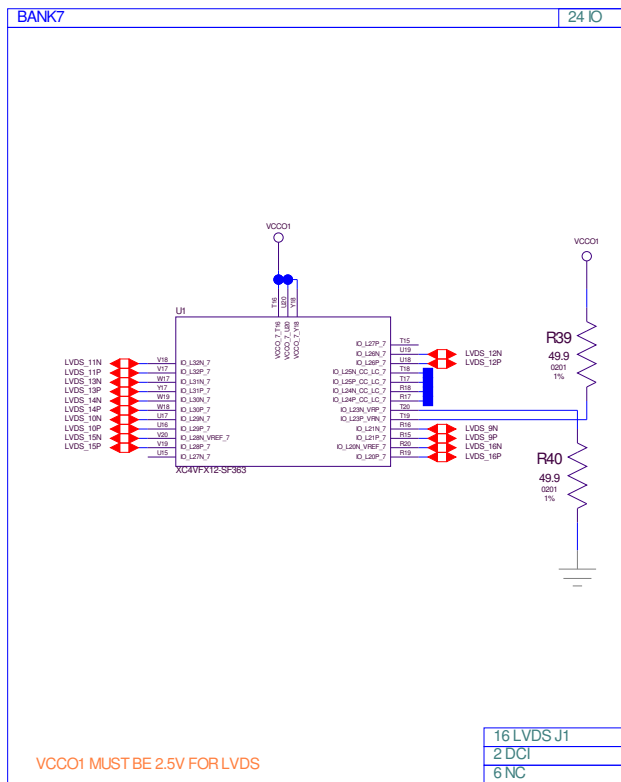
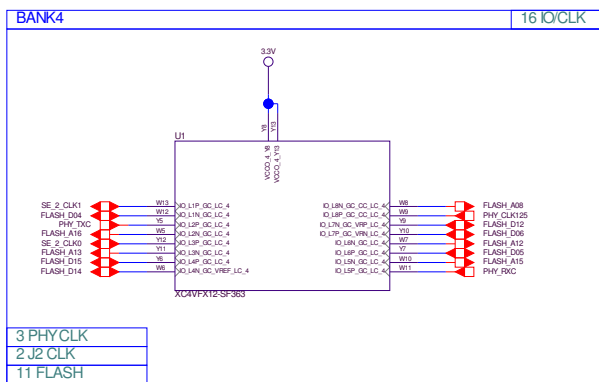
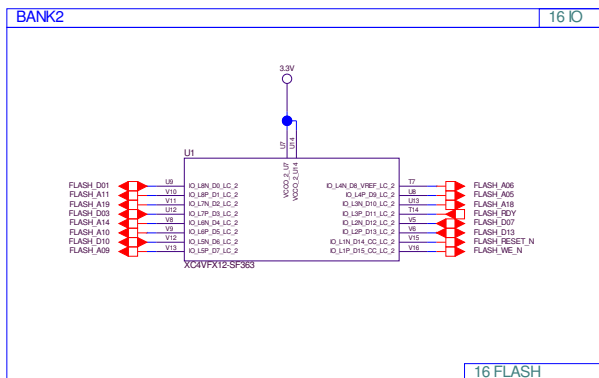
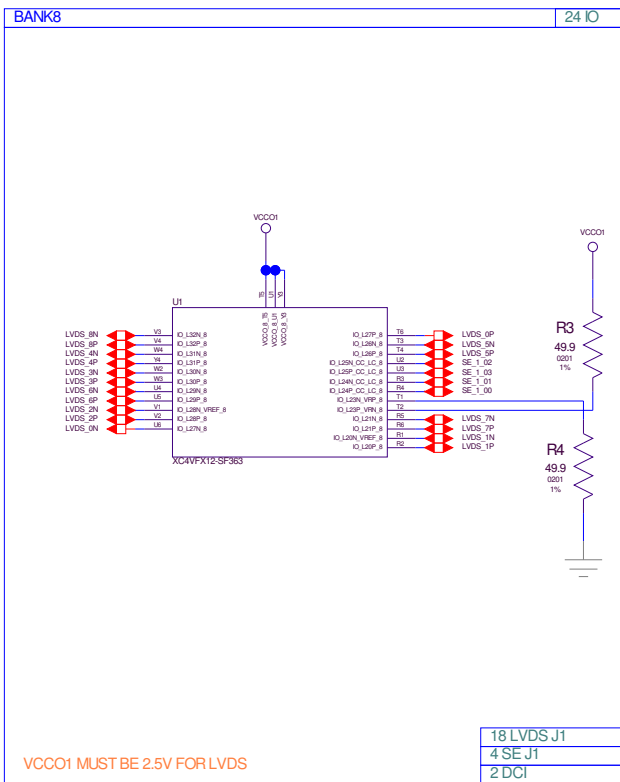
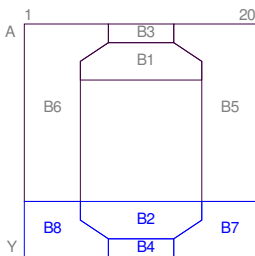
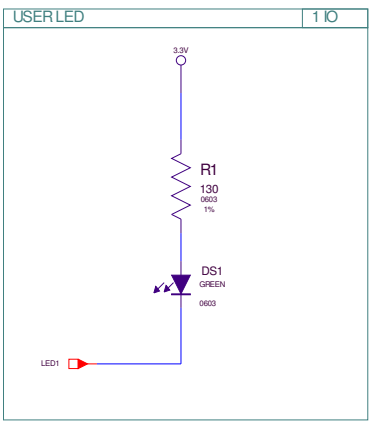
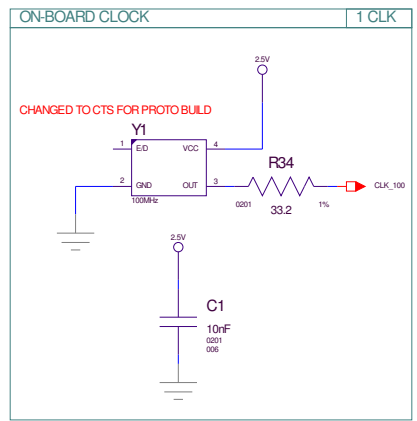
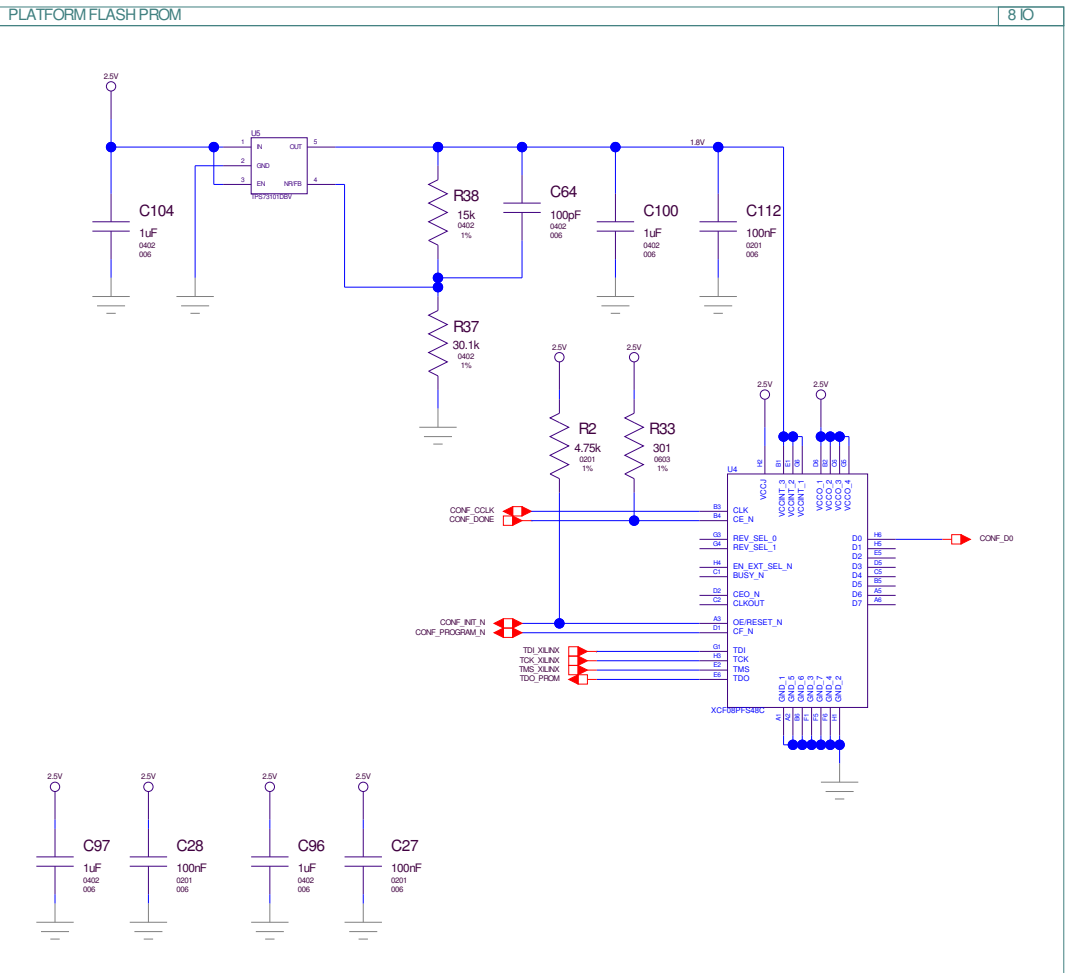
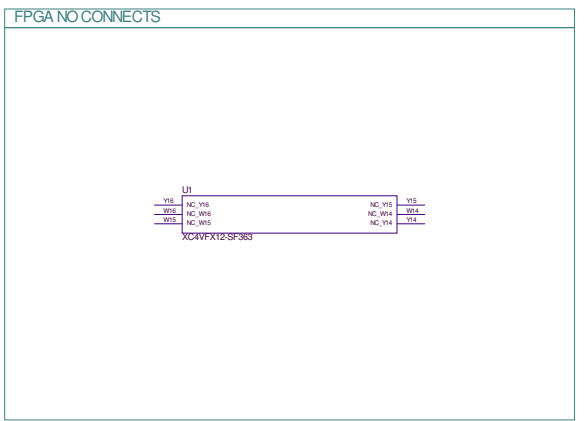
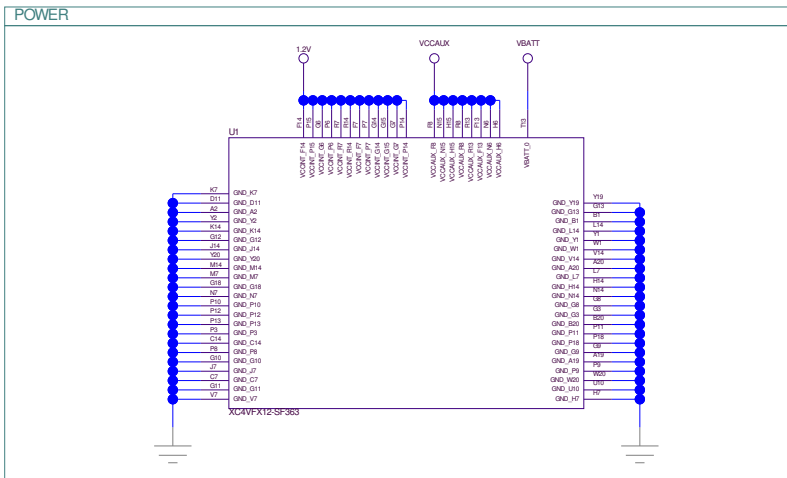
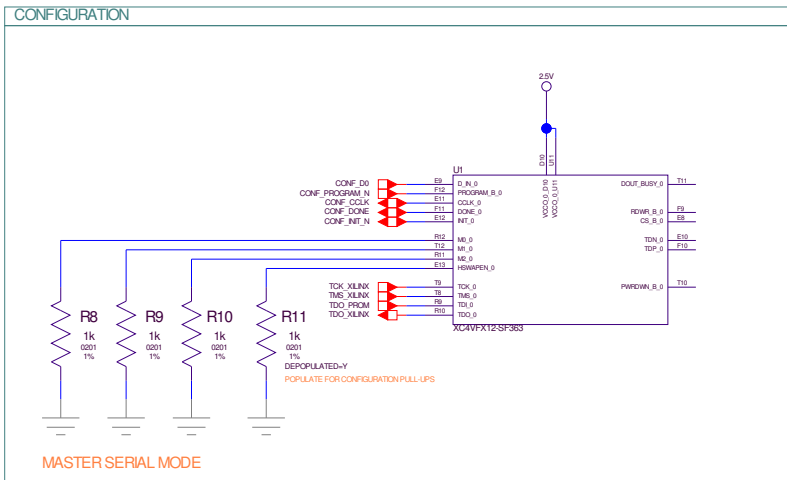

TABLE OF CONTENTS	
SHEET 1	COVER SHEET
SHEET 2	FPGA TOP
SHEET 3	FPGA BOTTOM
SHEET 4	FPGA AUX
SHEET 5	FPGA DECOUPLING
SHEET 6	MEMORY - DDR & FLASH
SHEET 7	ETHERNET
SHEET 8	HEADERS
SHEET 9	HISTORY & NON-ELECTRICAL & PLACEMENT



VIRTEX-4 FX12 MINI-MODULE
DS-BD-4VFX12MM1
REVISION 1





DONE LED

DONE LED MUST BE ON BASEBOARD

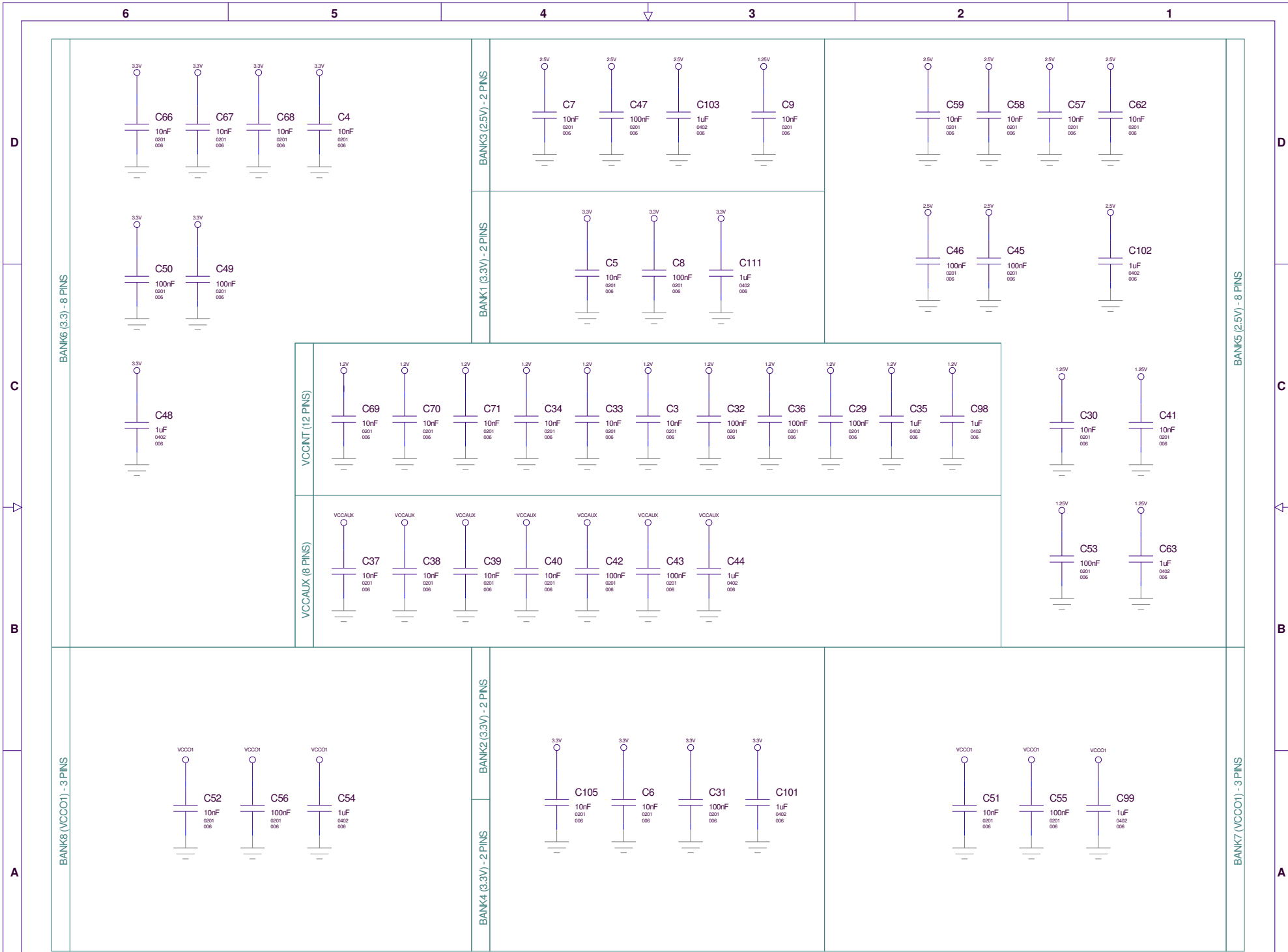

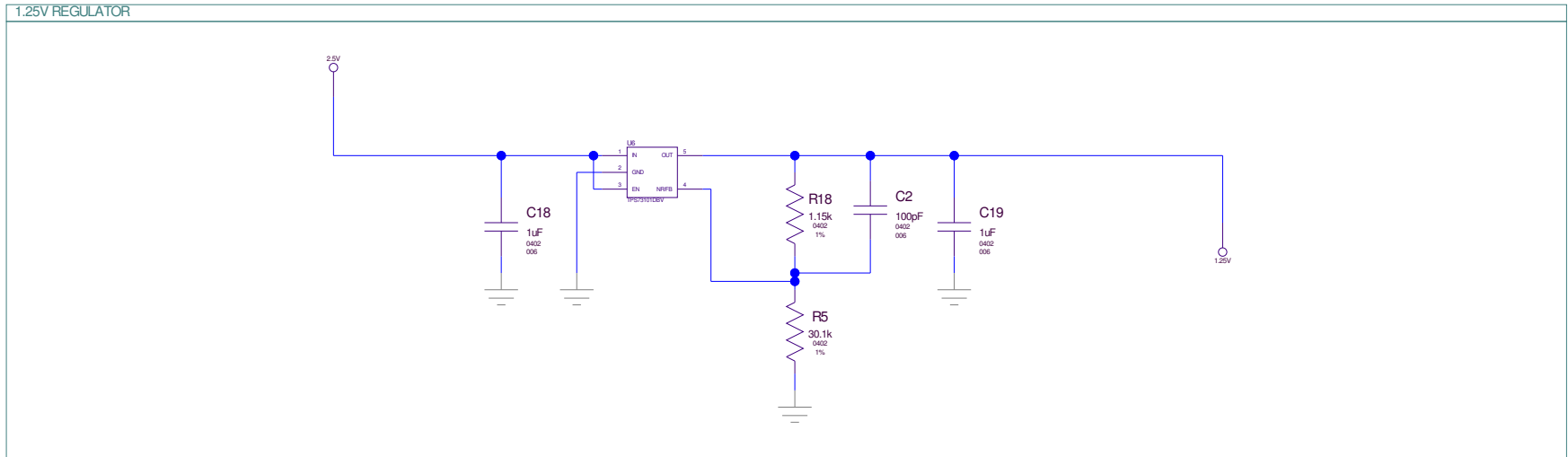
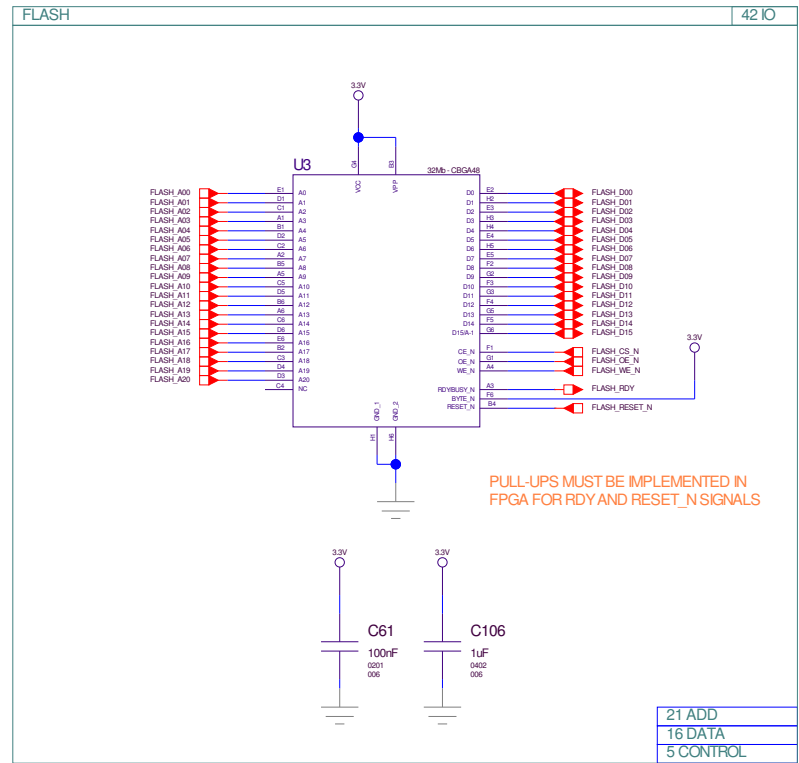
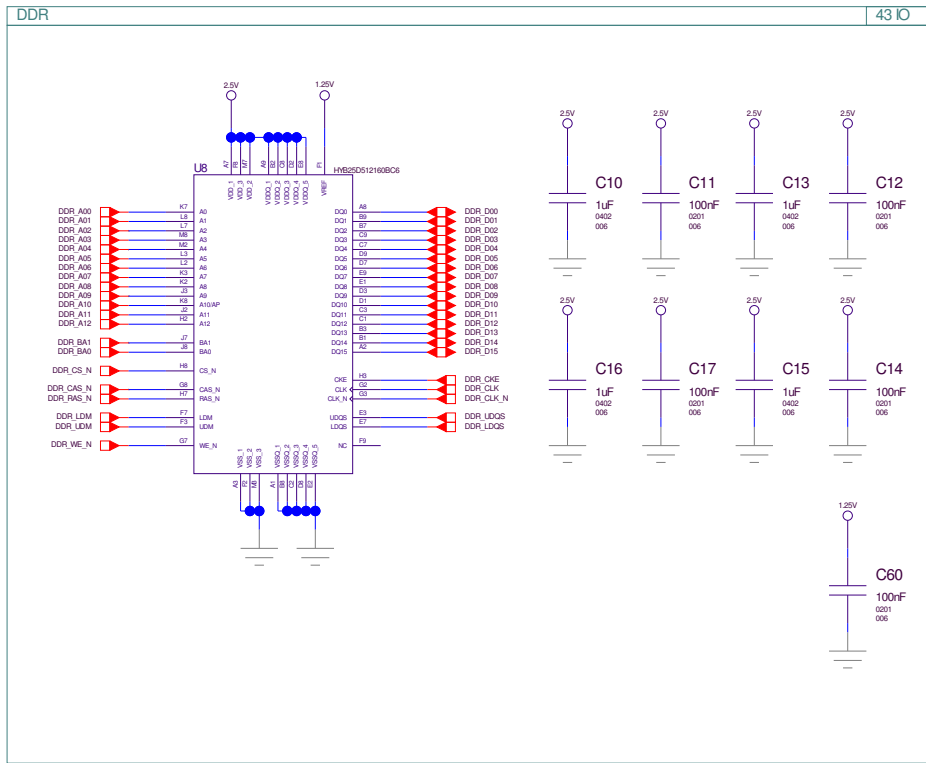

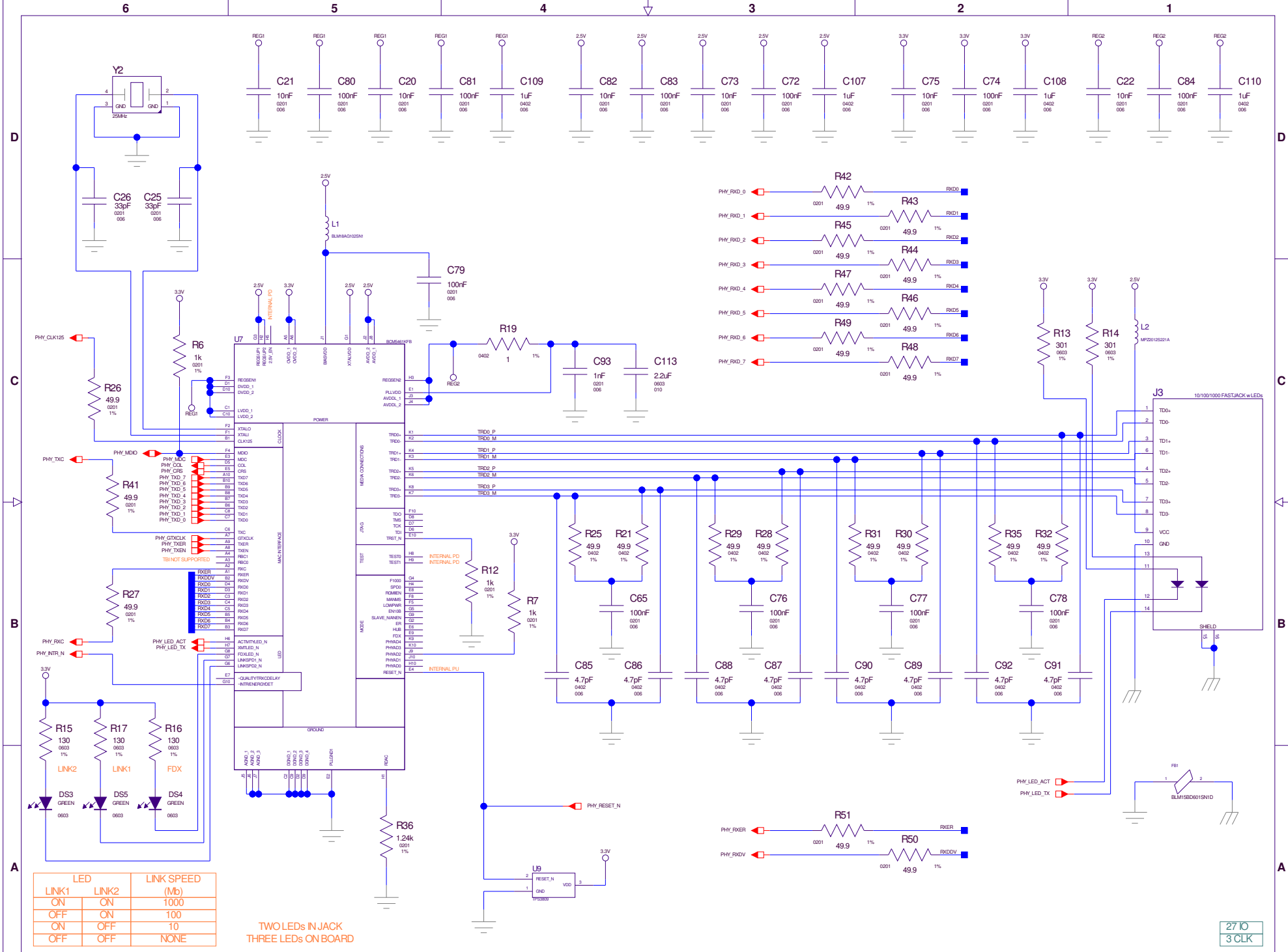

LED		LINK SPEED
LINK1	LINK2	(Mb)
ON	ON	1000
OFF	ON	100
ON	OFF	10
OFF	OFF	NONE

TWO LEDs IN JACK
THREE LEDs ON BOARD

27 IO
3 CLK

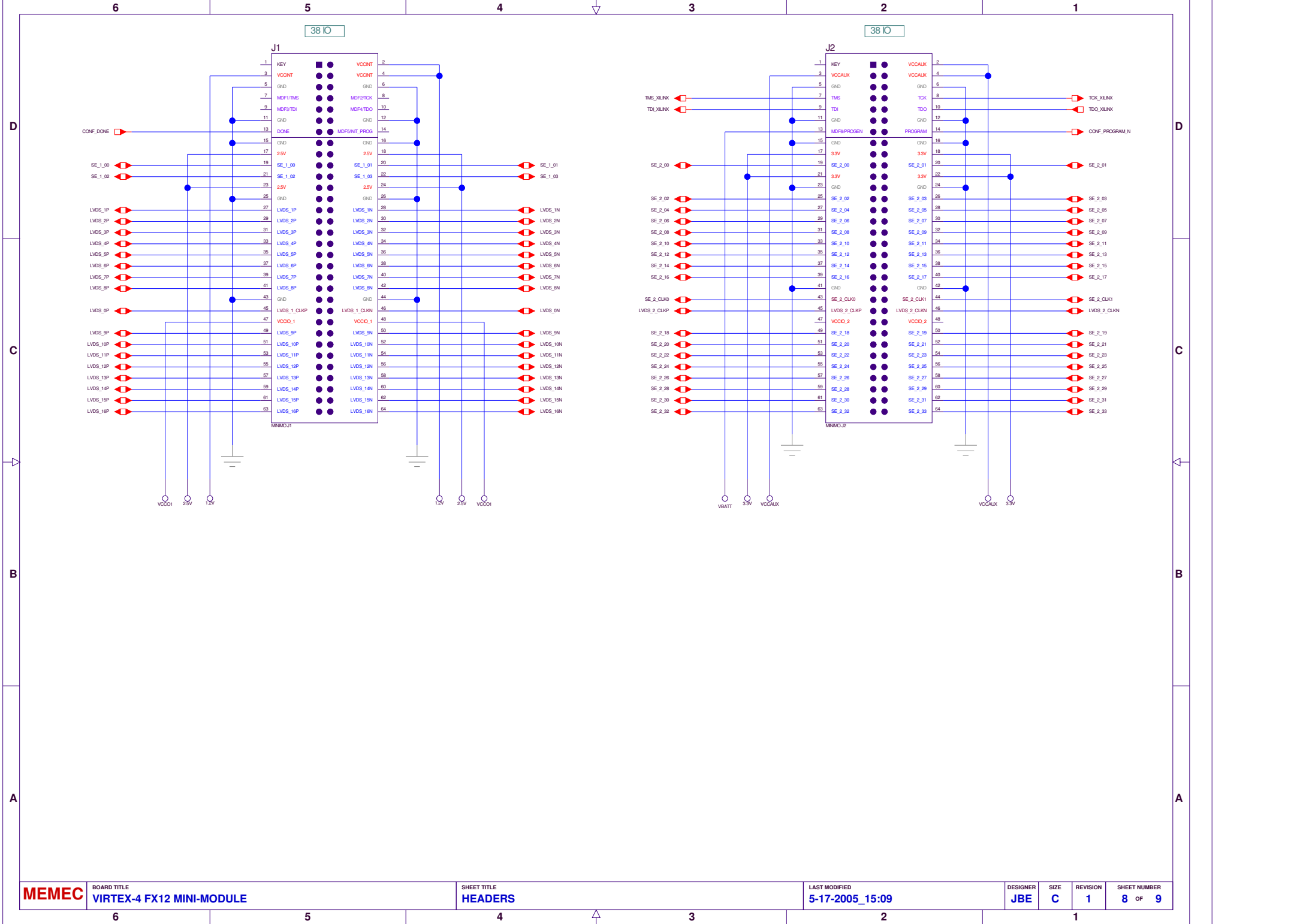

D

D

C

C

B

B

A

A

REVA	REV1
CORRECTED DDR DATA LINE CONNECTIONS	
CORRECTED PHY LED CONNECTIONS	
ADDED VBATT CONNECTION	

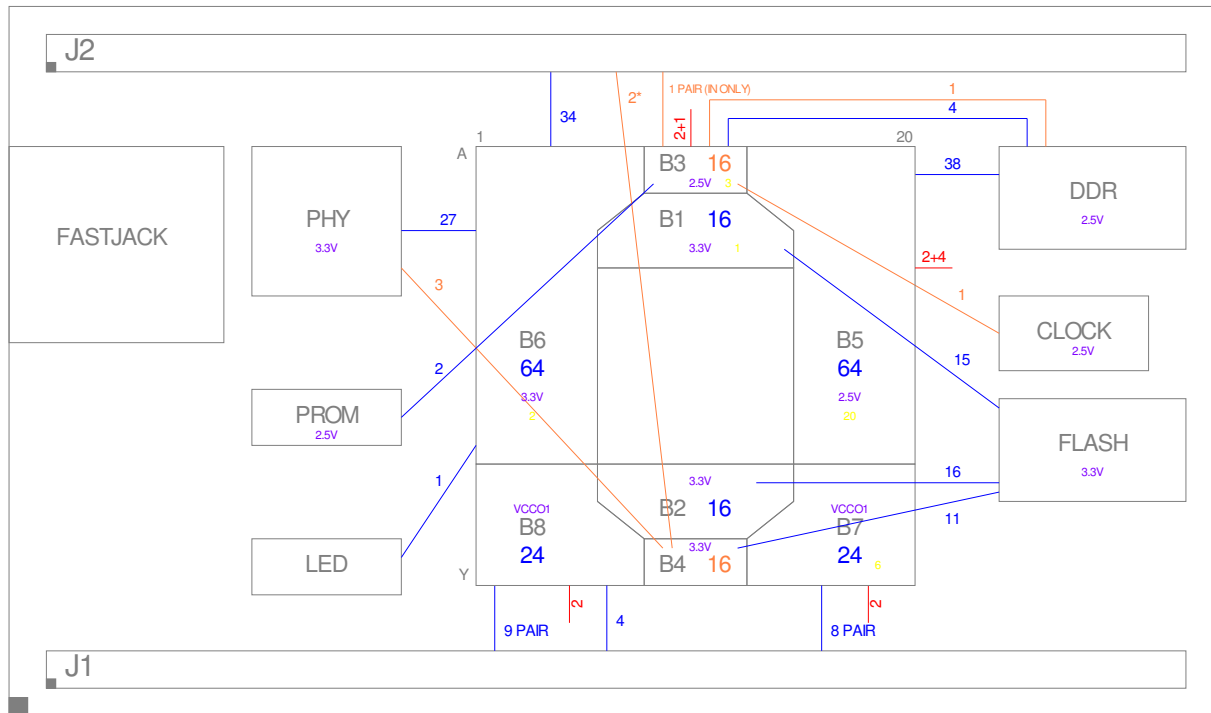

CIRCUIT	IO	CLK	DCI	VREF	TOTAL
J1	36	2	4	0	42
J2	36	2	0	0	38
DDR	42	1	4	5	52
FLASH	42	0	0	0	42
ETHERNET	27	3	0	0	30
PROM	2	0	0	0	2
LED	1	0	0	0	1
CLOCK CAN	0	1	0	0	1
NC	29	3	0	0	32
TOTAL	215	12	8	5	240

BANK	IO
1	16
2	16
3	16
4	16
5	64
6	64
7	24
8	24
TOTAL	240