

TOSHIBA CCD LINEAR IMAGE SENSOR CCD (Charge Coupled Device)

# TCD2557D

The TCD2557D is a high sensitive and low dark current 5340 elements × 3 line CCD color image sensor which includes CCD drive circuit, clamp circuit and sample and hold circuit.

The sensor can be used for image scanner. The device contains a row of 5340 × 3 photodiodes, which provide a 24 lines/mm (600DPI) across a A4 size paper. The device is operated by 5 V (Pulse), and 12 V power supply.

**FEATURES**

- Number of Image Sensing Elements : 5340 elements × 3 line
- Image Sensing Element Size : 7 μm by 7 μm on 7 μm centers
- Photo Sensing Region : High sensitive and low dark current PN photodiode
- Distance Between Photodiode Array : 28 μm, 4 line
- Clock : 2 phase (5 V)
- Power Supply : 12 V Power supply voltage
- Internal Circuit : Sample and Hold Circuit, Clamp Circuit
- Package : 22 pin CERDIP package
- Color Filter : Red, Green, Blue

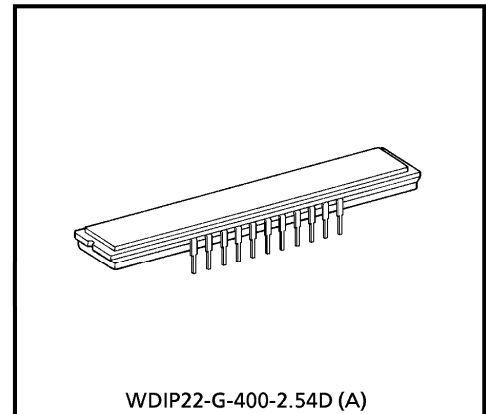

Weight : 5.2 g (Typ.)

**MAXIMUM RATINGS (Note 1)**

CHARACTERISTIC	SYMBOL	RATING	UNIT
Clock Pulse Voltage	$V\phi$	- 0.3~8	V
Shift Pulse Voltage	$V_{SH}$		
Reset Pulse Voltage	$V_{RS}$		
Clamp Pulse Voltage	$V_{CP}$		
Sample and Hold Voltage	$V_{SP}$		
Power Supply	$V_{OD}$	- 0.3~15	V
Operating Temperature	$T_{opr}$	0~60	°C
Storage Temperature	$T_{stg}$	- 25~85	°C

(Note 1) : All voltage are with respect to SS terminals (Ground).

**PIN CONNECTIONS**

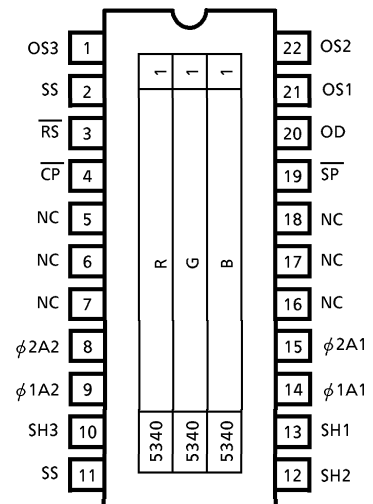

(TOP VIEW)

980910EBA1

- TOSHIBA is continually working to improve the quality and the reliability of its products. Nevertheless, semiconductor devices in general can malfunction or fail due to their inherent electrical sensitivity and vulnerability to physical stress. It is the responsibility of the buyer, when utilizing TOSHIBA products, to observe standards of safety, and to avoid situations in which a malfunction or failure of a TOSHIBA product could cause loss of human life, bodily injury or damage to property. In developing your designs, please ensure that TOSHIBA products are used within specified operating ranges as set forth in the most recent products specifications. Also, please keep in mind the precautions and conditions set forth in the TOSHIBA Semiconductor Reliability Handbook.
- The products described in this document are subject to the foreign exchange and foreign trade laws.
- The information contained herein is presented only as a guide for the applications of our products. No responsibility is assumed by TOSHIBA CORPORATION for any infringements of intellectual property or other rights of the third parties which may result from its use. No license is granted by implication or otherwise under any intellectual property or other rights of TOSHIBA CORPORATION or others.
- The information contained herein is subject to change without notice.

**CIRCUIT DIAGRAM**

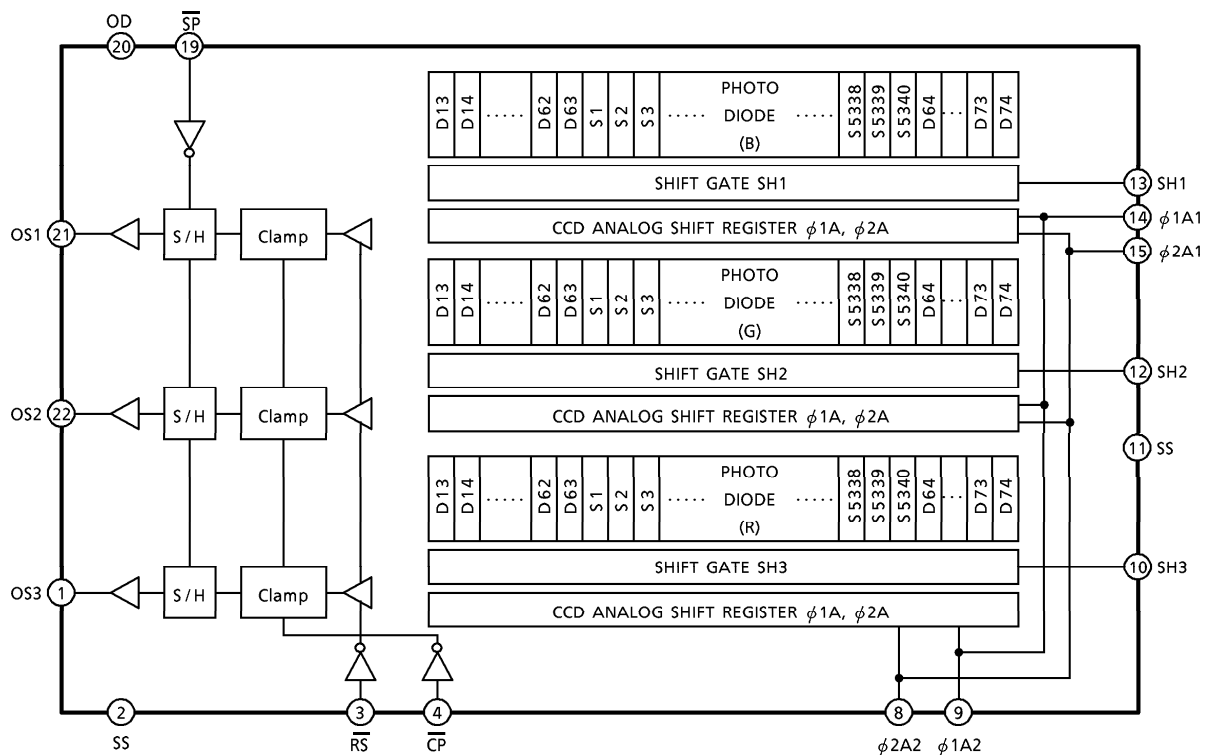

**PIN NAMES**

PIN No.	SYMBOL	NAME	PIN No.	SYMBOL	NAME
1	OS3	Signal Output 3 (Red)	12	SH2	Shift Gate 2
2	SS	Ground	13	SH1	Shift Gate 1
3	$\overline{RS}$	Reset Gate	14	$\phi 1A1$	Clock 1 (Phase 1)
4	$\overline{CP}$	Clamp Gate	15	$\phi 2A1$	Clock 1 (Phase 2)
5	NC	Non Connection	16	NC	Non Connection
6	NC	Non Connection	17	NC	Non Connection
7	NC	Non Connection	18	NC	Non Connection
8	$\phi 2A2$	Clock 2 (Phase 2)	19	$\overline{SP}$	Sample and Hold Gate
9	$\phi 1A2$	Clock 2 (Phase 1)	20	OD	Power
10	SH3	Shift Gate 3	21	OS1	Signal Output 1 (Blue)
11	SS	Ground	22	OS2	Signal Output 2 (Green)

## OPTICAL / ELECTRICAL CHARACTERISTICS

(Ta = 25°C, V<sub>OD</sub> = 12 V, V<sub>φ</sub> = V<sub>SH</sub> = V<sub>RS</sub> = V<sub>CP</sub> = 5 V (PULSE), f<sub>φ</sub> = 1 MHz, f<sub>RS</sub> = 1 MHz, t<sub>INT</sub> = 10 ms, LIGHT SOURCE = A LIGHT SOURCE + CM500S FILTER (t = 1 mm), LOAD RESISTANCE = 100 kΩ)

CHARACTERISTIC	SYMBOL	MIN.	TYP.	MAX.	UNIT	NOTE
Sensitivity	R <sub>R</sub>	6.5	9.3	12.1	V / (lx·s)	(Note 2)
	R <sub>G</sub>	6.9	9.9	12.9		
	R <sub>B</sub>	3.8	5.4	7.0		
Photo Response Non Uniformity	PRNU (1)	—	10	20	%	(Note 3)
	PRNU (3)	—	3	12	mV	(Note 4)
Image Lag	IL	—	1	—	%	(Note 5)
Saturation Output Voltage	V <sub>SAT</sub>	2.0	2.5	—	V	(Note 6)
Saturation Exposure	SE	—	0.23	—	lx·s	(Note 7)
Dark Signal Voltage	V <sub>DRK</sub>	—	0.5	2.0	mV	(Note 8)
Dark Signal Non Uniformity	DSNU	—	2.0	5.0	mV	(Note 8)
DC Power Dissipation	P <sub>D</sub>	—	300	400	mW	
Total Transfer Efficiency	TTE	92	—	—	%	
Output Impedance	Z <sub>O</sub>	—	0.5	1.0	kΩ	
DC Signal Output Voltage	V <sub>OS</sub>	3.5	5.0	7.5	V	(Note 9)
Random Noise	N <sub>Dσ</sub>	—	0.8	—	mV	(Note 10)
Reset Noise	V <sub>RSN</sub>	—	0.5	1.0	V	(Note 9)

(Note 2) : Responsivity is defined for each color of signal outputs average when the photosensitive surface is applied with the light of uniform illumination and uniform color temperature.

(Note 3) : PRNU (1) is defined for each color on a single chip by the expressions below when the photosensitive surface is applied with the light of uniform illumination and uniform color temperature.

$$\text{PRNU (1)} = \frac{\Delta\bar{x}}{\bar{x}} \times 100 (\%)$$

When  $\bar{x}$  is average of total signal output and  $\Delta\bar{x}$  is the maximum deviation from  $\bar{x}$ .  
The amount of incident light is shown below.

$$\text{Red} = 1/2 \cdot \text{SE}$$

$$\text{Green} = 1/2 \cdot \text{SE}$$

$$\text{Blue} = 1/4 \cdot \text{SE}$$

(Note 4) : PRNU (3) is defined as maximum voltage with next pixel, where measured 5% of SE (Typ.).

(Note 5) : Image Lag is defined as follows.

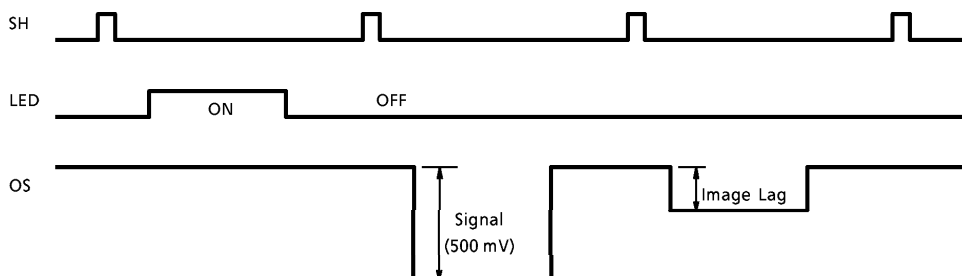

(Note 6) :  $V_{SAT}$  is defined as minimum saturation output of all effective pixels.

(Note 7) : Definition of SE

$$SE = \frac{V_{SAT}}{R_G} (Ix \cdot s)$$

(Note 8) :  $V_{DRK}$  is defined as average dark signal voltage of all effective pixels.  
 $DSNU$  is defined as different voltage between  $V_{DRK}$  and  $V_{MDK}$  when  $V_{MDK}$  is maximum dark signal voltage.



(Note 9) : DC signal output voltage is defined as follows.  
 Reset Noise Voltage is defined as follows.

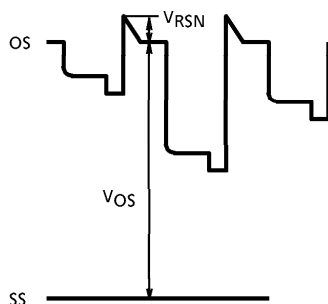

(Note 10) : Random noise is defined as the standard deviation (sigma) of the output level difference between two adjacent effective pixels under no illumination (i.e. dark conditions) calculated by the following procedure.

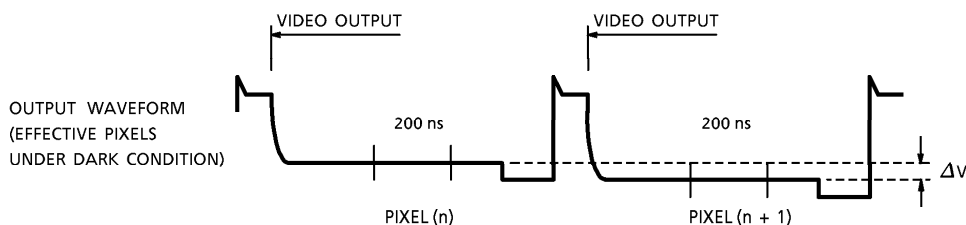

- 1) Two adjacent pixels (pixel n and n + 1) in one reading are fixed as measurement points.
- 2) Each of the output level at video output periods averaged over 200ns period to get V (n) and V (n + 1).
- 3) V (n + 1) is subtracted from V (n) to get ΔV.

$$\Delta V = V(n) - V(n + 1)$$

- 4) The standard deviation of ΔV is calculated after procedure 2) and 3) are repeated 30 times (30 readings).

$$\overline{\Delta V} = \frac{1}{30} \sum_{i=1}^{30} |\Delta V_i| \quad \sigma = \sqrt{\frac{1}{30} \sum_{i=1}^{30} (|\Delta V_i| - \overline{\Delta V})^2}$$

- 5) Procedure 2), 3) and 4) are repeated 10 times to get sigma value.
- 6) 10 sigma values are averaged.

$$\overline{\sigma} = \frac{1}{10} \sum_{j=1}^{10} \sigma_j$$

- 7)  $\overline{\sigma}$  value calculated using the above procedure is observed  $\sqrt{2}$  times larger than that measured relative to the ground level. So we specify random noise as follows.

$$ND \sigma = \frac{1}{\sqrt{2}} \overline{\sigma}$$

## OPERATING CONDITION

CHARACTERISTIC		SYMBOL	MIN.	TYP.	MAX.	UNIT	NOTE
Clock Pulse Voltage	"H" Level	$V_{\phi A}$	4.5	5.0	5.5	V	
	"L" Level		0.0	—	0.3		
Shift Pulse Voltage	"H" Level	$V_{SH}$	$V_{\phi A} \text{"H"} - 0.5$	$V_{\phi A} \text{"H"}$	$V_{\phi A} \text{"H"}$	V	(Note 11)
	"L" Level		0.0	—	0.5		
Reset Pulse Voltage	"H" Level	$V_{\overline{RS}}$	4.5	5.0	5.5	V	
	"L" Level		0.0	—	0.5		
Sample and Hold Pulse Voltage	"H" Level	$V_{\overline{SP}}$	4.5	5.0	5.5	V	(Note 12)
	"L" Level		0.0	—	0.5		
Clamp Pulse Voltage	"H" Level	$V_{\overline{CP}}$	4.5	5.0	5.5	V	
	"L" Level		0.0	—	0.5		
Power Supply Voltage		$V_{OD}$	11.4	12.0	13.0	V	

(Note 11) :  $V_{\phi A} \text{"H"}$  means the high level voltage of  $V_{\phi A}$  when SH pulse is high level.

(Note 12) : Supply "L" Level to  $\overline{SP}$  terminal when sample and hold circuitry is not used.

## CLOCK CHARACTERISTICS (Ta = 25°C)

CHARACTERISTIC	SYMBOL	MIN.	TYP.	MAX.	UNIT
Clock Pulse Frequency	$f_{\phi}$	0.3	1.0	6.0	MHz
Reset Pulse Frequency	$f_{\overline{RS}}$	0.3	1.0	6.0	MHz
Clamp Pulse Frequency (Bit clamp mode)	$f_{\overline{CP}}$	0.3	1.0	6.0	MHz
Clamp Pulse Frequency (Line clamp mode)	$f_{\overline{CP}}$	10	100	—	Hz
Sample and Hold Pulse Frequency	$f_{\overline{SP}}$	0.3	1.0	6.0	MHz
Clock 1 Capacitance	$C_{\phi 1}$	—	250	400	pF
Clock 2 Capacitance	$C_{\phi 2}$	—	230	400	pF
Shift Gate Capacitance	$C_{SH}$	—	20	100	pF
Reset Gate Capacitance	$C_{\overline{RS}}$	—	10	30	pF
Sample and Hold Gate Capacitance	$C_{\overline{SP}}$	—	10	30	pF
Clamp Gate Capacitance	$C_{CP}$	—	10	30	pF

TIMING CHART (BIT CLAMP MODE)

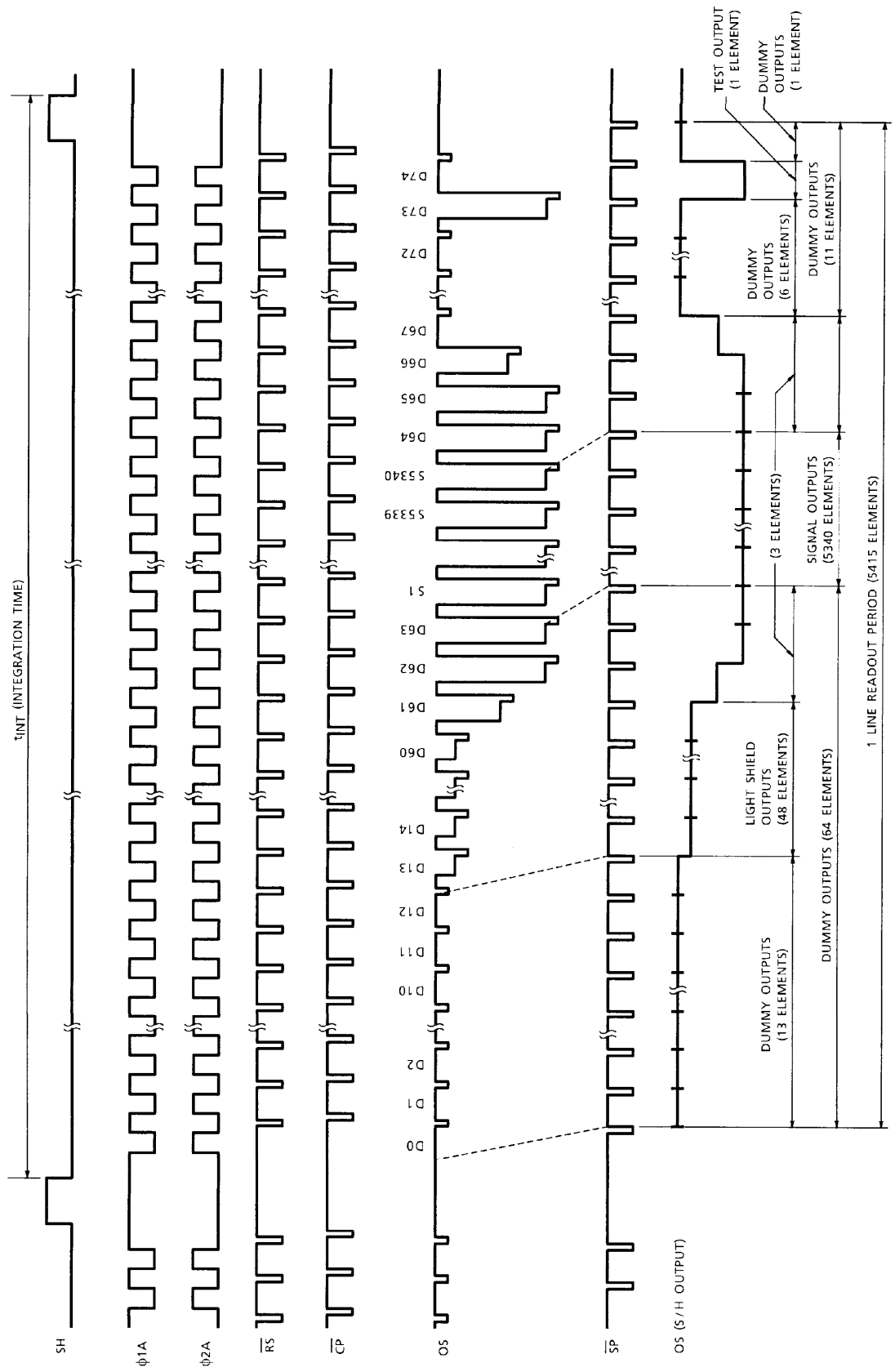

TIMING CHART (LINE CLAMP MODE)

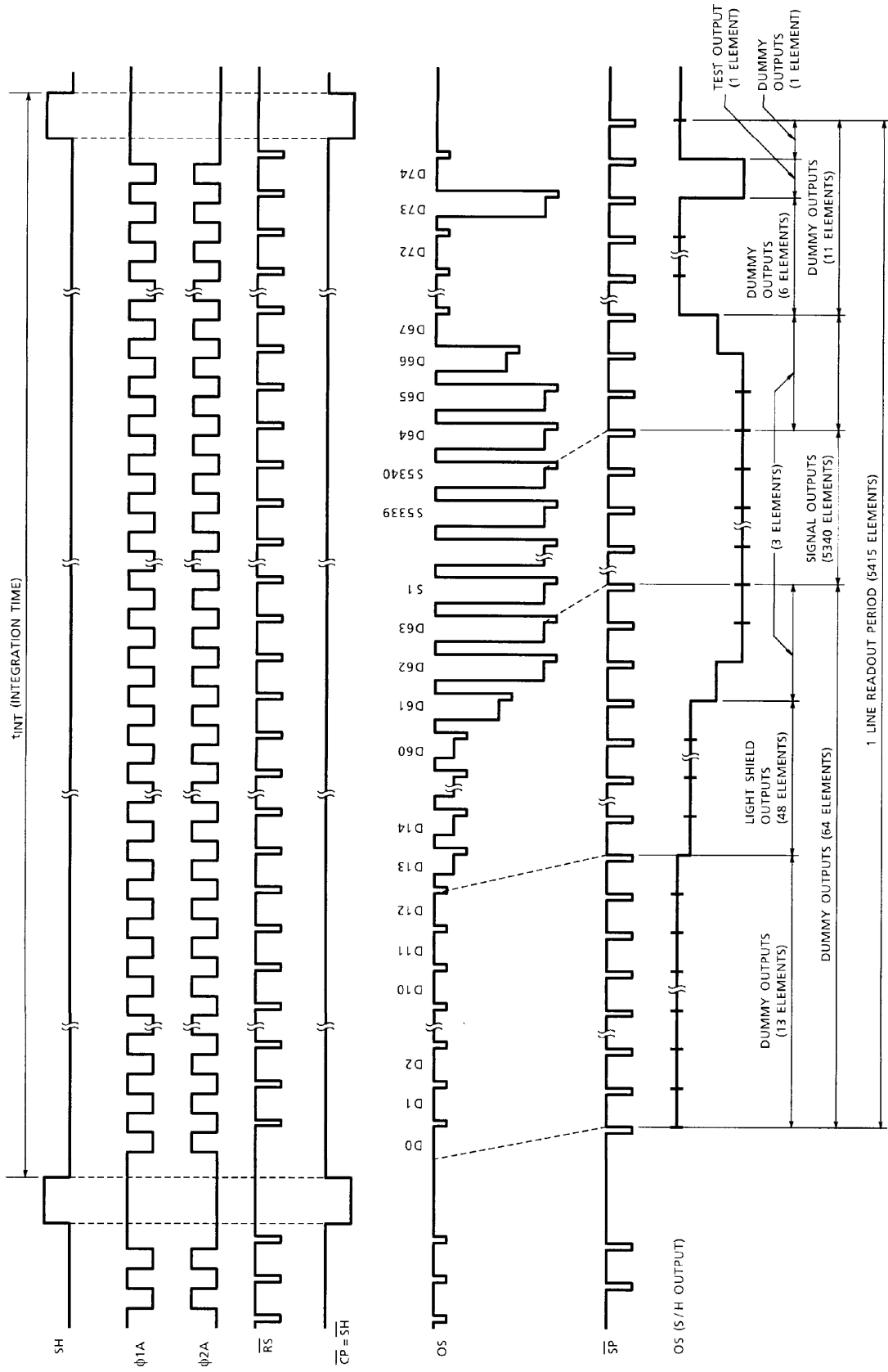



**TIMING REQUIREMENTS**

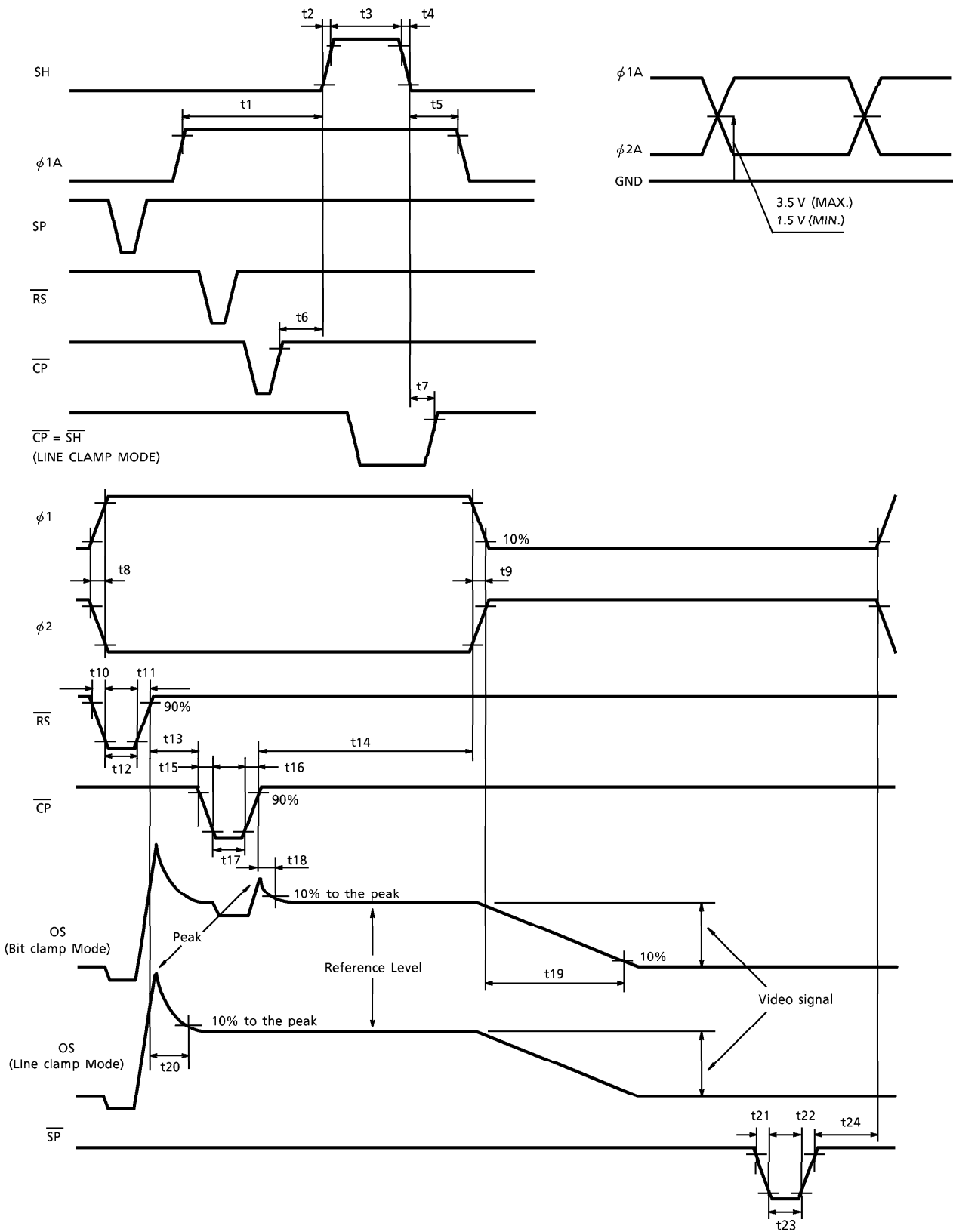

**TIMING REQUIREMENTS**

CHARACTERISTIC	SYMBOL	MIN.	TYP. (Note 13)	MAX.	UNIT
Pulse Timing of SH and $\phi 1$	t1	120	1000	—	ns
	t5	800	1000	—	
SH Pulse Rise Time, Fall Time	t2, t4	0	50	—	ns
SH Pulse Width	t3	3000	5000	—	ns
Pulse Timing of SH and $\overline{CP}$	t6	200	500	—	ns
Pulse Timing of SH and $\overline{CP}$ (Line clamp mode)	t7	10	100	—	ns
$\phi 1, \phi 2$ Pulse Rise Time, Fall Time	t8, t9	0	50	—	ns
RS Pulse Rise Time, Fall Time	t10, t11	0	20	—	ns
$\overline{RS}$ Pulse Width	t12	30	80	—	ns
Pulse Timing of $\overline{RS}$ and $\overline{CP}$	t13	10	20	—	ns
Pulse Timing of $\phi 1A, \phi 2A$ and $\overline{CP}$	t14	0	20	—	ns
$\overline{CP}$ Pulse Rise Time, Fall Time	t15, t16	0	20	—	ns
$\overline{CP}$ Pulse Width (Note 14)	t17	40 (3000)	80 (5000)	—	ns
Reference Level Settle Time (Bit clamp mode)	t18	—	35	45 (Note 17)	ns
Video Data Delay Time (Note 15)	t19	—	40	60 (Note 16)	ns
Reference Level Settle Time (Line clamp mode)	t20	—	60	70 (Note 17)	ns
$\overline{SP}$ Pulse Rise Time, Fall Time	t21, t22	0	20	—	ns
$\overline{SP}$ Pulse Width	t23	45	100	—	ns
Pulse Timing of $\phi A$ and $\overline{SP}$	t24	0	20	—	ns

(Note 13) : TYP. is the case of  $f_{RS} = 1.0$  MHz

(Note 14) : Line clamp Mode inside ( ).

(Note 15) : Load resistance is 100 k $\Omega$

(Note 16) : Typical settle time to about 1% of final value

(Note 17) : Typical settle time to about 1% of the peak

**APPLICATION NOTE**  
**MODE SELECT**

Sample and Hold	ON $\overline{SP}$ Pulse	OFF $\overline{SP} = \text{Low}$
Clamp Mode	Bit Clamp $\overline{CP}$ Pulse	Line Clamp $\overline{CP} = \overline{SH}$



**CAUTION****1. Window Glass**

The dust and stain on the glass window of the package degrade optical performance of CCD sensor.

Keep the glass window clean by saturating a cotton swab in alcohol and lightly wiping the surface, and allow the glass to dry, by blowing with filtered dry N<sub>2</sub>.

Care should be taken to avoid mechanical or thermal shock because the glass window is easily to damage.

**2. Electrostatic Breakdown**

Store in shorting clip or in conductive foam to avoid electrostatic breakdown.

This device has some weakly terminals for static electricity. Therefore, please pay attention to treat this device.

CCD Image Sensor is protected against static electricity, but inferior puncture mode device due to static electricity is sometimes detected. In handling the device, it is necessary to execute the following static electricity preventive measures, in order to prevent the trouble rate increase of the manufacturing system due to static electricity.

- a. Prevent the generation of static electricity due to friction by making the work with bare hands or by putting on cotton gloves and non-charging working clothes.
- b. Discharge the static electricity by providing earth plate or earth wire on the floor, door or stand of the work room.
- c. Ground the tools such as soldering iron, radio cutting pliers or pincer.  
It is not necessarily required to execute all precaution items for static electricity.  
It is all right to mitigate the precautions by confirming that the trouble rate within the prescribed range.

**3. Incident Light**

CCD sensor is sensitive to infrared light.

Note that infrared light component degrades resolution and PRNU of CCD sensor.

**4. Lead Frame Forming**

Since this package is not strong against mechanical stress, you should not reform the lead frame.

We recommend to use a IC-inserter when you assemble to PCB.

**OUTLINE DRAWING**  
WDIP22-G-400-2.54D (A)

Unit : mm

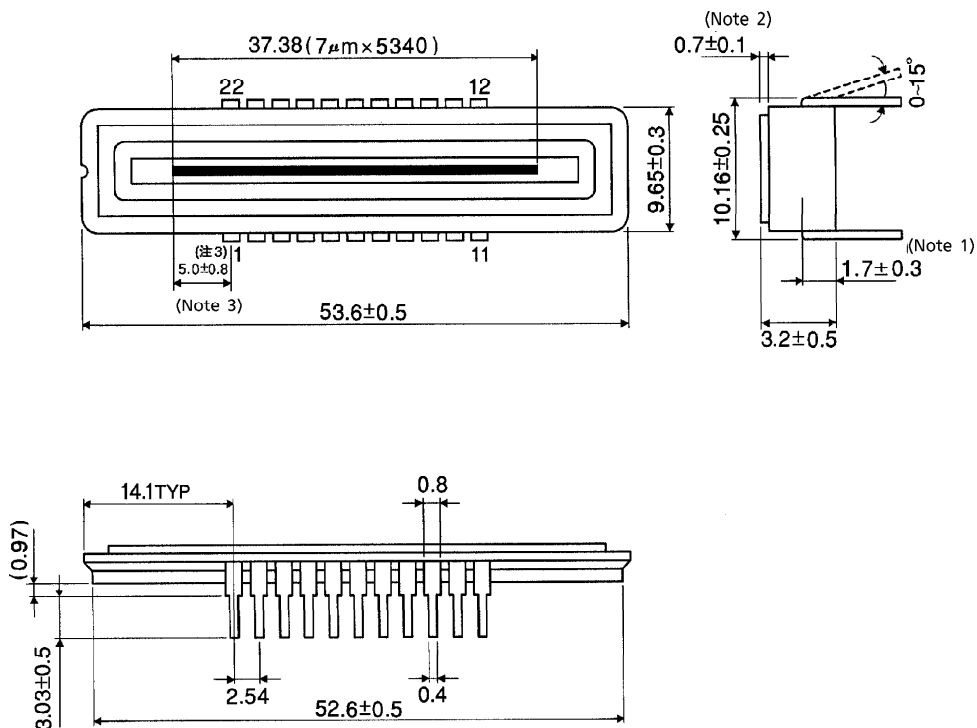

(Note 1) : TOP OF CHIP TO BOTTOM OF PACKAGE.

(Note 2) : GLASS THICKNESS (n = 1.5)

(Note 3) : No.1 SENSOR ELEMENT (S1) TO EDGE OF No.1 PIN.

Weight : 5.2 g (Typ.)