

INNOLUX DISPLAY CORPORATION

LCD MODULE

SPECIFICATION

Customer: _____
Model Name: AT070TN83
SPEC NO.: A070-83-TT-01
Date: 2006/11/03
Version: 01



Preliminary Specification

Final Specification

Option
<input checked="" type="checkbox"/> AT070TN83 LCM (TTL T-con)
<input checked="" type="checkbox"/> Touch Screen Panel

For Customer's Acceptance

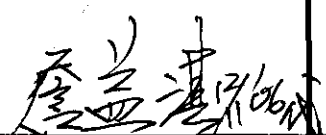
Approved by	Comment

Approved by	Reviewed by	Prepared by
	 12/1/06	陳格文 11/29/06

Record of Revision

Version	Revise Date	Page	Content
Prep Spec. 01	2006/07/26		Initial release.
02	2006/08/02		Modify the model name from AT070TN08 V.4 to AT070TN83
		5	Modify the power voltage and input signal voltage in absolute maximum rating
03	2006/09/01	21	Modify the mechanical drawing
Final Spec. 01	2006/11/03	1	Add Backlight power consumption, Panel power consumption, Weight.
		3	Add LED reverse voltage & forward current
		7	Modify LED voltage & current to LED forward voltage & current
		7	Add values of current for driver.
		8	Add BL to power sequence
		25	Add Package drawing.

Contents

1. General Specifications	1
2. Pin Assignment	2
2.1. TFT LCD Panel Driving Section	2
2.2. Backlight Unit Section	4
3. Operation Specifications	5
3.1. Absolute Maximum Rating	5
3.1.1. Typical Operation Conditions	6
3.1.2. Backlight Driving Conditions	7
3.2. Power Sequence	8
3.3. Timing Characteristics	9
3.3.1. Timing Conditions	9
3.3.2. Timing Diagram	11
4. Touch Screen Panel Specifications	13
4.1. Electrical Characteristics	13
4.2. Mechanical & Reliability Characteristics	13
4.3. Touch Screen Panel Block	14
4.4. Touch Screen Panel Pin Definition	15
5. Optical Specifications	16
6. Reliability Test	20
6.1. Environmental Characteristics	20
6.2 Reliability Test Items	20
7. General Precautions	22
7.1. Safety	22
7.2. Handling	22
7.3. Static Electricity	22
7.4. Storage	22
7.5. Cleaning	22
8. Mechanical Drawing	23
9. Package Drawing	24
9.1. Packaging Material Table	24
9.2. Packaging Quantity	24
9.3. Packaging Drawing	25

1. General Specifications

No.	Item	Specification	Remark
1	LCD size	7.0 inch(Diagonal)	
2	Driver element	a-Si TFT active matrix	
3	Resolution	800X3(RGB)X480	
4	Display mode	Normally white, Transmissive	
5	Dot pitch	0.0635(W)X0.1905(H) mm	
6	Active area	152.4 (W)X91.44 (H) mm	
7	Module size	165(W)X104(H)X6.5(D) mm	Note 1
8	Surface treatment	Anti-Glare	
9	Color arrangement	RGB-stripe	
10	Interface	Digital(TTL)	
11	Backlight power consumption	1.728W (Typ.)	
12	Panel power consumption	0.990W (Typ.)	
13	Weight	160g (Typ.)	

Note 1: Refer to Mechanical Drawing.

2. Pin Assignment

2.1. TFT LCD Panel Driving Section

1. TTL Connector is used for the module electronics interface. The recommended model is FH19-40S-0.5SH manufactured by Hirose.

Pin No.	Symbol	I/O	Function	Remark
1	GND	P	Power ground	
2	GND	P	Power ground	
3	NC	-	No Connection	
4	VCC	I	Power supply for digital circuit	
5	VCC	I	Power supply for digital circuit	
6	VCC	I	Power supply for digital circuit	
7	VCC	I	Power supply for digital circuit	
8	NC	-	No Connection	
9	DE	I	Data enable	
10	GND	P	Power ground	
11	GND	P	Power ground	
12	GND	P	Power ground	
13	B5	I	Blue data input (MSB)	
14	B4	I	Blue data input	
15	B3	I	Blue data input	
16	GND	P	Power ground	
17	B2	I	Blue data input	
18	B1	I	Blue data input	
19	B0	I	Blue data input(LSB)	

20	GND	P	Power ground	
21	G5	I	Green data input(MSB)	
22	G4	I	Green data input	
23	G3	I	Green data input	
24	GND	P	Power ground	
25	G2	I	Green data input	
26	G1	I	Green data input	
27	G0	I	Green data input(LSB)	
28	GND	P	Power ground	
29	R5	I	Red data input(MSB)	
30	R4	I	Red data input	
31	R3	I	Red data input	
32	GND	P	Power ground	
33	R2	I	Red data input	
34	R1	I	Red data input	
35	R0	I	Red data input(LSB)	
36	GND	P	Power ground	
37	GND	P	Power ground	
38	DCLK	I	Sample clock	
39	GND	P	Power ground	
40	GND	P	Power ground	

I: input, O: output, P: Power

2.2. Backlight Unit Section

2. LED Light Bar Connector is used for the integral backlight system. The recommended model is BHSR-02VS-1 manufactured by JST.

Pin No.	Symbol	I/O	Function	Remark
1	VLED+	P	Power supply for backlight unit(High voltage)	Pink
2	VLED-	P	Ground for backlight unit	White

INNOLUX
Confidential

3. Operation Specifications

3.1. Absolute Maximum Rating

(GND=AV_{SS}=0V, Note 2)

Item	Symbol	Values		Unit	Remark
		Min.	Max.		
Power voltage	V _{CC}	-0.3	6.0	V	
Input signal voltage	V _i	-0.3	6.3	V	Note 1
Operation Temperature	T _{OP}	-20	70	°C	
Storage Temperature	T _{ST}	-30	80	°C	
LED Reverse Voltage	V _r	-	1.2	V	each LED
LED Forward Current	I _F	-	25	mA	each LED

Note 1: DCLK, DE, R0~ R5, G0~ G5, B0~ B5.

Note 2: The absolute maximum rating values of this product are not allowed to be exceeded at any times. Should a module be used with any of the absolute maximum ratings exceeded, the characteristics of the module may not be recovered, or in an extreme case, the module may be permanently destroyed.

Note 3: V_r Conditions: Zener Diode 20mA

3.1.1. Typical Operation Conditions

(GND=AV_{SS}=0V)

Item	Symbol	Values			Unit	Remark
		Min.	Typ.	Max.		
Power voltage	V _{CC}	3.0	3.3	3.6	V	Note 1
Current Consumption	I _{CC}	-	300	350	mA	
Input logic high voltage	V _{IH}	0.7V _{CC}	-	V _{CC}	V	Note 2
Input logic low voltage	V _{IL}	0	-	0.3V _{CC}	V	

Note 1: V_{CC} setting should match the signals output voltage (refer to Note 2) of customer's system board .

Note 2: DCLK,DE,R0~ R5,,G0~ G5,B0~ B5.

3.1.2. Backlight Driving Conditions

Item	Symbol	Values			Unit	Remark
		Min.	Typ.	Max.		
LED forward voltage	V_L	9.3	9.9	10.5	V	Note2, 3
LED forward current	I_L	18	20	22	mA	Note 3
LED life time	-	20,000	-	-	Hr	Note 1

Note 1: The “LED life time” is defined as the module brightness decrease to 50% original brightness at $T_a=25^{\circ}\text{C}$ and $I_L =20\text{mA}$. The LED lifetime could be decreased if operating I_L is larger than 20 mA.

Note 2: The LED Supply Voltage is defined by the number of LED at $T_a=25^{\circ}\text{C}$ and $I_L =20\text{mA}$. In the case of 3pcs LED, $V_L=3.3*3=9.9\text{V}$

Note 3: The LED driving condition is defined for each LED module(3 LED Serial).

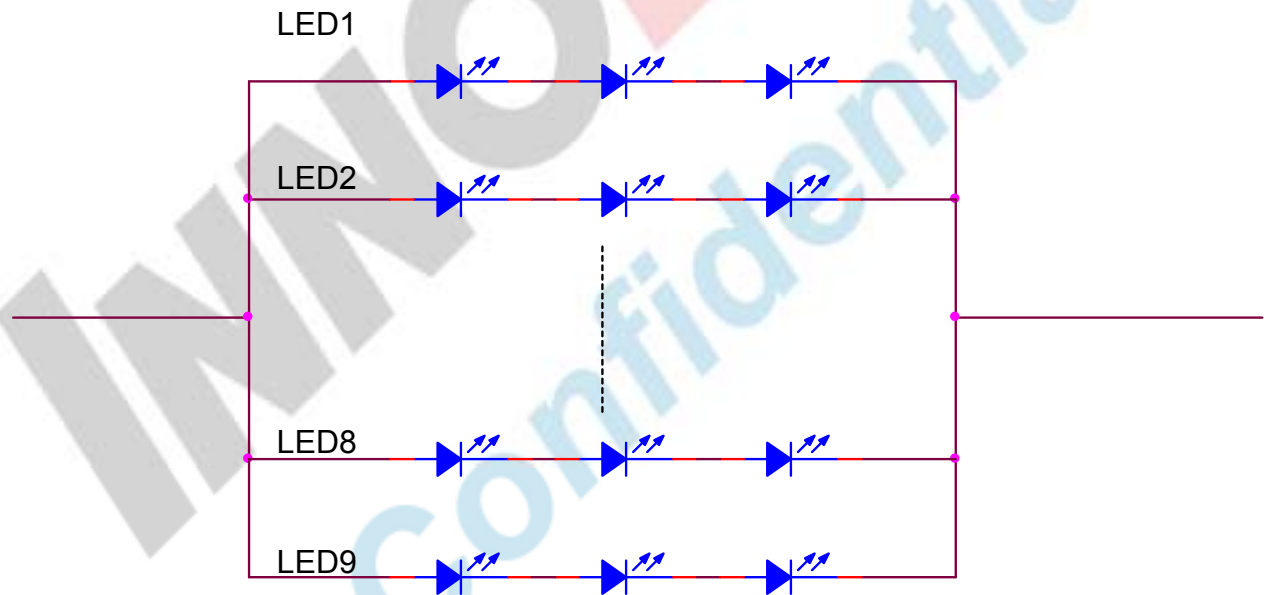

3.2. Power Sequence

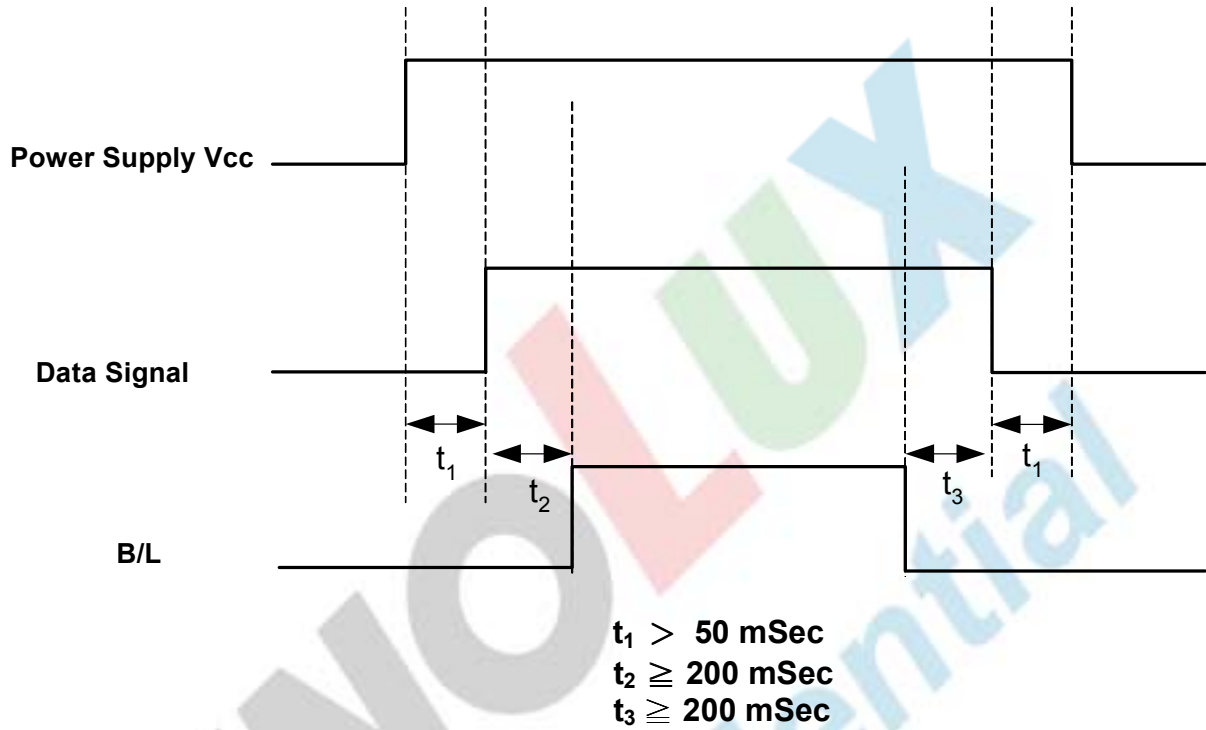

3.3. Timing Characteristics

3.3.1. Timing Conditions

SYNC mode Input signal characteristics (800 x 480)

Item	Symbol	Values			Unit	Remark
		Min.	Typ.	Max.		
Clock Period	t _{CLK}	20.0	30.0	-	ns	
Clock Frequency	f _{CLK}	-	33.3	50	MHz	
Clock Low Level Width	t _{WCL}	8	-	-	ns	
Clock High Level Width	t _{WCH}	8	-	-		
Clock Rise/Fall Time	t _{CLKr} , t _{CLKf}	-	-	3		
HSYNC Period	t _{HP}	-	928	-	t _{CLK}	
HSYNC Pulse Width	t _{HW}	-	48	-	t _{CLK}	
HSYNC Back Porch	t _{HBP}	-	40	-	t _{CLK}	
HSYNC Width + Back Porch	t _{HW} + t _{HBP}	88			t _{CLK}	
Horizontal valid data width	t _{HV}	800			t _{CLK}	
HSYNC Front Porch	t _{HFP}	t _{HP} - t _{HW} - t _{HBP} - t _{HV}			t _{CLK}	
Horizontal Blank	t _{HBK}	t _{HP} - t _{HV}			t _{CLK}	
VSYNC Period	t _{VP}	-	525	-	t _{HP}	
VSYNC Pulse Width	t _{VW}	-	3	-	t _{HP}	
VSYNC Back Porch	t _{VBP}	29			t _{HP}	
Vertical valid data width	t _V	480			t _{HP}	
Vertical Front Porch	t _{VFP}	t _{VP} - t _{VW} - t _{VBP} - t _V			t _{HP}	
Vertical Blank	t _{VBK}	t _{VP} - t _V			t _{HP}	
Data Setup Time	t _{DS}	5	-	-	ns	
Data Hold Time	t _{DH}	10	-	-	ns	

DE mode Input signal characteristics (800 x 480)

Item	Symbol	Values			Unit	Remark
		Min.	Typ.	Max.		
DCLK	Period	t _{CLK}	20.0	30.0	-	ns
	Frequency	f _{CLK}	-	33.3	50	MHz
	Low Level Width	t _{WCL}	6	-	-	ns
	High Level Width	t _{WCH}	6	-	-	
	Rise/Fall Time	t _{CLKr} , t _{CLKf}	-	-	3	
	Duty	-	0.45	0.50	0.55	-
DE	Setup Time	t _{DES}	5	-	-	ns
	Hold Time	t _{DEH}	10	-	-	
	Rise/Fall Time	t _{DEr} , t _{DEf}	-	-	16	
	Horizontal Period	t _{HP}	-	928	-	t _{CLK}
	Horizontal Valid	t _{HV}	800			
	Horizontal Blank	t _{HBK}	t _{HP} - t _{HV}			
	Vertical Period	t _{VP}	-	525	-	t _{HP}
	Vertical Valid	t _w	480			
	Vertical Blank	t _{VBK}	t _{VP} - t _w			
DATA	Setup Time	t _{DS}	5	-	-	ns
	Hold Time	t _{DH}	10	-	-	
	Rise/Fall Time	t _{Dr} , t _{Df}	-	-	3	

3.3.2. Timing Diagram

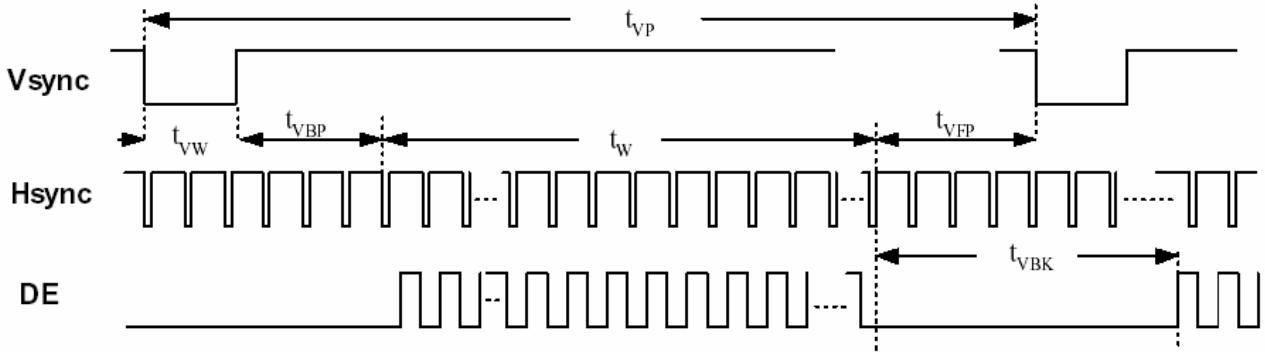

Input Vertical Timing

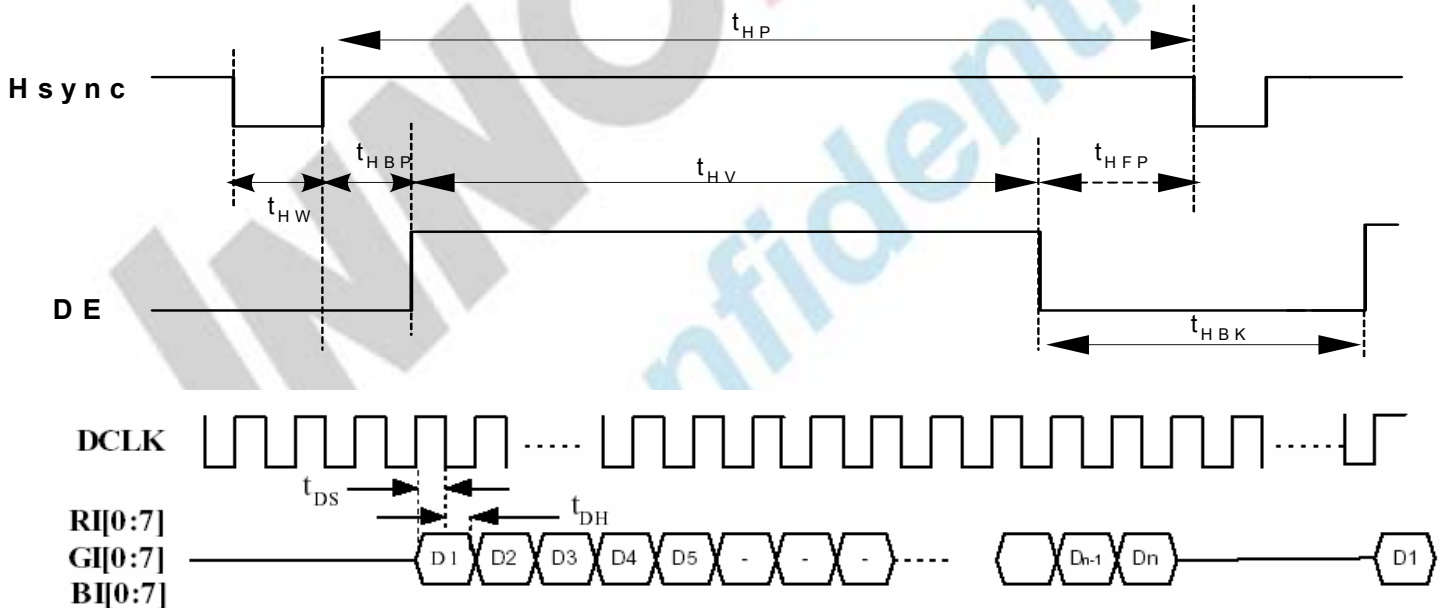

Input Horizontal Timing

版權屬於群創所有，禁止任何未經授權的使用

The copyright belongs to InnoLux. Any unauthorized use is prohibited.

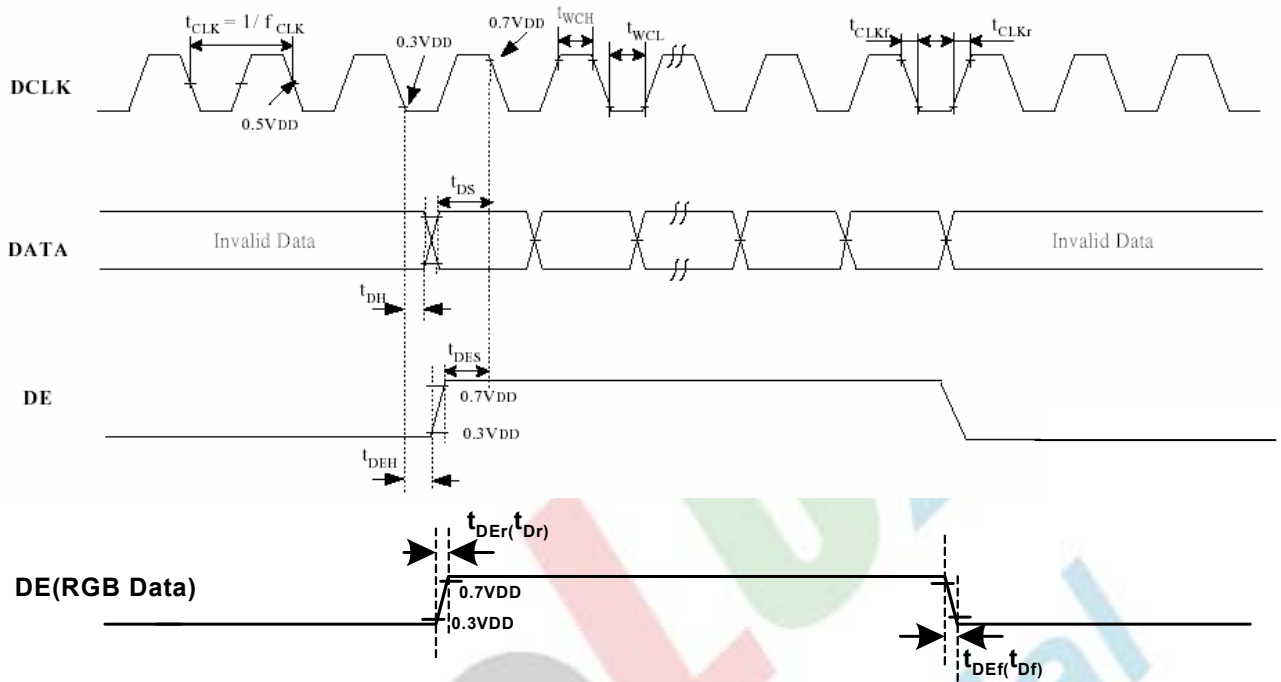

DE and RGB Input Timing

4. Touch Screen Panel Specifications

4.1. Electrical Characteristics

Item	Value			Unit	Remark
	Min.	Typ.	Max.		
Linearity	-1.5	-	1.5	%	Analog X and Y directions
Terminal Resistance	350	-	1200	Ω	X(Film side)
	100	-	600	Ω	Y(Glass side)
Insulation resistance	25	-	-	MΩ	DC 25V
Voltage	-	-	7	V	DC
Chattering	-	-	10	ms	100kΩ pull-up
Transparency	80	-	-	%	

Note: Do not operate it with a thing except a polyacetal pen (tip R0.8mm or less) or a finger, especially those with hard or sharp tips such as a ball point pen or a mechanical pencil.

4.2. Mechanical & Reliability Characteristics

Item	Value			Unit	Remark
	Min.	Typ.	Max.		
Activation force	80	-	-	g	Note 1
Durability-surface scratching	Write 100,000	-	-	characters	Note 2
Durability-surface pitting	1,000,000	-	-	touches	Note 3
Surface hardness	3	-	-	H	

Note 1: Activation force test condition

(1) Input DC 5V on X direction, Drop off Polyacetal Stylus (R0.8), until output voltage stabilize ,then get the activation force ◦

(2) R8.0mm Silicon rubber for finger Activation force test

(3) Test point: 9 points

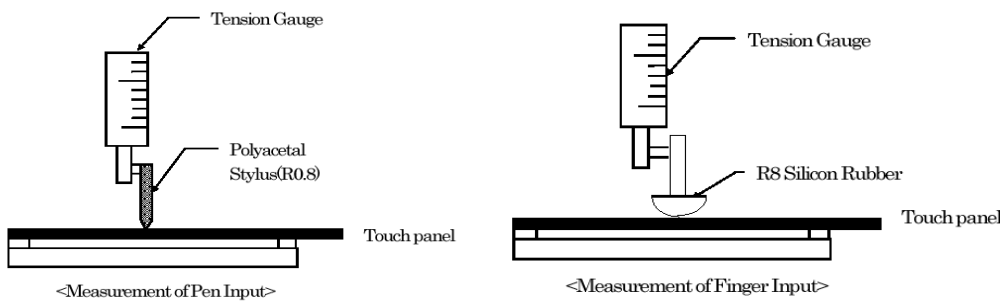

Note 2: Measurement for surface area.

- Scratch 100,000 times straight line on the film with a stylus change every 20,000 times.
- Force: 250gf.
- Speed: 60mm/sec.
- Stylus: R0.8 polyacetal tip.

Note 3: Pit 1,000,000 times on the film with a R0.8 silicon rubber.

- Force: 250gf.
- Speed: 2times/sec.

4.3. Touch Screen Panel Block

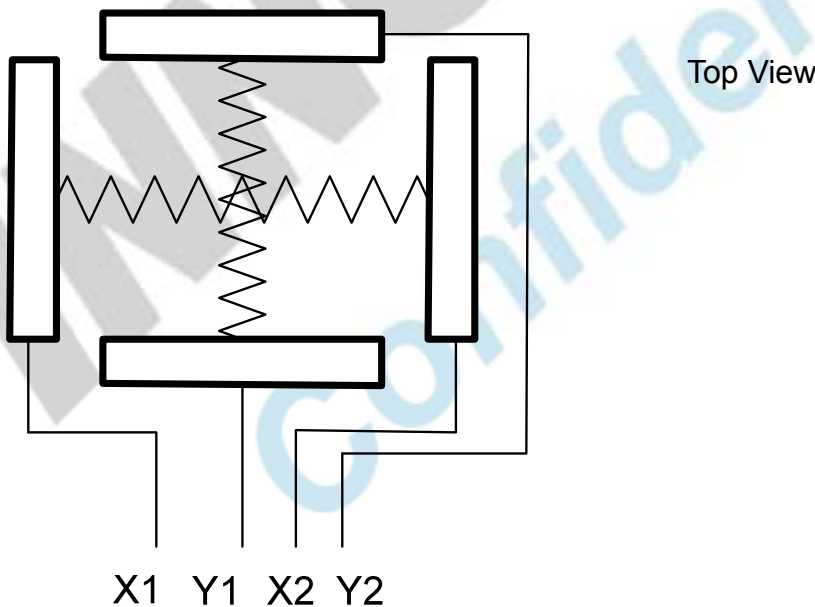

4.4. Touch Screen Panel Pin Definition

Pin No.	Symbol	I/O	Function	Remark
1	Y2	Top	Top electrode – differential analog	
2	X2	Right	Right electrode – differential analog	
3	Y1	Bottom	Bottom electrode – differential analog	
4	X1	Left	Left electrode – differential analog	

INNOLUX
 Confidential

5. Optical Specifications

Item	Symbol	Condition	Values			Unit	Remark
			Min.	Typ.	Max.		
Viewing angle (CR≥ 10)	θ_L	$\Phi=180^\circ$ (9 o'clock)	60	70	-	degree	Note 1
	θ_R	$\Phi=0^\circ$ (3 o'clock)	60	70	-		
	θ_T	$\Phi=90^\circ$ (12 o'clock)	40	50	-		
	θ_B	$\Phi=270^\circ$ (6 o'clock)	60	70	-		
Response time	T_{ON}	Normal $\theta=\Phi=0^\circ$	-	10	20	msec	Note 3
	T_{OFF}		-	15	30	msec	Note 3
Contrast ratio	CR		400	500	-	-	Note 4
Color chromaticity	W_X		0.26	0.31	0.36	-	Note 2 Note 5 Note 6 (Without Touch Panel)
	W_Y		0.28	0.33	0.38	-	
Luminance	L_1		200	240	-		Note 6 (With Touch Panel)
	L_2		250	300	-		Note 6 (Without Touch Panel)
Luminance uniformity	Y_U	70	75	-	%	Note 7	

Test Conditions:

1. $V_{CC}=3.3V$, $I_L=20mA$ (Backlight current), the ambient temperature is $25^\circ C$.
2. The test systems refer to Note 2.

Note 1: Definition of viewing angle range

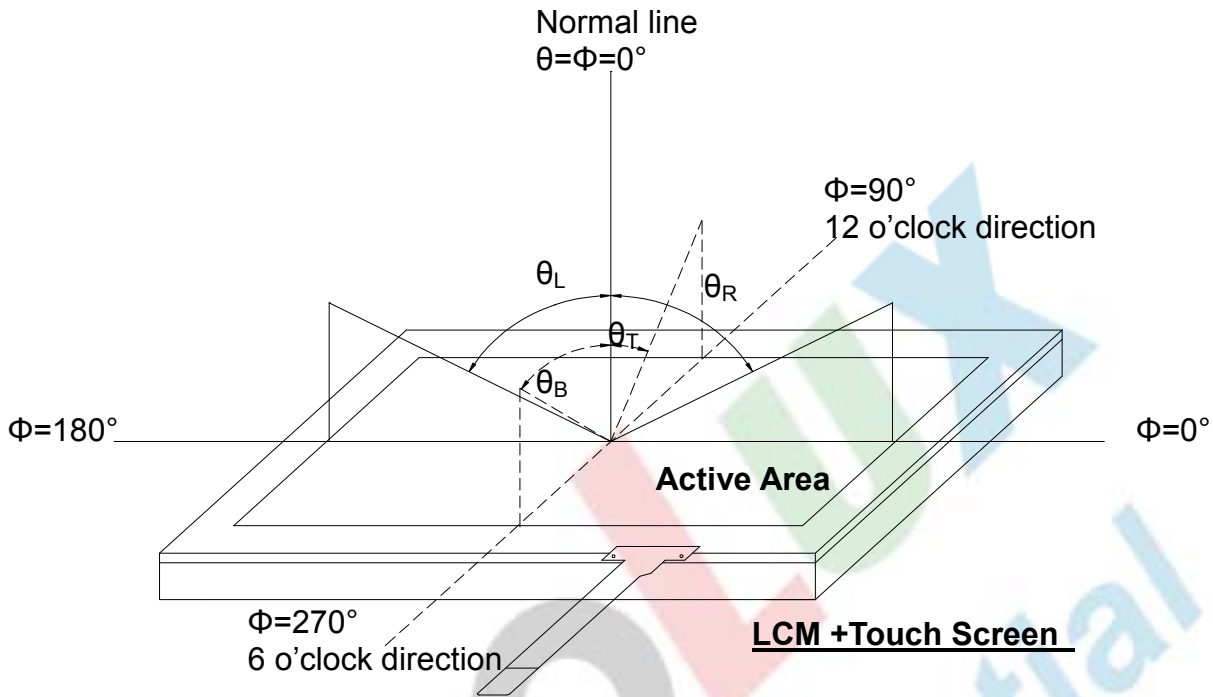

Fig. 4-1 Definition of viewing angle

Note 2: Definition of optical measurement system.

The optical characteristics should be measured in dark room. After 30 minutes operation, the optical properties are measured at the center point of the LCD screen. (Response time is measured by Photo detector TOPCON BM-7, other items are measured by BM-5A/Field of view: 1° /Height: 500mm.)

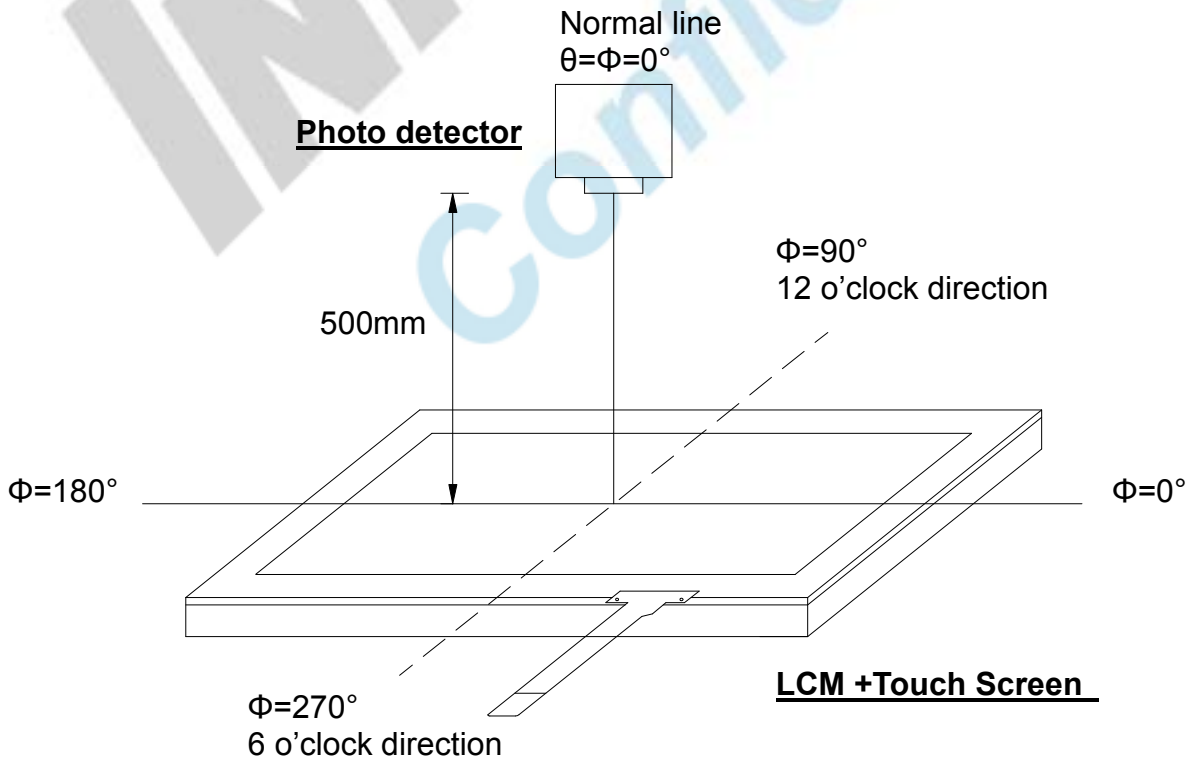

Fig. 4-2 Optical measurement system setup

版權屬於研創所有，禁止任何未經授權的使用

Note 3: Definition of Response time

The response time is defined as the LCD optical switching time interval between "White" state and "Black" state. Rise time (T_{ON}) is the time between photo detector output intensity changed from 90% to 10%. And fall time (T_{OFF}) is the time between photo detector output intensity changed from 10% to 90%.

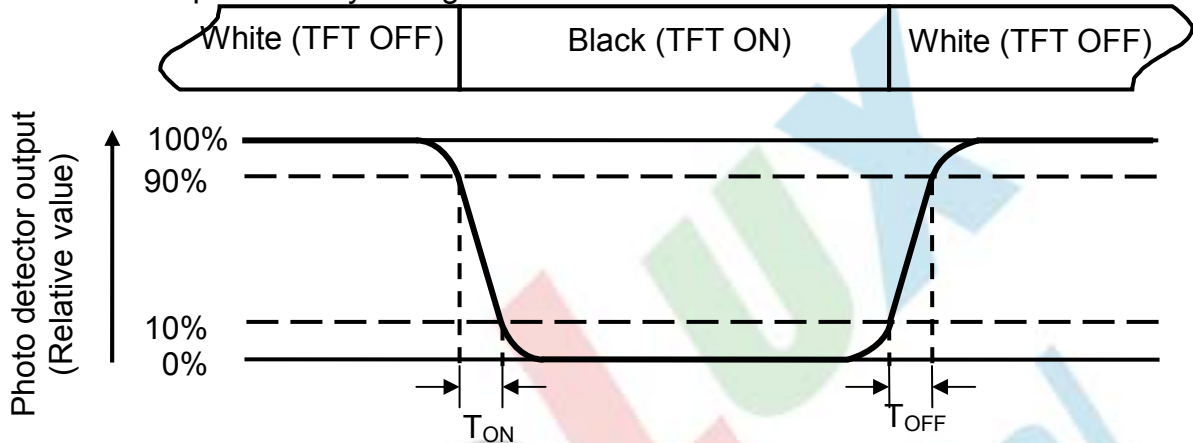

Fig. 4-3 Definition of response time

Note 4: Definition of contrast ratio

$$\text{Contrast ratio (CR)} = \frac{\text{Luminance measured when LCD on the "White" state}}{\text{Luminance measured when LCD on the "Black" state}}$$

Note 5: Definition of color chromaticity (CIE1931)

Color coordinates measured at center point of LCD.

Note 6: All input terminals LCD panel must be ground while measuring the center area of the panel. The LED driving condition is $I_L=20\text{mA}$ of which each LED module is 3 LED serial.

Note 7: Definition of Luminance Uniformity

Active area is divided into 9 measuring areas (Refer to Fig. 4-4).Every measuring point is placed at the center of each measuring area.

$$\text{Luminance Uniformity (Yu)} = \frac{B_{min}}{B_{max}}$$

L-----Active area length W----- Active area width

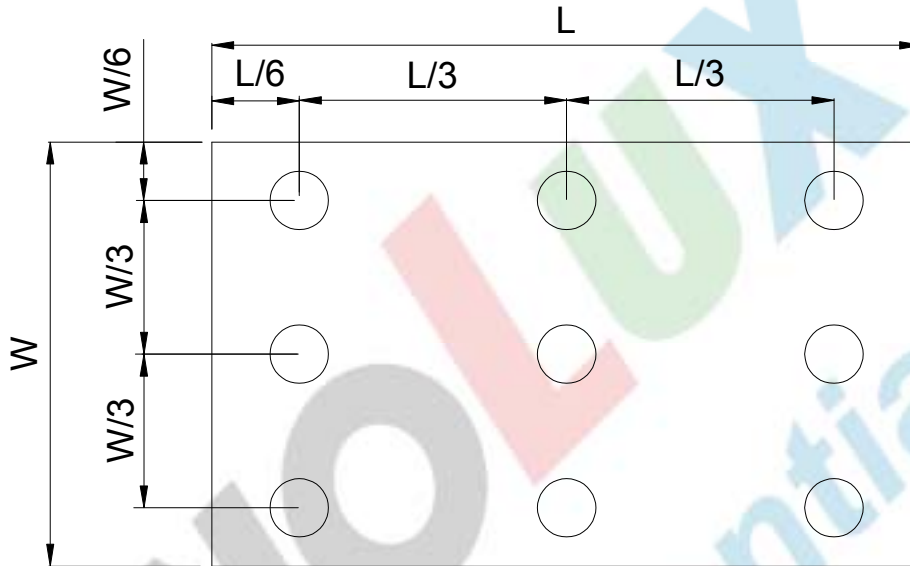

Fig. 4-4 Definition of measuring points

B_{max}: The measured maximum luminance of all measurement position.

B_{min}: The measured minimum luminance of all measurement position.

6. Reliability Test

6.1. Environmental Characteristics

Operating Temp.	-20°C~+70°C,20%RH~90%RH; Max wet temp. is 40°C ,none drops of dew
Storage Temp.	-30°C~+80°C,20%RH~90%RH; Max wet temp. is 40°C ,none drops of dew

6.2 Reliability Test Items

Item	Test Conditions	Remark
High Temperature Storage	Ta = 80°C 240 hrs	Note 1
Low Temperature Storage	Ta = -30°C 240hrs	Note 1
High Temperature Operation	Ts = 70°C 240hrs	Note 2
Low Temperature Operation	Ta =-20°C 240hrs	Note 1
Operate at High Temperature and Humidity	+40°C, 90%RH max. 240 hrs	
Thermal Shock	-30°C/30 min ~ +80°C/30 min for a total 100 cycles, Start with cold temperature and end with high temperature.	
Vibration Test	Frequency range:10~55Hz Stroke:1.5mm Sweep:10Hz~55Hz~10Hz 2 hours for each direction of X. Y. Z. (6 hours for total)	
Mechanical Shock	100G 6ms,±X, ±Y, ±Z 3 times for each direction	
Package Vibration Test	Random Vibration : 0.015G*G/Hz from 5-200HZ, -6dB/Octave from 200-500HZ 2 hours for each direction of X. Y. Z. (6 hours for total)	
Package Drop Test	Height:60 cm 1 corner, 3 edges, 6 surfaces	
Electro Static Discharge	± 2KV, Human Body Mode, 100pF/1500Ω	

Note 1: T_a is the ambient temperature of samples.

Note 2: T_s is the temperature of panel's surface.

Note 3: In the standard condition, there shall be no practical problem that may affect the display function. After the reliability test, the product only guarantees operation, but doesn't guarantee all the cosmetic specification.

INNOLUX
Confidential

7. General Precautions

7.1. Safety

Liquid crystal is poisonous. Do not put it in your mouth. If liquid crystal touches your skin or clothes, wash it off immediately by using soap and water.

7.2. Handling

1. The LCD panel is plate glass. Do not subject the panel to mechanical shock or to excessive force on its surface.
2. The polarizer attached to the display is easily damaged. Please handle it carefully to avoid scratch or other damages.
3. To avoid contamination on the display surface, do not touch the module surface with bare hands.
4. Keep a space so that the LCD panels do not touch other components.
5. Put cover board such as acrylic board on the surface of LCD panel to protect panel from damages.
6. Transparent electrodes may be disconnected if you use the LCD panel under environmental conditions where the condensation of dew occurs.
7. Do not leave module in direct sunlight to avoid malfunction of the ICs.

7.3. Static Electricity

1. Be sure to ground module before turning on power or operating module.
2. Do not apply voltage which exceeds the absolute maximum rating value.

7.4. Storage

1. Store the module in a dark room where must keep at $25\pm 10^{\circ}\text{C}$ and 65%RH or less.
2. Do not store the module in surroundings containing organic solvent or corrosive gas.
3. Store the module in an anti-electrostatic container or bag.

7.5. Cleaning

1. Do not wipe the polarizer with dry cloth. It might cause scratch.
2. Only use a soft sloth with IPA to wipe the polarizer, other chemicals might permanent damage to the polarizer.

8. Mechanical Drawing

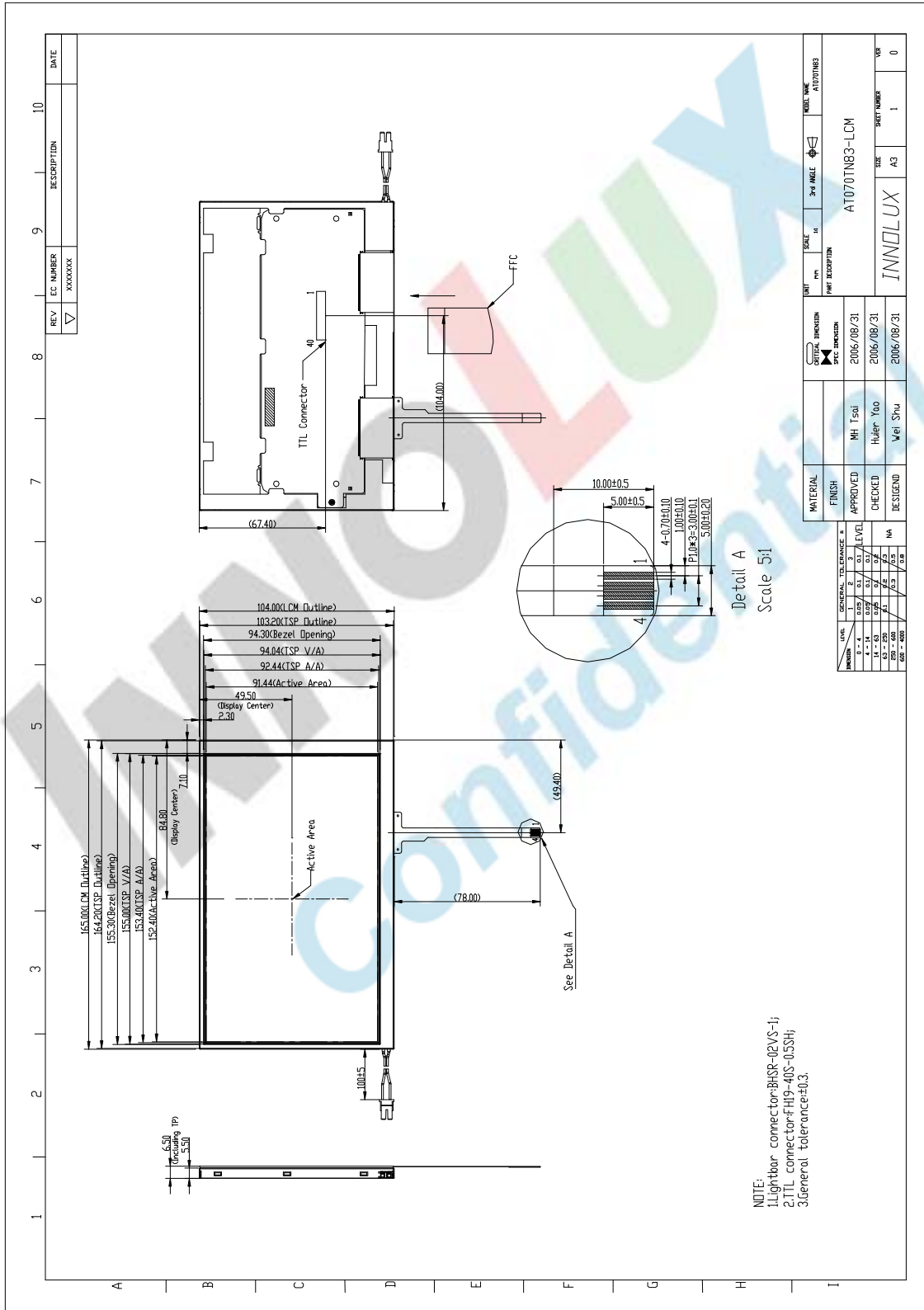

版權屬於群創所有，禁止任何未經授權的使用

The copyright belongs to InnoLux. Any unauthorized use is prohibited.

9. Package Drawing

9.1. Packaging Material Table

No.	Item	Model (Material)	Dimensions(mm)	Unit Weight (kg)	Quantity	Remark
1	LCM Module	AT070TN83	165X104X6.5	0.160	50pcs	
2	Partition	BC Corrugated Paper	512×349×226	1.466	1 set	
3	Corrugated Bar	B Corrugated Paper	512X11X3	0.046	4 set	
4	Dust-Proof Bag	PE	700X530	0.048	1 pcs	
5	A/S Bag	PE	180×160×0.05	0.002	50 pcs	
6	Carton	Corrugated paper	530*355*255	1.100	1 pcs	
7	Total weight	10.898kg±5%				

9.2. Packaging Quantity

Total LCM quantity in Carton: no. of Partition	2 Rows x	quantity per Row	25	= 50
--	----------	------------------	----	------

9.3. Packaging Drawing

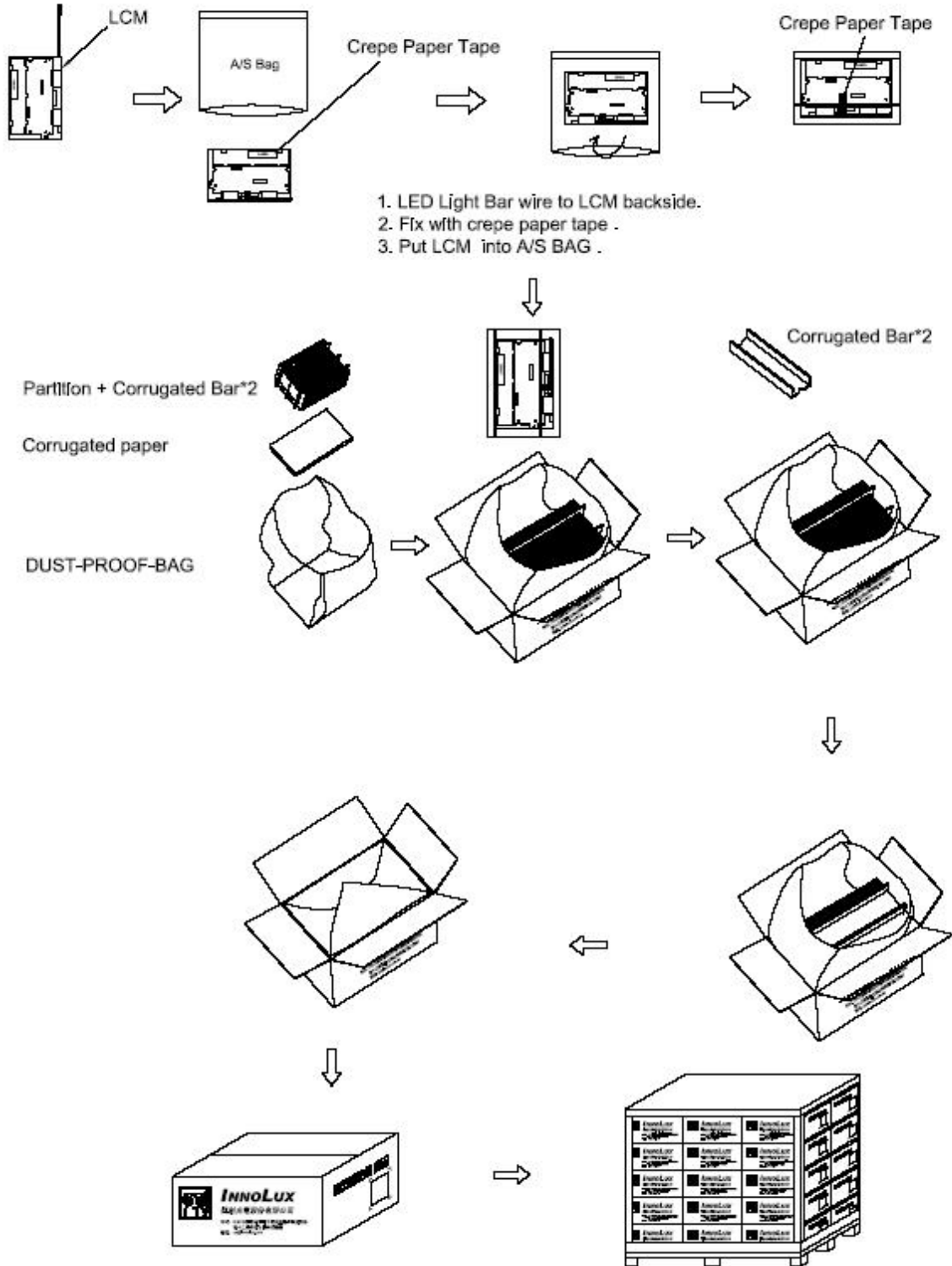

版權屬於群創所有，禁止任何未經授權的使用

The copyright belongs to InnoLux. Any unauthorized use is prohibited.