

ALLEN & HEATH



Xone:92 PROFESSIONAL DJ MIXER

SERVICE MANUAL

Publication AP5296

Introduction

This publication provides technical information on servicing the Allen & Heath **XONE:92**. Included are system block diagram, internal layout drawing and circuit schematics with board layouts. Whilst we believe this information to be reliable we do not assume responsibility for inaccuracies. We also reserve the right to make changes in the interest of further product development.

Additional Resources

Allen & Heath web site	www.allen-heath.com	Product information Technical downloads Distribution contacts Company contacts
Technical support	support@allen-heath.com	See web for local contact
Xone:92 user guide	AP5345	Operating instructions Performance specification User jumper link options

Xone:92 Service Information

Issue status: **xone92_ap5296_3.doc**

Print date: **04 November 2004**

Copyright © 2004 Allen & Heath. All rights reserved

ALLEN&HEATH

Manufactured in the United Kingdom by Allen & Heath

Kernick Industrial Estate, Penryn, Cornwall, TR10 9LU, UK

<http://www.allen-heath.com>



Servicing Precautions – General Notes

- Service personnel:** Service work should be carried out by technically qualified service personnel only. Mains power is dangerous and can kill. Do not attempt to work on a linear or switched mode power supply if you are not suitably qualified to do so. Do not attempt to repair surface mount circuit assemblies unless you are suitably qualified and have the necessary facilities to do so. Replacement circuit assemblies can be ordered.
- Service facilities:** Ensure a suitably sized work surface is available. Ensure this is clear of dirt, debris and obstructions which may damage the equipment surfaces. Ensure adequate lighting. Use the correct tools for the job and ensure they are in good working order. Ensure all workshop safety requirements are adhered to.
- Service information:** Check that you have all the information you need before starting the service job. Refer to the Allen & Heath web site or contact Allen & Heath technical support for details on the latest information. Full technical information can be downloaded from the web site Distributor Zone (password required).
- Mains power:** Connect the equipment to mains power only of the type described in the user guide and marked on the rear panel. The power source must provide a good ground connection. Ensure you always use an isolation transformer when working on any mains power supply unit.
- Mains cord and fuse:** Use the correct power cord as supplied with the equipment. Do not remove or tamper with the ground connection in the power cord. Heed the Important Mains Plug Wiring Instructions printed in the user guide if it is necessary to rewire the mains cord. Always replace the equipment mains fuse with the correct type and rating as described in the user guide and marked on the equipment panel.
- Opening the unit:** Switch off and remove the mains power cord before opening the equipment. Ensure all power supply covers and safety shields are in place before applying power with the unit open for diagnostic fault finding.
- Closing the unit:** Before finishing, check the quality and accuracy of the service work carried out. Remove any dirt or debris as this may cause equipment failure in the future. Ensure all assemblies, harnesses and connectors are correctly aligned and plugged in. Ensure that jumper settings and control configurations are correctly set according to the requirements of the customer.
- Testing the unit:** Before operating the equipment, read and adhere to the Important Safety Instructions printed in the user guide. Test that the service work has been successfully carried out.
- Shipping the unit:** Use adequate packing such as the original packaging or purpose designed flight case if you need to ship the unit. To avoid injury to yourself or damage to the equipment take care when lifting, moving or carrying the equipment.



Servicing Notes – XONE:92

- User maintenance:** There are several user configurable jumper links inside. These are described in the user guide together with instructions on how to change the default settings.
- Technology:** The XONE:92 uses SMT (surface mount) PCB technology. In certain cases it may be better to replace a faulty assembly rather than try to fix it without the appropriate tools and training. The power supply is a built-in universal mains input, switched mode circuit which should be serviced by suitably qualified personnel only.
- Operation:** The XONE:92 is a performance club mixer. To ensure optimum performance and reliability it should be connected and operated as described in the user guide.
- Fault finding:** Refer to the system block diagram and circuit drawings to follow through the signal path during fault diagnosis. Replace suspected faulty components only with those specified by Allen & Heath. The use of lower grade alternatives may degrade the performance. Ensure the RCA phono insert jumper links are pressed fully in if fitted.

Contents Log

XONE:92 – Historical Change Log	xone92_ap5296_3.pdf
Removing the Top Panel	xone92_top_panel_removal_1.pdf
Internal Layout drawing	xone92_layout_1.pdf
Surface and Main Parts.....	xone92_parts_2.pdf
Block Diagram.....	xone92_blockdiagram_2.pdf
Stereo Fader PCB Assembly	xone92_002-684_stereo_fader_3.pdf
Mic/Stereo Return PCB Assy	xone92_003-136_mic_stereoreturn_2.pdf
Stereo Input PCB Assembly	xone92_003-137_stereo_3.pdf
Filter 1 & 2 PCB Assembly iss.2	xone92_003-138_143_filter_2.pdf
Filter 1 & 2 PCB Assembly iss.3	xone92_003-138_143_filter_3.pdf
Master PCB Assembly	xone92_003-139_master_2.pdf
Crossfader PCB Assembly	xone92_003-140_xfade_2.pdf
Slave PCB Assembly	xone92_003-141_slave_2.pdf
Connector PCB Assembly	xone92_003-142_connector_1.pdf
Linear Fader PCB Assembly.....	xone92_003-144_linear_fader_1.pdf
Rotary Fader PCB Assembly	xone92_003-145_rotary_fader_2.pdf
PSU PCB Assembly	xone92_003-233_psu_2.pdf
XONE:92 – Engineering Change Notes	xone92_ecns_1.pdf

XONE:92 – Historical Change Log

The following list identifies historical changes to the **XONE:92**. The effective dates, serial numbers and related change note documentation are included for reference to help identify the correct issue circuit boards and components. Whilst we believe this information to be reliable we do not assume responsibility for inaccuracies. We also reserve the right to make changes in the interest of further product development.

Assembly	Description	From Serial Number	Date	Change Note Number
003-138/143	Filter 1 & Filter 2 iss.1 PCB mod	-	11/03/04	984
003-138/143 & 003-141	Filter value change + diode addition	060507	25/02/04	993
003-233	IEC Mains Filter with Nutserts	-	29/03/04	998
003-139	Master PCB output level change	063122	21/04/04	1018
003-141	Slave PCB capacitor change	063515	04/05/04	1020
User Guide	Issue 2 Block Diagram – Mix 1 output level changed from 0dBu to +4dBu	-	26/05/04	1026
003-138/143	Filter 1 & 2 PCBs up-issue to iss.3	064869	13/05/04	1036

Removing the Top Panel Assembly

To gain access to the PCB assemblies the top panel assembly needs to be separated from the chassis. This operation should only be carried out by qualified service personnel.

IMPORTANT! Disconnect mains input lead before removing the top panel

Removal of the top panel requires the use of a Torx T10 screwdriver. Use a good quality tool to prevent rounding the screw heads. First remove the 4 pipped TORX screws located on rear panel in the center of each block of input channel RCA (Phono) connectors, and then undo the 8 M3 x 8 screws that hold the front panel to the chassis. Lift the front edge of the top panel until the two filter PCBs are clear of the chassis, and then pull the top panel gently forward and up until access can be gained to unplug the power cable from the power supply located on the right hand side of the chassis. Continue to lift the front edge of the top panel up until it is possible to unplug the two harnesses from the rear connector PCB. Lift the top panel clear of the base and place on a clear work surface.

Reassembly is the reverse procedure, but take great care to fit the harnesses correctly and to ensure that the ribbon cables do not get trapped between any of the PCBs and the chassis. Refit the panel screws first and tighten evenly with the chassis held firmly on a flat work surface. Finally refit the rear connector screws.

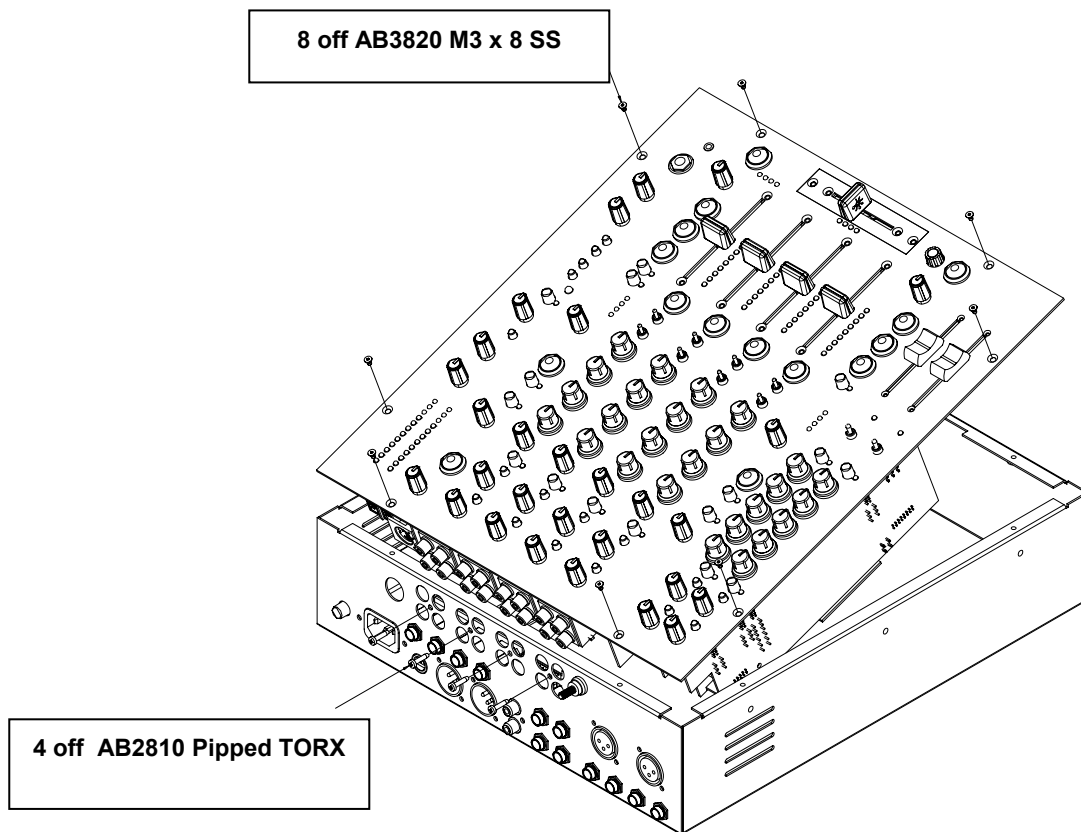

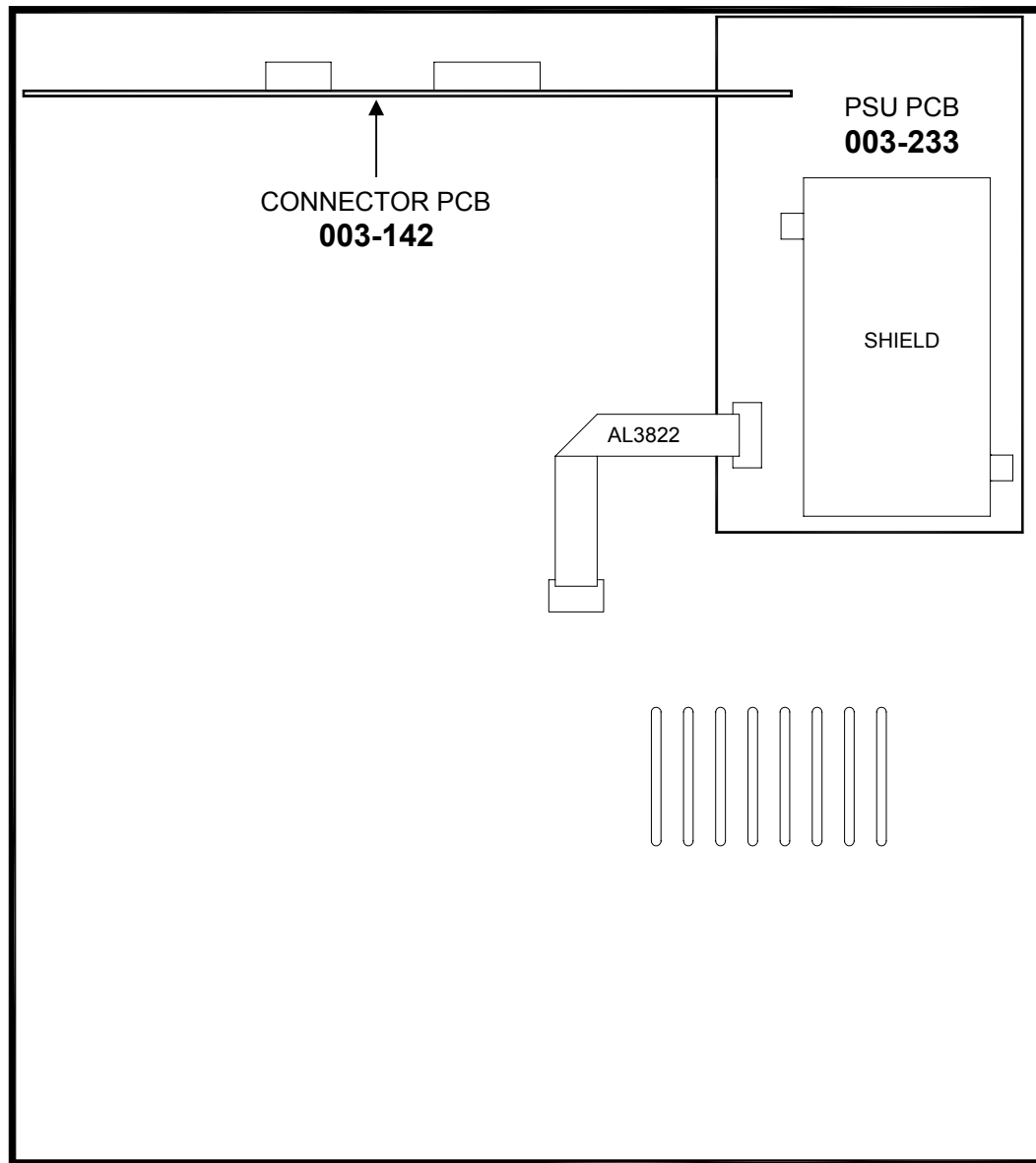

XONE:92 Chassis assembly Front view

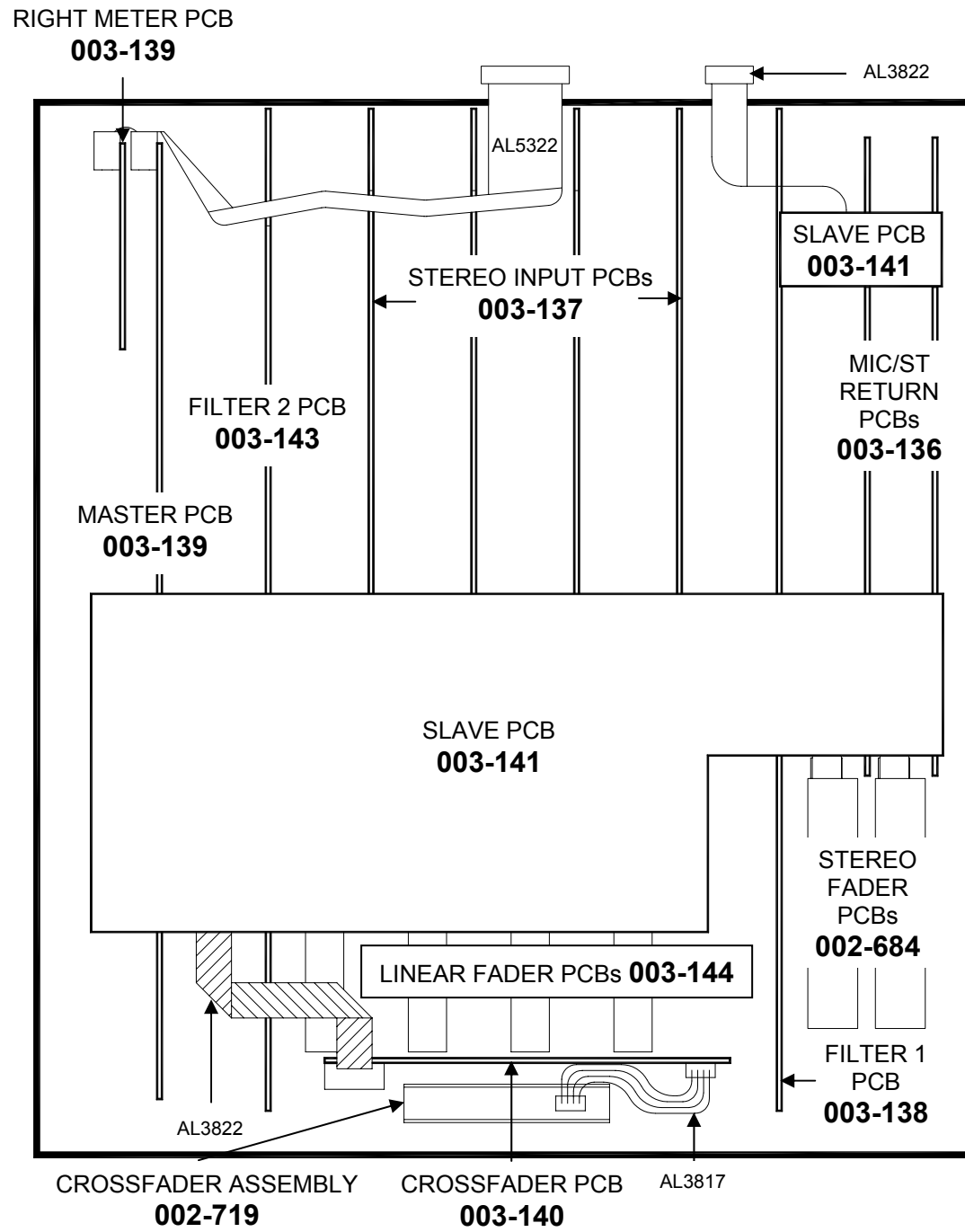

XONE:92 Front Panel assembly Front view

ROTARY versions use ROTARY FADER PCB **003-145** instead of **003-144**

Product.....XONE:92-R/100
.....XONE:92-R/110
.....XONE:92-R/120
.....XONE:92-R/220
.....XONE:92-R/240
..... XONE:92/110
..... XONE:92/120
..... XONE:92/220
..... XONE:92/240
Pack Assembly..... 003-132
Main Assembly (Linear)..... 003-133
Top Panel Assembly (Linear)... 003-134
Chassis Assembly..... 003-135
Main Assembly (Rotary)..... 003-146
Top Panel Assembly (Rotary). . 003-147

Stereo Fader PCB 002-684
Mic/Stereo Return PCB 003-136
Stereo Input PCB 003-137
Filter 1 PCB 003-138
Master PCB 003-139
Crossfader PCB 003-140
Slave PCB 003-141
Connector PCB 003-142
Filter 2 PCB 003-143
Linear Fader PCB..... 003-144
Rotary Fader PCB 003-145
Mains/PSU PCB 003-233

Spare P&G Crossfader Assy.... 002-719

XONE:92 Surface Parts

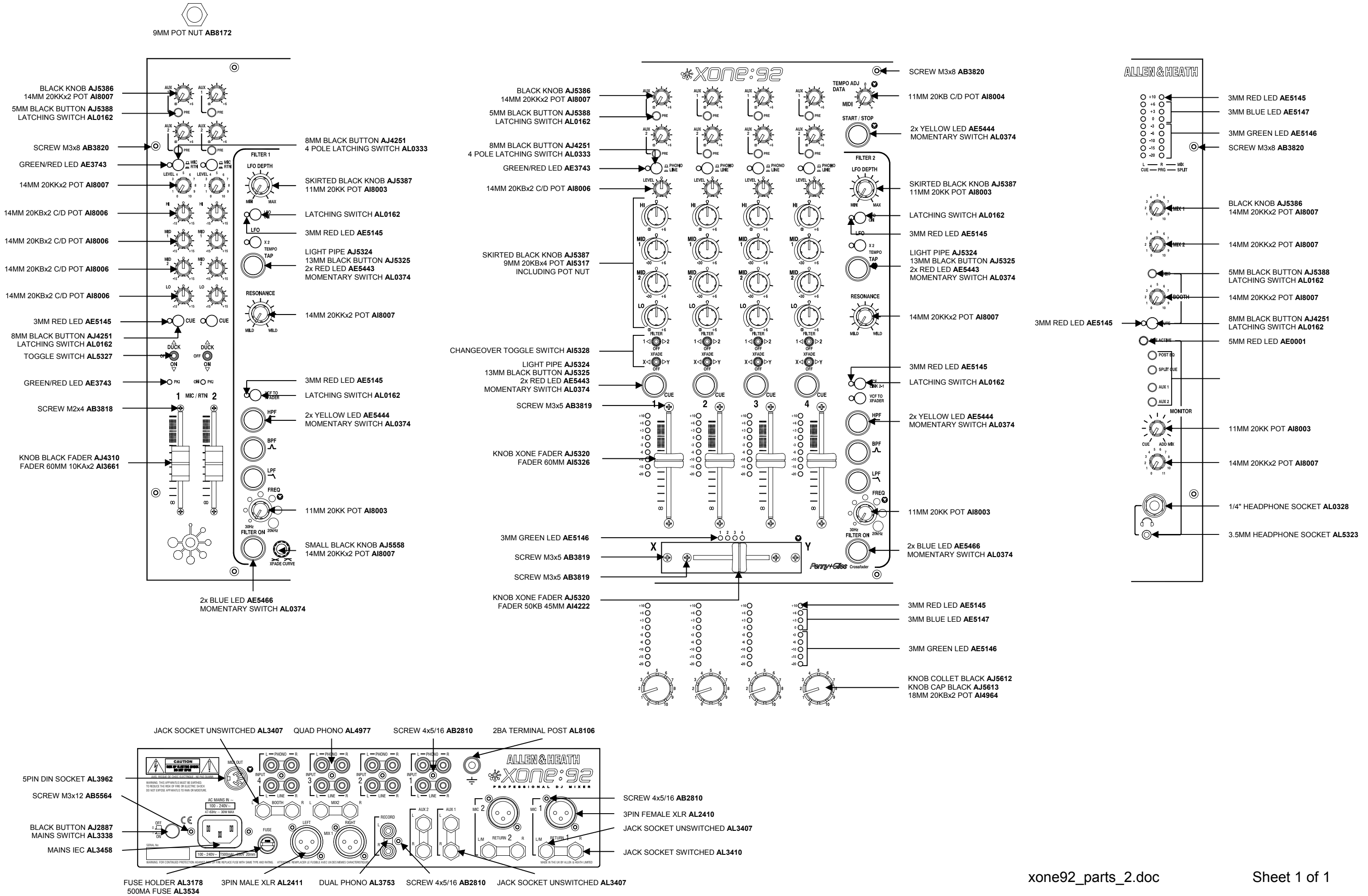

XONE:92 BLOCK DIAGRAM

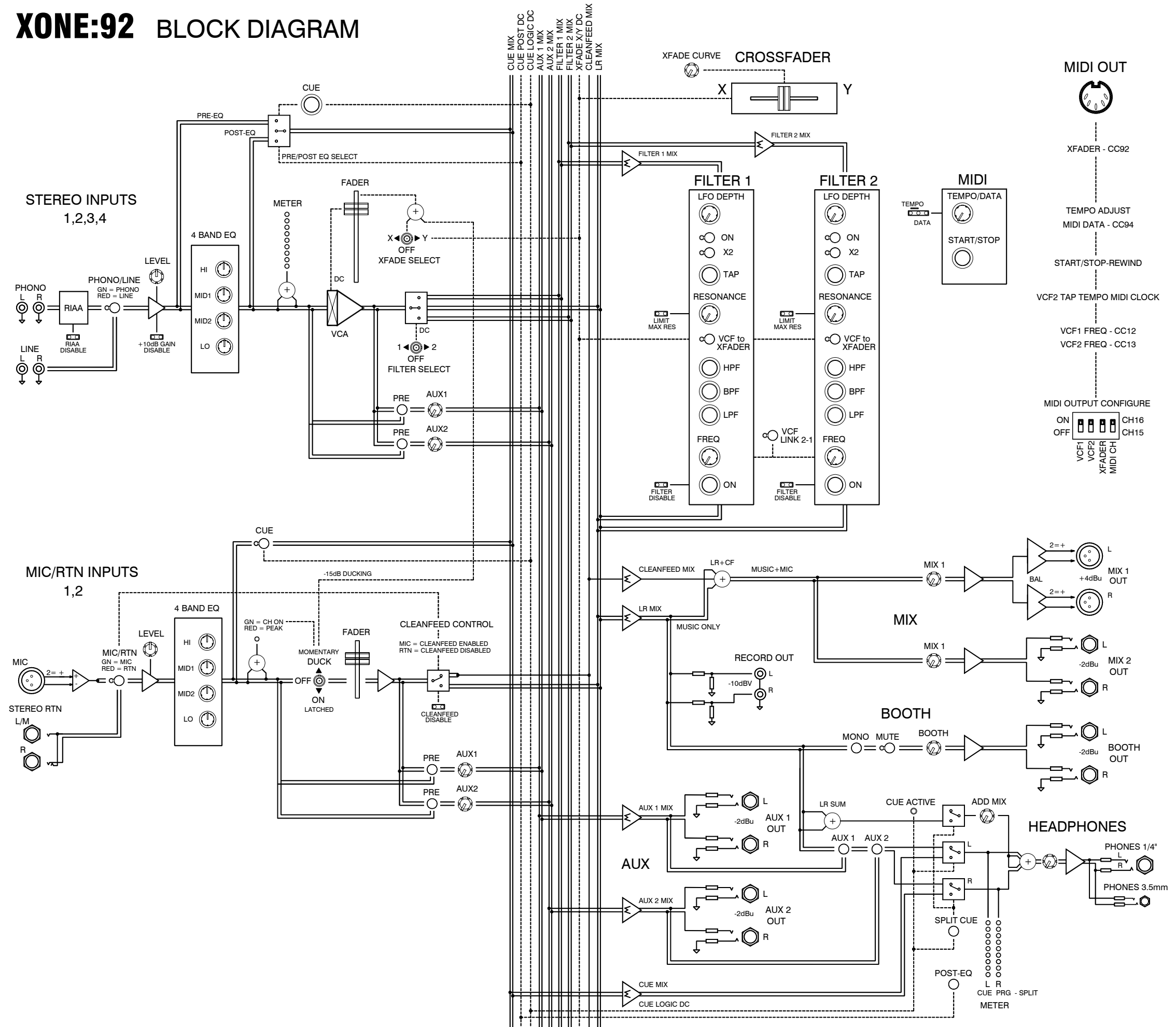

e

d

c

b

a

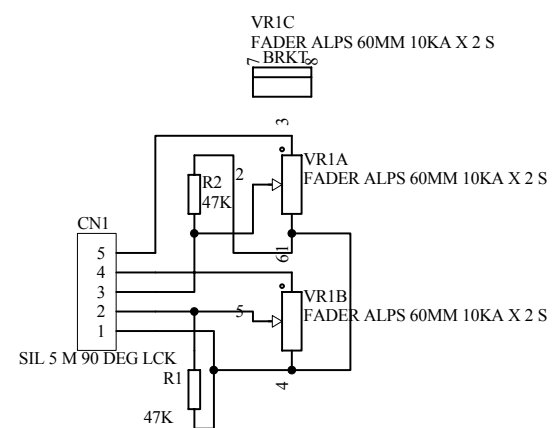

ALLEN&HEATH
 Kernick Industrial Estate,
 Penryn, Cornwall,
 England. TR10 9LU
 Tel: +44 (0)8707 556250
 Fax: +44 (0)8707 556251

ISSUE	BY	DATE
3	ARJ/AA	29-11-01

FILE: C4268_3 PRINTED: 13:31:15 21-Sep-2004

TITLE: **XONE 92 STEREO FADER**
 PAGE:
 DRG No: C4268 ISSUE: 3 SHEET: 1 OF 1

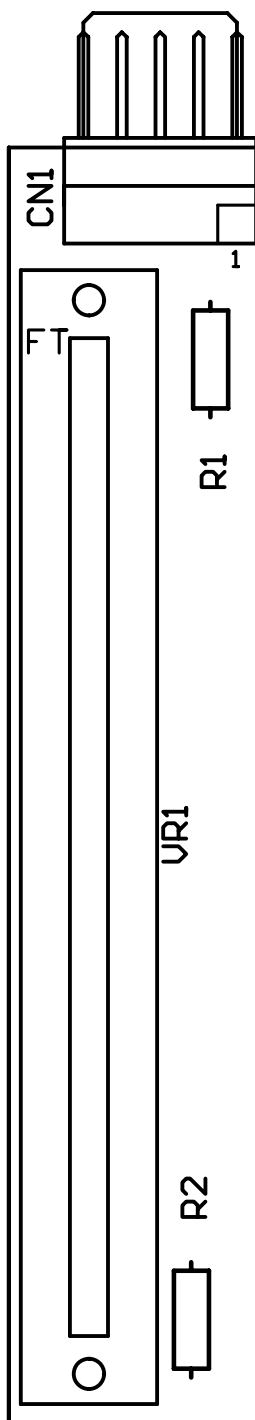

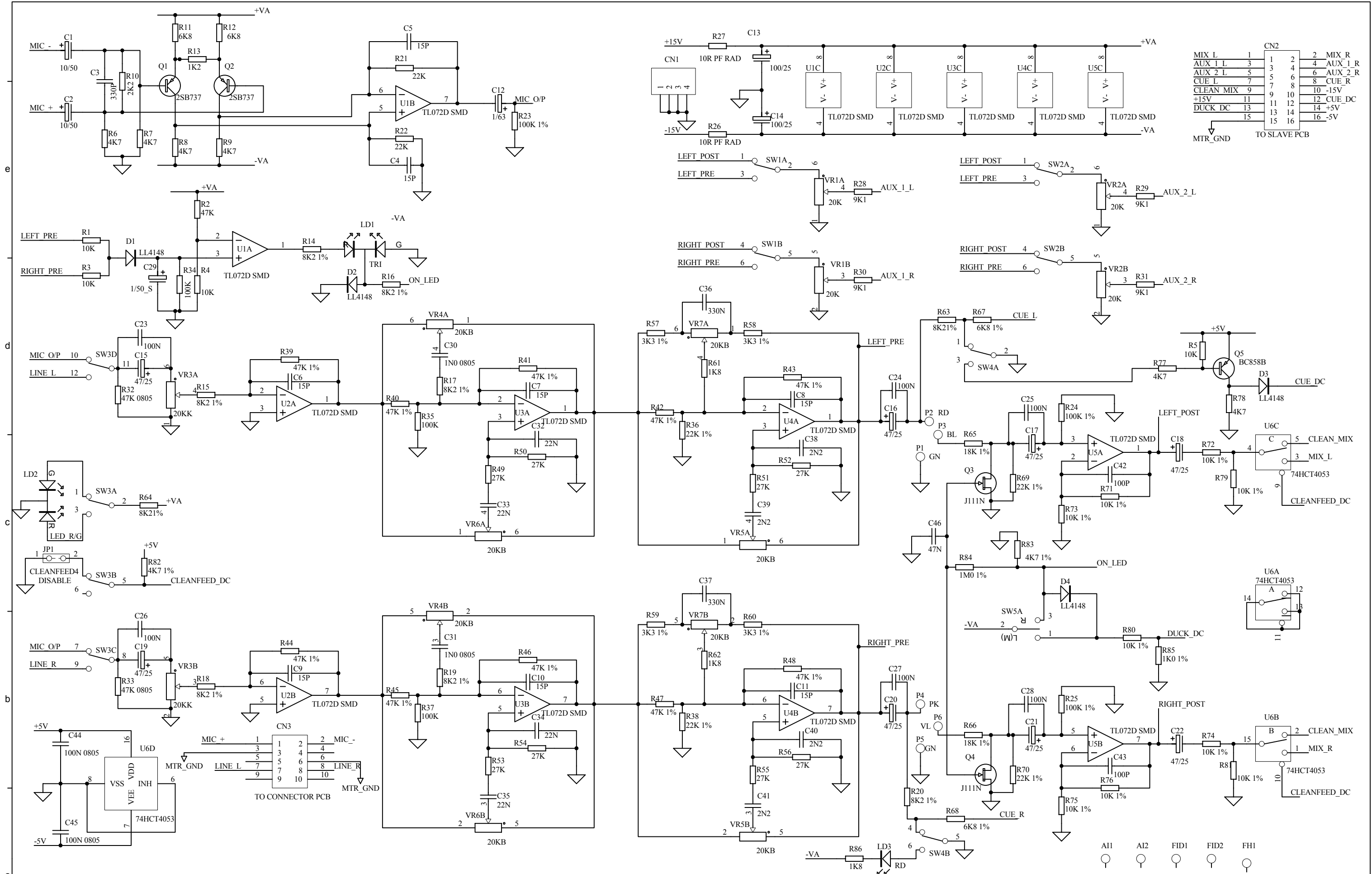

CN1		CN2	
MIX L	1	1	2 MIX_R
AUX 1 L	3	3	4 AUX_1_R
AUX 2 L	5	5	6 AUX_2_R
CUE L	7	7	8 CUE_R
CLEAN MIX	9	9	10 -15V
+15V	11	11	12 CUE_DC
DUCK DC	13	13	14 +5V
	15	15	16 -5V

MTR_GND TO SLAVE PCB

ALLEN&HEATH
 Kernick Industrial Estate,
 Penryn, Cornwall,
 England. TR10 9LU
 Tel: +44 (0)8707 556250
 Fax: +44 (0)8707 556251

ISSUE	BY	DATE	CHK BY
1	ARJ	07-11-03	
2	ARJ	18-03-04	

BRKT	BRKT	BRKT	BRKT	BRKT	BRKT	BRKT	BRKT
SW5B	VR7C	VR6C	VR5C	VR4C	VR3C	VR2C	VR1C

FILE: AG5298 Iss 2.Sch

TITLE: **XONE 92 MIC/STEREO RTN**
 PAGE:
 DRG No: **C5298** ISSUE: **2** SHEET: **1 OF 1**

PRINTED: 10:00:07 21-Sep-2004

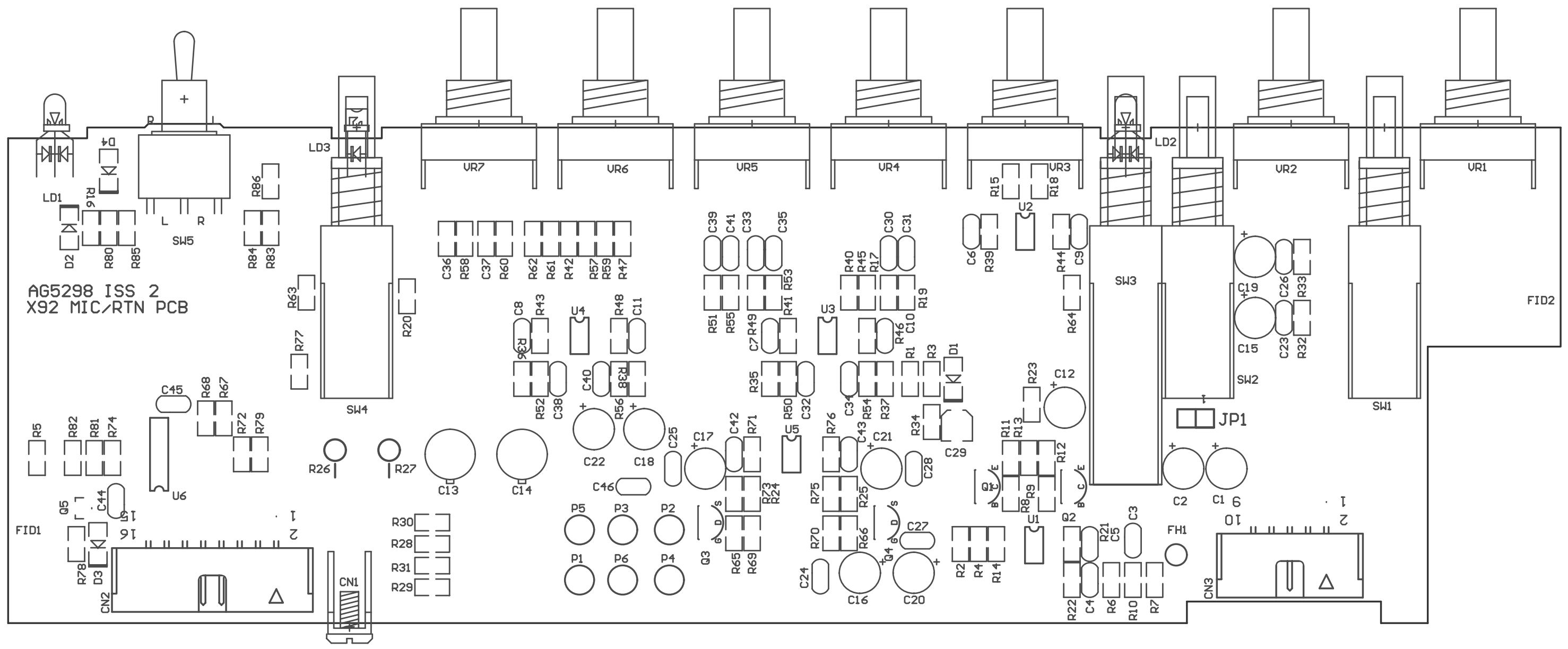

AG5298 ISS 2
X92 MIC/RTN PCB

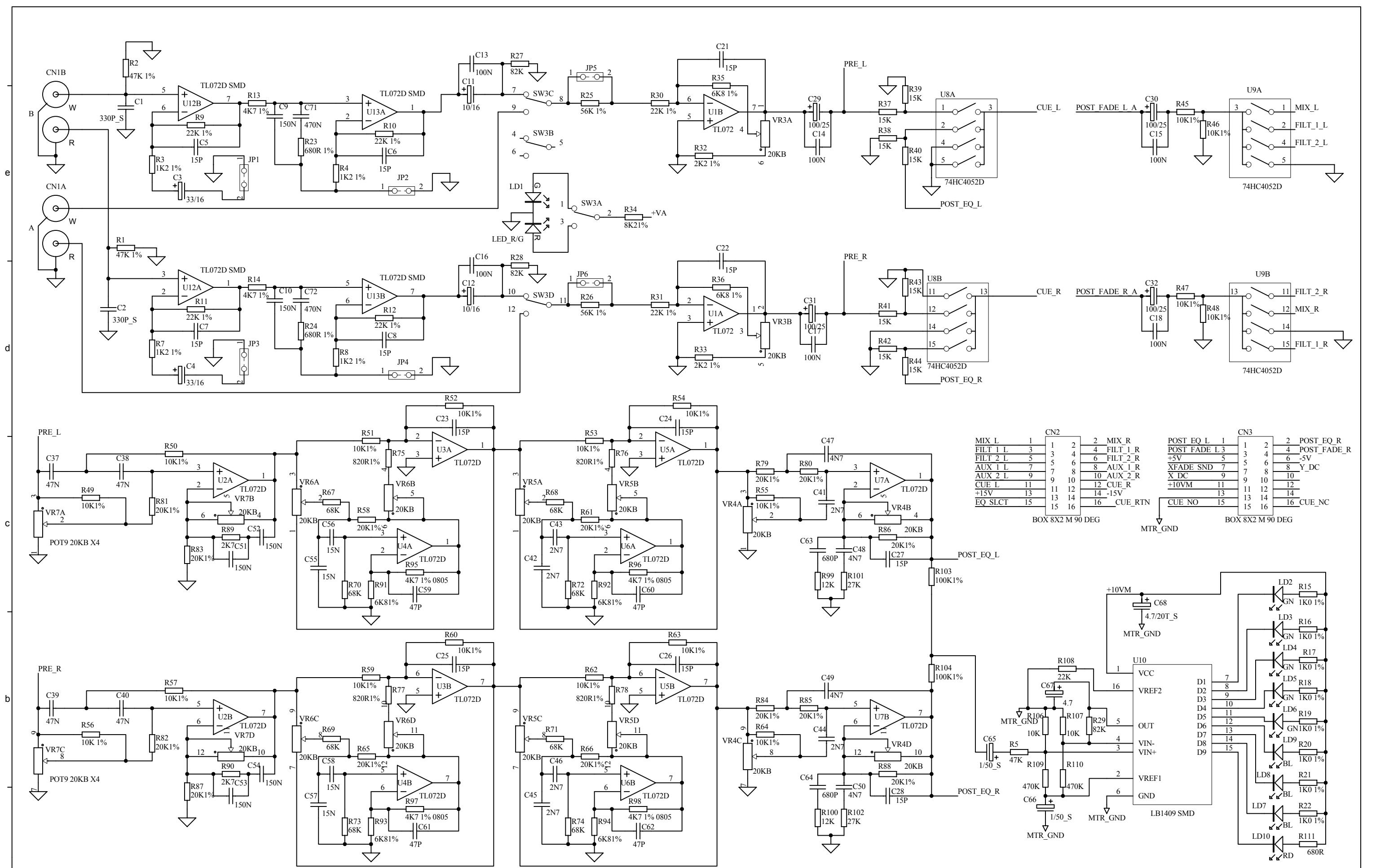

MIX L	1	2	MIX R	1	2	POST EQ_R
FILT 1 L	3	4	FILT 1_R	3	4	POST_FADE_R
FILT 2 L	5	6	FILT 2_R	5	6	-5V
AUX 1 L	7	8	AUX 1_R	7	8	Y_DC
AUX 2 L	9	10	AUX 2_R	9	10	10
CUE L	11	12	CUE R	11	12	12
+15V	13	14	-15V	13	14	14
EQ SLCT	15	16	CUE RTN	15	16	16

BOX 8X2 M 90 DEG

ALLEN&HEATH
 Kernick Industrial Estate,
 Penryn, Cornwall,
 England. TR10 9LU
 Tel: +44 (0)8707 556250
 Fax: +44 (0)8707 556251

ISSUE	BY	DATE	CHK BY
1	ARJ	07-11-03	
2	ARJ	18/12/03	
3	ARJ	18/03/04	

FILE: AG5299 ISS 3 Stereo SHEET 1

PRINTED: 10:05:12 21-Sep-2004

TITLE: XONE 92 STEREO CHANNEL
 PAGE:
 DRG No: C5299 ISSUE: 3 SHEET: 1 OF 2

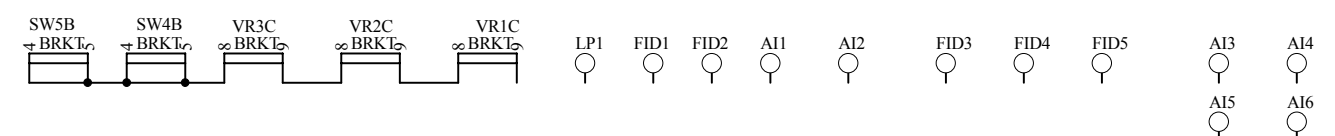
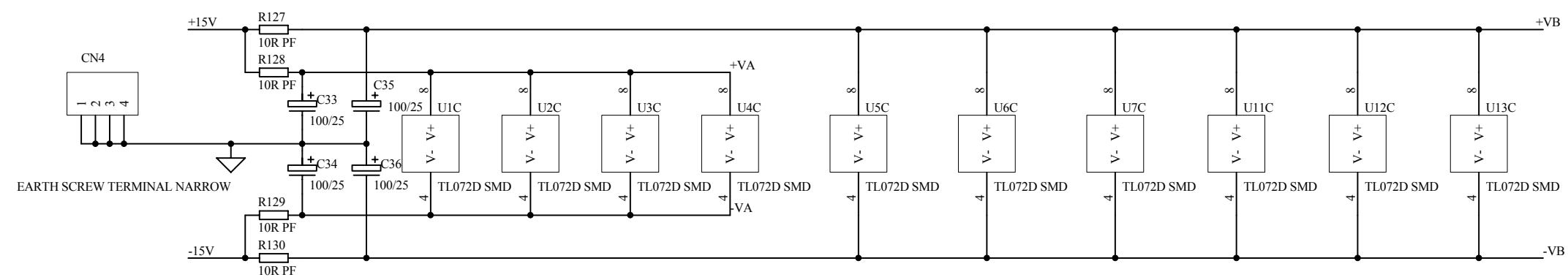
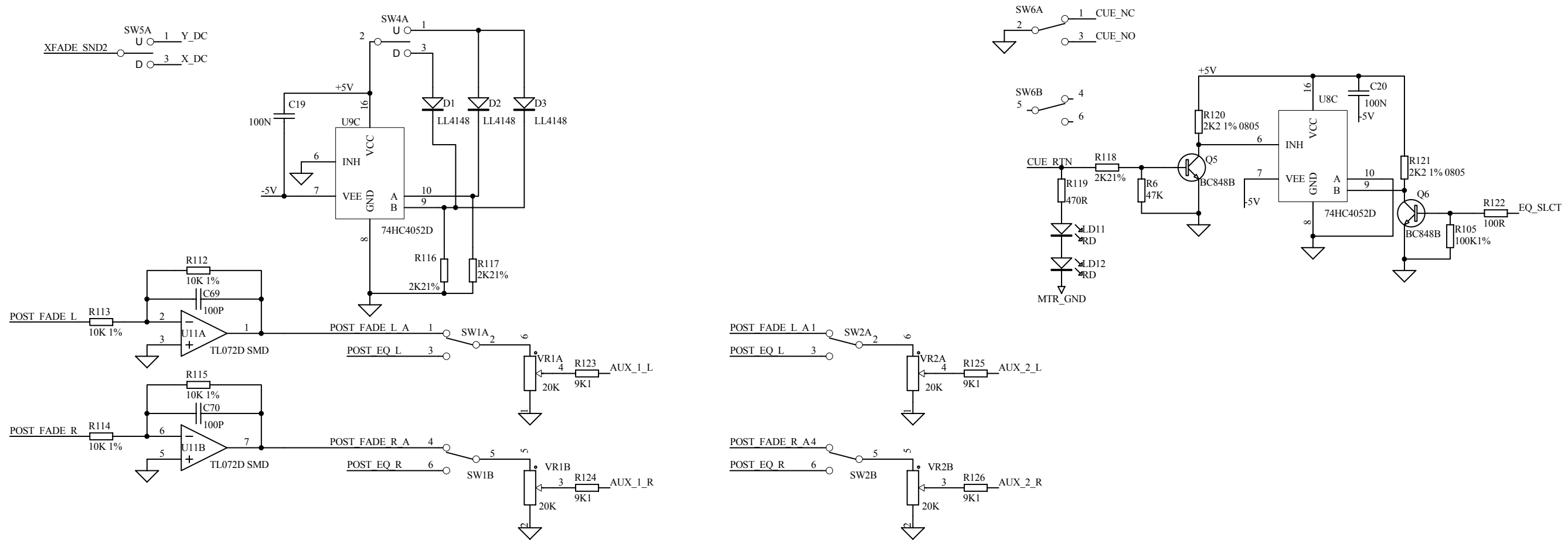

ALLEN&HEATH Kernick Industrial Estate, Penryn, Cornwall, England. TR10 9LU Tel: +44 (0)8707 556250 Fax: +44 (0)8707 556251	ISSUE	BY	DATE	CHK BY	TITLE: XONE 92 STEREO CHANNEL PAGE: DRG No: C5299 ISSUE: 3 SHEET: 2 OF 2
	1	ARJ	07-11-03		
	2	ARJ	18/12/03		
	3	ARJ	18/03/04		FILE: AG5299 ISS 3 Stereo SHEET 2 PRINTED: 10:05:13 21-Sep-2004

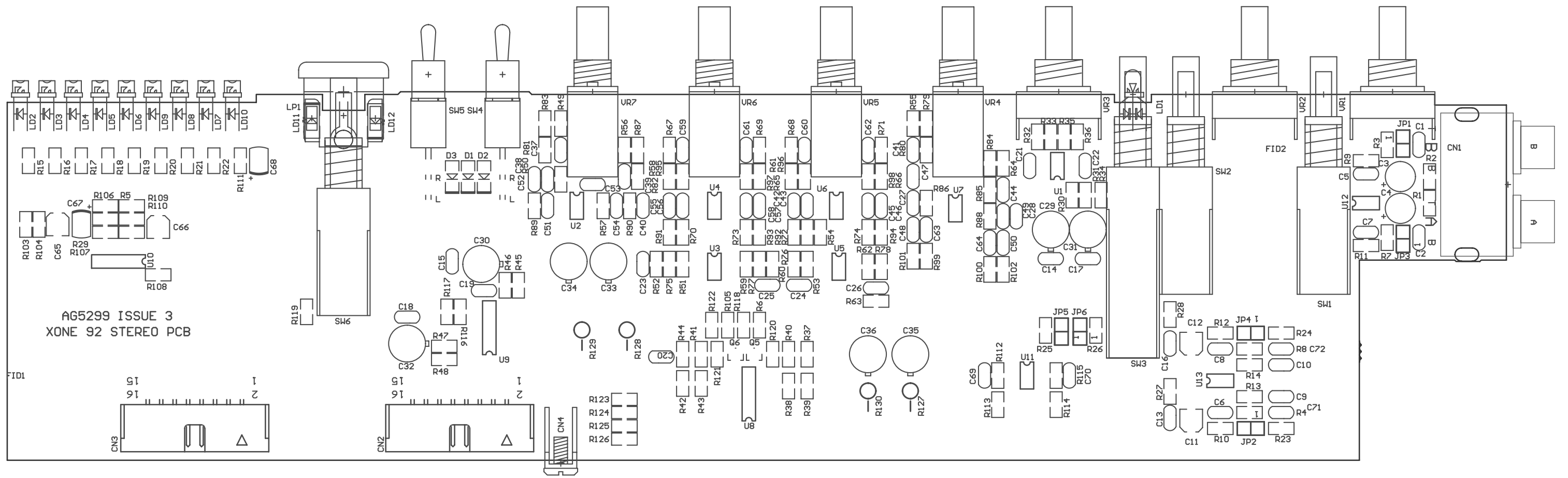

FILTER SWITCH LOGIC

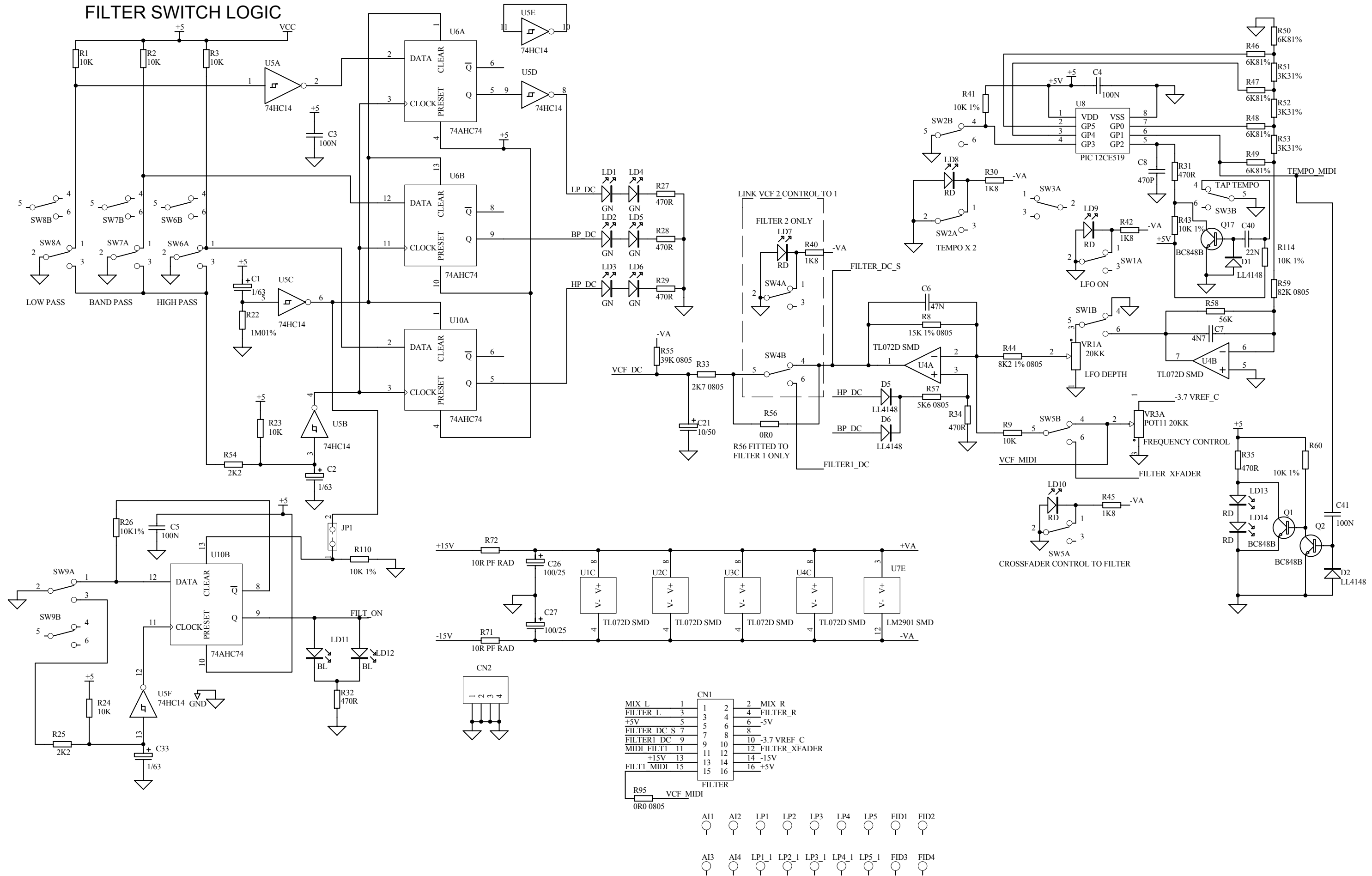

CN1		CN2	
1	MIX_L	1	AI1
2	MIX_R	2	AI2
3	FILTER_L	3	LP1
4	FILTER_R	4	LP2
5	+5V	5	LP3
6	-5V	6	LP4
7	FILTER_DC_S	7	LP5
8		8	FID1
9	FILTER1_DC	9	FID2
10	-3.7 VREF_C	10	AI3
11	MIDI_FILT1	11	AI4
12	FILTER_XFADER	12	LP1_1
13	+15V	13	LP2_1
14	-15V	14	LP3_1
15	FILT1_MIDI	15	LP4_1
16	+5V	16	LP5_1

ALLEN&HEATH
 Kernick Industrial Estate,
 Penryn, Cornwall,
 England. TR10 9LU
 Tel: +44 (0)8707 556250
 Fax: +44 (0)8707 556251

ISSUE	BY	DATE	CHK BY
1	ARJ	07-11-03	
2	ARJ	18-12-03	

VR2C	VR1B	VR3B
POT14 20KK X2	POT11 20KK	POT11 20KK

FILE: AG5300 ISS 2 SHEET 1.SCH

TITLE: XONE 92 FILTER/MIDI PCB
 PAGE:
 DRG No: C5300 ISSUE: 2 SHEET: 1 OF 3

PRINTED: 16:15:56 12-Feb-2004

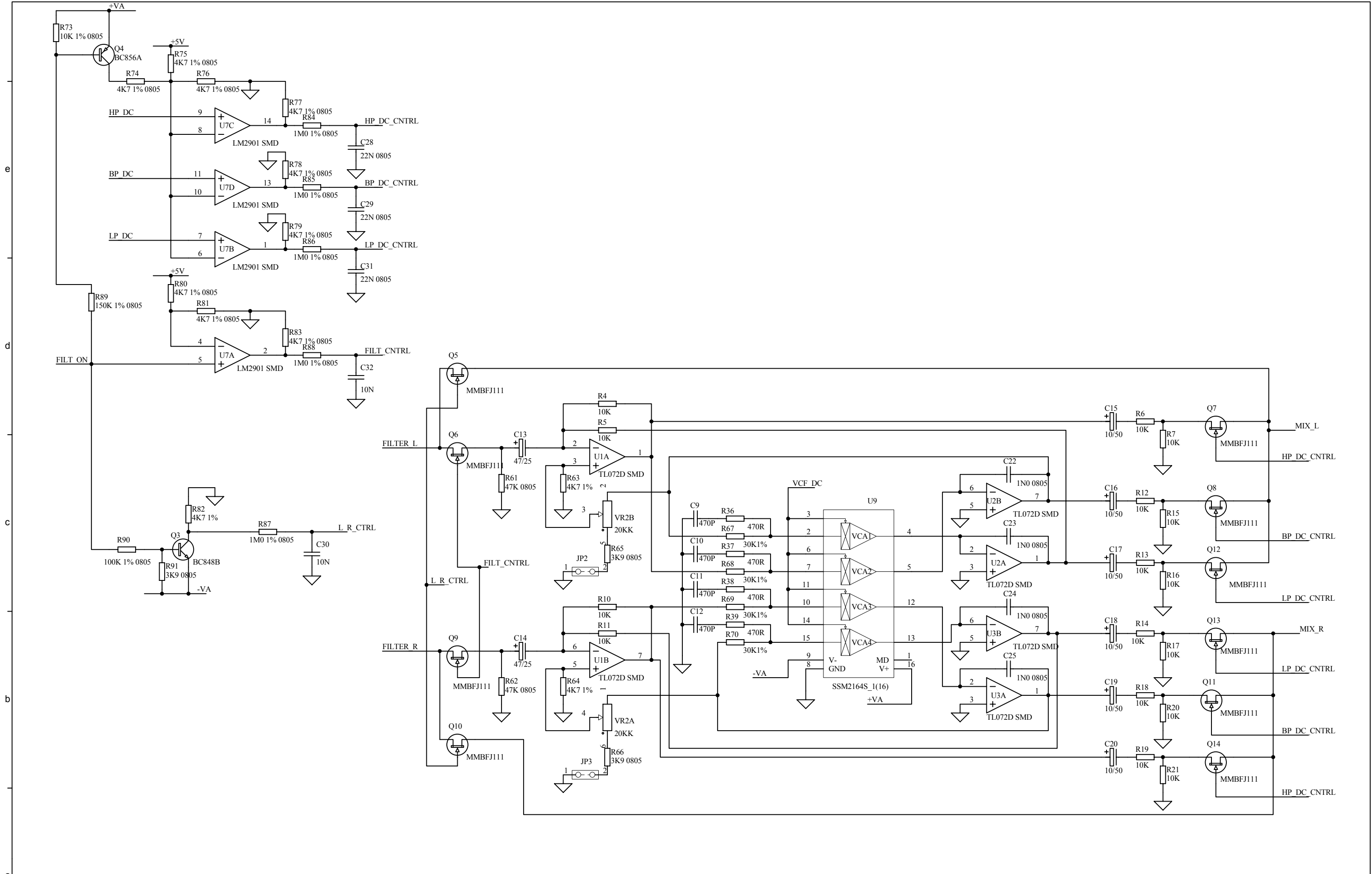

ALLEN&HEATH Kernick Industrial Estate, Penryn, Cornwall, England. TR10 9LU Tel: +44 (0)8707 556250 Fax: +44 (0)8707 556251	ISSUE	BY	DATE	CHK BY
	1	ARJ	07-11-03	
	2	ARJ	18-12-03	

FILE: AG5300 ISS 2 SHEET 2.SCH
 PRINTED: 16:15:57 12-Feb-2004

TITLE: XONE 92 FILTER/MIDI PCB
 PAGE:
 DRG No: C5300 ISSUE: 2 SHEET: 2 OF 3

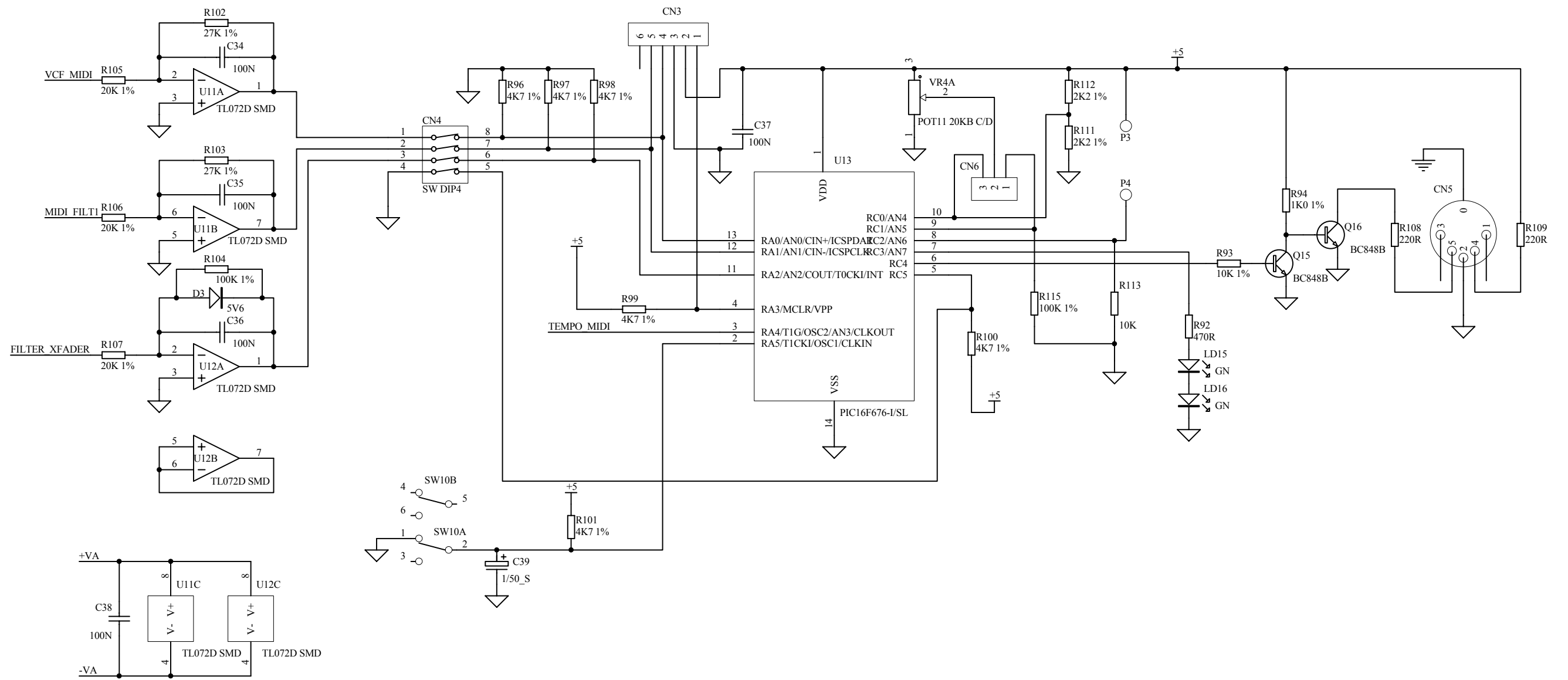

ALLEN&HEATH
 Kernick Industrial Estate,
 Penryn, Cornwall,
 England. TR10 9LU
 Tel: +44 (0)8707 556250
 Fax: +44 (0)8707 556251

ISSUE	BY	DATE	CHK BY
1	ARJ	07-11-03	
2	ARJ	18-12-03	

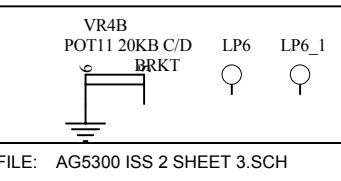

FILE: AG5300 ISS 2 SHEET 3.SCH

PRINTED: 16:15:57 12-Feb-2004

TITLE: XONE 92 MIDI
 PAGE:
 DRG No: C5300 ISSUE: 2 SHEET: 3 OF 3

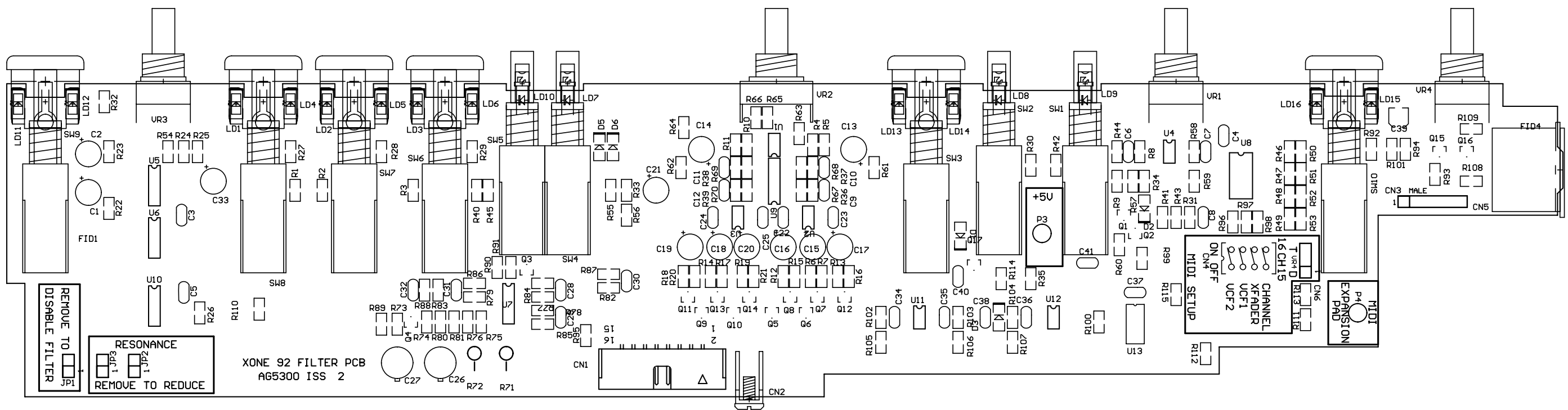

FILTER SWITCH LOGIC

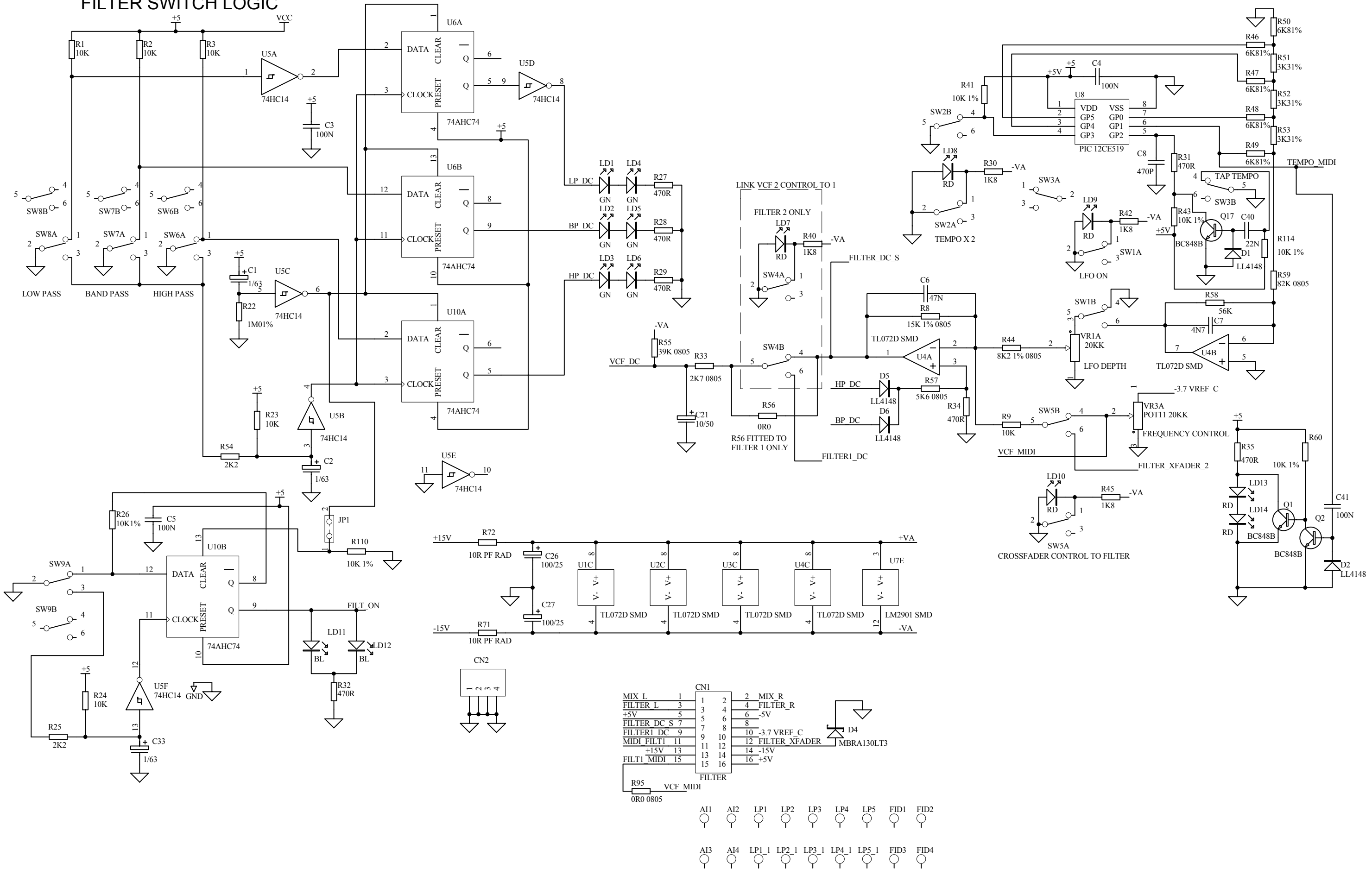

ALLEN&HEATH
 Kernick Industrial Estate,
 Penryn, Cornwall,
 England. TR10 9LU
 Tel: +44 (0)8707 556250
 Fax: +44 (0)8707 556251

ISSUE	BY	DATE	CHK BY
1	ARJ	07-11-03	
2	ARJ	18-12-03	
3	ARJ	11-02-04	

BRKT	BRKT	BRKT
VR2C	VR1B	VR3B
POT14 20KK X2	POT11 20KK	POT11 20KK

FILE: AG5300 ISS 3 SHEET 1.SCH

PRINTED: 10:13:22 21-Sep-2004

TITLE: XONE 92 FILTER/MIDI PCB
 PAGE:
 DRG No: C5300 ISSUE: 3 SHEET: 1 OF 3

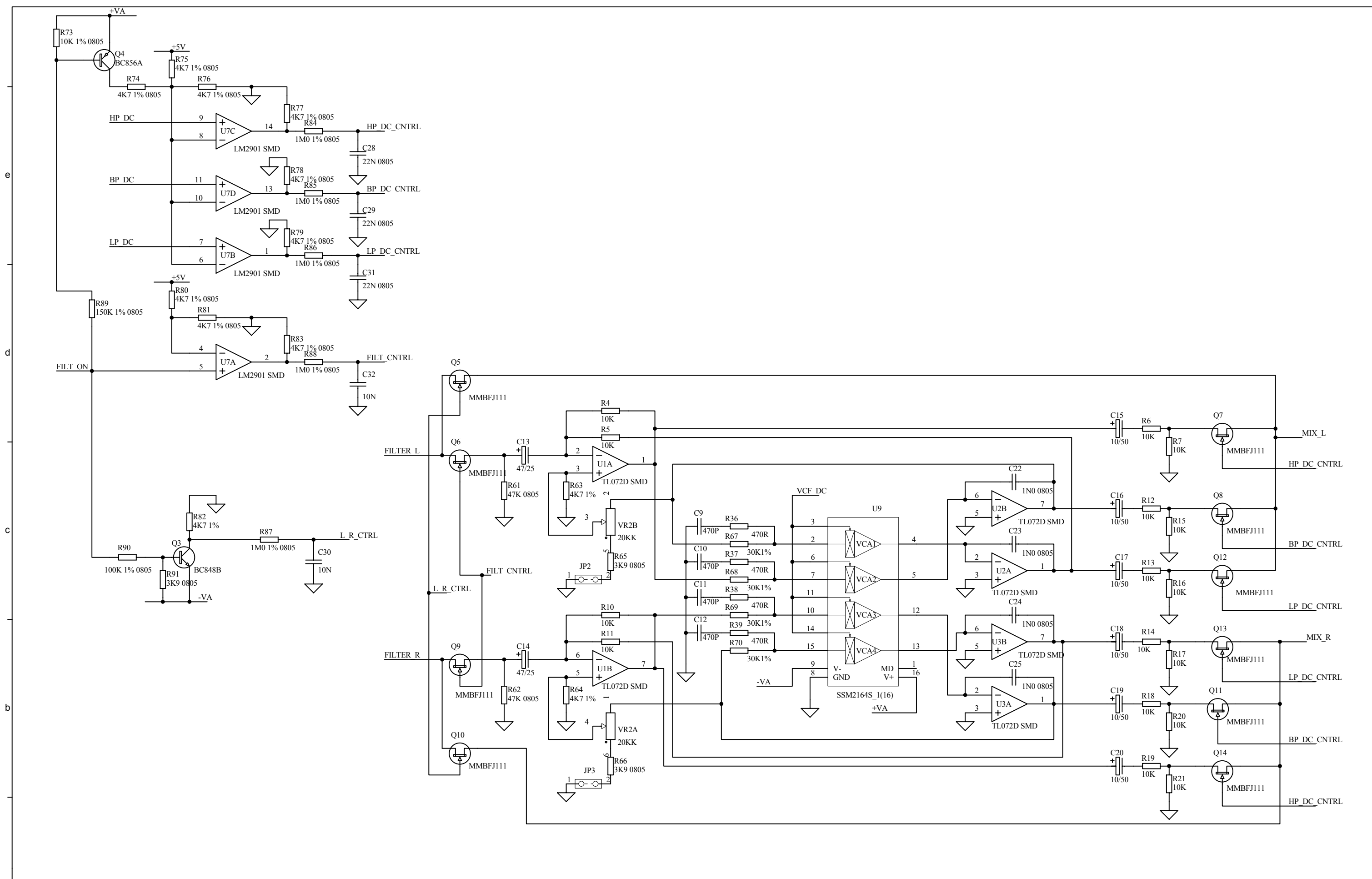

ALLEN&HEATH Kernick Industrial Estate, Penryn, Cornwall, England. TR10 9LU Tel: +44 (0)8707 556250 Fax: +44 (0)8707 556251	ISSUE	BY	DATE	CHK BY
	1	ARJ	07-11-03	
	2	ARJ	18-12-03	
	3	ARJ	11-02-04	

FILE: AG5300 ISS 3 SHEET 2.SCH

PRINTED: 10:13:23 21-Sep-2004

TITLE: XONE 92 FILTER/MIDI PCB
 PAGE:
 DRG No: C5300 ISSUE: 3 SHEET: 2 OF 3

e
d
c
b
a

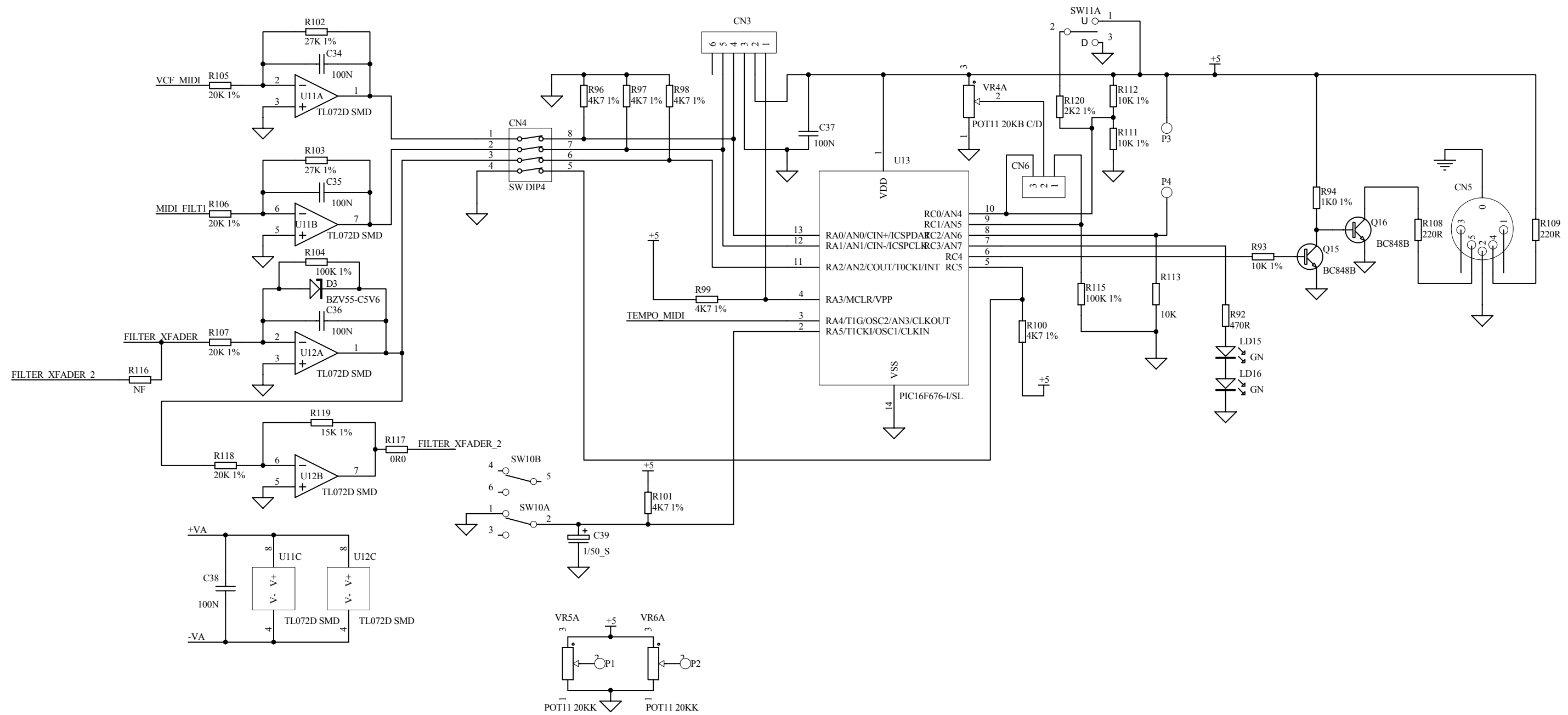

ALLEN&HEATH
 Kernick Industrial Estate,
 Penryn, Cornwall,
 England. TR10 9LU
 Tel: +44 (0)8707 556250
 Fax: +44 (0)8707 556251

ISSUE	BY	DATE	CHK BY
1	ARJ	07-11-03	
2	ARJ	18-12-03	
3	ARJ	11-02-04	

POT11 20KB C/D
 BRKT
 VR4B
 LP6
 LP6_1
 BRKT
 VR5B
 POT11 20KK
 BRKT
 VR6B
 POT11 20KK
 AI5 HOLE-AI
 AI6 HOLE-AI

FILE: AG5300 ISS 3 SHEET 3.SCH

TITLE: XONE 92 MIDI
 PAGE:
 DRG No: C5300 ISSUE: 3 SHEET: 3 OF 3

PRINTED: 10:13:23 21-Sep-2004

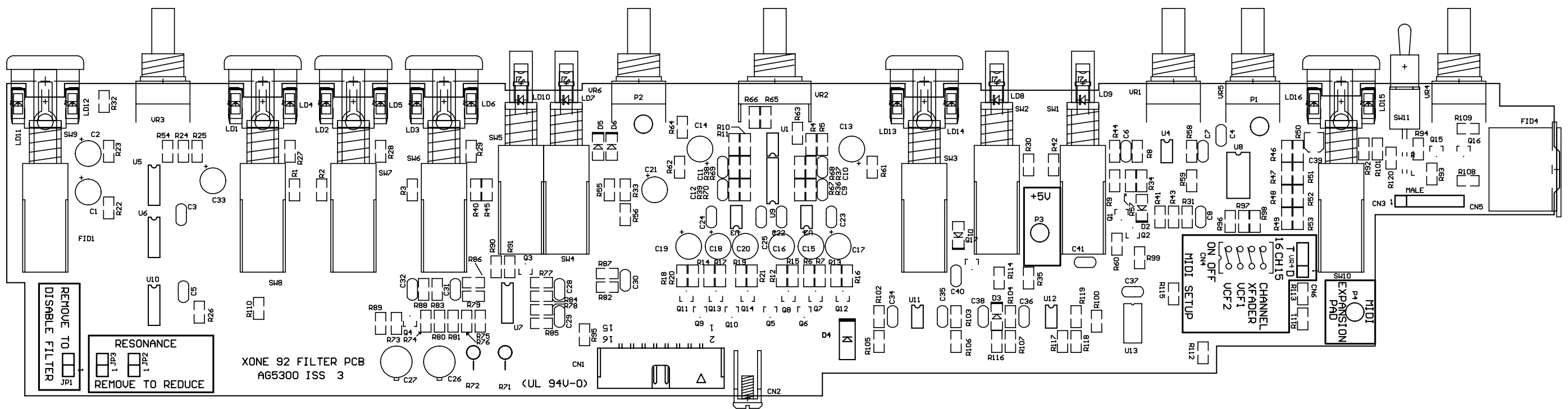

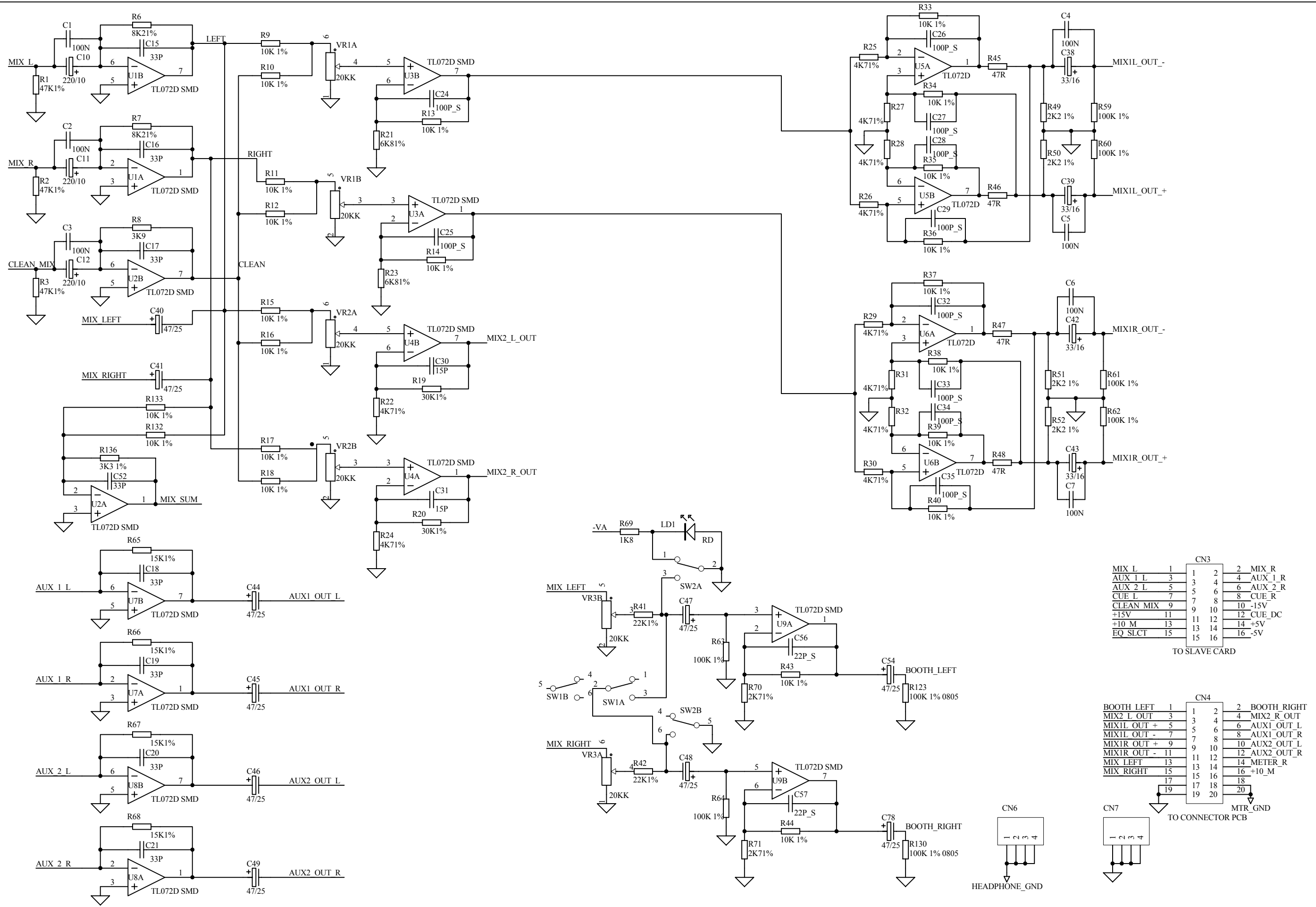

CN3

MIX L	1	2	MIX R
AUX 1 L	3	4	AUX 1 R
AUX 2 L	5	6	AUX 2 R
CUE L	7	8	CUE R
CLEAN MIX	9	10	-15V
+15V	11	12	CUE_DC
+10_M	13	14	+5V
EQ SLCT	15	16	-5V

TO SLAVE CARD

CN4

BOOTH LEFT	1	2	BOOTH RIGHT
MIX2 L OUT	3	4	MIX2 R OUT
MIX1L OUT +	5	6	AUX1 OUT_L
MIX1L OUT -	7	8	AUX1 OUT_R
MIX1R OUT +	9	10	AUX2 OUT_L
MIX1R OUT -	11	12	AUX2 OUT_R
MIX LEFT	13	14	METER_R
MIX RIGHT	15	16	+10_M
	17	18	
	19	20	MTR_GND

TO CONNECTOR PCB

ALLEN&HEATH
 Kernick Industrial Estate,
 Penryn, Cornwall,
 England. TR10 9LU
 Tel: +44 (0)8707 556250
 Fax: +44 (0)8707 556251

ISSUE	BY	DATE	CHK BY
1	ARJ	07-11-03	
2	ARJ	23-03-04	

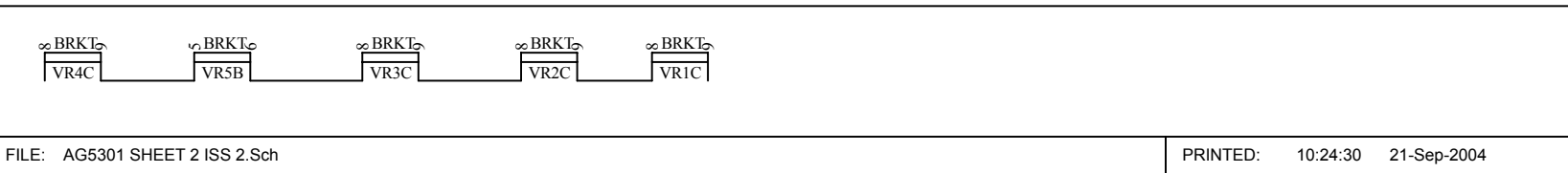

TITLE: **XONE 92 MASTER PCB**
 PAGE:
 DRG No: C5301 ISSUE: 2 SHEET: 1 OF 2

FILE: AG5301 SHEET 2 ISS 2.Sch PRINTED: 10:24:30 21-Sep-2004

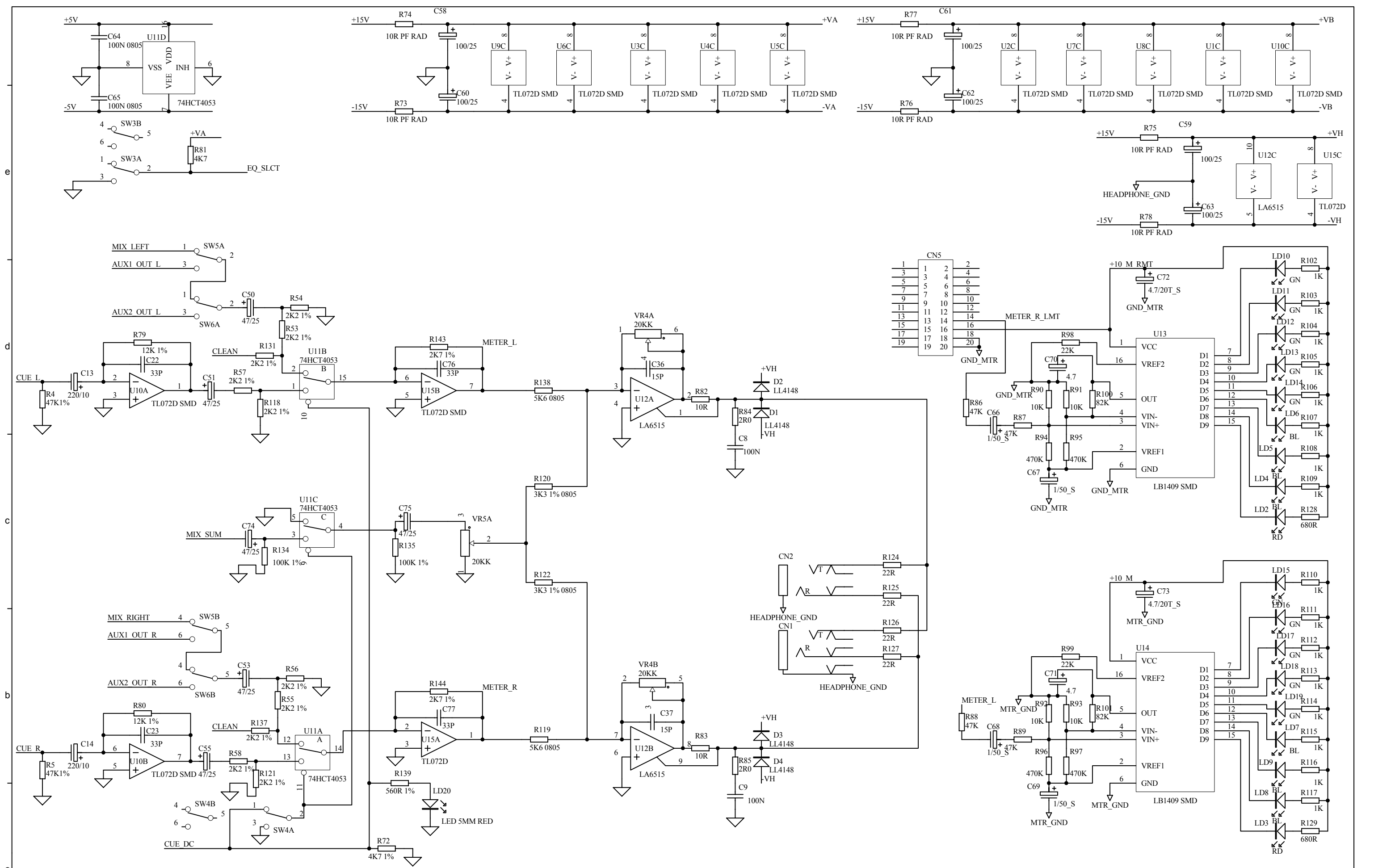

ALLEN&HEATH
 Kernick Industrial Estate,
 Penryn, Cornwall,
 England. TR10 9LU
 Tel: +44 (0)8707 556250
 Fax: +44 (0)8707 556251

ISSUE	BY	DATE	CHK BY
1	ARJ	07-11-03	
2	ARJ	23-03-04	

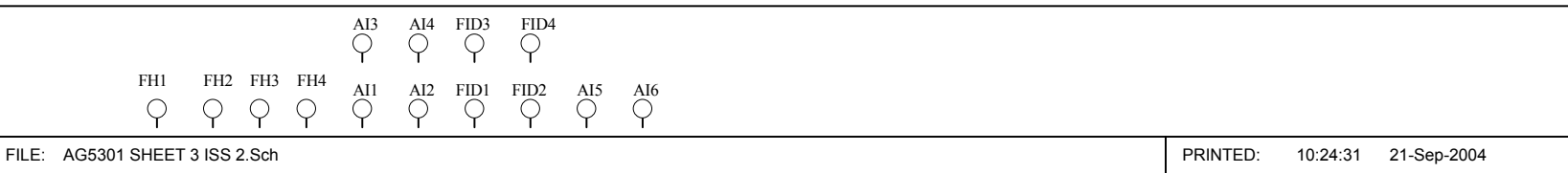

TITLE: XONE 92 MASTER PCB
 PAGE:
 FILE: AG5301 SHEET 3 ISS 2.Sch
 PRINTED: 10:24:31 21-Sep-2004
 DRG No: C5301 ISSUE: 2 SHEET: 2 OF 2

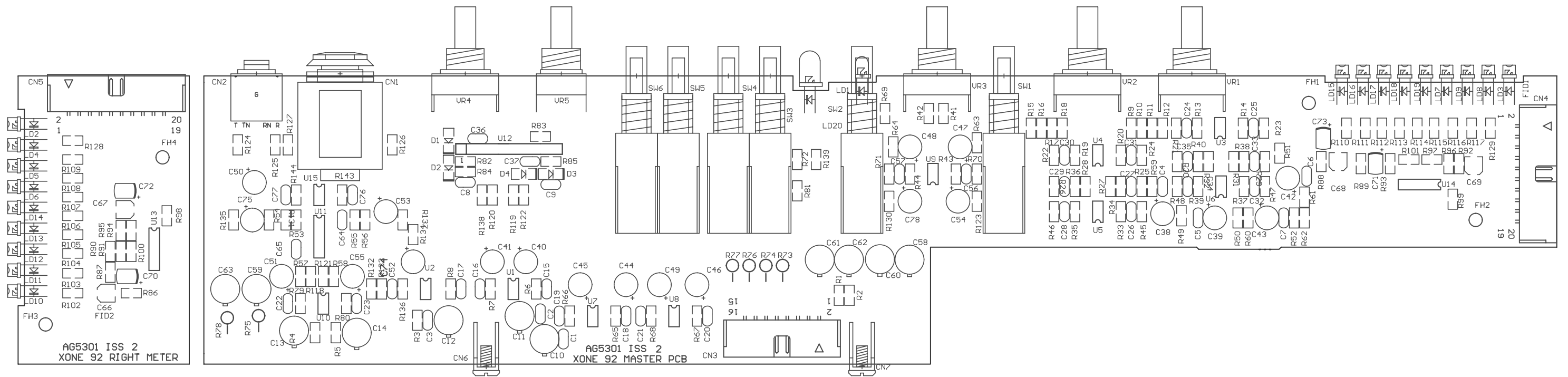

CROSSFADER PCB

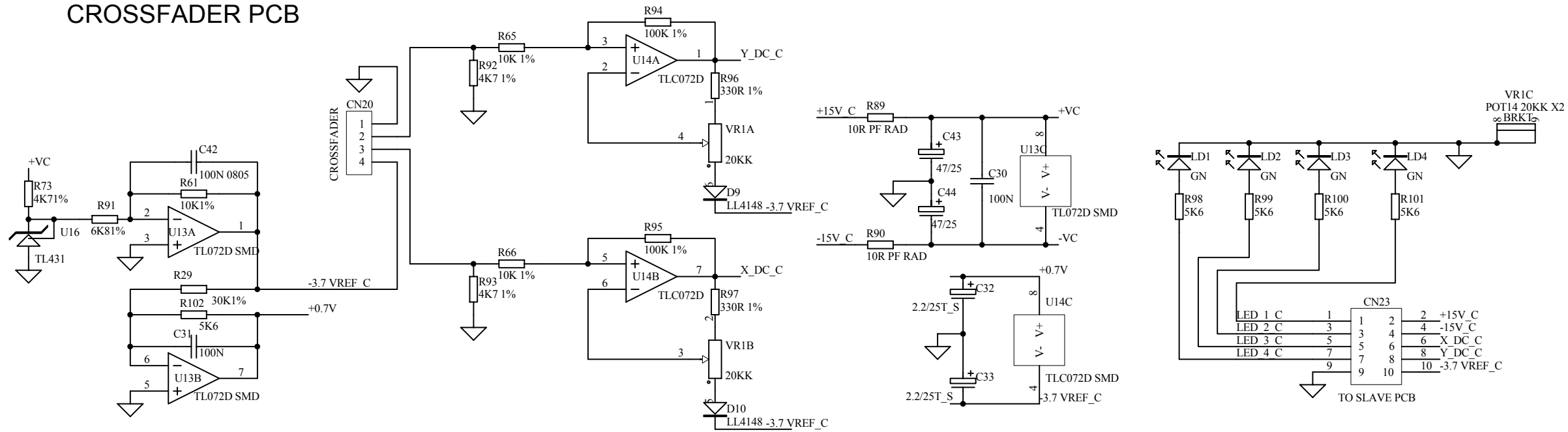

ALLEN&HEATH
 Kernick Industrial Estate,
 Penryn, Cornwall,
 England. TR10 9LU
 Tel: +44 (0)8707 556250
 Fax: +44 (0)8707 556251

ISSUE	BY	DATE	CHK BY
1	ARJ	07-11-03	
2	ARJ	04-05-04	

A11	A12	FID1	FID2	FH12	FH13	FH14
○	○	○	○	○	○	○

FILE: AG5608 CROSSFADER PCB ISS 2.SCH

TITLE:	XONE 92 CROSSFADER PCB		
PAGE:			
DRG No:	C5608	ISSUE:	2
SHEET:	1 OF 1		

PRINTED: 10:43:22 21-Sep-2004

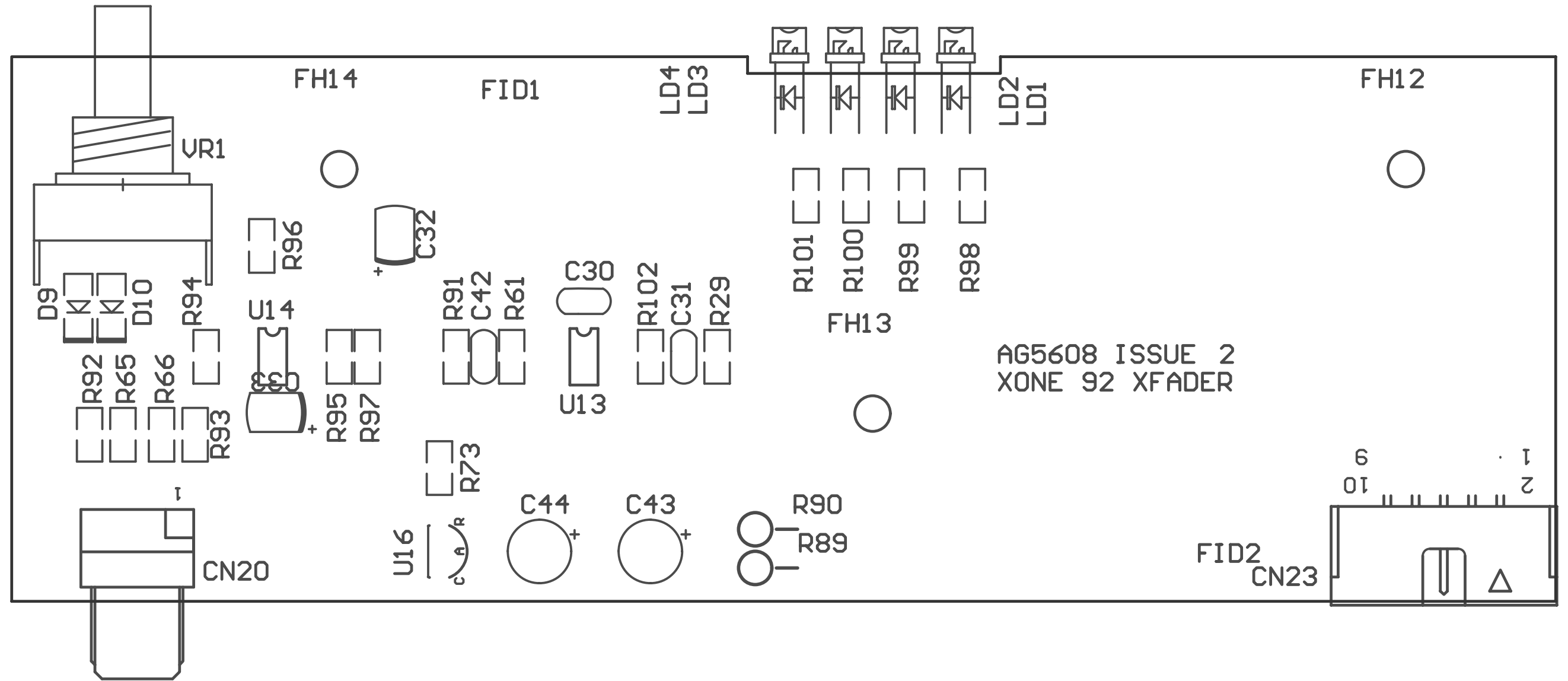

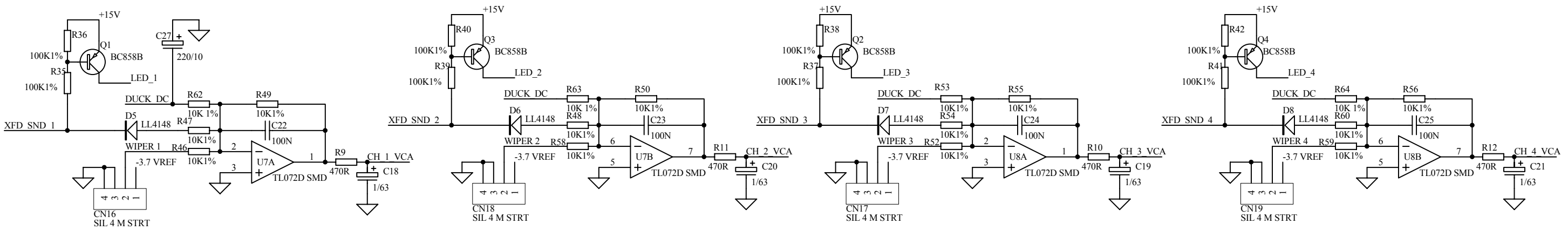
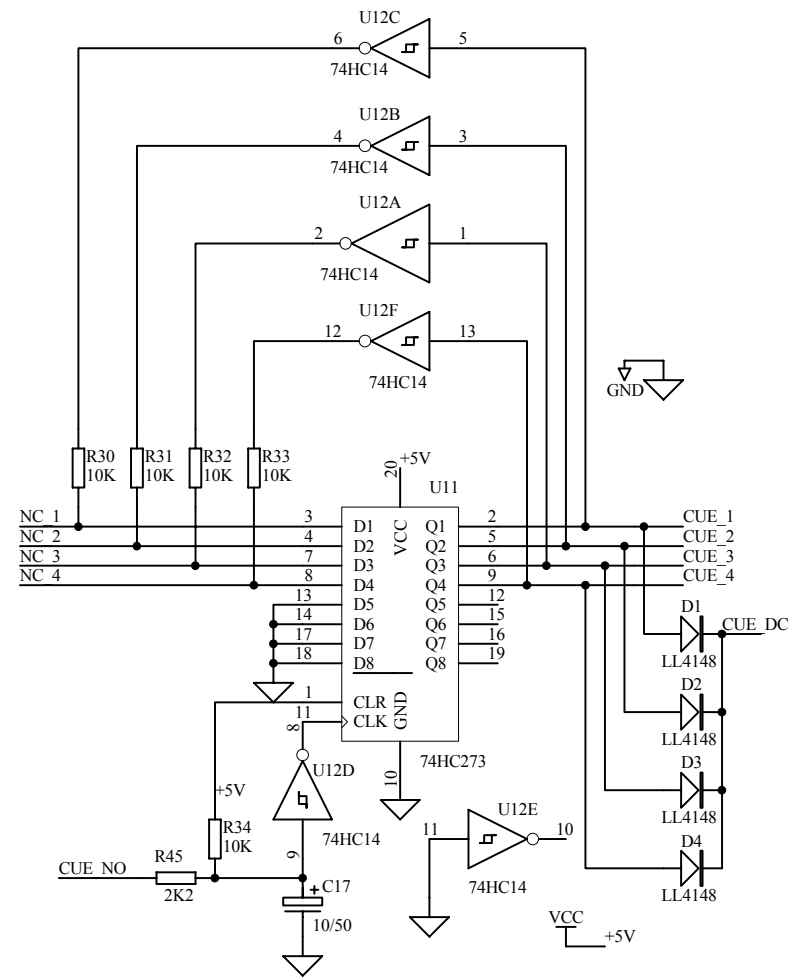
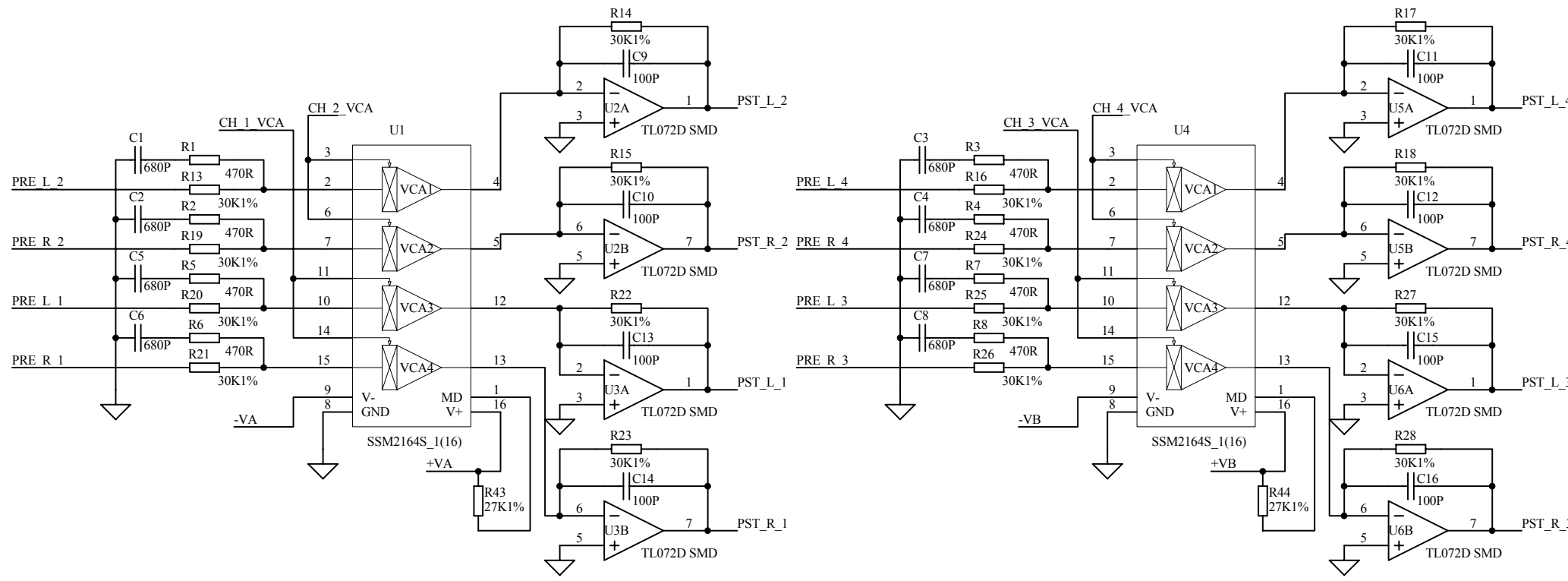
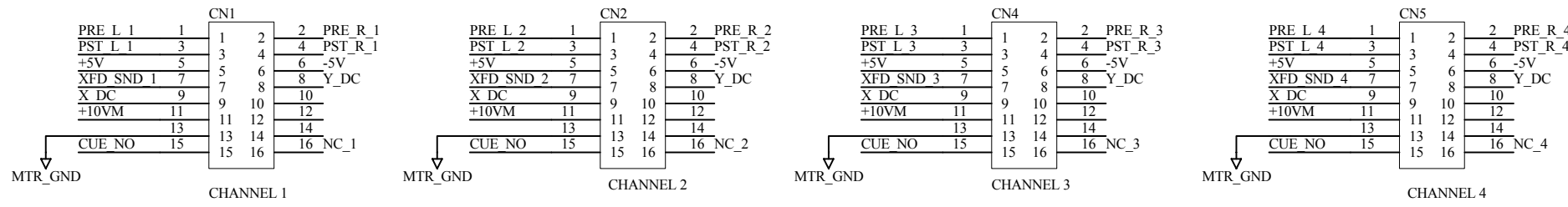

ALLEN&HEATH
 Kernick Industrial Estate,
 Penryn, Cornwall,
 England. TR10 9LU
 Tel: +44 (0)8707 556250
 Fax: +44 (0)8707 556251

ISSUE	BY	DATE	CHK BY
1	ARJ	07-11-03	
2	ARJ	30-04-04	

FILE: AG5303 ISS 2 SHEET 2.Sch
 PRINTED: 10:48:27 21-Sep-2004

TITLE: XONE 92 SLAVE CARD
 PAGE:
 DRG No: C5303 ISSUE: 2 SHEET: 1 OF 2

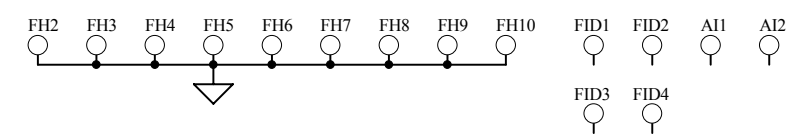
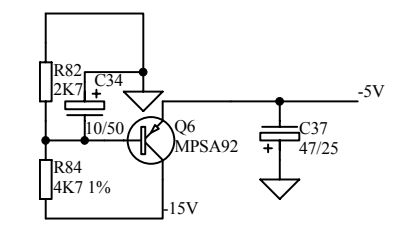
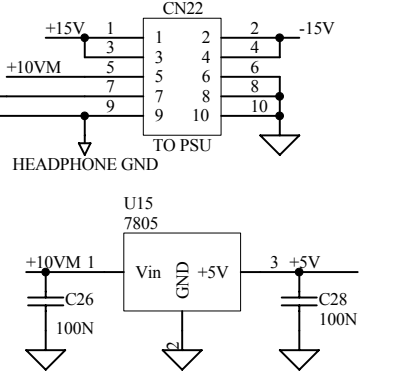
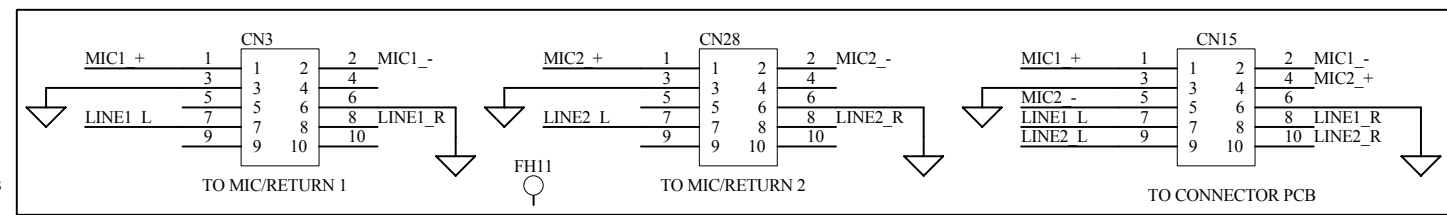
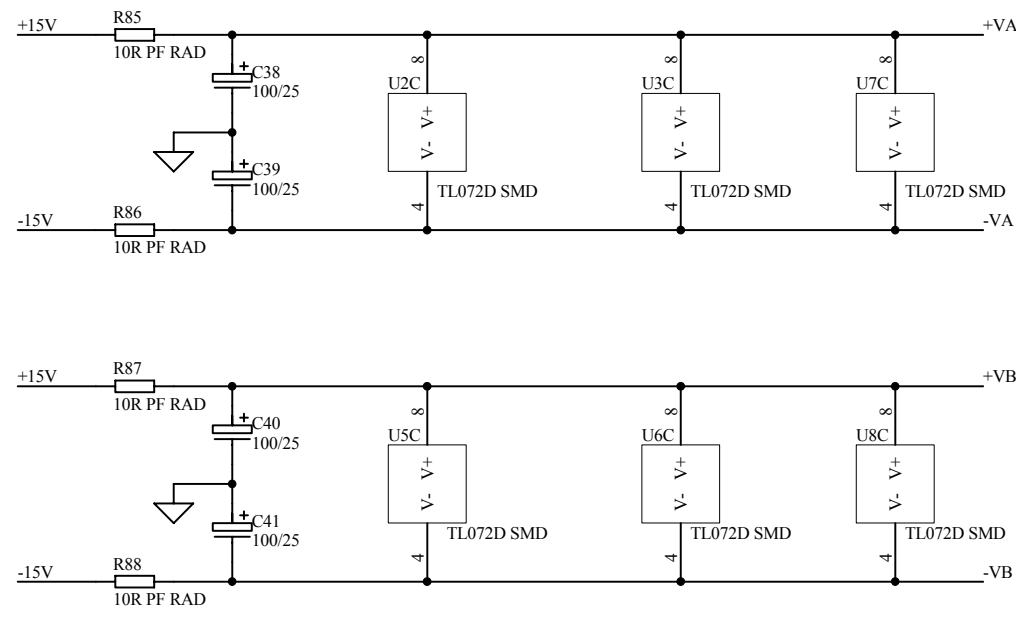
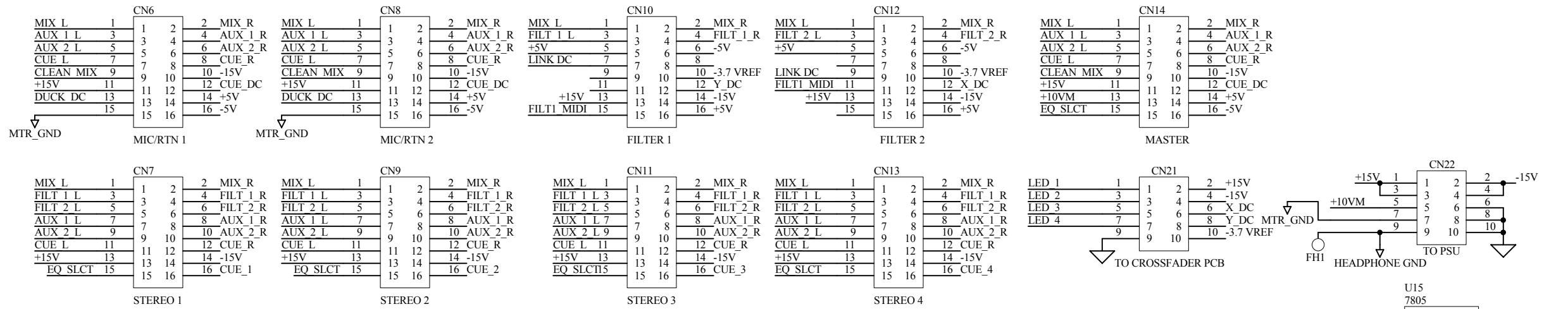

ALLEN&HEATH
 Kernick Industrial Estate,
 Penryn, Cornwall,
 England. TR10 9LU
 Tel: +44 (0)8707 556250
 Fax: +44 (0)8707 556251

ISSUE	BY	DATE	CHK BY
1	ARJ	07-11-03	
2	ARJ	30-04-04	

FILE: AG5303 ISS 2 SHEET 3.Sch

PRINTED: 10:48:28 21-Sep-2004

TITLE: XONE 92 SLAVE CARD

DRG No: C5303 ISSUE: 2 SHEET: 2 OF 2

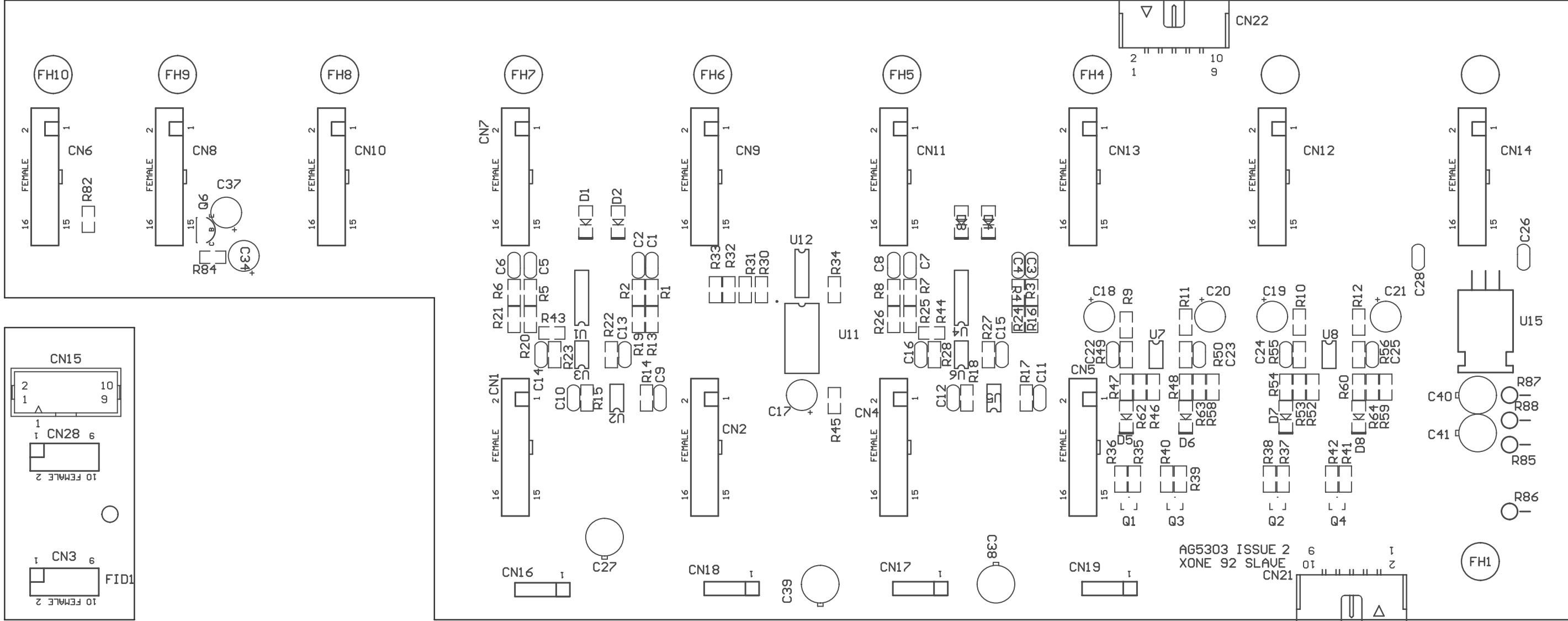

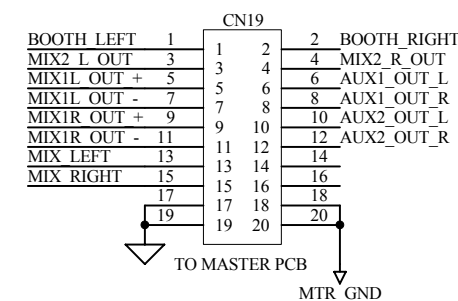
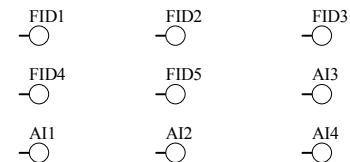
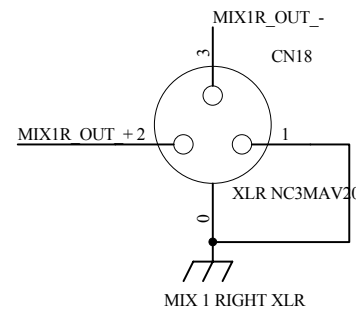
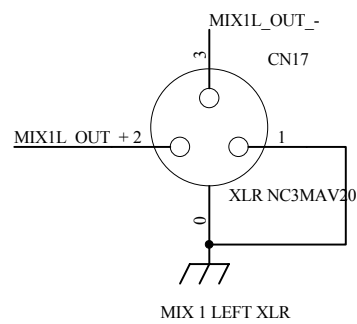
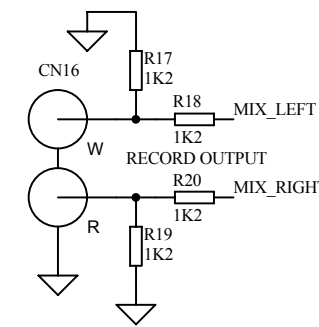
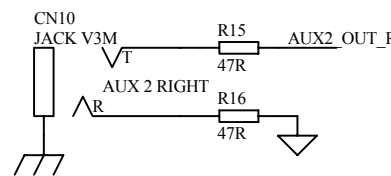
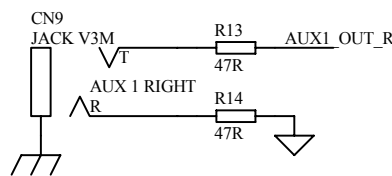
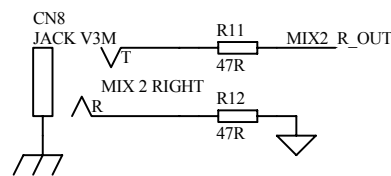
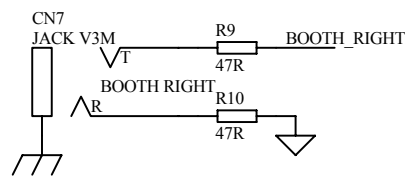
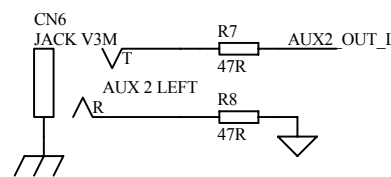
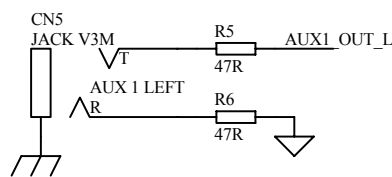
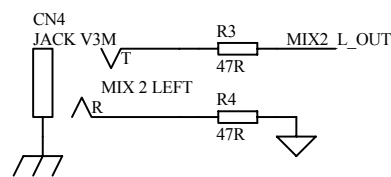
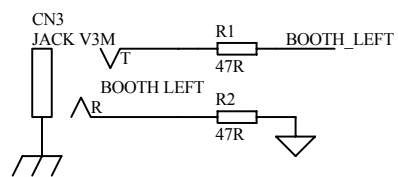
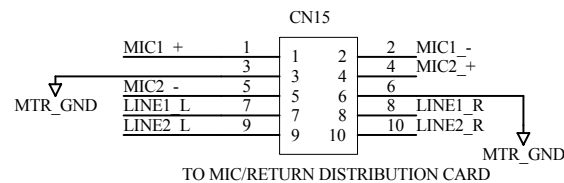
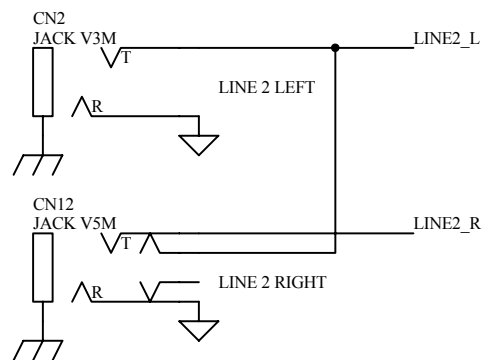
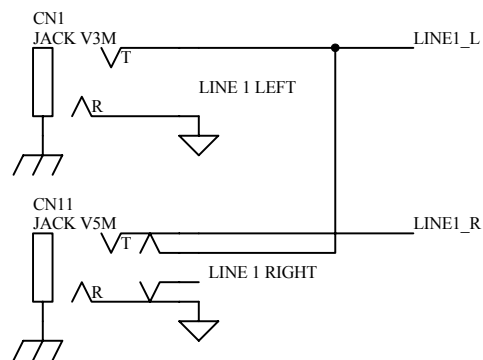
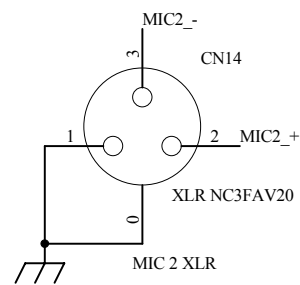
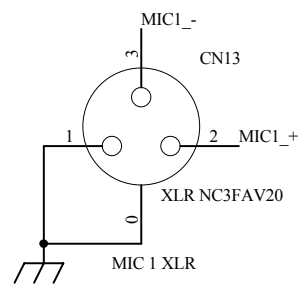

ALLEN&HEATH
 Kernick Industrial Estate,
 Penryn, Cornwall,
 England. TR10 9LU
 Tel: +44 (0)8707 556250
 Fax: +44 (0)8707 556251

ISSUE	BY	DATE	CHK BY
1	JW	18-12-03	

FILE: AG5304 ISS 1.Sch

PRINTED: 12:10:46 21-Sep-2004

TITLE: XONE 92 CONNECTOR PCB

PAGE:

DRG No: C5304 ISSUE: 1 SHEET: 1 OF 1

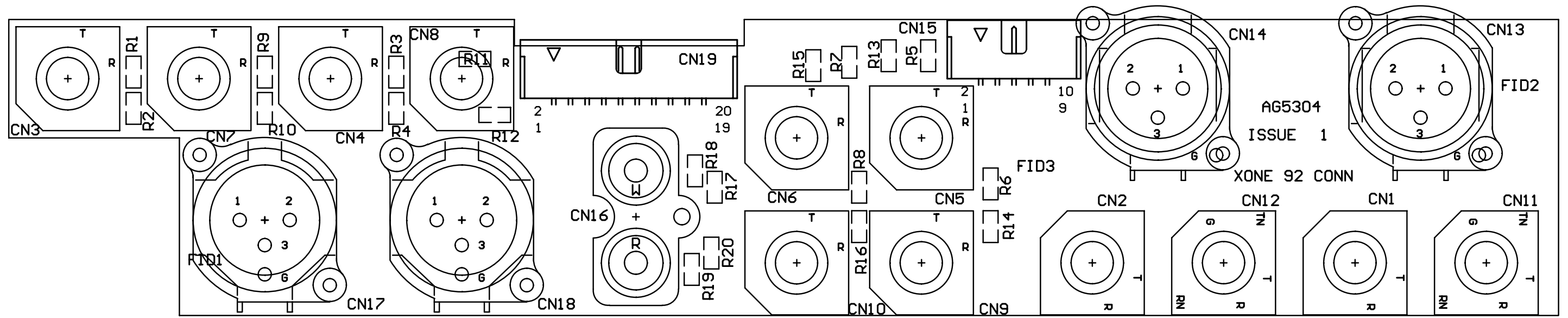

e

d

c

b

a

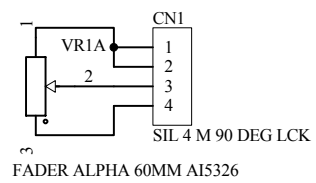

ISSUE	BY	DATE					TITLE: XONE 92 LINEAR FADER PCB		ALLEN&HEATH	
1	ARJ	07-11-03					PAGE:		Kernick Industrial Estate, Penryn, Cornwall, England. TR10 9LU	
FILE: AG5610 LINEAR FADER ISSUE 1.Sch			PRINTED: 11:24:23 21-Sep-2004		DRG No: C5610	ISSUE: 1	SHEET: 1 OF 1	A3	Tel: +44 (0)8707 556250 Fax: +44 (0)8707 556251	

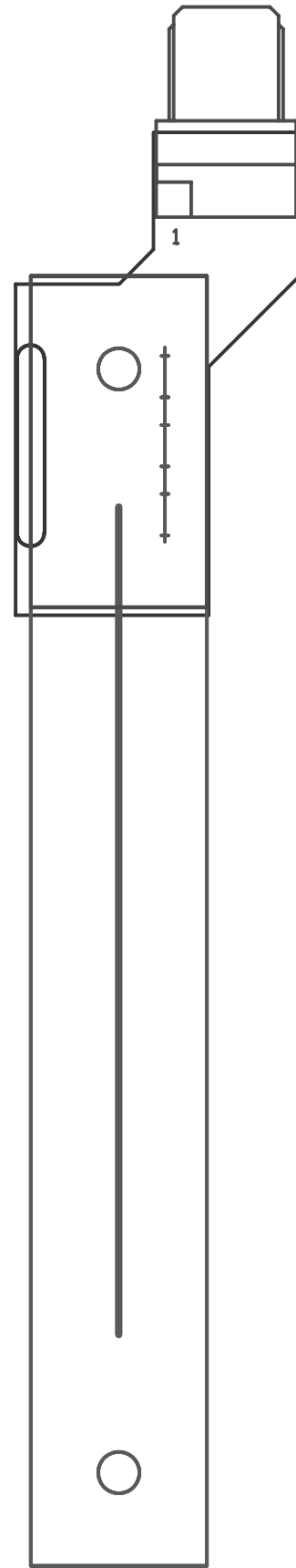

e

d

c

b

a

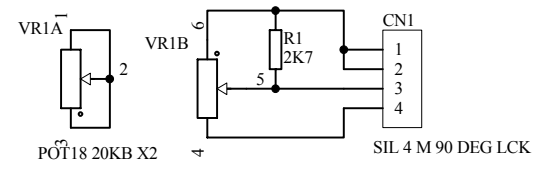

ISSUE	BY	DATE	A11 HOLE-A1		A12 HOLE-A1		TITLE: XONE 92 ROTARY FADER OPTION			
1	ARJ	07-11-03	○		○		PAGE:			
2	ARJ	30-04-04					DRG No: C5611			
FILE: AG5611 ISSUE 2.Sch			PRINTED: 11:12:39 21-Sep-2004			ISSUE: 2		SHEET: 1 OF 1		A3

ALLEN&HEATH
 Kernick Industrial Estate,
 Penryn, Cornwall,
 England. TR10 9LU
 Tel: +44 (0)8707 556250
 Fax: +44 (0)8707 556251

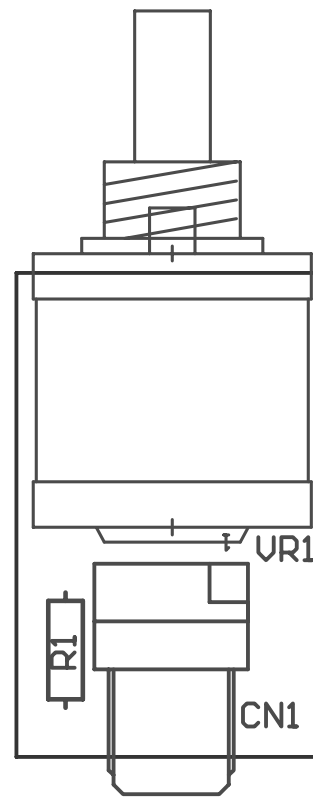

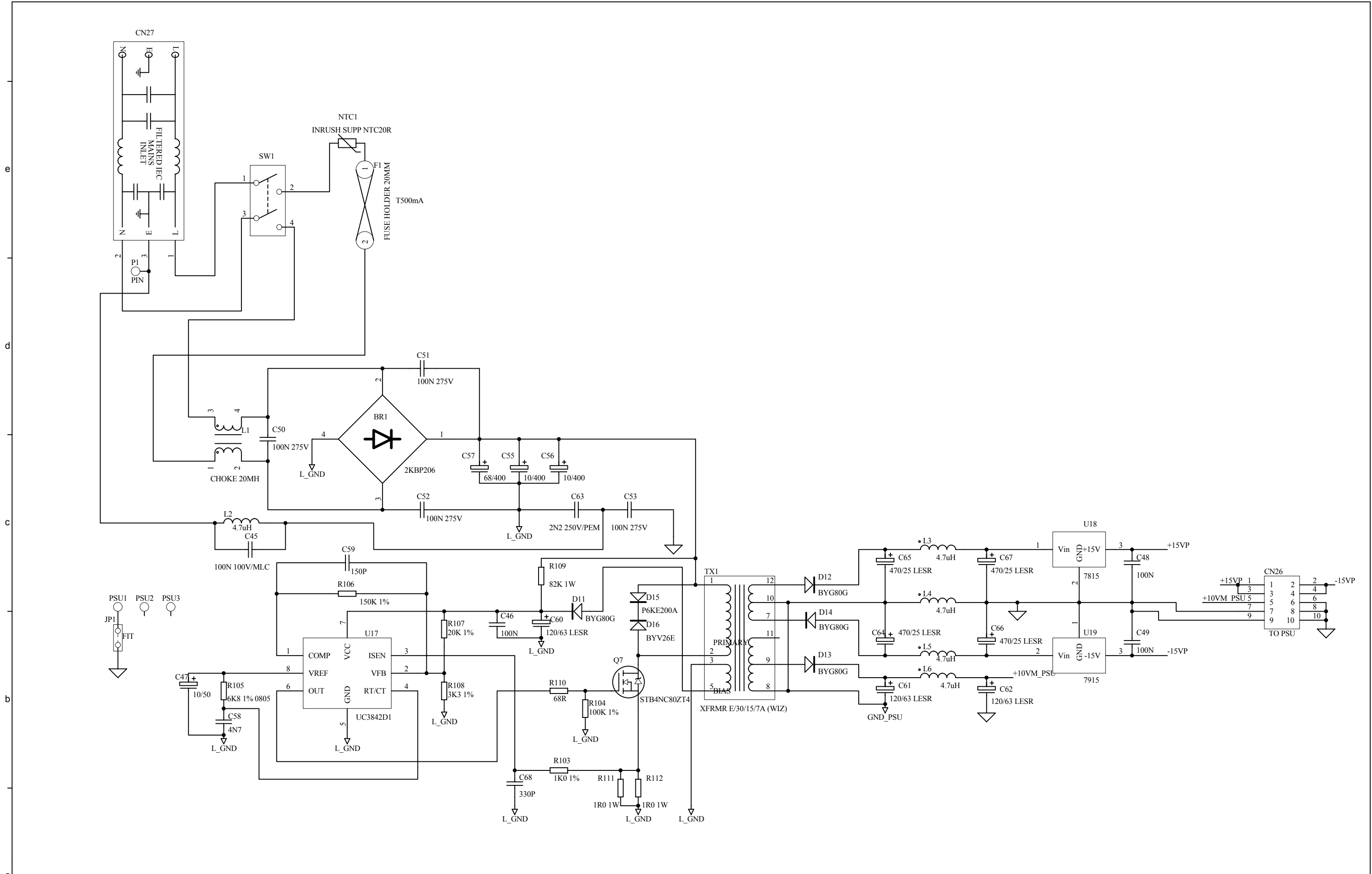

ALLEN&HEATH Kernick Industrial Estate, Penryn, Cornwall, England. TR10 9LU Tel: +44 (0)8707 556250 Fax: +44 (0)8707 556251	ISSUE	BY	DATE	CHK BY	FID1	FID2	FID3	FID4	AI1	AI2	TITLE: XONE 92 POWER SUPPLY
	1	ARJ	07-11-03								PAGE:
	2	ARJ	04-05-04								DRG No: C5609
			SPEA UPDATE								ISSUE: 2
											SHEET: 1 OF 1
											PRINTED: 11:16:55 21-Sep-2004
											FILE: AG5609 PSU_MAINS ISSUE 2.Sch

AG5609 ISSUE 2 XONE 92 PSU

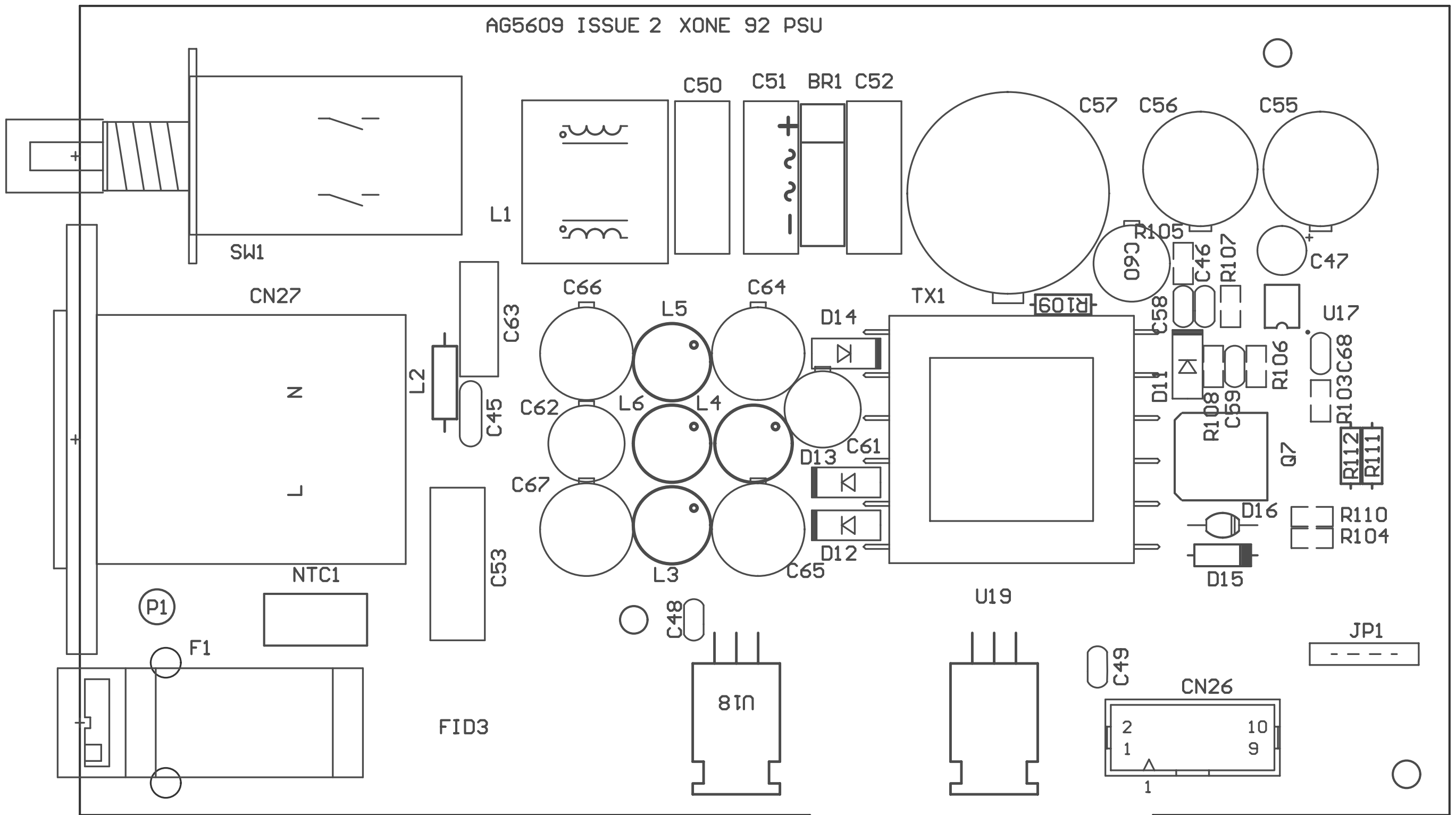

XONE:92 Filter 1 & Filter 2 PCB modification

ECN No: 984
Assembly No(s): 003-138 & 003-143, iss.2
Date: March 11th 2004
Reason: EMC emission reduction

Details of change:

Assy 003-138 & 003-143, PCB AG5300 issue 2
See below

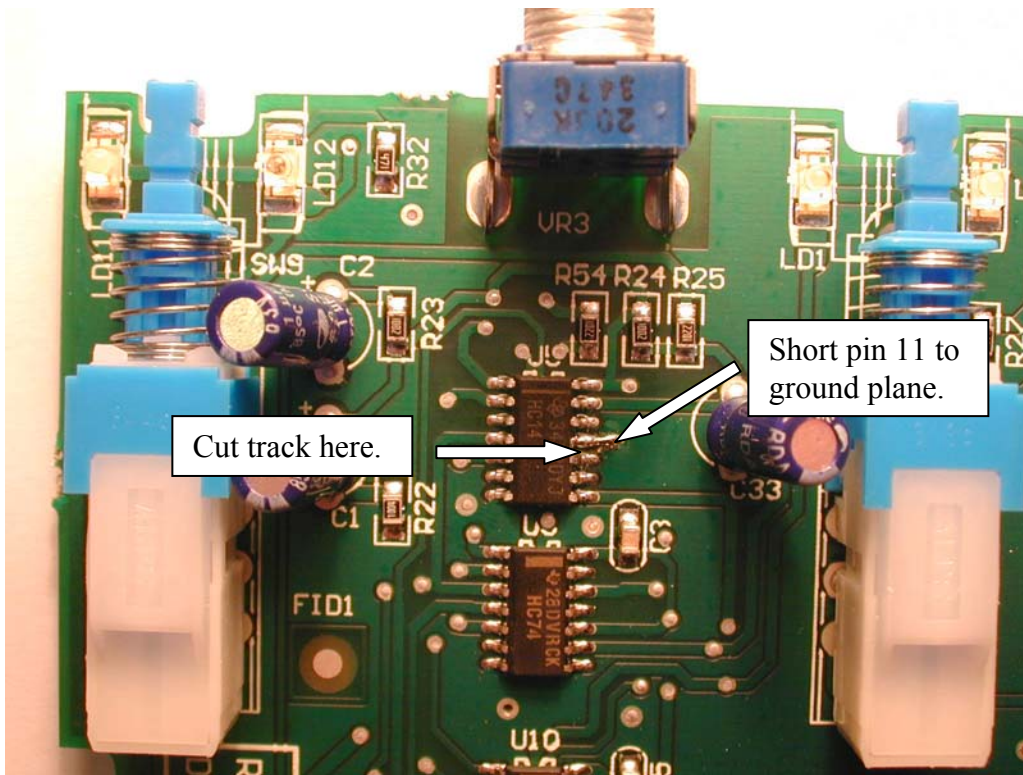

This modification was carried out on issue 2 PCBs from March 11th 2004 until the introduction of the issue 3 PCBs.

XONE:92 Filter value change + diode addition

ECN No: 993
Assembly No(s): 003-138 & 003-143 iss.1 & 003-141 iss.1
Date: March 3rd 2004
Reason: To prevent the filters becoming unstable when all channels are assigned to the crossfader, with filters to crossfader selected, crossfader response on max and resonance on max.

Details of change:

On filter 1 and 2 (AG5300 issue 1) resistor R55 needs to change from 27K to 39K
On the slave card (AG5303) a diode (AE3914) needs to be soldered from pin 12 to ground on both connectors CN10 and CN12

This change was applied to issue 1 PCBs from serial no. 060507 until the introduction of the issue 2 Filter PCBs.

XONE:92 PSU IEC Mains Filter with Nutserts

ECN No: 998
Assembly No(s): 003-233, Issue 1 on
Date: March 29th 2004
Reason: To improve assembly of IEC to Chassis.

Details of change:

The IEC Mains Filter AL3458 now has nutserts, eliminating the need to fit two nyloc nuts (AB0102), and two screws (AB0078).

The new screws required are AB5564 x 2 (under head pips):

This change was applied to issue 1 PCBs onwards from March 2004.

XONE:92 Master PCB output level change

ECN No: 1018
Assembly No(s): 003-139, Issue 1
Date: May 14th 2004
Reason: Output level increase

Details of change:

RESISTOR VALUE CHANGES Assy 003-139, PCB AG5301 iss.1
Change R25 to R32 inclusive from AC5017 (8K2) to AC3062 (4K7)
R19, R20 from AC5036 (10K) to AC5628 (30K)
R22, R24 from AC4754 (6K8) to AC5038 (4K7 Melf)
R70, R71 from AC3039 (8K2) to AC5108 (2K7)

These resistor values were fitted on issue 1 PCBs from serial no. 063122 until the introduction of the issue 2 PCBs.

XONE:92 Slave PCB capacitor change

ECN No: 1020
Assembly No(s): 003-141, Issue 1
Date: May 17th 2004
Reason: Easier to select multiple channel cues.

Details of change:

CAPACITOR VALUE CHANGE Assy 003-141, PCB AG5303 iss.1
Change capacitor C17 from 1/63 (AF0210) to 10/50 (AF0214)

This capacitor was fitted to issue 1 PCBs from serial no 063515 until the introduction of the issue 2 PCBs.

ALLEN&HEATH

Parts identification sheet

Xone:92

How to order parts

Parts must be ordered from our distributor in your territory. A list of international distributors can be viewed at <http://www.allen-heath.com/UK/distributors.asp>

UK parts must be ordered through an appointed A&H dealer or service centre. A list of UK service centres can be viewed at http://www.allen-heath.com/UK/service_centres.asp

Screw AB3818 top panel to chassis SILVER.
 Screw AB3329 top panel to chassis STORM GREY.
 Screw AB3819 fader & x-fader SILVER.
 Screw AB0070 fader & x-fader STORM GREY.





MIC/RTN channel

POTS FADERS & KNOBS:

Knob small black
AJ5386 

Small switch cap
AJ5388 

Large switch cap
AJ4251 

MIC/RTN fader
knob
AJ4310 

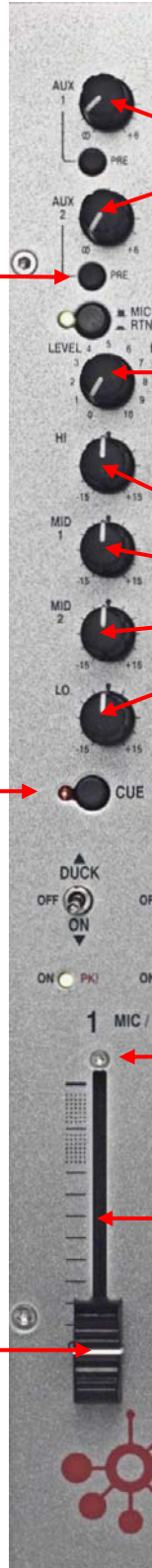

Aux pot
AI8007 

Level pot
AI8007 

EQ
HI, MID1, MID2, LO
AI8006 

Fader screw
AB3329 

MIC/RTN fader
002-684 

Front panel
Silver AA5319
Storm grey
AA7581

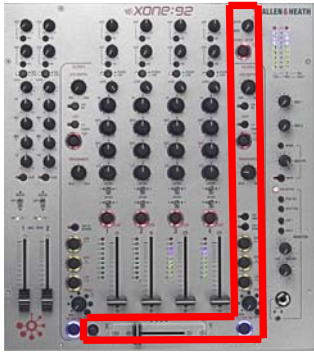

X-fader & filters

Black knob small
AI5386



Black button
AI5325



Black knob large
AI5387



Large switch cap
AJ4251



Xfade curve
very small
black knob
AJ5558





X-fader
002-719





Xone x-fader
knob
AJ4251



Fader plate
storm grey
AA7492



DATA, MIDI
pot
AI8004



LFO DEPTH
pot
AI8003



RESONANCE
pot
AI8007



FREQ pot
AI8003





Stereo channel

Black knob
small
AI5386



Small switch cap
AJ5388



Large switch cap
AJ4251



Black knob
large
AI5387





Aux pot
AI8007



Level pot
AI8006



EQ
HI, MID1, MID2, LO
AI5317



1-2 X-Y
Toggle switch
AI5328



Line fader
003-144



Xone fader knob
AJ5320





Monitor section



Black knob small
AI5386



MIX 1-2
AI8007



Large switch cap
AJ4251



Booth pot
AI8007



Small switch cap
AJ5388



CUE ADD MIX
AI8003



Large headphone socket
AL0328



Headphone level
AI8007



Small headphone socket
AL5323



Phono shorting plug
AL4396

AC inlet
AL3458

MIDI
AL3962

RCA Phono
AL4977

Ground post
AL8106

XLR female
AL2410

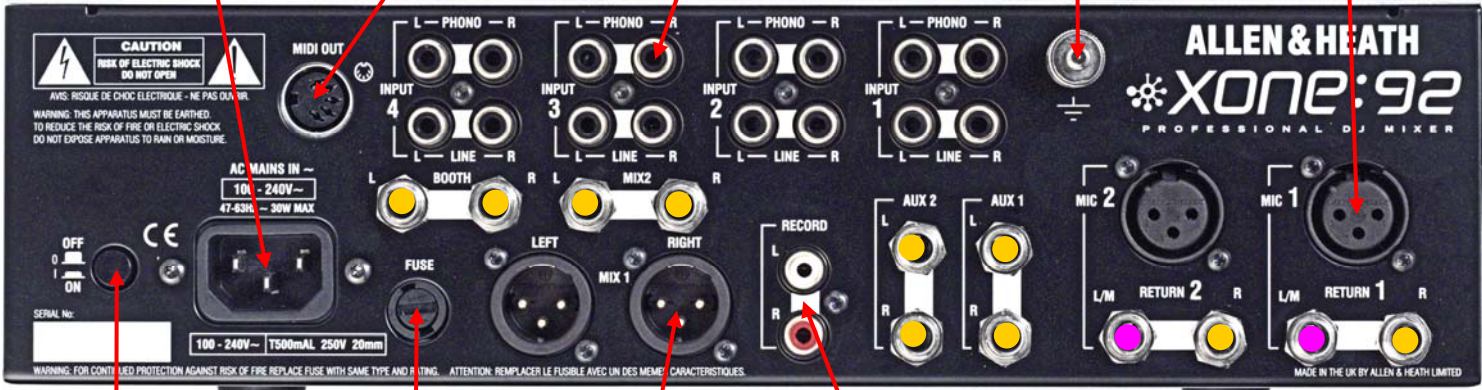

Switch
AL3338

Fuse holder
AL3178

XLR male
AL2411

RCA phono
AL3753

Jack
AL3410

Button
AJ2887

Fuse
AL3534

Jack
AL3407

INTERIOR PARTS:

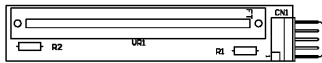

Stereo fader 002-684

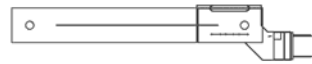

Linear fader 003-144



Rotary fader 003-145 (92R)

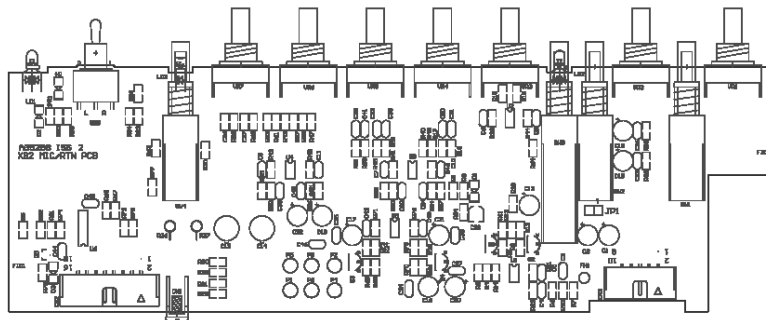

Mic/Stereo Return 003-136

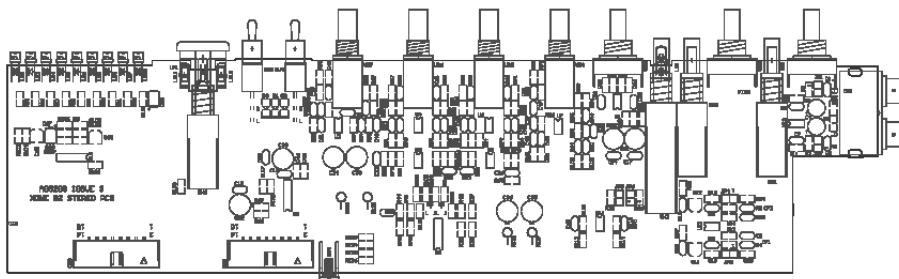

Stereo 003-137

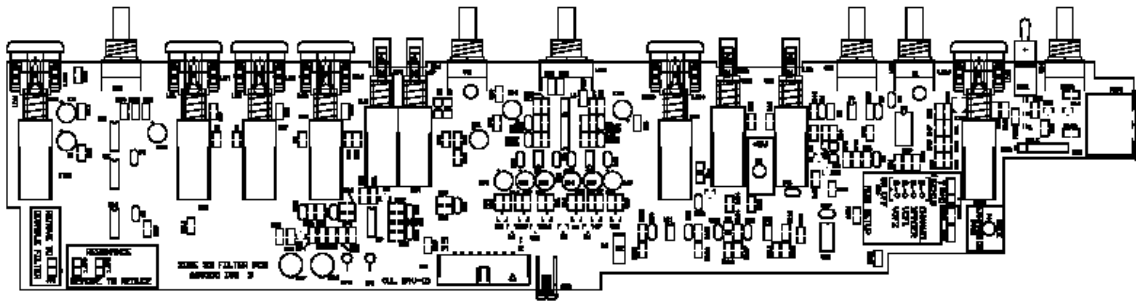

Filter 003-138

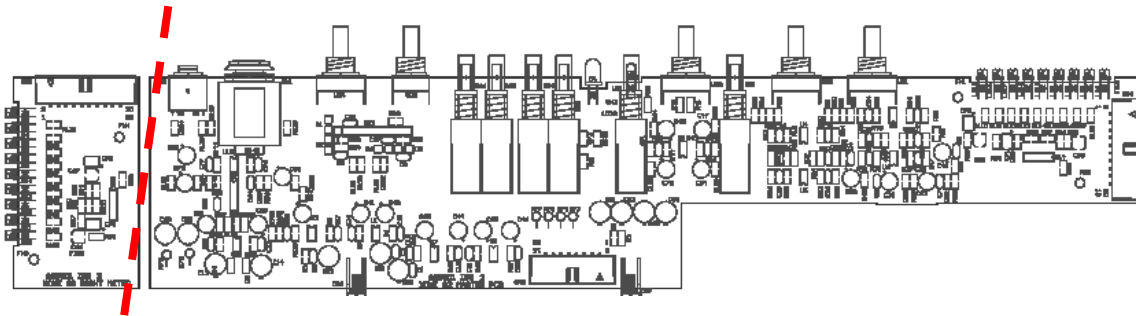

Meter snap-off

Master 003-139

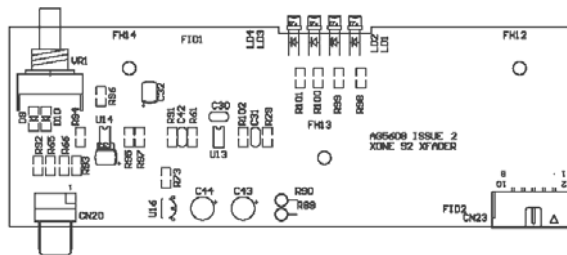

Xfade 003-140

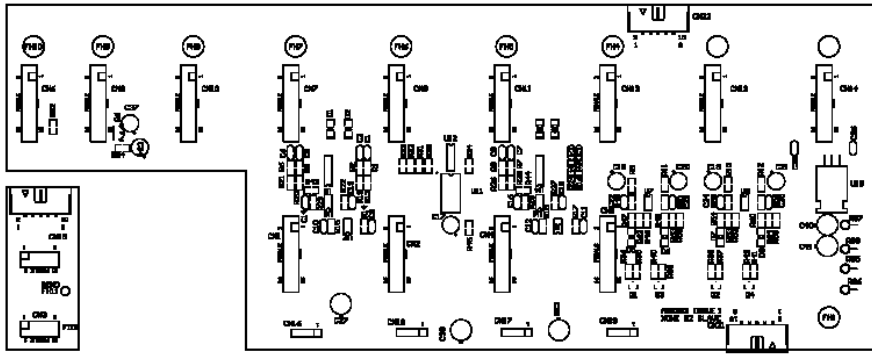

Slave 003-141

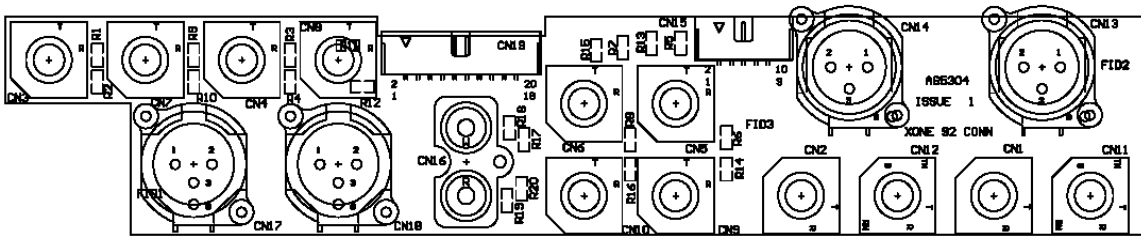

Connector 003-142