

IR Transmitter and Receiver

Description

The IC U2532B is a complete IR-Transmitter-Receiver IC according to the new IrDA 1.0 standard. ASK-modulation is also possible. Only an external PIN-photodiode and an infrared emitting diode with current limiting resistor must be connected to the corresponding pins. The amplifier with Schmitt-Trigger formed output signal and the IR-driver need no further external components. The IC allows data rates from

2.4 kbit/s to 115.2 kbit/s and up to 500 kHz for ASK-modulation. Two different sensitivity modes, which can be programmed by applying a “High” or “Low” voltage at pin SC, ensure either an increase in transmission distance or a bit error rate of $1E-9$. An internal AGC allows proper operation under EMI conditions.

Features

- Data rates up to 115.2 kbit/s
- Wide supply voltage range (3 to 5.5 V)
- AGC for EMI immunity
- AGC reset
- High and low sensitivity mode
- BER < $1E-9$ in the low sensitivity mode
- Power-On reset

Applications

- IR data transmission
- Compatible to IrDA
- Bidirectional IR data transmission
- Ability to receive ASK modulation

Case: SO16

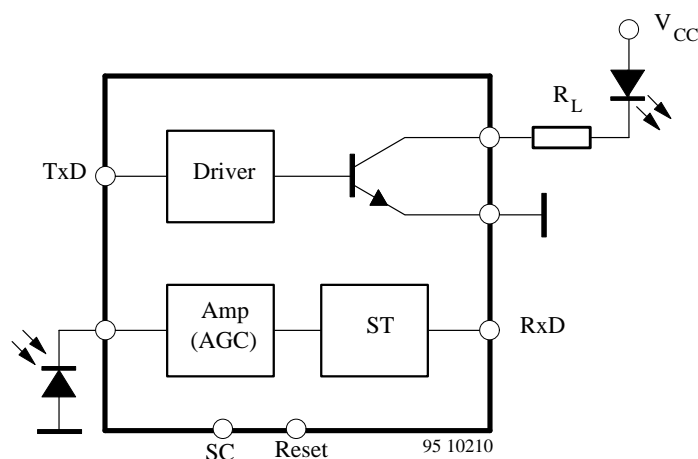
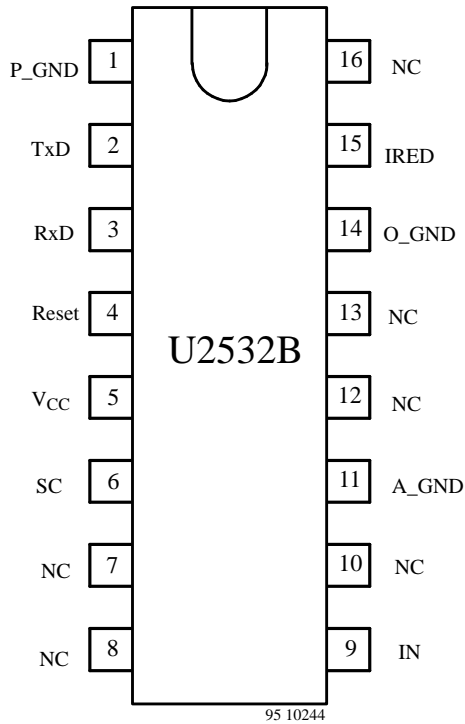

Figure 1.

Pin Description



Pin	Symbol	Function
1	P_GND	Power ground
2	TxD	Transmitter input
3	RxD	Receiver output
4	Reset	AGC-Reset
5	V _{CC}	Supply voltage
6	SC	Sensitivity Control
7, 8, 10, 12, 13, 16	NC	Not connected
9	IN	Photodiode input
11	A_GND	Analog ground
14	O_GND	Output ground
15	IRED	IR-Emitter

Figure 2. Pinning

Block Diagram

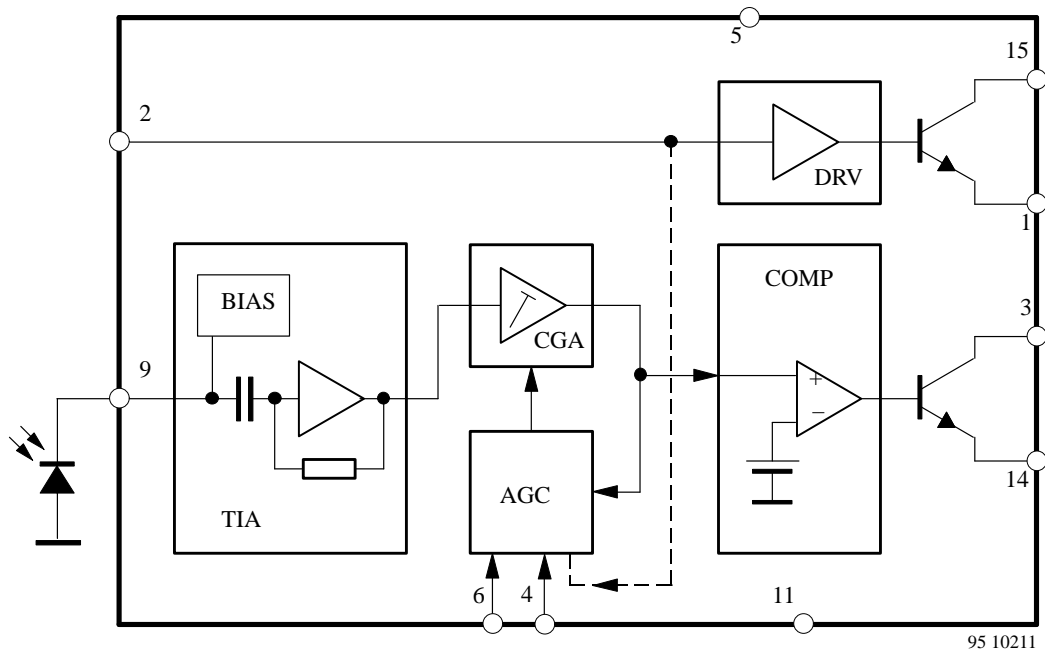

Figure 3. Block diagram

Functionality of the Various Circuit Blocks

Transimpedance Amplifier (TIA)

The input stage provides the necessary bias voltage for the photodiode and ensures decoupling of the useful signal. This involves processing the dc and ac portions in separate parts of the circuit, BIAS (Bias voltage) and TIA. The BIAS circuit separates the dc part (sunlight, incandescent light) from the input signal. The ac portion of the input current is fed to an inverting amplifier with a sufficiently low input impedance (TIA). The TIA prevents the signal slopes to be negatively affected by the junction capacitance of the photodiode.

Controlled Gain Amplifier (CGA)

The CGA consists of two differential amplifiers. The total gain is 17 in the high sense mode (Sensitivity Control Input "High") and can be reduced to 8 if the Sensitivity Control Input is set to "Low". In the low sense mode a BER of $1E-9$ is guaranteed. In the high sense mode eventually generated output pulses must be suppressed by software handling. The lower and upper cut-off frequencies of the amplifier are 25 kHz and 900 kHz respectively. Additionally the overall gain can be attenuated by 30 dB in 2 dB steps. The attenuation is digitally controlled by the AGC (Automatic Gain Control) circuit.

Comparator (COMP)

The comparator compares the output signal of the CGA to an internal threshold voltage. The output of that comparator is directly connected to an collector output stage. An internal pull up resistor of 20 k Ω is provided.

Automatic Gain Control (AGC)

The AGC adjusts the sensitivity of the receiver according to the strength of the incoming signals. When the input signal increases, the amplification of the CGA is reduced

to a value where a BER $< 1E-9$ is still guaranteed, but signals from disturbers can be effectively suppressed. With this feature a proper data transmission can be maintained also in the presence of energy saving lamps and ceiling lamps that are common in offices. The dynamic range of the AGC is max. 30 dB. This provides the ability to suppress also strong disturbers. As the AGC acts when the input signal increases, the transmission distance is reduced if disturbances have to be suppressed. The AGC is digitally controlled and therefore not dependent on any time constant. The amplification of the CGA is set at every input pulse or input burst for ASK-modulation and is maintained until the next input signal is detected. The signal strength determines whether to reduce, increase or maintain the gain. If no input signal is detected in 18 ms, the AGC considers the data transmission to be finished and increases the gain by a 2 dB step. Within every 18 ms the gain is increased by an additional 2 dB step, until the maximum gain of the CGA is reached. If a "High" signal is applied at the reset (Pin 4), the AGC is set to maximum sensitivity. Incoming signals don't influence the AGC. Under this biasing condition it is possible to get maximum transmission distance also in the presence of a known strong disturber, if of course the signals of the disturber can be successfully suppressed by software handling in the microprocessor. During "Power-On" the AGC is set to maximum sensitivity. The gain of the AGC is maintained while the transceiver is transmitting.

Transmitter

IREDDriver (DRV)

The IRED driver DRV is also monolithically integrated on the transceiver chip providing a high impedance input to drive a fast IR emitter diode. The "active high" input signal drives the output stage. This stage mainly consists of an input amplifier and an open collector NPN transistor that is saturation controlled. The output transistor is capable of driving a load current up to 1 A.

Absolute Maximum Ratings

All voltages are referred to A_GND (Pin 11).

Parameters	Test Conditions / Pins	Symbol	Min.	Typ.	Max.	Unit
Supply voltage	Pin 5	V _{CC}	-0.5		6	V
Transmitter input voltage	Pin 2	V _{IN} (TxD)	-0.5		V _{CC} +0.5	V
Sensitivity control voltage	Pin 6	V _{SC}	-0.5		V _{CC} +0.5	V
Reset voltage	Pin 4	V(Reset)	-0.5		V _{CC} +0.5	V
Receiver output voltage	Pin 3	V _O (RxD)	-0.5		V _{CC} +0.5	V
LED driver	Pin 15	V(TxD)	-0.5		6	V
Input currents	Pins 2, 4, 6 and 15				1	mA
Receiver sinking current	Pin 3	I _L (RxD)			10	mA
Photodiode input	Pin 9	V _{IN}	-0.5		V _{CC}	V
Power dissipation		P _{tot}			75	mW
Junction temperature		T _j			150	°C
Ambient temperature range		T _{amb}	-40		125	°C
Storage temperature range		T _{stg}	-40		150	°C
Soldering temperature					230	°C
Average driver current	Pin 15	I _d (DC)			100	mA
Repeated pulsed driver c.	< 90 μs, ton < 20%, Pin 15	I _d (RP)			500	mA
Peak driver current	< 2 μs, ton < 10%, Pin 15	I _d (PK)			1	A

Thermal Resistance

Parameters	Symbol	Value	Unit
Junction ambient	R _{thJA}	180	K/W

Electrical Characteristics

Test conditions: $V_{CC} = 5\text{ V}$, $T_{amb} = 25^\circ\text{C}$, unless otherwise specified

Parameters	Test Conditions / Pins	Symbol	Min.	Typ.	Max.	Unit
Receiver						
Supported data rates			2.4		115.2	kbit/s
Supply voltage range	Pin 5	V_{CC}	3	5	5.5	V
Supply current	Pin 5	IS		1.3	2.5	mA
Sensitivity control voltage “Low”	Low sense mode Pin 6	VSC		0.2	0.5	V
Sensitivity control voltage “High”	High sense mode Pin 6	VSC	2.0	V_{CC}		V
Input threshold current	SC > 0.5 V $V_{CC} = 3\text{ V}$ Pin 9	ilNmin		60	90	nA
Input threshold current	SC > 2.4 V, $V_{CC} = 3\text{ V}$ Pin 9	ilNmin		30	45	nA
Input threshold current for ASK modulation	SC < 0.5 V or open $V_{CC} = 3\text{ V}$ Pin 9	ilNmin (ASK)		200	400	nA
Input threshold current for ASK modulation	SC < 2.4 V or open $V_{CC} = 5\text{ V}$ Pin 9	ilNmin (ASK)		120	250	nA
Max. signal pulse input current	Sensitivity independent Pin 9	ilNmax			6	mA
DC input current	$V_{IN} > 0\text{ V}$ Pin 9	IIN			200	μA
Output voltage RxD	Non active Pin 3	VOH	$V_{CC}-0.5$			V
Output voltage RxD	Active; $I_L = 4\text{ mA}$ Pin 3	VOL		0.2	0.5	V
Rise time	$C = 15\text{ pF}$, $R = 2.2\text{ k}\Omega$ Pin 3	t_r		0.5		μs
Fall time	$C = 15\text{ pF}$, $R = 2.2\text{ k}\Omega$ Pin 3	t_f		0.3		μs
Output pulse width	2.4 kbit/s, 78 μs pulse width Pin 3	t_p		7	15	μs
Output pulse width	115.2 kbit/s, 1.6 μs pulse width Pin 3	t_p		2.5	4	μs
Output delay time	115.2 kbit/s, 1.6 μs pulse width – Output level $0.5 \times V_{CC}$ – Leading edges of signals – Related to optical input Pin 3	t_d		1	2	μs
Jitter	115.2 kbit/s, 1.6 μs pulse width – Period of 10 bits, all “ones” – Leading edges of signals Pin 3	t_j			2	μs
AGC dynamic range	Pin 3			30		dB
AGC single step	Pin 3			2		dB
Max. reset time	15 steps, covering full dynamic range of AGC Pin 3	t_{reset}		270	400	ms

Parameters	Test Conditions / Pins	Symbol	Min.	Typ.	Max.	Unit
Transmitter						
Output voltage IRED "Low"	$I_d = 300\text{mA}$ with appropriate current limiting resistor Pin 15	VOL(TxD)		0.3	0.5	V
Logic "Low" transmitter input voltage	Pin 2	VIN (TxD)		0.4	0.8	V
Logic "High" transmitter input voltage	Pin 2	VIN (TxD)	2	V_{CC}		V
Output leakage current	$V_O(\text{TxD}) = 6\text{ V}$ Pin 15	I_{d0}			10	μA
Output rise time	$I_d = 300\text{ mA}$ Pin 15	t_r			300	ns
Output fall time	$I_d = 300\text{ mA}$ Pin 15	t_f			300	ns
Output pulse width	115.2 kbit/s 1.6 μs pulse width Pin 15	t_p	1.4	1.6	2.7	μs
Overshoot over final current	Pin 15	δI_d			25	%
Jitter	115.2 kbit/s, 1.6 μs pulse width – Period of 10 bits, all "ones" – Leading edges of signals Pin 15	t_j			0.2	μs

Typical Performance Characteristics

Test condition: $V_{CC} = 5\text{ V}$

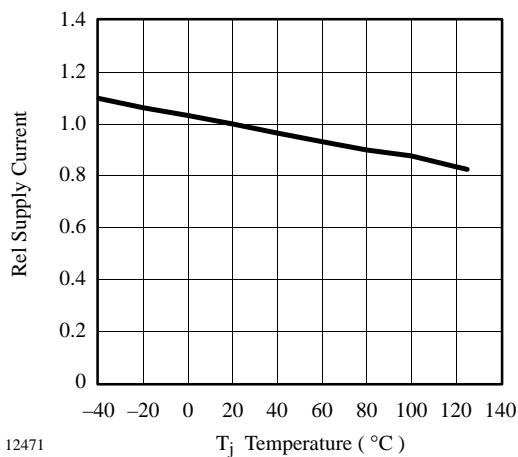

Figure 4. Supply current vs. temperature

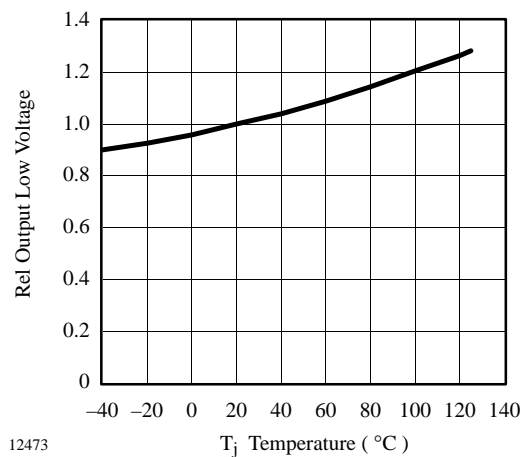

Figure 6. Output voltage IRED "LOW" vs. temperature (transmitter)

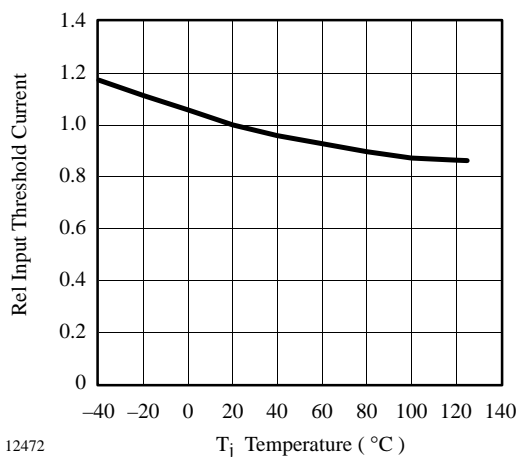

Figure 5. Input threshold current vs. temperature (receiver)

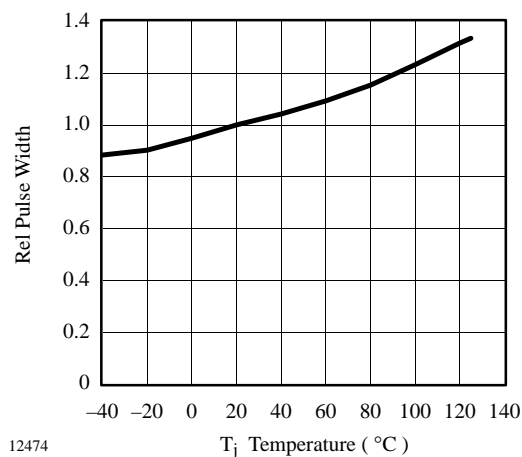

Figure 7. Output pulse width vs. temperature (receiver, 115 kbit/s)

Application Circuit

The diagram below shows the typical application for the IC U2532B. The detector diode and IR emitter can also be obtained from TEMIC. As emitter a high speed infrared emitting diode like TSHF5400 is recommended. For improving output power two diodes can be connected in series. An external current limiting resistor is used to adjust the appropriate forward current. The resulting current of the emitter, with the settings $R_L = 5 \Omega$ and $V_{CC} = 5 \text{ V}$, is $I_d = 300 \text{ mA}$ and the corresponding typical radiant intensity of a single diode is $IE = 120 \text{ mW/sr}$.

The IR radiation detector BPV22NF is a high speed and

high sensitive PIN photodiode in a plastic package with a spherical side view lens. Because of a large radiant sensitive area of $A = 7.5 \text{ mm}^2$ a typical output current of $I_{ra} = 85 \mu\text{A}$ with $E_e = 1 \text{ mW/cm}^2$ and $\lambda = 870 \text{ nm}$ is achieved. A transmitting distance of approximately 3.5 m is possible. R_s and C are the low pass filter network to suppress power supply noise and other disturbances. At pin RxD the output signal can be received. Optionally an external load resistor can be connected from pin 3 to V_{CC} , if a smaller pull up resistor than $20 \text{ k}\Omega$ is desired.

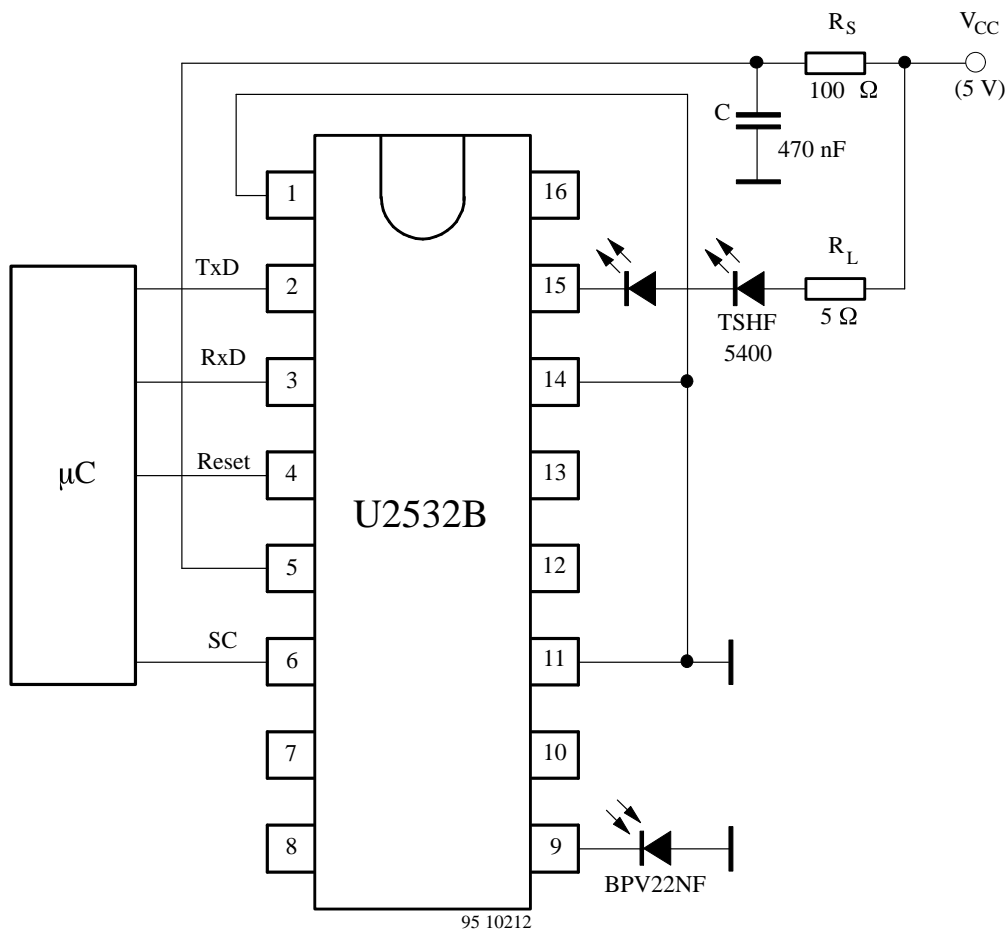

Figure 8.

Dimensions in mm

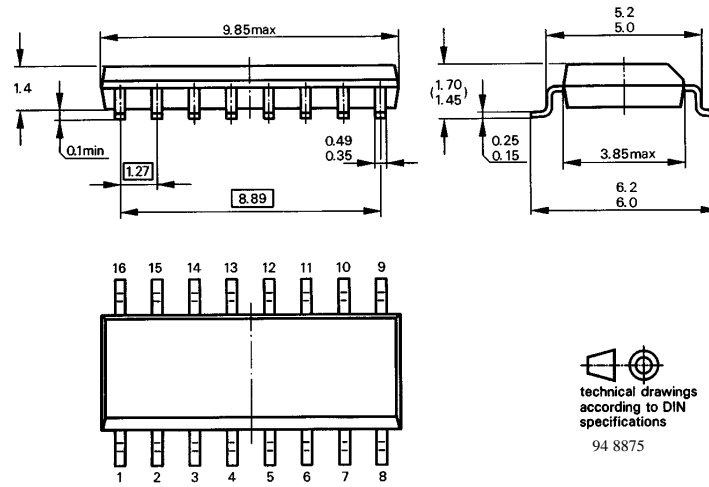

Figure 9.

Ozone Depleting Substances Policy Statement

It is the policy of **TEMIC TELEFUNKEN microelectronic GmbH** to

1. Meet all present and future national and international statutory requirements.
2. Regularly and continuously improve the performance of our products, processes, distribution and operating systems with respect to their impact on the health and safety of our employees and the public, as well as their impact on the environment.

It is particular concern to control or eliminate releases of those substances into the atmosphere which are known as ozone depleting substances (ODSs).

The Montreal Protocol (1987) and its London Amendments (1990) intend to severely restrict the use of ODSs and forbid their use within the next ten years. Various national and international initiatives are pressing for an earlier ban on these substances.

TEMIC TELEFUNKEN microelectronic GmbH semiconductor division has been able to use its policy of continuous improvements to eliminate the use of ODSs listed in the following documents.

1. Annex A, B and list of transitional substances of the Montreal Protocol and the London Amendments respectively
2. Class I and II ozone depleting substances in the Clean Air Act Amendments of 1990 by the Environmental Protection Agency (EPA) in the USA
3. Council Decision 88/540/EEC and 91/690/EEC Annex A, B and C (transitional substances) respectively.

TEMIC can certify that our semiconductors are not manufactured with ozone depleting substances and do not contain such substances.

We reserve the right to make changes to improve technical design and may do so without further notice.

Parameters can vary in different applications. All operating parameters must be validated for each customer application by the customer. Should the buyer use TEMIC products for any unintended or unauthorized application, the buyer shall indemnify TEMIC against all claims, costs, damages, and expenses, arising out of, directly or indirectly, any claim of personal damage, injury or death associated with such unintended or unauthorized use.

TEMIC TELEFUNKEN microelectronic GmbH, P.O.B. 3535, D-74025 Heilbronn, Germany
Telephone: 49 (0)7131 67 2831, Fax number: 49 (0)7131 67 2423