

IR Receiver for Data Communication

Description

The IC U2538B is a complete IR receiver for data communication. The useful input signals are separated by a special input circuit and amplified by a gain-controlled amplifier. The bandpass filter suppresses the off-band signals. The signal detector, consisting of a demodulator,

an integrator and a Schmitt Trigger, forms the input signal to an output pulse that can be interfaced to a microcomputer. The AGC and the ATC circuit control the receiver's sensitivity, making it insensitive to ambient light sources.

Features

- Few external components
- Low power consumption
- Microcomputer compatible
- Insensitive to ambient light and other continuous interference

Applications

- Keyless entry systems
- Remote control
- Wireless data transfer up to 4 kbit/s

Ordering Information

Extended Type Number	Package	Remarks
U2538B-MFP	SO8	Tube
U2538B-MFPG3	SO8	Taped and reeled

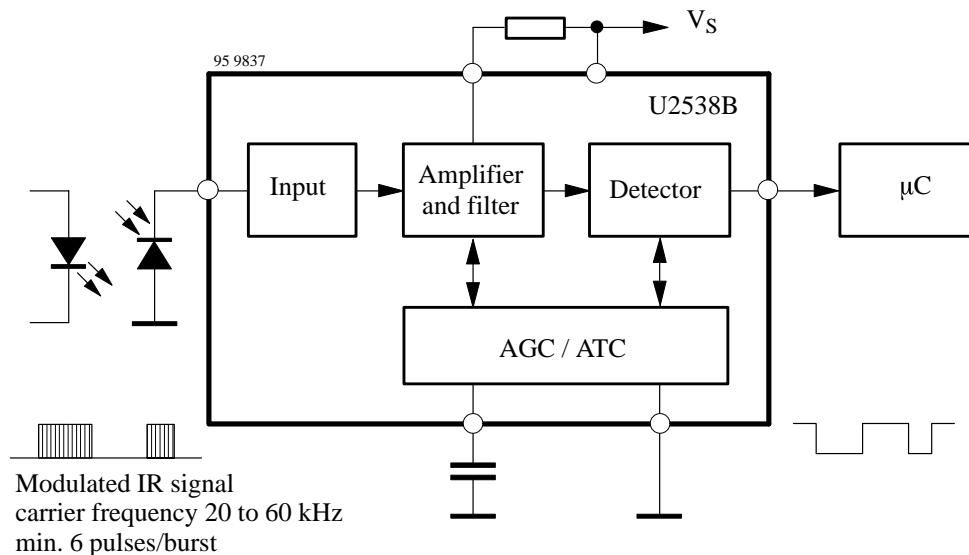
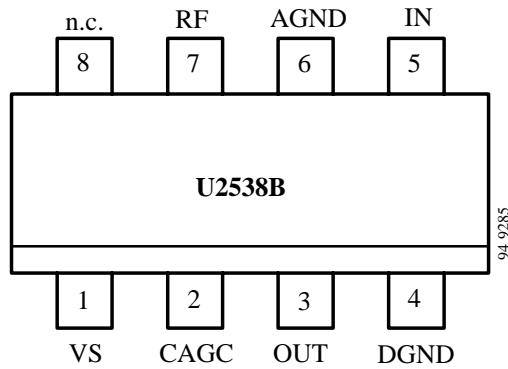

Figure 1.

Pin Description



Pin	Symbol	Function
1	VS	Supply voltage
2	CAGC	AGC capacitor
3	OUT	Data output
4	DGND	GND – DEM/INT/ST
5	IN	Input pin diode
6	AGND	GND amplifier
7	RF	Frequency determination
8	n.c.	Not connected

Figure 2. Pinning

Block Diagram

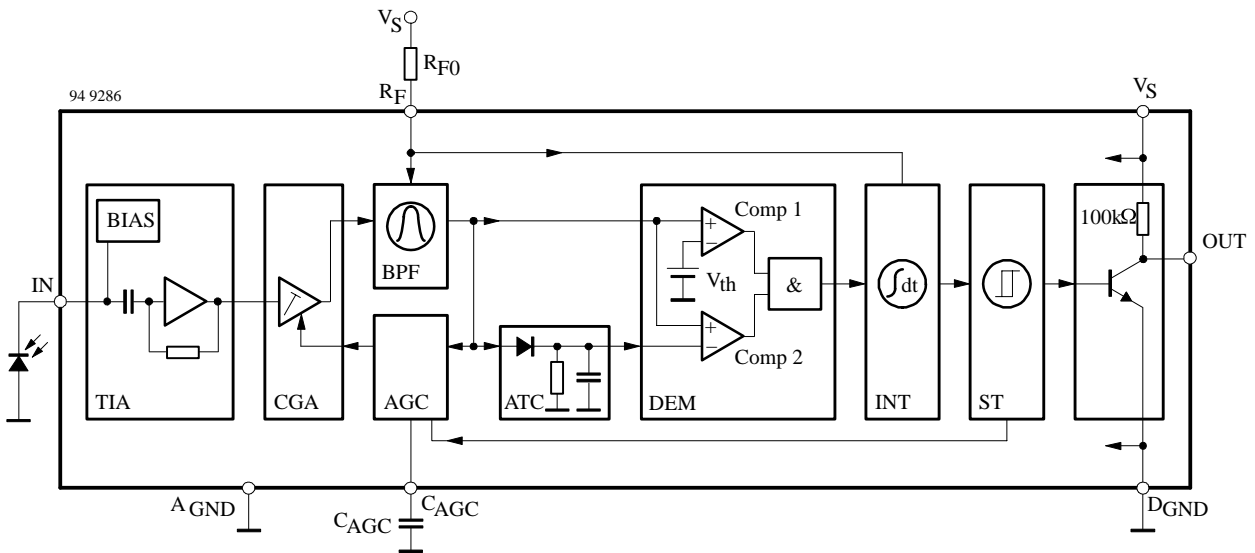

Figure 3. Block diagram

TIA Transimpedance amplifier
CGA Controlled gain amplifier
BPF Bandpass filter
AGC Automatic gain control

ATC Automatic threshold control
DEM Demodulator
INT Integrator
ST Schmitt trigger

Functional Description

Input Stage (TIA)

The input stage provides the necessary bias voltage for the photo diode and ensures decoupling of the useful signal. This involves processing the dc and ac portions in separate parts of the circuit: the bias voltage (BIAS) and the transimpedance amplifier circuit (TIA). The bias voltage circuit operates like a load resistor with respect to the photo diode, the value of which is low for dc and low-frequency signals (3 to 100 kΩ), but as high as possible for the operating frequency (100 kΩ to 1 MΩ) depending on the input current). The ac portion of the input signal feeds an inverted amplifier with a sufficiently low input resistance ($Z_i < 10 \text{ k}\Omega$). If the input resistance were too high, the useful signal would be lost to the junction capacitance of the photo diode.

Controlled Gain Amplifier (CGA)

The controlled gain amplifier accounts for the greatest part of the voltage gain and can be controlled via the voltage at C_{AGC} (Pin 2). Gain control is needed to support the interference suppression of the detector. High-pass behaviour results from the capacitive coupling of the individual stages. The cut-off frequency is approximately 20 kHz.

Bandpass Filter (BPF)

The bandpass filter basically consists of integrated components. An external resistor determines the mid-frequency. The filter quality is about 7 and is practically independent of the selected mid-frequency (see figure 4). The following formula can be used for calculating the resistor, R_{f0} :

$$R_{f0} \text{ (k}\Omega\text{)} = \frac{8855}{f_0 \text{ (kHz)}} - 13$$

where: $20 \text{ kHz} < f_0 < 60 \text{ kHz}$

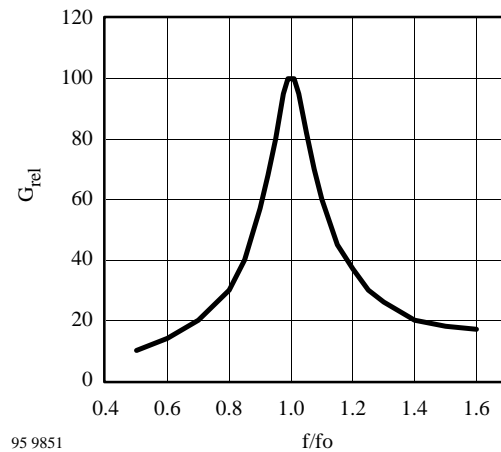

Figure 4. Characteristic of the bandpass filter

Automatic Threshold Control (ATC)

During the reception of an incoming telegram, the ATC reduces the sensitivity of the demodulator to establish the highest possible signal-to-noise ratio according to the signal strength. This prevents interferences which may arise during transmission from affecting the output. The advantage of the circuit is achieved, if its output voltage exceeds V_{Th} (Comp 1). That is the case when the input signal strength is more than twice as much as the minimum detectable signal intensity.

Automatic Gain Control (AGC)

The automatic gain control improves the circuit's resistance to interference by adapting the amplification of the gain controlled amplifier to the relevant existing interference level. In order to prevent the circuit from responding to transmitted data signals, it gradually reduces the sensitivity but only if the duty cycle exceeds a specific value (see figure 5). When using telegrams with higher duty cycles than this value, the capacitor, C_{AGC} , maintains the sensitivity for a certain time period. A higher capacitance enables a longer transmission time. A capacitance of $C_1 = 22 \text{ nF}$ is adequate for most known telegrams. A typical value for the maximum duty cycle (DC) can be calculated by the following formula:

$$DC_{\max} = \frac{N}{14.2 + 1.1 \times N}$$

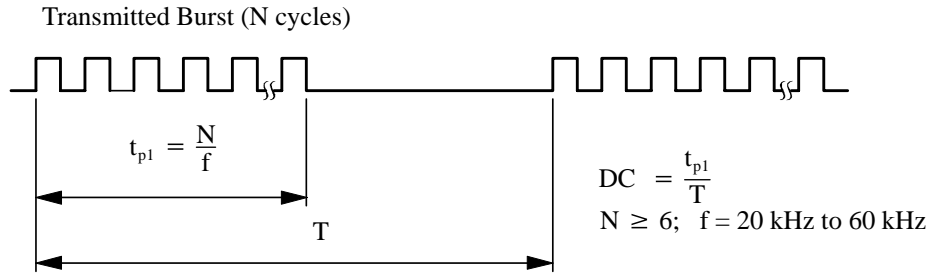

94 9287

Figure 5.

Detector

The output signal of the bandpass filter is compared to a fixed reference (Comp 1) and to a reference generated by the ATC circuit (Comp 2). The output of the comparator with the higher threshold voltage controls the integrator. Using the integrator keeps the output free of short-time interference.

The integrator drives the output stage after being processed through a Schmitt Trigger. The internal pull-up resistor can replace an external resistor in some applications.

Absolute Maximum Ratings

Parameters	Symbol	Value	Unit
Supply voltage Pin 1	V_S	-0.3 to +6.0	V
Input voltages Pins 2, 3 and 5 Pin 7	V_{IN}	-0.3 to V_S -0.3 to +1.5	V
Input current Pin 7	I_{IN}	0 to 0.1	mA
Power dissipation $T_{amb} = 105^\circ\text{C}$	P_{tot}	110	mW
Junction temperature	T_j	125	$^\circ\text{C}$
Ambient temperature	T_{amb}	-40 to +105	$^\circ\text{C}$
Storage temperature	T_{stg}	-40 to +125	$^\circ\text{C}$

Maximum Thermal Resistance

Parameters	Symbol	Maximum	Unit
Junction ambient	R_{thJA}	180	K/W

Electrical Characteristics

$T_{amb} = 25^{\circ}\text{C}$, $V_s = 5\text{ V}$

Parameters	Test Conditions / Pins	Symbol	Min.	Typ.	Max.	Unit
Supply voltage	Pin 1	V_S	4.5		5.5	V
Supply current	Pin 1	I_S	0.35		0.65	mA
Max. input current $V_{IN} = 0$	Pin 5	I_{IN}	0.6			mA
Output voltage low: $I_{OL} = 2\text{ mA}$	Pin 3	V_{OL}			0.2	V
Internal pull-up resistor	Pin 3	R_L	75	100	125	k Ω
Center frequency of band-pass RF = 240 k		f_0	33.3	35	36.7	kHz
Q factor		Q		7		
Frequency range		f	20		60	kHz
AGC current source sink	Pin 2		90 70	120 100	155 140	nA nA
AGC slope	Pin 2			20		dB/V
Number of pulses required			6			
Sensitivity	Pin 5				0.7	nA(rms)
Switch-on delay, $i_{IN} = 0.7\text{ nA (rms)}$	Pin 3 see figure 6	t_{don}	3		7.5	Period
Switch-off delay, $i_{IN} = 0.7\text{ nA (rms)}$	Pin 3 see figure 6	t_{doff}	5		10	Period
Pulse width, $i_{IN} = 0.7\text{ nA (rms)}$, 6 pulse bursts	Pin 3 see figure 6	t_{po}	4.5		10	Period

$$R_{i0} \text{ (k}\Omega\text{)} = \frac{8855}{f_0 \text{ (kHz)}} - 13 \text{ k}\Omega$$

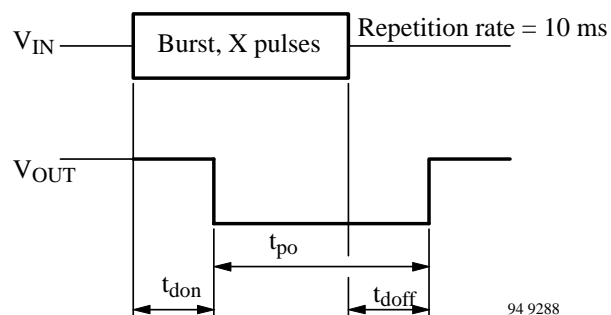

Figure 6.

Application Circuit

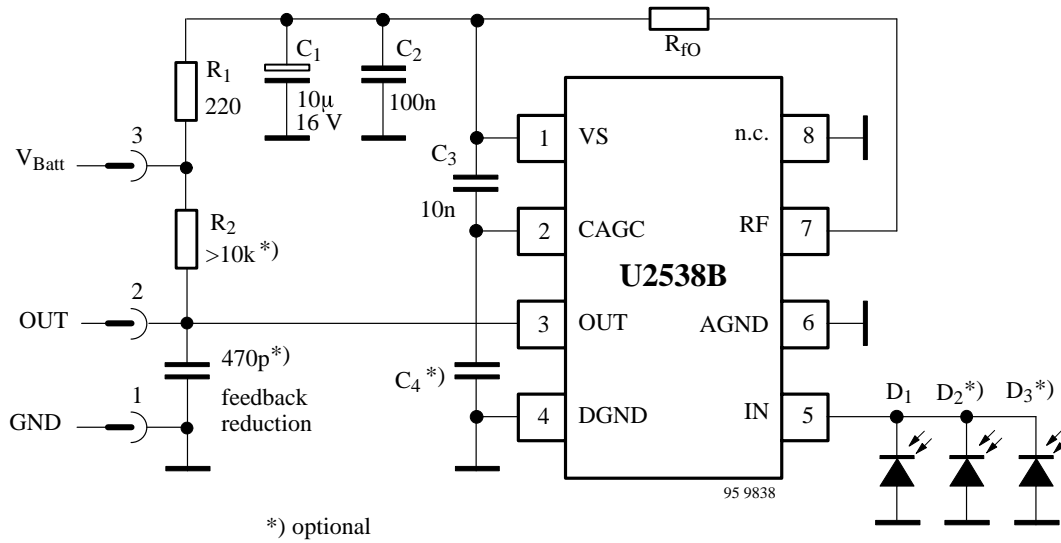
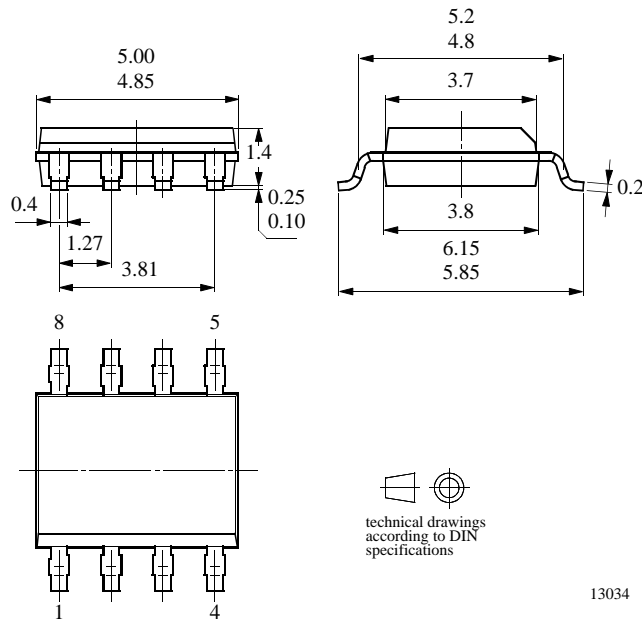

Figure 7. Application circuit

Package Information

Package SO8

Dimensions in mm



Ozone Depleting Substances Policy Statement

It is the policy of **TEMIC Semiconductor GmbH** to

1. Meet all present and future national and international statutory requirements.
2. Regularly and continuously improve the performance of our products, processes, distribution and operating systems with respect to their impact on the health and safety of our employees and the public, as well as their impact on the environment.

It is particular concern to control or eliminate releases of those substances into the atmosphere which are known as ozone depleting substances (ODSs).

The Montreal Protocol (1987) and its London Amendments (1990) intend to severely restrict the use of ODSs and forbid their use within the next ten years. Various national and international initiatives are pressing for an earlier ban on these substances.

TEMIC Semiconductor GmbH has been able to use its policy of continuous improvements to eliminate the use of ODSs listed in the following documents.

1. Annex A, B and list of transitional substances of the Montreal Protocol and the London Amendments respectively
2. Class I and II ozone depleting substances in the Clean Air Act Amendments of 1990 by the Environmental Protection Agency (EPA) in the USA
3. Council Decision 88/540/EEC and 91/690/EEC Annex A, B and C (transitional substances) respectively.

TEMIC Semiconductor GmbH can certify that our semiconductors are not manufactured with ozone depleting substances and do not contain such substances.

We reserve the right to make changes to improve technical design and may do so without further notice.

Parameters can vary in different applications. All operating parameters must be validated for each customer application by the customer. Should the buyer use TEMIC products for any unintended or unauthorized application, the buyer shall indemnify TEMIC against all claims, costs, damages, and expenses, arising out of, directly or indirectly, any claim of personal damage, injury or death associated with such unintended or unauthorized use.

TEMIC Semiconductor GmbH, P.O.B. 3535, D-74025 Heilbronn, Germany
Telephone: 49 (0)7131 67 2594, Fax number: 49 (0)7131 67 2423

This datasheet has been download from:

www.datasheetcatalog.com

Datasheets for electronics components.