

Klemmen

NTC's

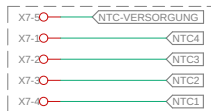

Zellenspannungen

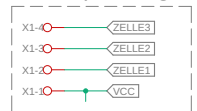

I2C Display

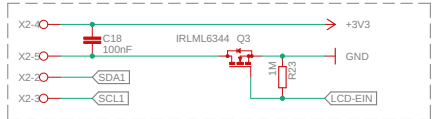

Wassermelder und Bedienung



Akkupack



Programmierport

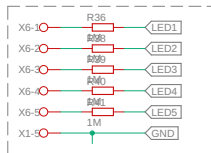
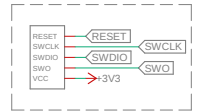

Akku Schutzschaltung

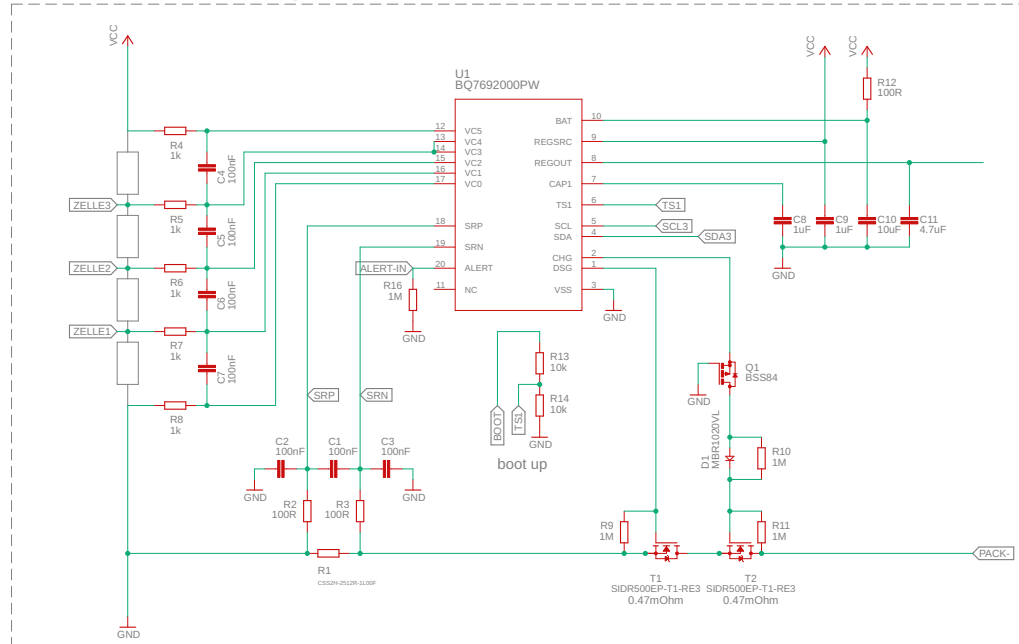

STM32WB5MM

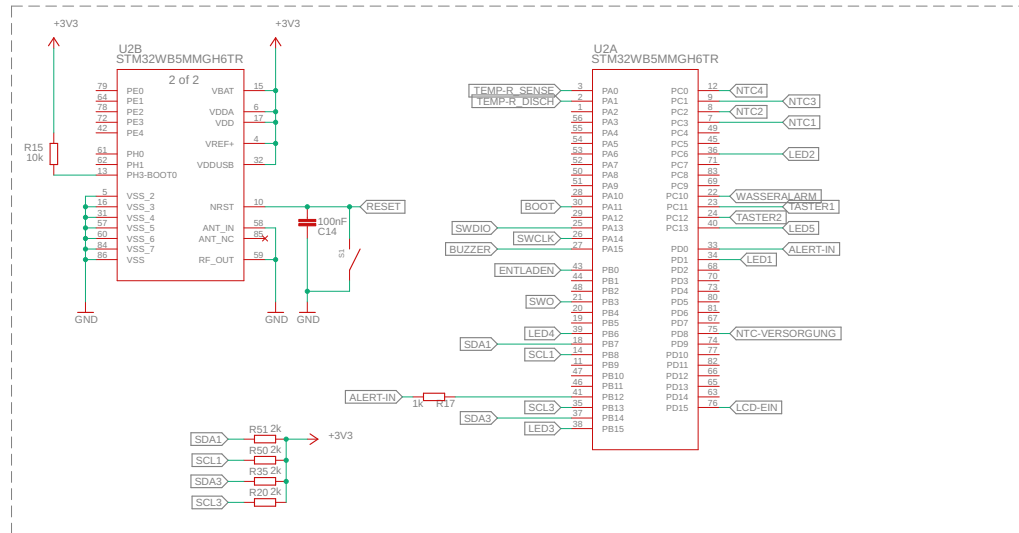

3,3V Versorgung

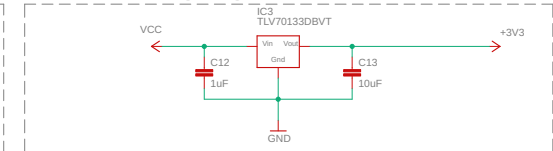

Temperaturmessungen

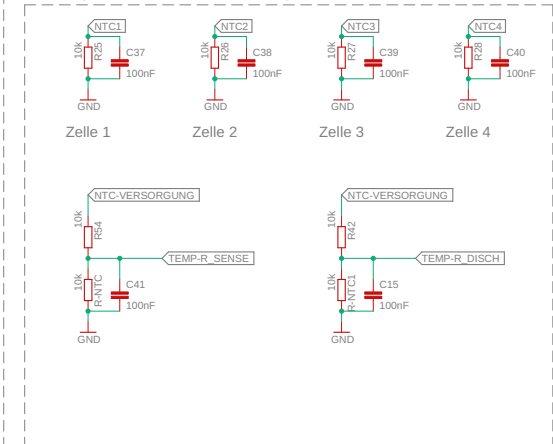

Wassermelder und Bedienung

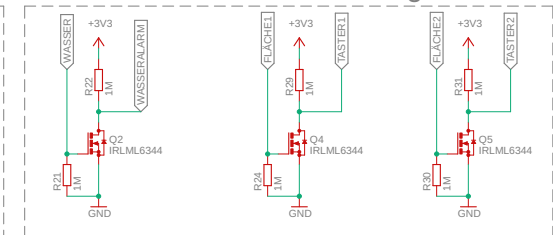

Buzzer

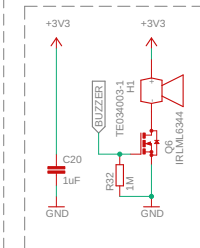

Entladewiderstand

