

Input voltage:  
12.24V  
(9.6..28.6V)

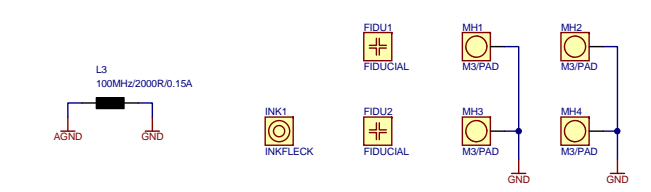

\* Not assembled components

<b>ARM7-Controllerboard</b>	Created:	01.10.2009	TPL
	Checked:	<CheckDate>	<CheckedBy>
	Document No.:	2200.0002.3	A
	Sheet:	1 / 8	

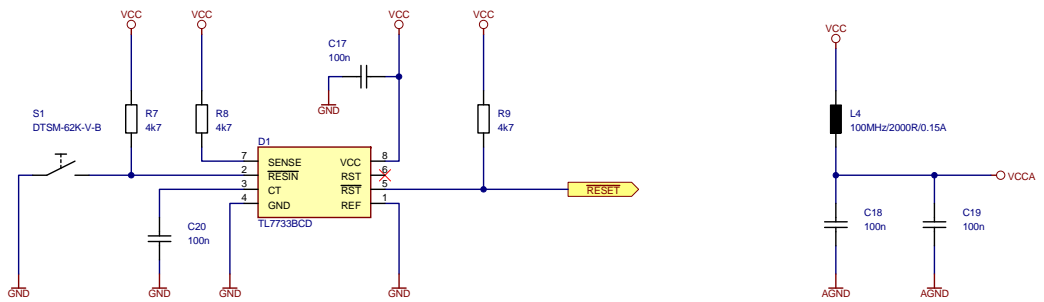
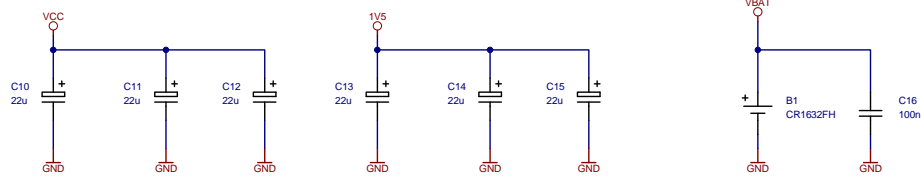
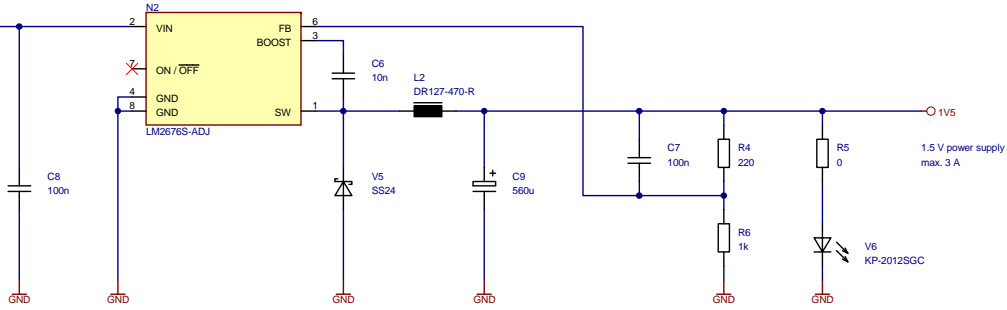
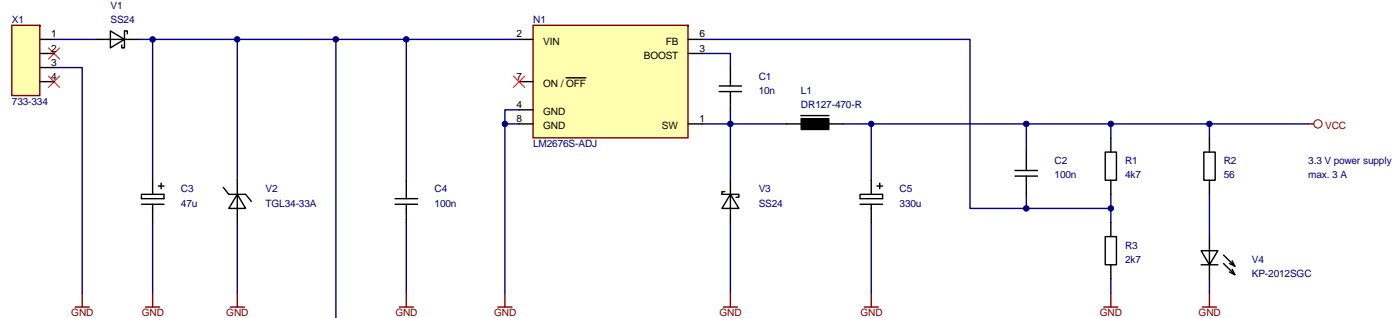

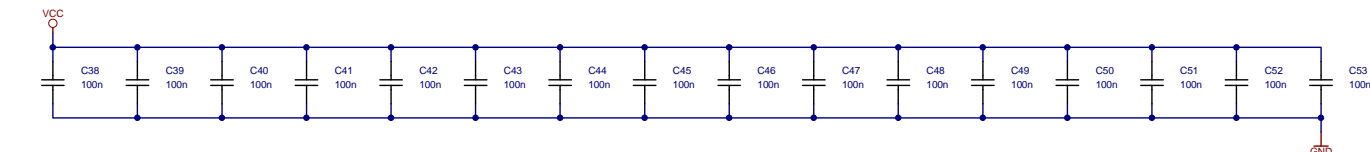
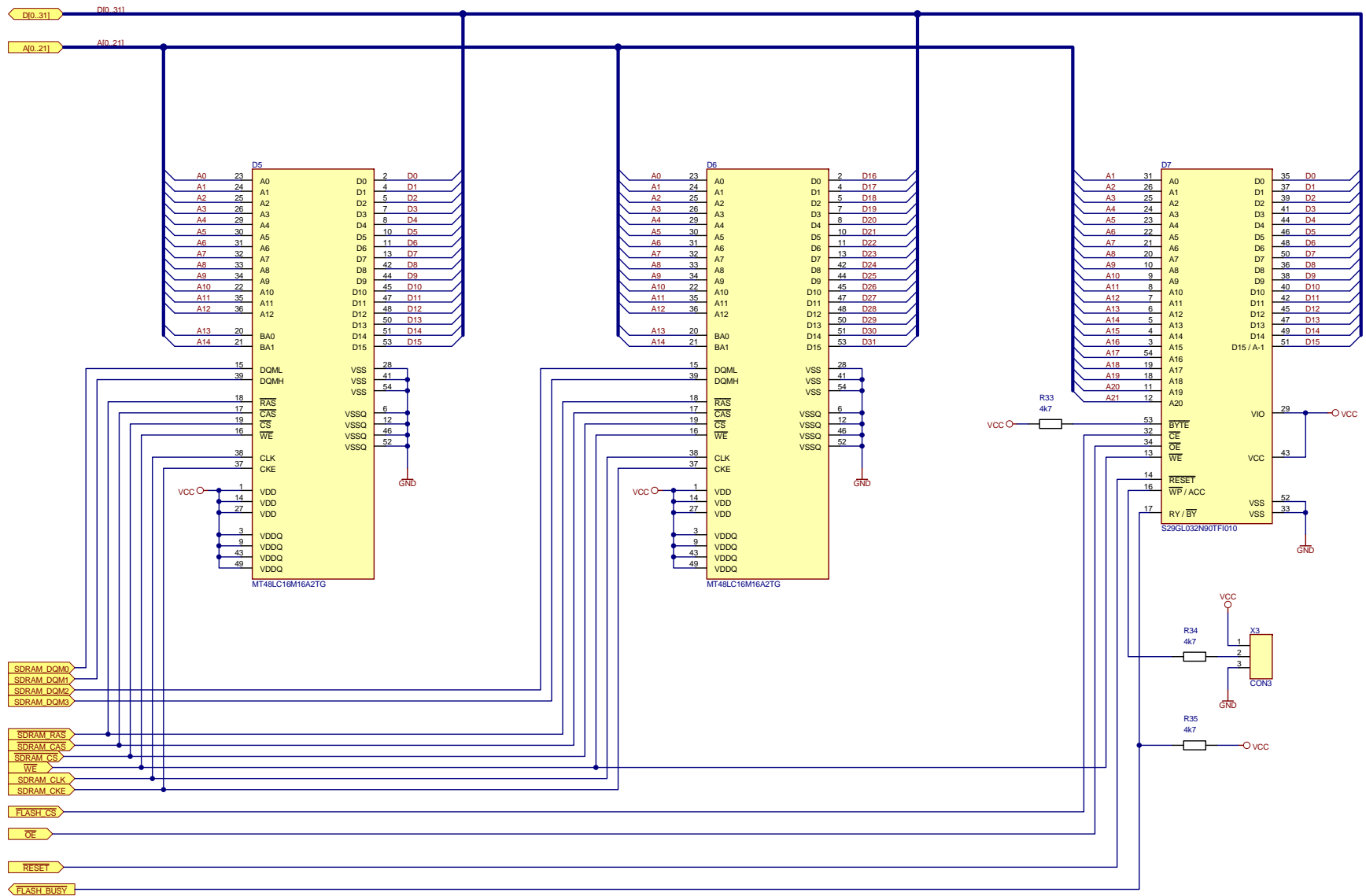

\* Not assembled components

ARM7-Controllerboard		
Created:	01.10.2009	TPL
Checked:	<CheckDate>	<CheckedBy>
Document No.:	2200.0002.3	A
Sheet:	3 / 8	

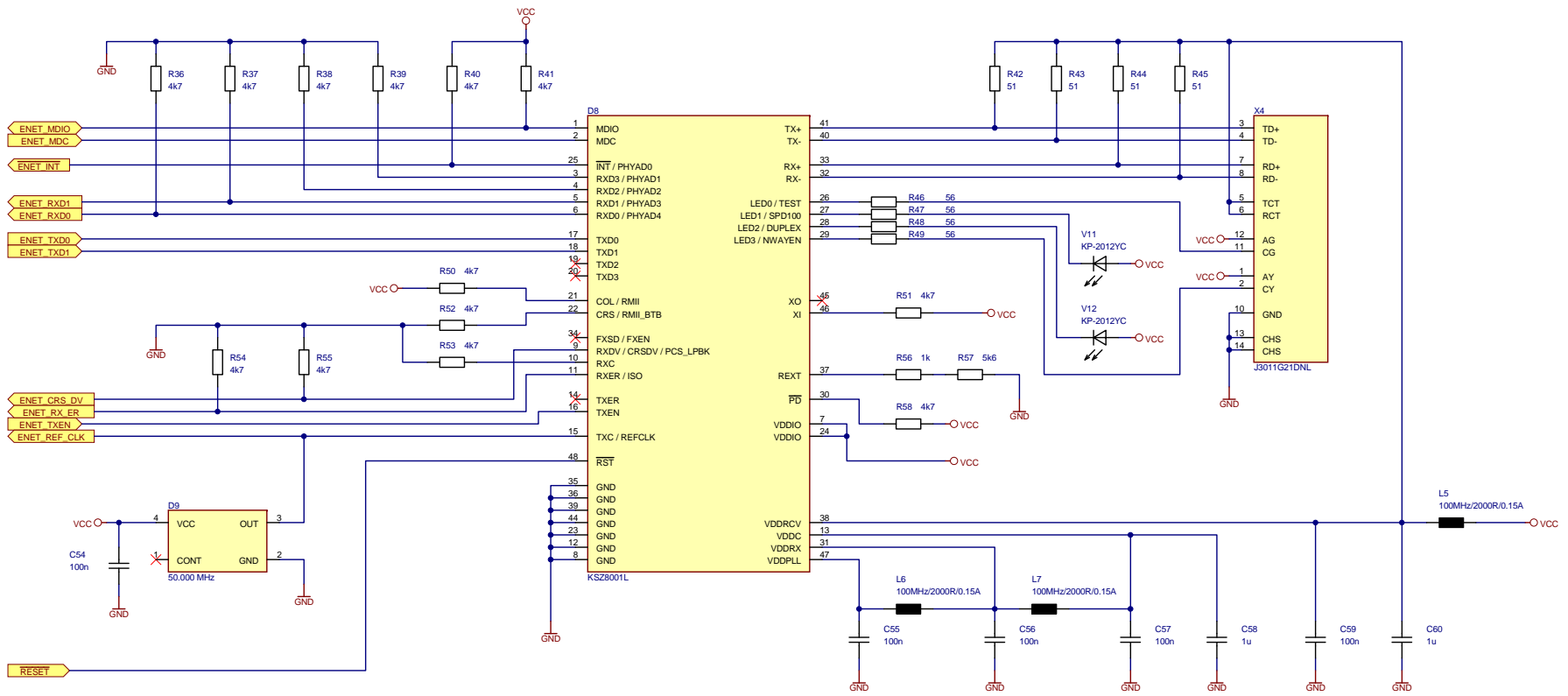

\* Not assembled components

ARM7-Controllerboard			
Created:	01.10.2009	TPL	
Checked:	<CheckDate>	<CheckedBy>	
Document No.:	2200.0002.3	A	
Sheet:	4 / 8		







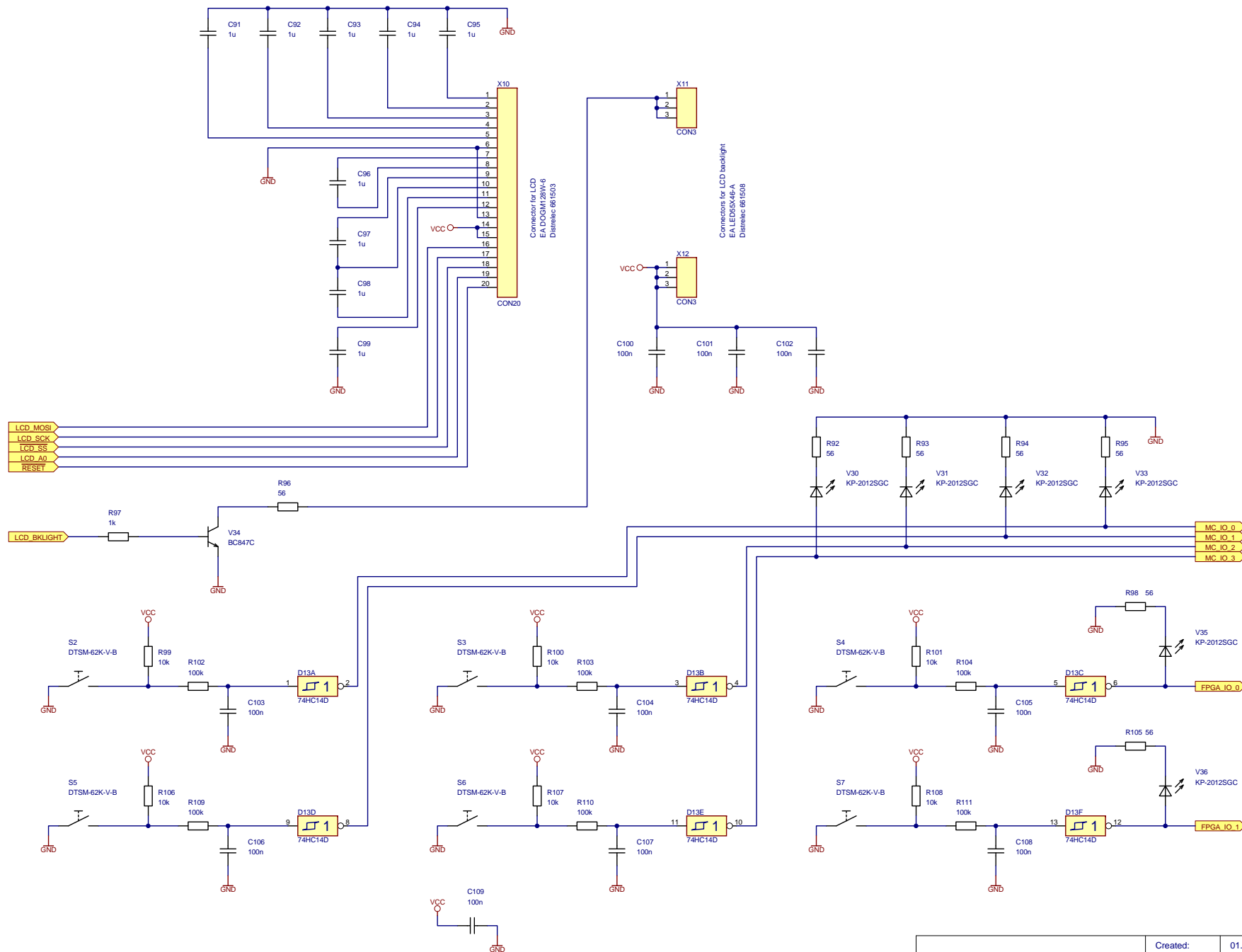

\* Not assembled components

ARM7-Controllerboard			
Created:	01.10.2009	TPL	
Checked:	<CheckDate>	<CheckedBy>	
Document No.:	2200.0002.3	A	
Sheet:	8 / 8		