



1 KEY TOUCH PAD DETECTOR IC

GENERAL DESCRIPTION

The TTP233B-HA6 TonTouch™ is a touch pad detector IC which offers 1 touch key. The device built-in regulator for touch sensor. Stable sensing method can cover diversity condition. The touching detection IC is designed for replacing traditional direct button key with diverse pad size. Low power consumption and wide operating voltage are the contact key features for DC or AC application.

FEATURES

- Operating voltage 2.4V~5.5V
- Built-in regulator for touch sensor
- TTP233B-HA6 Operating current @ VDD=3V, no load
At low power mode typical 2.5uA, maximum 5uA
- The response time max about 220mS at low power mode @VDD=3V
- Sensitivity can adjust by the capacitance(1~50pF) outside
- Stable touching detection of human body for replacing traditional direct switch key
- Provides Low Power mode
- Provides direct output or toggle output selection by pad option(TOG pin)
- Q pin is CMOS output can be selected active high or active low by pad option(AHLB pin)
- Have the maximum on time 16 sec
- After power-on have about 0.5 sec stable-time, during the time do not touch the key pad,
And the function is disabled
- Auto calibration for life
The re-calibration period is about 1 sec within 8 sec after power-on. When key has be touched within 8 sec or key has not be touched more than 8 sec after power-on, then the re-calibration period change to 4 sec.

APPLICATION

- Wide consumer products
- Button key replacement



BLOCK DIAGRAM

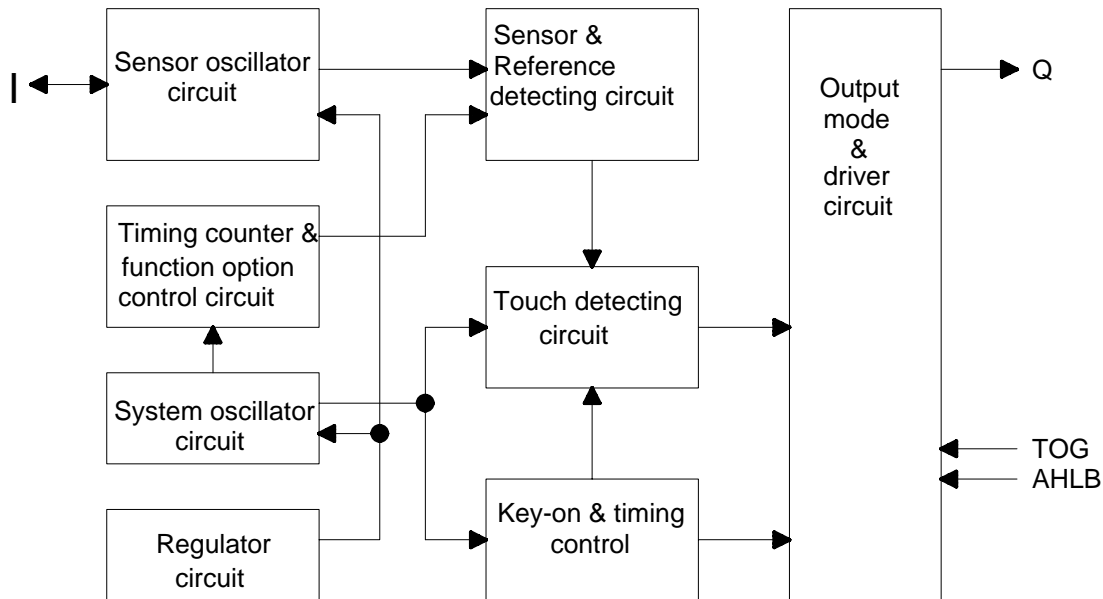

PACKAGE CONFIGURATION

TTP233B-HA6 : Package Type SOT-23

TTP233B-HA6 SOT-23

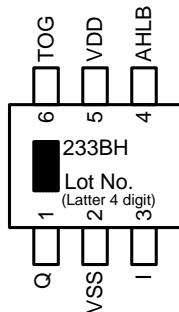

PAD DESCRIPTION

Pad No.	Pad Name	I/O Type	Pad Description
1	Q	O	CMOS output pin
2	VSS	P	Negative power supply, ground
3	I	I/O	Input sensor port
4	AHLB	I-PL	Output Q active high or low selection, 0(Default)=>Active high ; 1=>Active low
5	VDD	P	Positive power supply
6	TOG	I-PL	Output type option pin, 0(Default)=>Direct output ; 1=>Toggle output

Pin Type

- O : CMOS push-pull output
- I/O : CMOS I/O
- I-PL : CMOS input and pull-low resistor
- P : Power / Ground

**ELECTRICAL CHARACTERISTICS**• **Absolute Maximum Ratings**

Parameter	Symbol	Conditions	Value	Unit
Operating Temperature	T _{OP}	—	-40 ~ +85	°C
Storage Temperature	T _{STG}	—	-50 ~ +125	°C
Power Supply Voltage	VDD	T _a =25°C	VSS-0.3 ~ VSS+5.5	V
Input Voltage	V _{IN}	T _a =25°C	VSS-0.3 ~ VDD+0.3	V
Human Body Mode	ESD	—	7	KV

Note : VSS symbolizes for system ground

• **DC/AC Characteristics** : (Test condition at room temperature=25°C)

Parameter	Symbol	Test Condition	Min.	Typ.	Max	Unit
Operating Voltage	VDD		2.4	3	5.5	V
Internal Regulator Output	VREG		2.2	2.3	2.4	V
System oscillator	F _{FAST}	VDD=3V		512K		Hz
	F _{LOW}			16K		
Sensor oscillator	F _{SEN}	VDD=3V no load	-	1M	-	Hz
Operating Current TTP233B-HA6 IC	I _{OP}	VDD=3V output no load	Low power mode	2.5	5	uA
			Fast mode	5.0	10	
Input Ports	V _{IL}	Input Low Voltage	0	-	0.2	VDD
Input Ports	V _{IH}	Input High Voltage	0.8	-	1.0	VDD
Output Port Sink Current	I _{OL}	VDD=3V, V _{OL} =0.6V	-	8	-	mA
Output Port Source Current	I _{OH}	VDD=3V, V _{OH} =2.4V	-	-4	-	mA
Output Response Time	T _R	VDD=3V, At fast mode			60	mS
		VDD=3V, At low power mode			220	
Input Pin Pull-low Resistor	R _{PL}	VDD=3V, (TOG, AHLB)		25K		ohm



FUNCTION DESCRIPTION

1. Sensitivity adjustment

The total loading of electrode size and capacitance of connecting line on PCB can affect the sensitivity. So the sensitivity adjustment must according to the practical application on PCB. The TTP233B-HA6 offers some methods for adjusting the sensitivity outside.

1-1 by the electrode size

Under other conditions are fixed. Using a larger electrode size can increase sensitivity. Otherwise it can decrease sensitivity. But the electrode size must use in the effective scope.

1-2 by the panel thickness

Under other conditions are fixed. Using a thinner panel can increase sensitivity. Otherwise it can decrease sensitivity. But the panel thickness must be below the maximum value.

1-3 by the value of Cs (please see the down figure)

Under other conditions are fixed. When do not use the Cs to VSS, the sensitivity is most sensitive. When adding the values of Cs will reduce sensitivity in the useful range (1pF Cs 50pF).

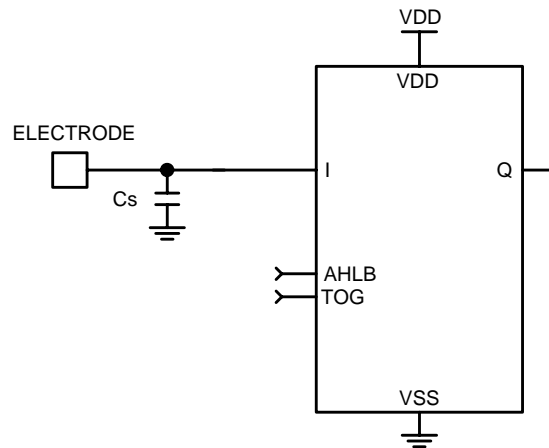

2. Output mode (By TOG, AHLB pad option)

TOG pad: Direct output or toggle output selection .

AHLB pad: Output Q active high or active low selection.

Pad Q (CMOS output) option features:

TOG	AHLB	Pad Q option features
0	0	Direct output, CMOS active high
0	1	Direct output, CMOS active low
1	0	Toggle output, power on state =0
1	1	Toggle output, power on state =1

3. Maximum key on duration time

If some objects cover in the sense pad, and causing the change quantity enough to be detected. To prevent this, the TTP233B-HA6 sets a timer to monitor the detection. The timer is the maximum on duration time. It is set about 16 sec at 3V. When the detection is over the timer, the system will return to the power-on initial state, and the output becomes inactive until the next detection.



4. Low power mode

The TTP233B-HA6 is Low Power mode. it will be saving power. When detecting key touch, it will switch to Fast mode. Until the key touch is released and will keep a time about 10 sec. Then it returns to Low Power mode.

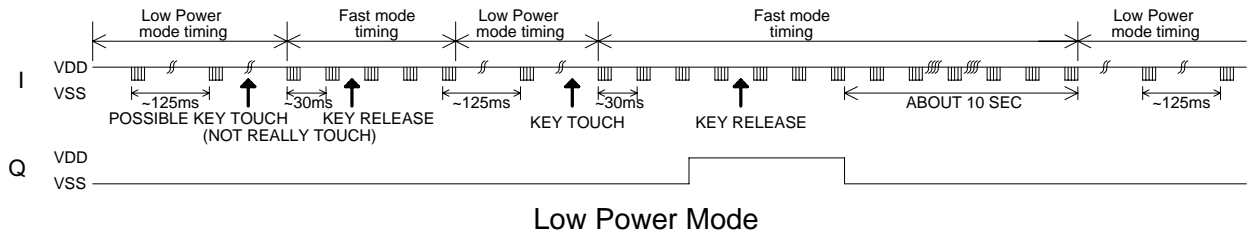

5. Option pin

For power saving concern and package bonding option consideration, all the feature option pins with latch type design and initial states are 0 or 1 as power on. If those pins are forced to VDD or VSS, the states will be changed to 1 or 0 without any current leakage to conflict the power saving issue.

Feature option pins	Initial state by Power on
AHLB	0
TOG	0

APPLICATION CIRCUIT

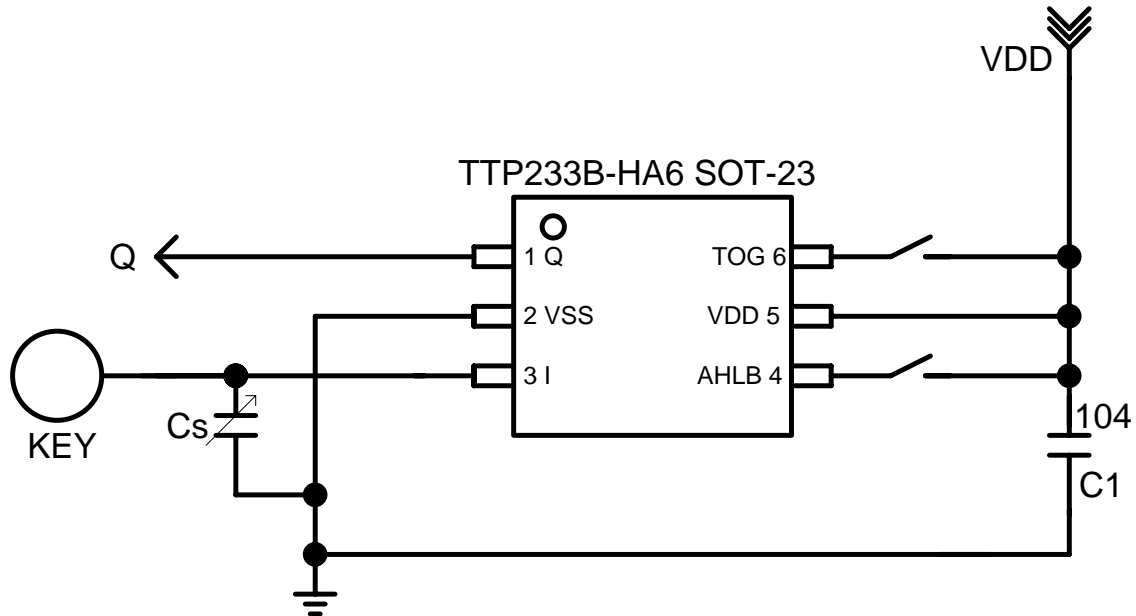

- PS :
1. On PCB, the length of lines from touch pad to IC pin shorter is better.
And the lines do not parallel and cross with other lines.
 2. The power supply must be stable. If the supply voltage drift or shift quickly, maybe causing sensitivity anomalies or false detections.
 3. The material of panel covering on the PCB can not include the metal or the electric element.
The paints on the surfaces are the same.
 4. The capacitance C_s can be used to adjust the sensitivity. The value of C_s use smaller, then the sensitivity will be better. The sensitivity adjustment must according to the practical application on PCB. The range of C_s value is 1~50pF.
 5. The C_1 capacitor must be used between VDD and VSS; and should be routed with very short tracks to the device's VDD and VSS pins .
 6. The sensitivity adjustment capacitors (C_s) must use smaller temperature coefficient and more stable capacitors. Such are X7R, NPO for example. So for touch application, recommend to use NPO capacitor, for reducing that the temperature varies to affect sensitivity.



Package Type: SOT-23-6L

Package Outline Dimension

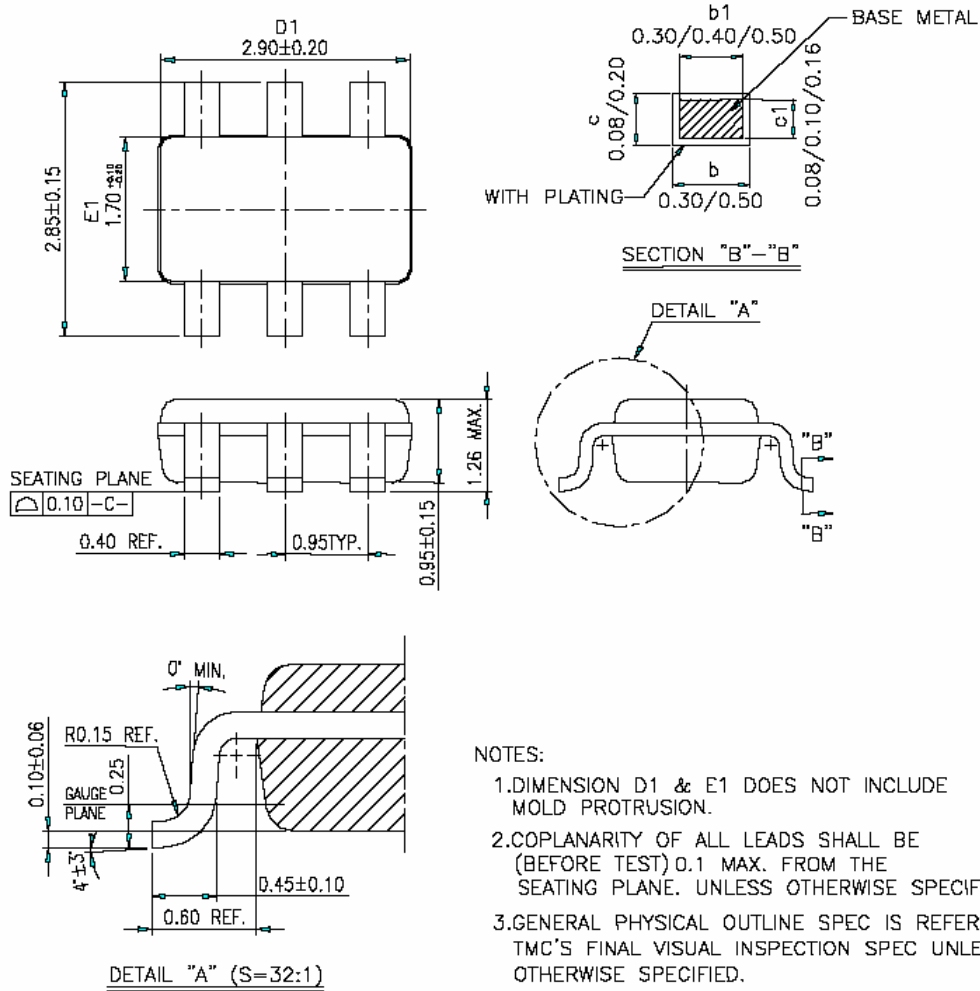



Preliminary

TTP233B-HA6
TonTouch™

ORDER INFORMATION

a. Package form: TTP233B-HA6

REVISE HISTORY

1. 2011/08/30

-Original version : V_1.0