

Power 5V

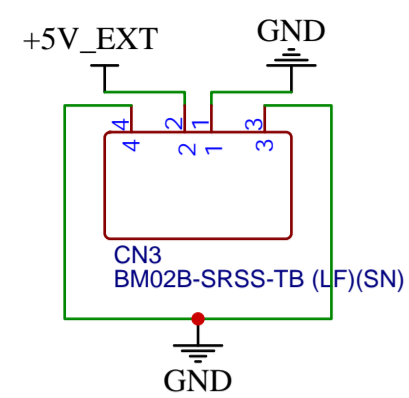

ESP32

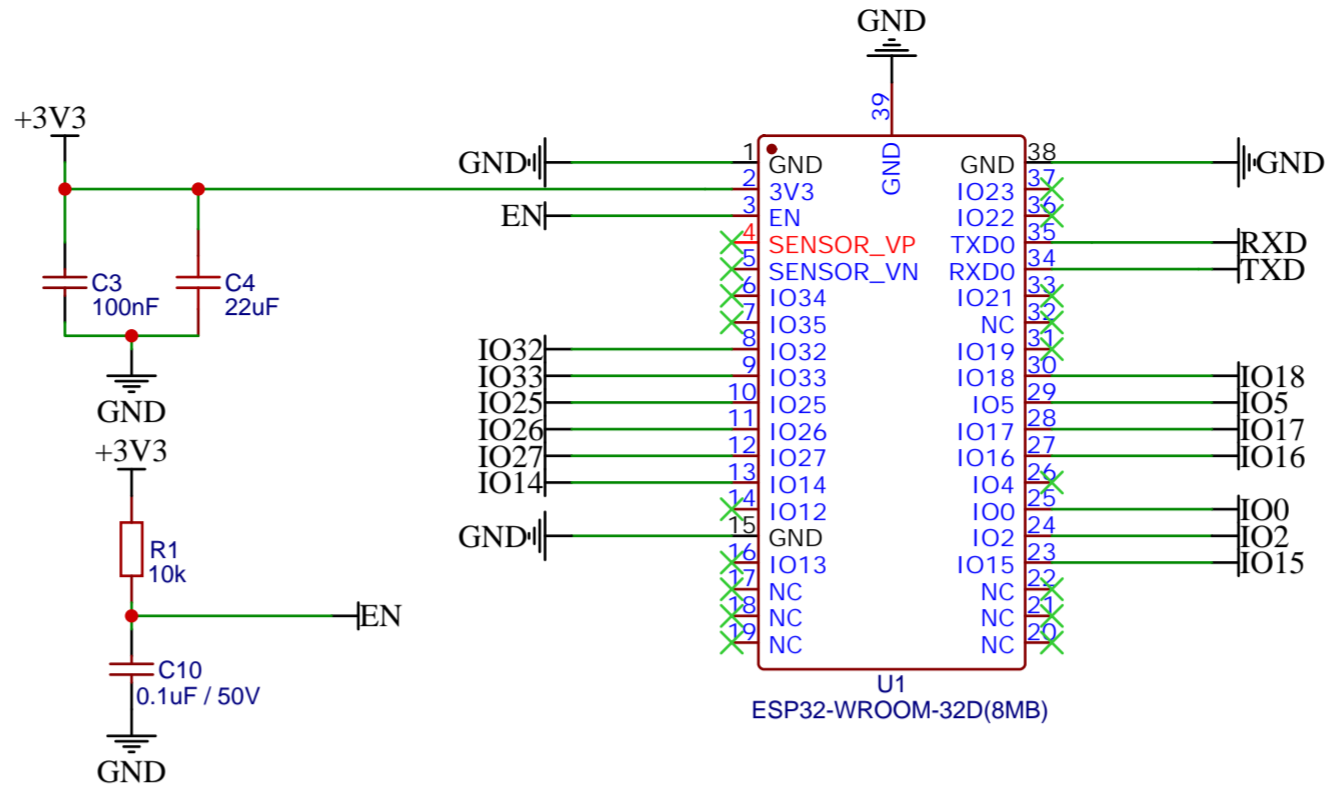

Power 5V -> 3.3V @1A

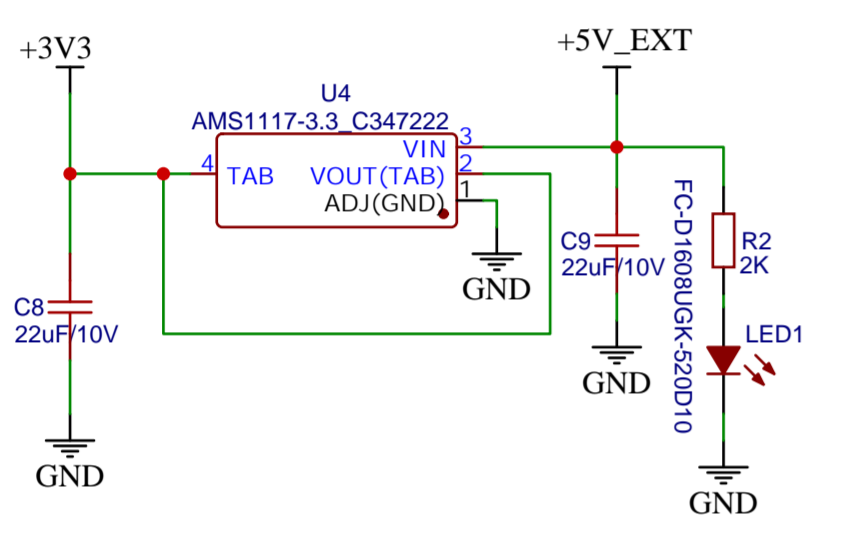

Switch Buttons ESP32

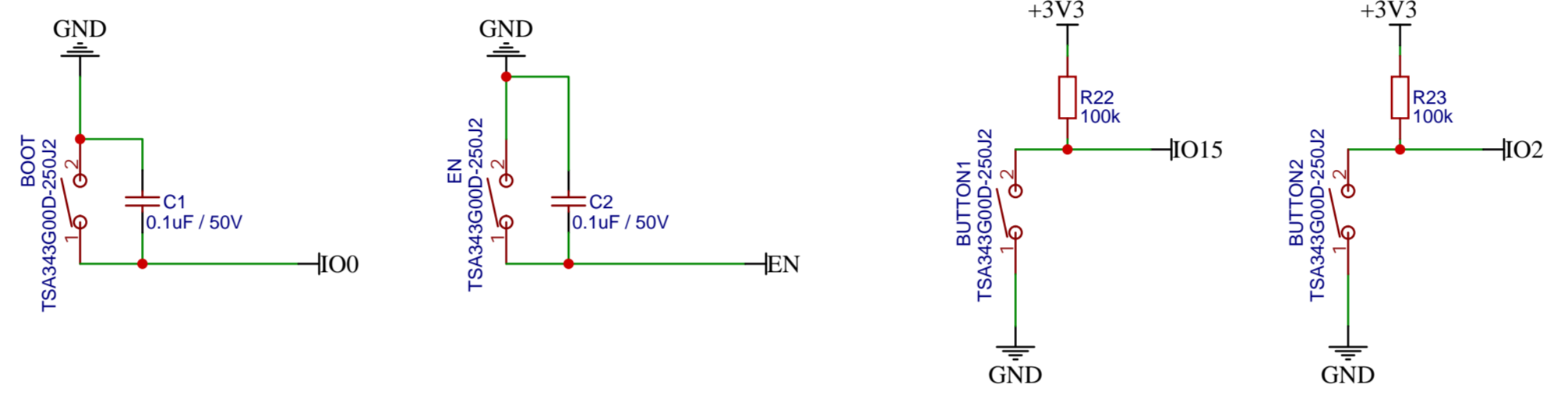

USB C Power & UART

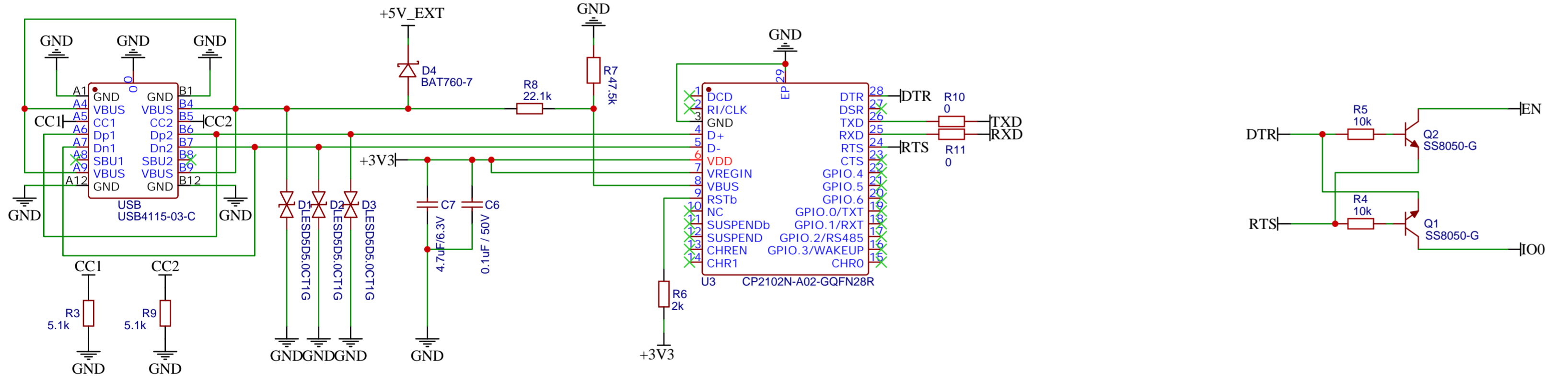

Terminals & Levelshifter & Mosfet

