

# EVB-USB2240-IND

Evaluation Board for USB2240, 36 pin QFN

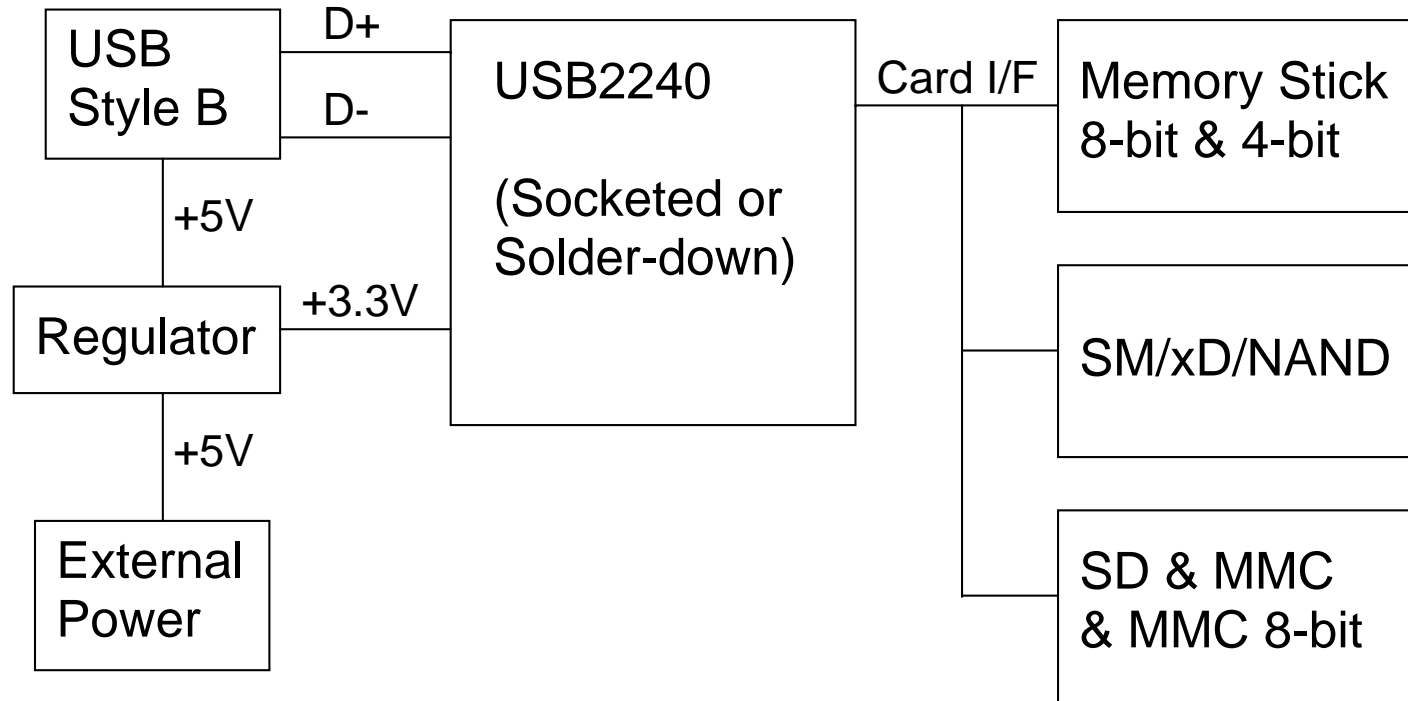

## Revision History

Rev.	Date	Revision Summary	Author
0.1	20070727	Initial design - based on SVB-USB2240QFN36B (Thamyris), Rev. 01	C. Johnson
0.2	20070730	Moved 1.0uF cap to far side of 5V selector to reduce in-rush current.	C. Johnson
0.3	20070828	Added optional EEPROM for configuration.	H. Magnusson
0.4	20070917	Added VBUS detect option for self-powered mode.	H. Magnusson
0.5	20070924	Revised DNP options, replaced 5V source jumper with resistors, replaced SM socket with xD socket, replaced 0805s w/ 0603, updated MMC socket.	C. Johnson
0.6	20070925	Renumbered.	C. Johnson
0.7	20070926	Changes to support new layout.	C. Johnson
A	20070928	Renumbered -- Released.	C. Johnson
02B	20071109	Added series termination, EMI treatments, changed MS connector.	C. Johnson
03B	20080711	Replaced caps with 0402s as needed, added guide post for MS connector, added PU to GPIO7 for MS 8-bit.	C. Johnson
B	20080721	Released.	C. Johnson
B1	20090612	Updated C14/C18 load capacitors on the crystal from 33 to 18 pF	H. Magnusson

