

NOTES:  
 MATERIAL:  
 HOUSING: NYLON UL94V-0  
 LATCH: PPS UL94V-0  
 TERMINAL: PHOSPER BRONZE  
 FITTING NAIL: PHOSPER BRONZE  
 ▲ PLATING P.L.S. SEE ACES PLATING CODE

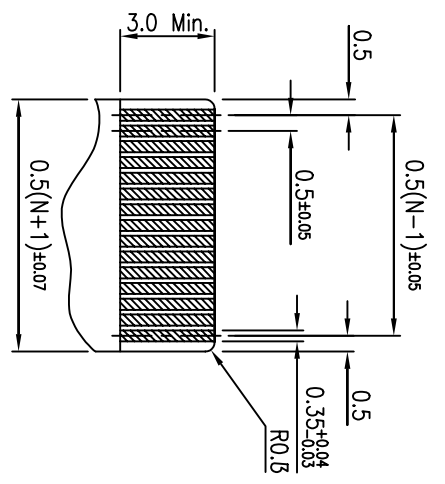

RECOMMENDED APPLICABLE PFC LAYOUT  
 (THICKNESS: 0.3±0.03)

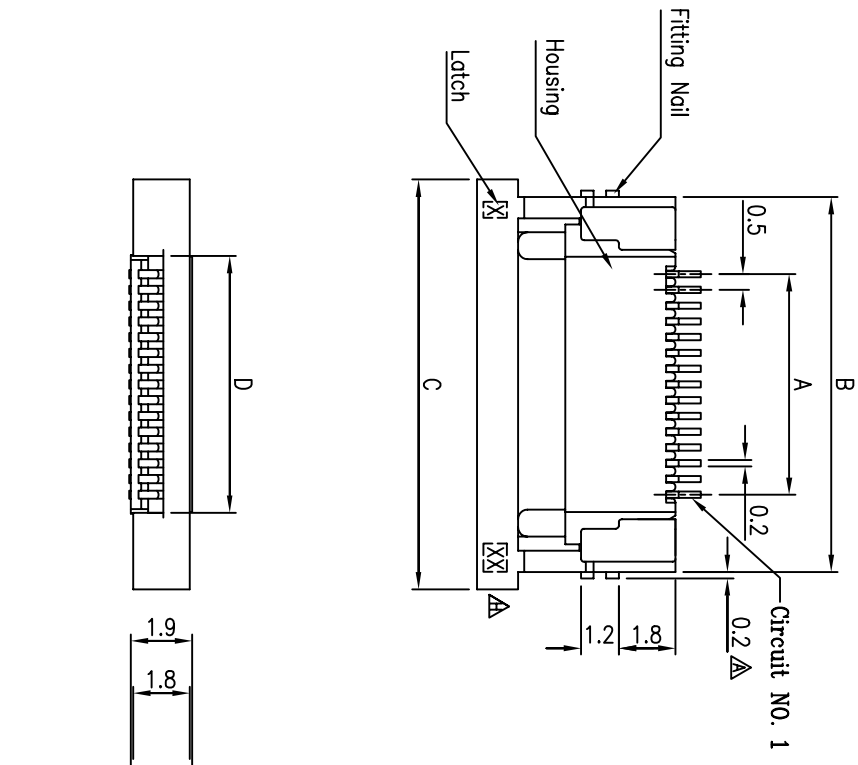
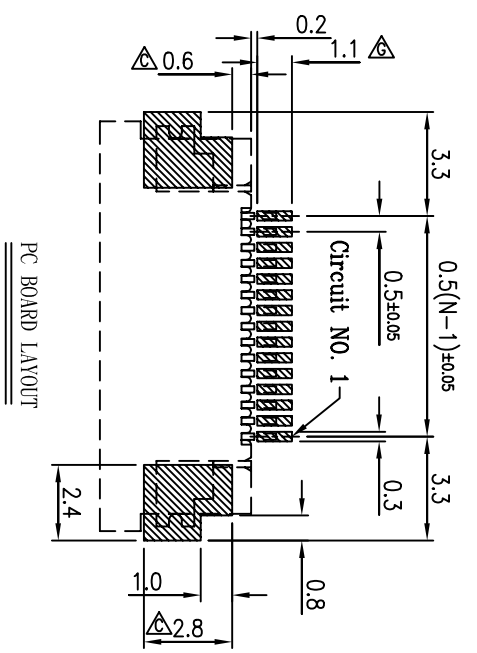

CKT	DIM A	DIM B	DIM C	DIM D	CKT	DIM A	DIM B	DIM C	DIM D
4	1.5	6.4	7.5	2.65	35	17.0	21.9	23.0	18.15
5	2.0	6.9	8.0	3.15	36	17.5	22.4	23.5	18.65
6	2.5	7.4	8.5	3.65	37	18.0	22.9	24.0	19.15
7	3.0	7.9	9.0	4.15	38	18.5	23.4	24.5	19.65
8	3.5	8.4	9.5	4.65	39	19.0	23.9	25.0	20.15
9	4.0	8.9	10.0	5.15	40	19.5	24.4	25.5	20.65
10	4.5	9.4	10.5	5.65	41	20.0	24.9	26.0	21.15
11	5.0	9.9	11.0	6.15	42	20.5	25.4	26.5	21.65
12	5.5	10.4	11.5	6.65	43	21.0	25.9	27.0	22.15
13	6.0	10.9	12.0	7.15	44	21.5	26.4	27.5	22.65
14	6.5	11.4	12.5	7.65	45	22.0	26.9	28.0	23.15
15	7.0	11.9	13.0	8.15	46	22.5	27.4	28.5	23.65
16	7.5	12.4	13.5	8.65	47	23.0	27.9	29.0	24.15
17	8.0	12.9	14.0	9.15	48	23.5	28.4	29.5	24.65
18	8.5	13.4	14.5	9.65	49	24.0	28.9	30.0	25.15
19	9.0	13.9	15.0	10.15	50	24.5	29.4	30.5	25.65
20	9.5	14.4	15.5	10.65	51	25.0	29.9	31.0	26.15
21	10.0	14.9	16.0	11.15	52	25.5	30.4	31.5	26.65
22	10.5	15.4	16.5	11.65	53	26.0	30.9	32.0	27.15
23	11.0	15.9	17.0	12.15	54	26.5	31.4	32.5	27.65
24	11.5	16.4	17.5	12.65	55	27.0	31.9	33.0	28.15
25	12.0	16.9	18.0	13.15	56	27.5	32.4	33.5	28.65
26	12.5	17.4	18.5	13.65	57	28.0	32.9	34.0	29.15
27	13.0	17.9	19.0	14.15	58	28.5	33.4	34.5	29.65
28	13.5	18.4	19.5	14.65	59	29.0	33.9	35.0	30.15
29	14.0	18.9	20.0	15.15	60	29.5	34.4	35.5	30.65
30	14.5	19.4	20.5	15.65	61	30.0	34.9	36.0	31.15
31	15.0	19.9	21.0	16.15	62	30.5	35.4	36.5	31.65
32	15.5	20.4	21.5	16.65	63	31.0	35.9	37.0	32.15
33	16.0	20.9	22.0	17.15	64	31.5	36.4	37.5	32.65
34	16.5	21.4	22.5	17.65	65	32.0	36.9	38.0	33.15

REV	REV	REV	REV	REV
H	G	F	E	D
修正L000和標號/PIN端標記與實物相符 (CCN=0803011)	新加PCB LAYOUT尺寸, 1MM (CCN=0706093)	For PIR-AD05028新增黑色 ECN0607099	新增露銅規格 (無鉛筆塗)	
08/03/04	07/06/20	06/07/28	05/2/16	
L11Y	Z.M.D	周本方	鍾林林	
REVISION DESCRIPTION		DATE	SIGNATURE	

一般公差 <b>±0.6</b> <b>XX ±0.16</b> <b>X ±0.25</b> <b>XXX ±0.1</b> ANGLES 1:2		檢驗尺寸標示 <b>SYMBOLS</b> <b>⊕</b> <b>⊖</b> <b>⊗</b> <b>⊙</b> <b>⊚</b> <b>⊛</b> <b>⊜</b> <b>⊝</b> <b>⊞</b> <b>⊟</b> <b>⊠</b> <b>⊡</b> <b>⊢</b> <b>⊣</b> <b>⊤</b> <b>⊥</b> <b>⊦</b> <b>⊧</b> <b>⊨</b> <b>⊩</b> <b>⊪</b> <b>⊫</b> <b>⊬</b> <b>⊭</b> <b>⊮</b> <b>⊯</b> <b>⊰</b> <b>⊱</b> <b>⊲</b> <b>⊳</b> <b>⊴</b> <b>⊵</b> <b>⊶</b> <b>⊷</b> <b>⊸</b> <b>⊹</b> <b>⊺</b> <b>⊻</b> <b>⊼</b> <b>⊽</b> <b>⊾</b> <b>⊿</b> <b>⊠</b> <b>⊡</b> <b>⊢</b> <b>⊣</b> <b>⊤</b> <b>⊥</b> <b>⊦</b> <b>⊧</b> <b>⊨</b> <b>⊩</b> <b>⊪</b> <b>⊫</b> <b>⊬</b> <b>⊭</b> <b>⊮</b> <b>⊯</b> <b>⊰</b> <b>⊱</b> <b>⊲</b> <b>⊳</b> <b>⊴</b> <b>⊵</b> <b>⊶</b> <b>⊷</b> <b>⊸</b> <b>⊹</b> <b>⊺</b> <b>⊻</b> <b>⊼</b> <b>⊽</b> <b>⊾</b> <b>⊿</b>		品名 (TITLE) 圖號 (DRAWING NO) 製圖 (DR) 審核 (CHKD) 核准 (APPD)	
表面處理 (FINISH) <b>⊕ MARK IS CRITICAL DIM.</b> <b>⊖ MARK IS MAJOR DIM.</b>		比例 (SCALE) 單位 (UNITS) 張數 (SHEET) 1 OF 1 SIZE A4 REV H			