

Sheet: /
File: control-panel.sch

Title: Peaktech 6070 Control Panel

Size: A4 Date: 2020-10-16
KiCad E.D.A. kicad 5.1.6+dfsg1-1bpo10+1

Rev:
Id: 1/3

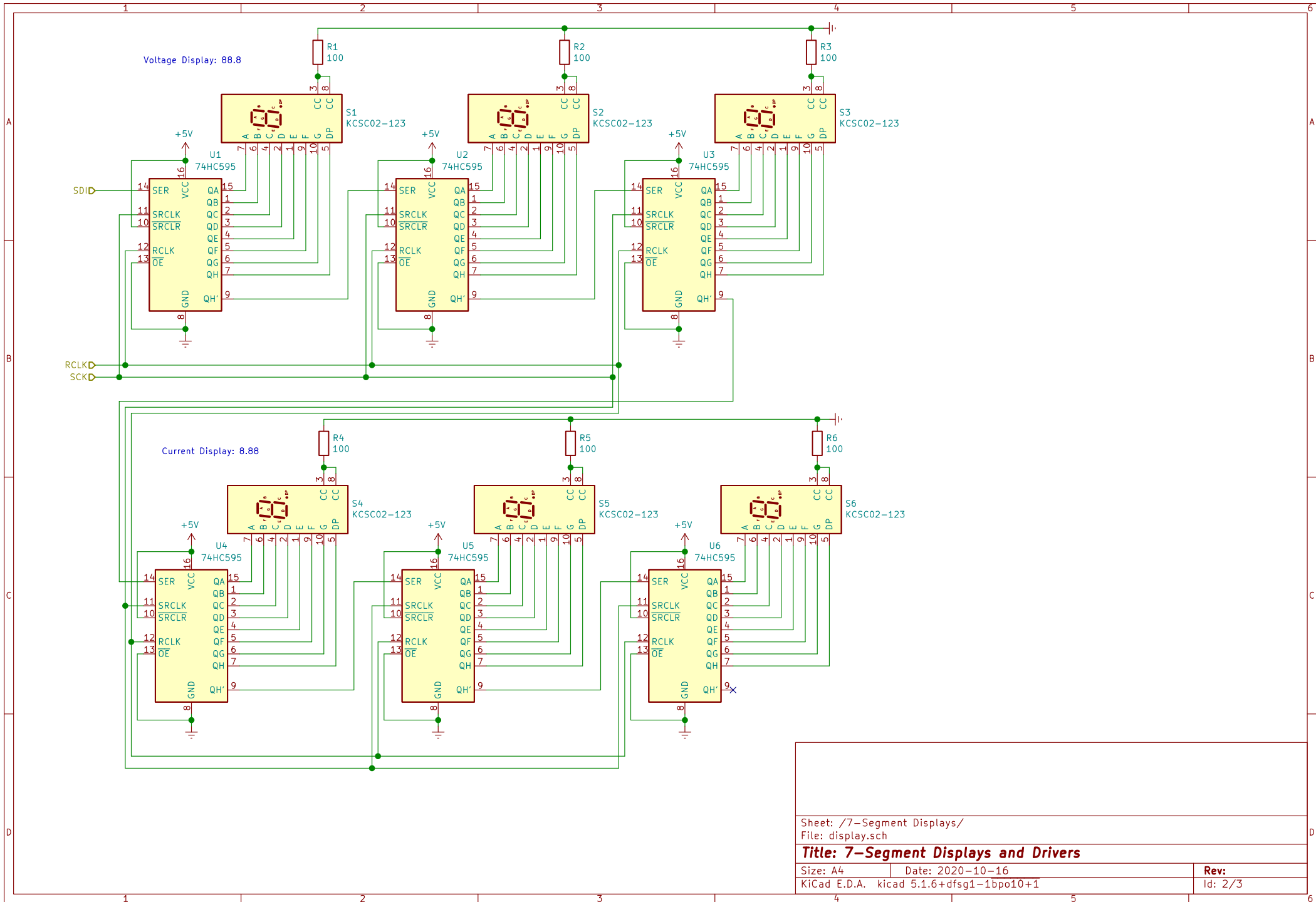

Sheet: /7-Segment Displays/
 File: display.sch

Title: 7-Segment Displays and Drivers

Size: A4 Date: 2020-10-16
 KiCad E.D.A. kicad 5.1.6+dfsg1-1bpo10+1

Rev:
 Id: 2/3

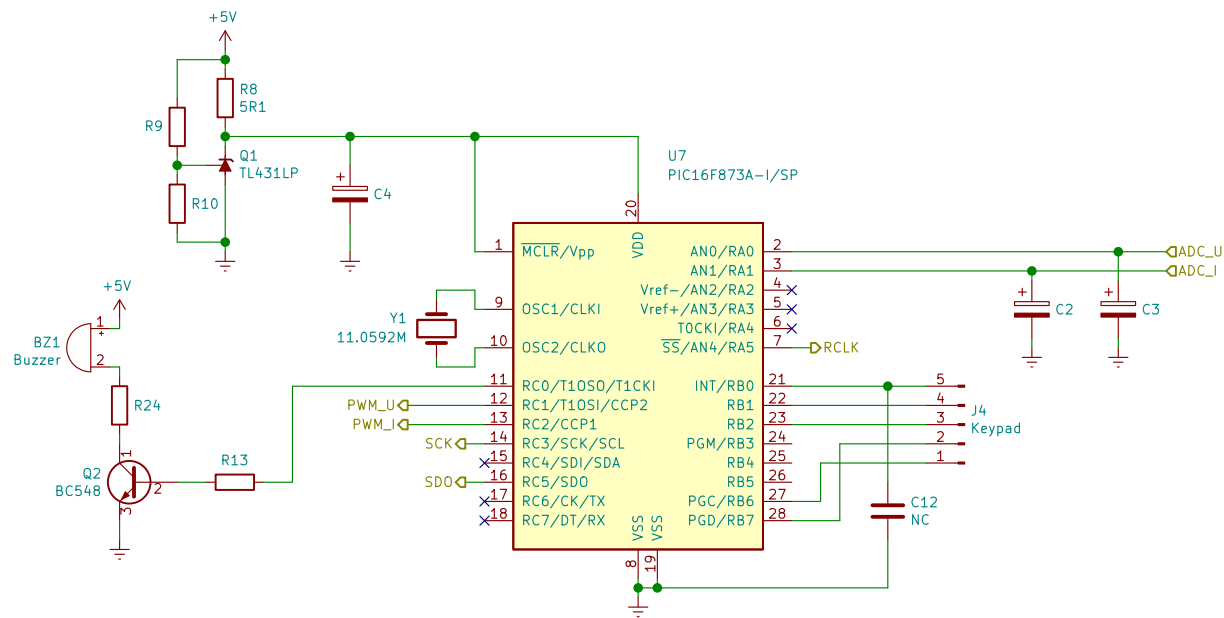

Sheet: / Microcontroller/
File: microcontroller.sch

Title: Microcontroller

Size: A4 Date: 2020-10-16
KiCad E.D.A. kicad 5.1.6+dfsg1-1bpo10+1

Rev:
Id: 3/3