

38120S 10Ah 3,2V 2,0V-3,65V Discharge 100A (10C) Charge 50A (5C) Cycle Life 1500cycles 1C 100%DOD, 2000cycles 1C 80%DOD Charge10- 45GC Discharge Temperature Range: 20-65°C 105Wh/kg Internal Resistance: <6mR Size Diameter: 38mm Length: 120mm (135mm screw)

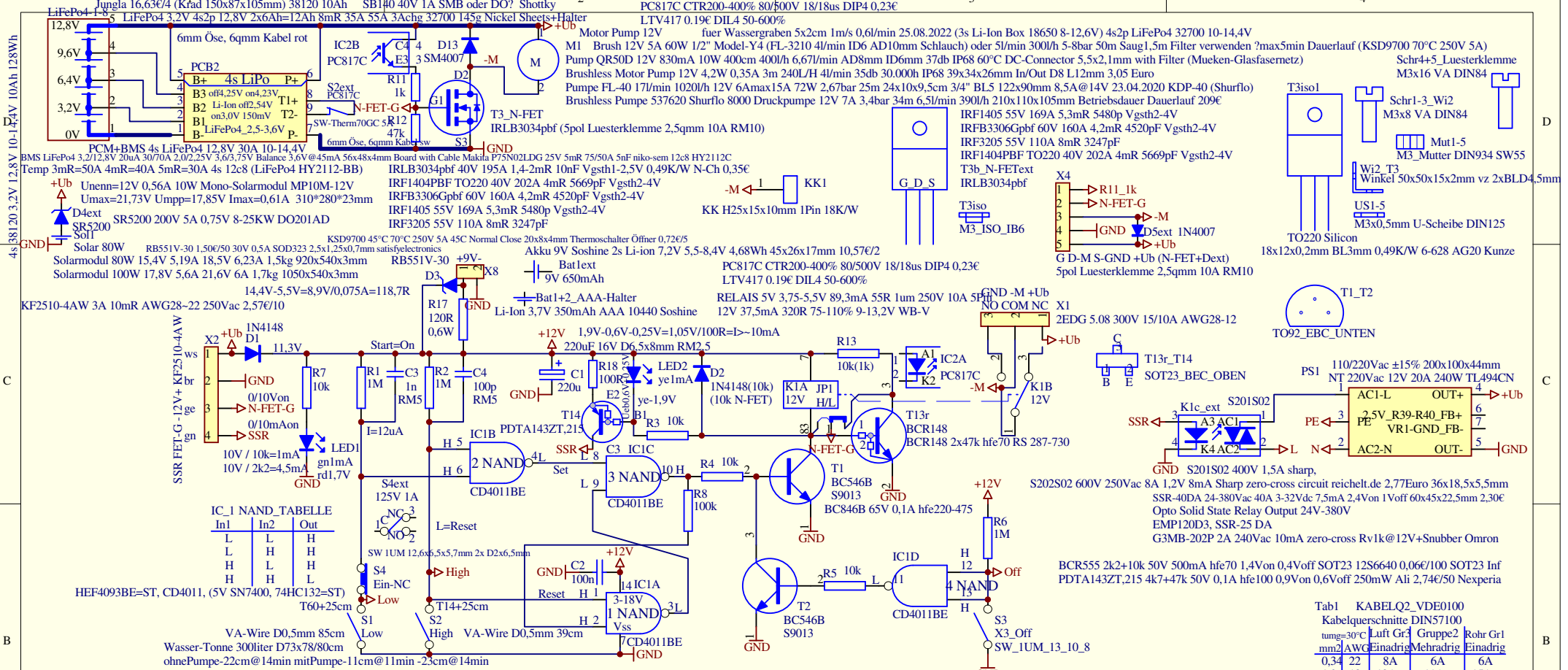

- water_level_V03
- water_level_V03
- PCB Cu 35um 70x50x1,5mm
- X5 S1-S2
- LED1_LED2
- A K LED3_TH_TGEH
- Schr1-4_Geh1
- Blech 2,9x6,5 DIN7981Z
- SBL29065 2,40€/100 Reichelt.de
- X6
- Abstandshalter 2,5qmm 10A RM10

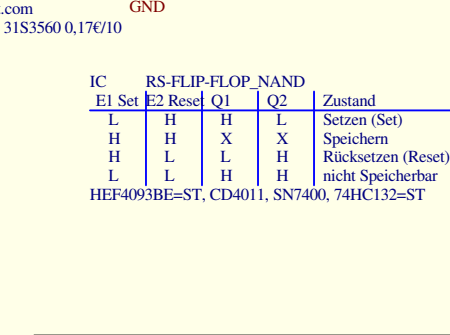
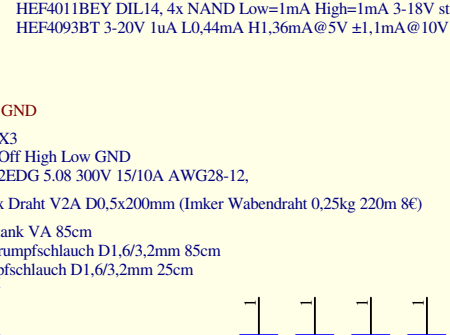
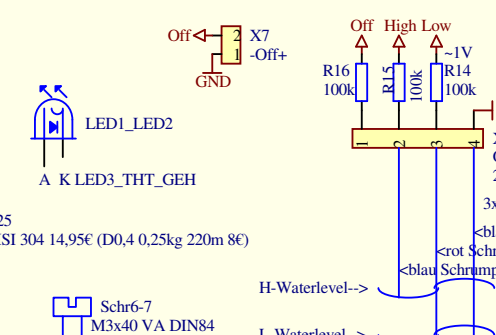

Tab1 KABELQ2_VDE0100
Kabelquerschnitte DIN57100
t_{umg}=30°C Luft Gr3 Gruppe2 Rohr Gr1

mm2	AWG	Einadrig	Mehradrig	Einadrig
0,34	22	8A	6A	6A
1,0	18	19A	11A	15A
1,5	16	24A	15A	18A
2,5	14	32A	20A	26A
4,0	12	42A	25A	34A
6,0	10	54A	33A	44A
10	8	73A	45A	61A

Tab2 KABELQ_VDE0100
Kabelquerschnitte DIN57100
t_{umg}=30°C Luft Gr3 Gruppe2

mm2	AWG	Einadrig	Mehradrig
16	6	98A D6	81A
25	4	129A D8	108A
35	2	158A D9	135A
50	1/0	198A D11,1	168A
70	2/0	245A D12,5	207A
95	3/0	292A D15	250A