

# PE4302

**50  $\Omega$  RF Digital Attenuator**  
**6-bit, 31.5 dB, DC – 4.0 GHz**

### Features

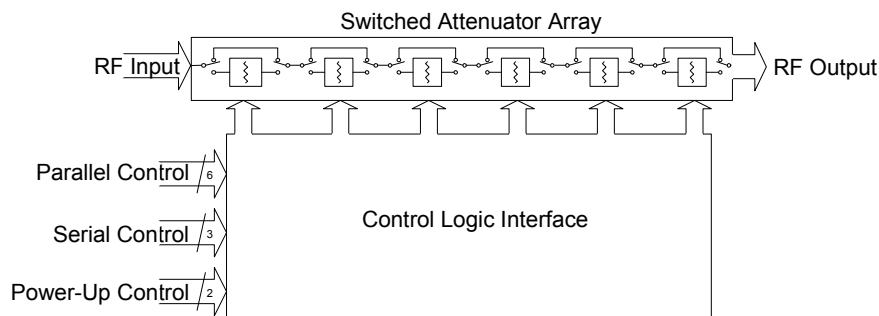
- Attenuation: 0.5 dB steps to 31.5 dB
- Flexible parallel and serial programming interfaces
- Unique power-up state selection
- Positive CMOS control logic
- High attenuation accuracy and linearity over temperature and frequency
- Very low power consumption
- Single-supply operation
- 50  $\Omega$  impedance
- Packaged in a 20 lead 4x4mm QFN

### Product Description

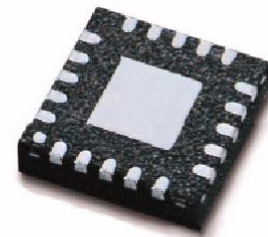
The PE4302 is a high linearity, 6-bit RF Digital Step Attenuator “DSA” covering a 31.5 dB attenuation range in 0.5 dB steps. This 50-ohm RF DSA provides both parallel and serial CMOS control interface operates on a single 3-volt supply and maintains high attenuation accuracy over frequency and temperature. It also has a unique control interface that allows the user to select an initial attenuation state at power-up. The PE4302 exhibits very low insertion loss and low power consumption. This functionality is delivered in a 4x4mm QFN footprint.

The PE4302 is manufactured in Peregrine’s patented Ultra Thin Silicon (UTSi®) CMOS process, offering the performance of GaAs with the economy and integration of conventional CMOS.

**Figure 1. Functional Schematic Diagram**



**Figure 2. Package Type**  
 4x4mm -20 Lead QFN



**Table 1. Electrical Specifications @ +25°C, V<sub>DD</sub> = 3.0 V**

Parameter	Test Conditions	Frequency	Minimum	Typical	Maximum	Units
Operation Frequency			DC		4000	MHz
Insertion Loss <sup>2</sup>		DC - 2.2 GHz	-	1.5	1.75	dB
Attenuation Accuracy	Any Bit or Bit Combination	DC ≤ 1.0 GHz	-	-	±(0.10 + 3% of atten setting)	dB
		1.0 < 2.2 GHz	-	-	±(0.15 + 5% of atten setting)	dB
1 dB Compression <sup>3</sup>		1 MHz - 2.2 GHz	30	34	-	dBm
Input IP <sub>3</sub> <sup>1,2</sup>	Two-tone inputs +18 dBm	1 MHz - 2.2 GHz	-	52	-	dBm
Return Loss		DC - 2.2 GHz	15	20	-	dB
Switching Speed	50% control to 0.5 dB of final value		-	-	1	μs

Notes: 1. Device Linearity will begin to degrade below 1 Mhz

2. See Max input rating in Table 2 & Figures on Pages 2 to 4 for data across frequency.

3. Note Absolute Maximum in Table 3.

Typical Performance Data (25°C,  $V_{DD}=3.0\text{ V}$ )

Figure 3. Insertion Loss

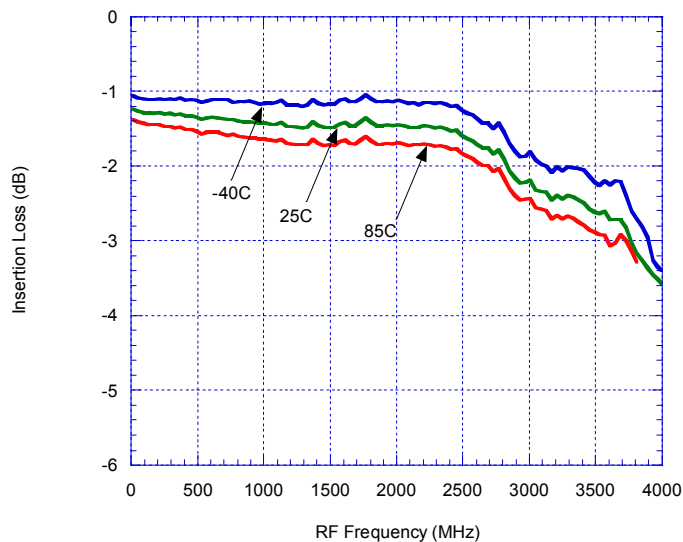


Figure 4. Attenuation at Major steps

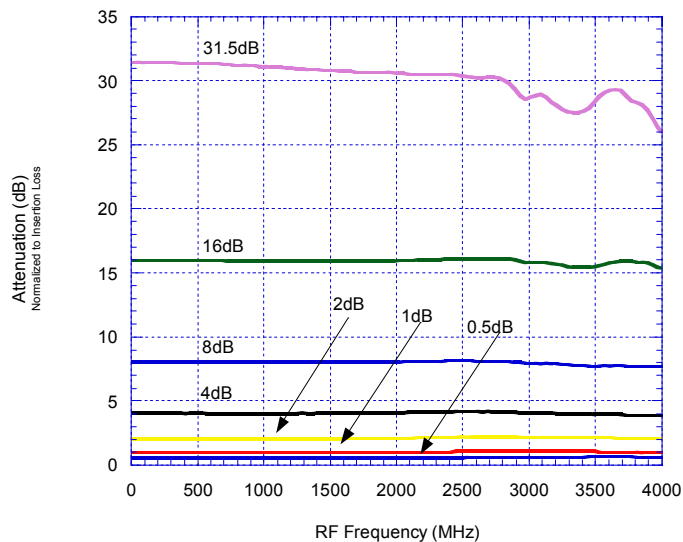


Figure 5. Input Return Loss at Major Attenuation Steps

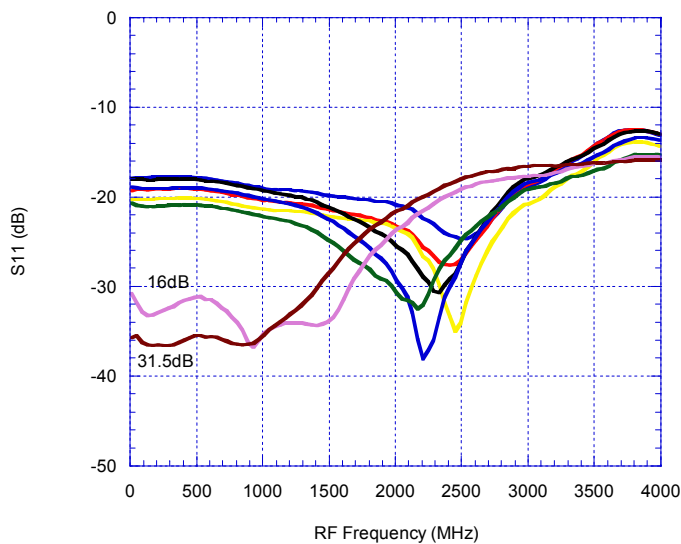
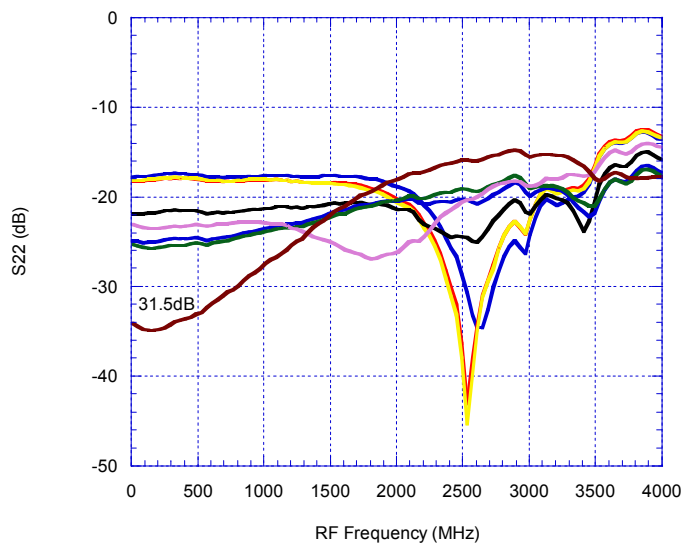


Figure 6. Output Return Loss at Major Attenuation Steps



Typical Performance Data (25°C, V<sub>DD</sub>=3.0 V)

Figure 7. Attenuation Error Vs. Frequency

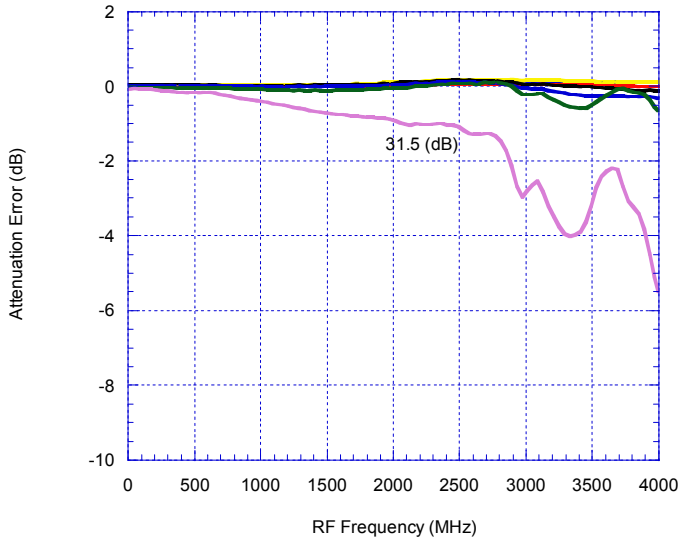


Figure 8. Attenuation Error Vs. Attenuation Setting

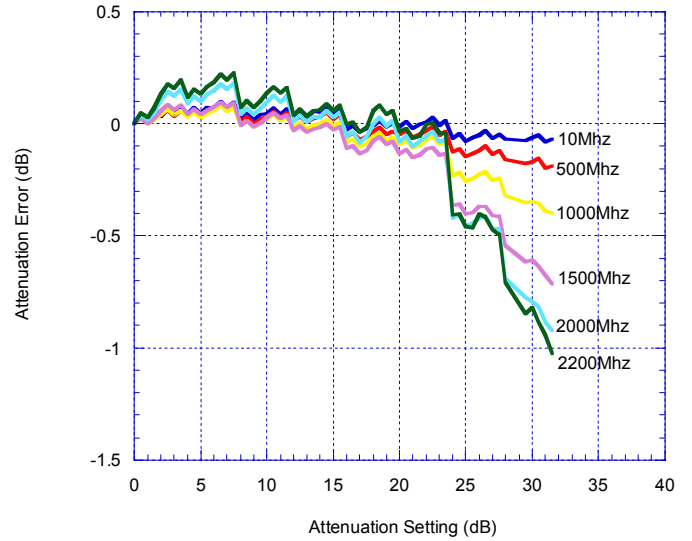


Figure 9. Attenuation Error Vs. Attenuation Setting

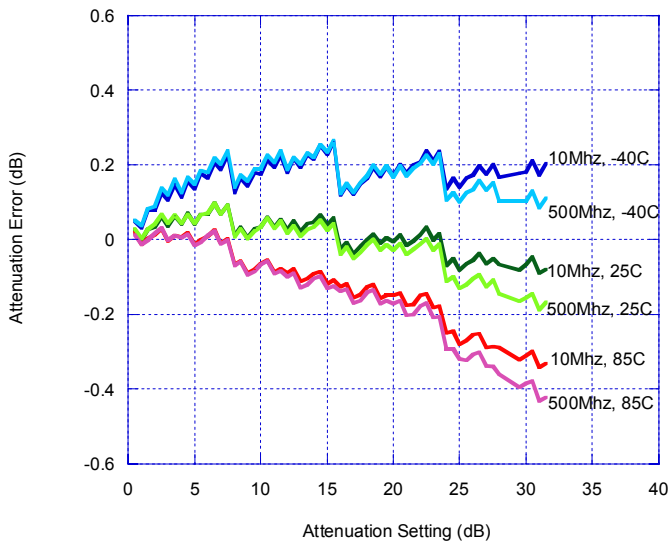
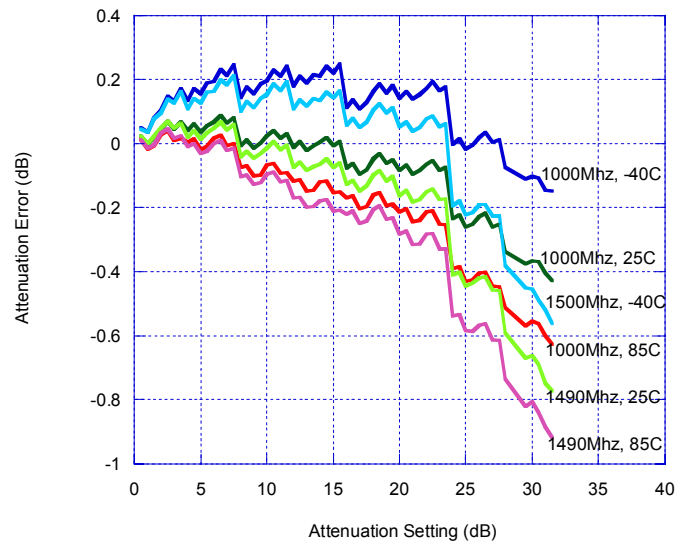


Figure 10. Attenuation Error Vs. Attenuation Setting



Typical Performance Data (25°C, V<sub>DD</sub>=3.0 V)

Figure 11. Attenuation Error Vs. Frequency

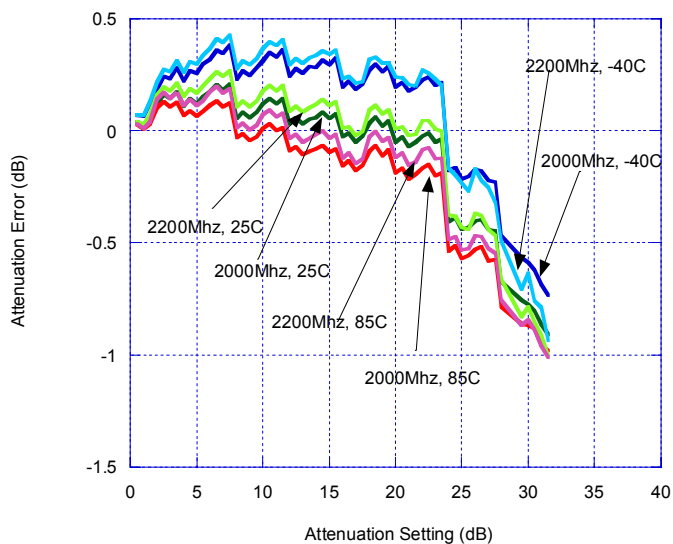


Figure 12. Input IP3 Vs. Frequency

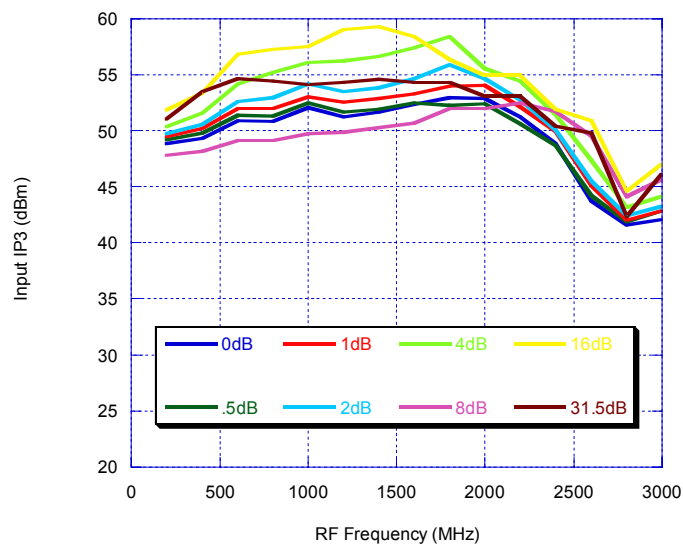


Figure 13. Input 1 dB Compression

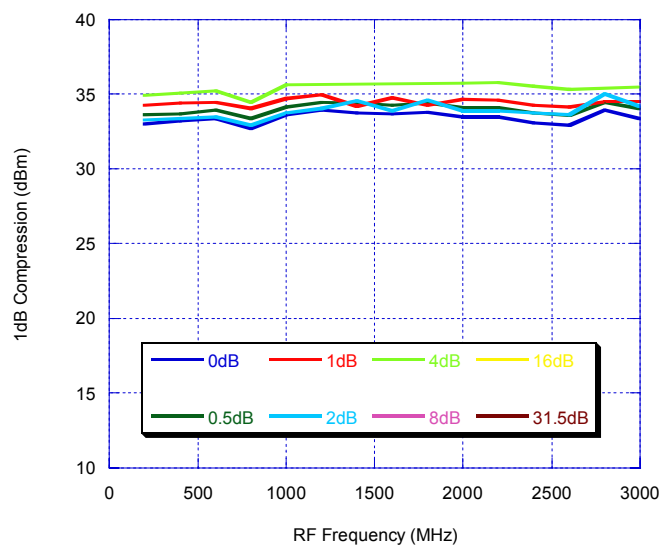


Figure 14. Pin Configuration (Top View)

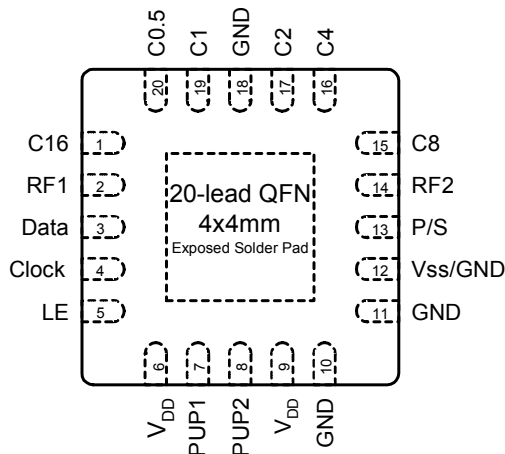


Table 2. Pin Descriptions

Pin No.	Pin Name	Description
1	C16	Attenuation control bit, 16dB (Note 4).
2	RF1	RF port (Note 1).
3	Data	Serial interface data input (Note 4).
4	Clock	Serial interface clock input.
5	LE	Latch Enable input (Note 2).
6	V <sub>DD</sub>	Power supply pin.
7	PUP1	Power-up selection bit, MSB.
8	PUP2	Power-up selection bit, LSB.
9	V <sub>DD</sub>	Power supply pin.
10	GND	Ground connection.
11	GND	Ground connection.
12	V <sub>SS</sub> /GND	Negative supply voltage or GND connection (Note 3)
13	P/S	Parallel/Serial mode select.
14	RF2	RF port (Note 1).
15	C8	Attenuation control bit, 8 dB.
16	C4	Attenuation control bit, 4 dB.
17	C2	Attenuation control bit, 2 dB.
18	GND	Ground connection.
19	C1	Attenuation control bit, 1 dB.
20	C0.5	Attenuation control bit, 0.5 dB.
Paddle	GND	Ground for proper operation

- Note 1: Both RF ports must be held at 0 V<sub>DC</sub> or DC blocked with an external series capacitor.  
 2: Latch Enable (LE) has an internal 100 kΩ resistor to V<sub>DD</sub>.  
 3: Connect pin 12 to GND to enable internal negative voltage generator. Connect pin 12 to V<sub>SS</sub> (-V<sub>DD</sub>) to bypass and disable internal negative voltage generator.  
 4: Place a 10 kΩ resistor in series, as close to pin as possible to avoid frequency resonance.

Table 3. Absolute Maximum Ratings

Symbol	Parameter/Conditions	Min	Max	Units
V <sub>DD</sub>	Power supply voltage	-0.3	4.0	V
V <sub>I</sub>	Voltage on any input	-0.3	V <sub>DD</sub> +0.3	V
T <sub>ST</sub>	Storage temperature range	-65	150	°C
T <sub>OP</sub>	Operating temperature range	-40	85	°C
P <sub>IN</sub>	Input power (50Ω)		24	dBm
V <sub>ESD</sub>	ESD voltage (Human Body Model)		500	V

Table 4. DC Electrical Specifications

Parameter	Min	Typ	Max	Units
V <sub>DD</sub> Power Supply Voltage	2.7	3.0	3.3	V
I <sub>DD</sub> Power Supply Current			100	μA
Digital Input High	0.7xV <sub>DD</sub>			V
Digital Input Low			0.3xV <sub>DD</sub>	V
Digital Input Leakage			1	μA

### Exposed Solder Pad Connection

The exposed solder pad on the bottom of the package must be grounded for proper device operation.

### Electrostatic Discharge (ESD) Precautions

When handling this UltraCMOS™ device, observe the same precautions that you would use with other ESD-sensitive devices. Although this device contains circuitry to protect it from damage due to ESD, precautions should be taken to avoid exceeding the rate specified in Table 3.

### Latch-Up Avoidance

Unlike conventional CMOS devices, UltraCMOS™ devices are immune to latch-up.

### Switching Frequency

The PE4302 has a maximum 25kHz switching rate.

### Resistor on Pin 1 & 3

A 10 kΩ resistor on the inputs to Pin 1 & 3 (see Figure 16) will eliminate package resonance between the RF input pin and the two digital inputs. Specified attenuation error versus frequency performance is dependent upon this condition.

## Programming Options

### Parallel/Serial Selection

Either a parallel or serial interface can be used to control the PE4302. The P/S bit provides this selection, with P/S=LOW selecting the parallel interface and P/S=HIGH selecting the serial interface.

### Parallel Mode Interface

The parallel interface consists of five CMOS-compatible control lines that select the desired attenuation state, as shown in Table 5.

The parallel interface timing requirements are defined by Figure 18 (Parallel Interface Timing Diagram), Table 9 (Parallel Interface AC Characteristics), and switching speed (Table 1).

For *latched* parallel programming the Latch Enable (LE) should be held LOW while changing attenuation state control values, then pulse LE HIGH to LOW (per Figure 18) to latch new attenuation state into device.

For *direct* parallel programming, the Latch Enable (LE) line should be pulled HIGH. Changing attenuation state control values will change device state to new attenuation. Direct Mode is ideal for manual control of the device (using hardware, switches, or jumpers).

**Table 5. Truth Table**

P/S	C16	C8	C4	C2	C1	C0.5	Attenuation State
0	0	0	0	0	0	0	Reference Loss
0	0	0	0	0	0	1	0.5 dB
0	0	0	0	0	1	0	1 dB
0	0	0	0	1	0	0	2 dB
0	0	0	1	0	0	0	4 dB
0	0	1	0	0	0	0	8 dB
0	1	0	0	0	0	0	16 dB
0	1	1	1	1	1	1	31.5 dB

Note: Not all 64 possible combinations of C0.5-C16 are shown in table

### Serial Interface

The serial interface is a 6-bit serial-in, parallel-out shift register buffered by a transparent latch. It is controlled by three CMOS-compatible signals: Data,

Clock, and Latch Enable (LE). The Data and Clock inputs allow data to be serially entered into the shift register, a process that is independent of the state of the LE input.

The LE input controls the latch. When LE is HIGH, the latch is transparent and the contents of the serial shift register control the attenuator. When LE is brought LOW, data in the shift register is latched.

The shift register should be loaded while LE is held LOW to prevent the attenuator value from changing as data is entered. The LE input should then be toggled HIGH and brought LOW again, latching the new data. The timing for this operation is defined by Figure 17 (Serial Interface Timing Diagram) and Table 8 (Serial Interface AC Characteristics).

### Power-up Control Settings

The PE4302 always assumes a specifiable attenuation setting on power-up. This feature exists for both the Serial and Parallel modes of operation, and allows a known attenuation state to be established before an initial serial or parallel control word is provided.

When the attenuator powers up in Serial mode (P/S=1), the six control bits are set to whatever data is present on the six parallel data inputs (C0.5 to C16). This allows any one of the 64 attenuation settings to be specified as the power-up state.

When the attenuator powers up in Parallel mode (P/S=0) with LE=0, the control bits are automatically set to one of four possible values. These four values are selected by the two power-up control bits, PUP1 and PUP2, as shown in Table 6 (Power-Up Truth Table, Parallel Mode).

**Table 6. Parallel PUP Truth Table**

P/S	LE	PUP2	PUP1	Attenuation State
0	0	0	0	Reference Loss
0	0	1	0	8 dB
0	0	0	1	16 dB
0	0	1	1	31 dB
0	1	X	X	Defined by <b>C0.5-C16</b>

Note: Power up with LE=1 provides normal parallel operation with C0.5-C16, and PUP1 and PUP2 are not active.

## Evaluation Kit

The Digital Attenuator Evaluation Kit board was designed to ease customer evaluation of the PE4302 Digital Step Attenuator.

J9 is used in conjunction with the supplied DC cable to supply VDD, GND, and -VDD. If use of the internal negative voltage generator is desired, then connect -VDD (Black banana plug) to ground. If an external -VDD is desired, then apply -3V.

J1 should be connected to the parallel port of a PC with the supplied ribbon cable. The evaluation software is written to operate the DSA in serial mode, so Switch 7 (P/S) on the DIP switch SW1 should be ON with all other switches off. Using the software, enable or disable each attenuation setting to the desired combined attenuation. The software automatically programs the DSA each time an attenuation state is enabled or disabled.

To evaluate the Power Up options, first disconnect the parallel ribbon cable from the evaluation board. The parallel cable must be removed to prevent the PC parallel port from biasing the control pins.

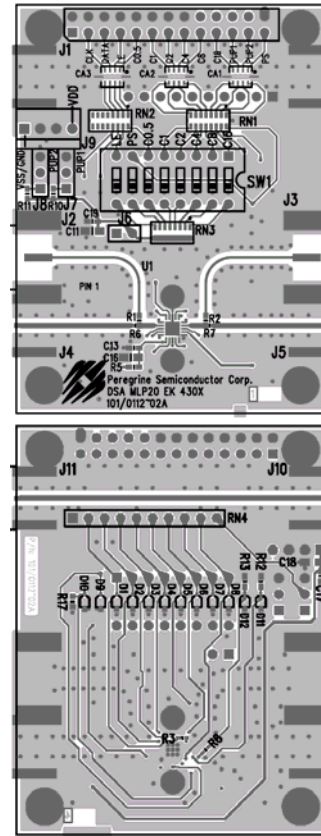
During power up with P/S=1 high and LE=0 or P/S=0 low and LE=1, the default power-up signal attenuation is set to the value present on the six control bits on the six parallel data inputs (C0.5 to C16). This allows any one of the 64 attenuation settings to be specified as the power-up state.

During power up with P/S=0 high and LE=0, the control bits are automatically set to one of four possible values presented through the PUP interface. These four values are selected by the two power-up control bits, PUP1 and PUP2, as shown in the Table 6.

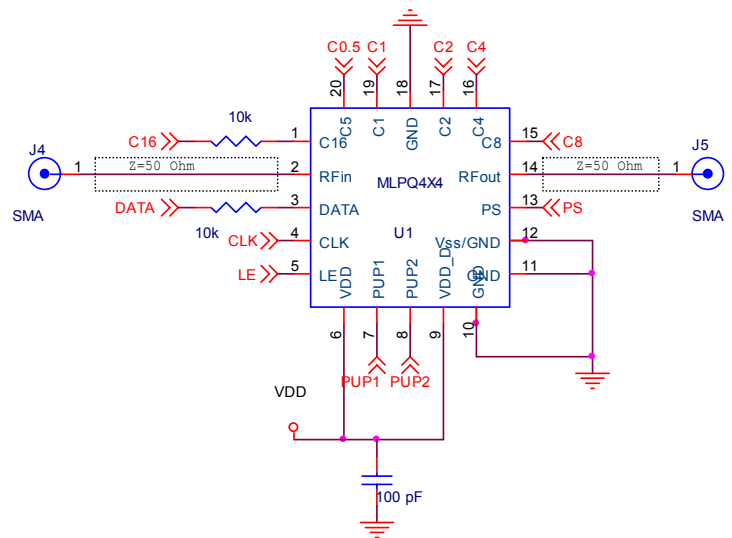
### Resistor on Pin 1 & 3

A 10 kΩ resistor on the inputs to Pin 1 & 3 (Figure 16) will eliminate package resonance between the RF input pin and the two digital inputs. Specified attenuation error versus frequency performance is dependent upon this condition.

**Figure 15. Evaluation Board Layout**



**Figure 16. Evaluation Board Schematic**



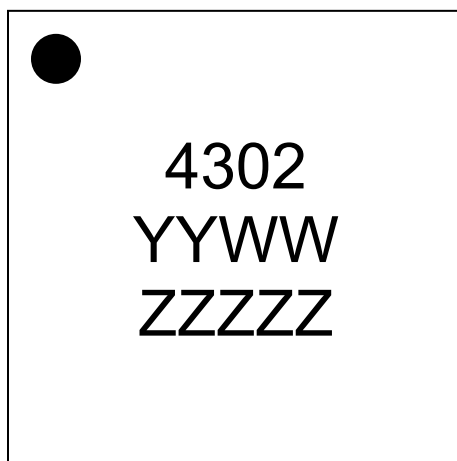
Note: Resistors on pins 1 and 3 are required to avoid package resonance and meet error specifications over frequency.





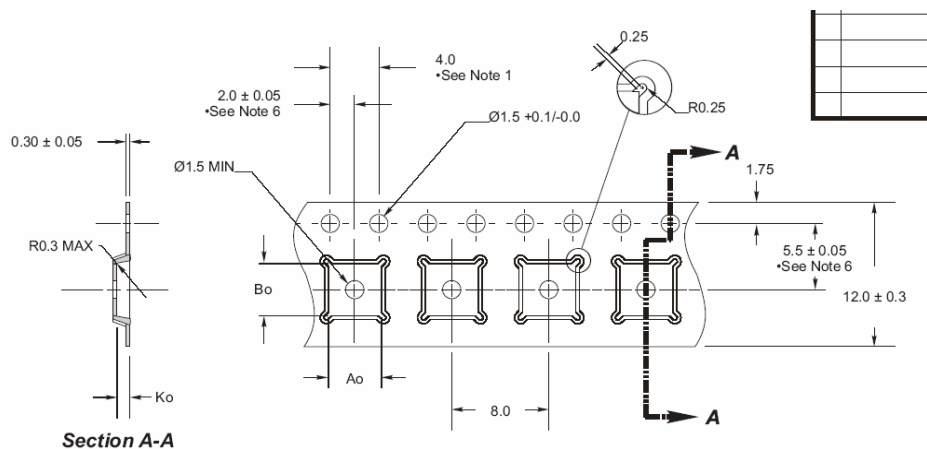


Figure 20. Marking Specifications



YYWW = Date Code  
ZZZZZ = Last five digits of PSC Lot Number

Figure 21. Tape and Reel Drawing



Ao = 4.35 mm  
Bo = 4.35 mm  
Ko = 1.1 mm

- Notes:
1. 10 sprocket hole pitch cumulative tolerance  $\pm 0.2$ .
  2. Camber not to exceed 1mm in 100mm.
  3. Material: PS + C.
  4. Ao and Bo measured as indicated.
  5. Ko measured from a plane on the inside bottom of the pocket to the top surface of the carrier.
  6. Pocket position relative to sprocket hole measured as true position of pocket, not pocket hole.

Table 10. Ordering Information

Order Code	Part Marking	Description	Package	Shipping Method
4302-01	4302	PE4302-20MLP 4x4mm-75A	20-lead 4x4mm QFN	75 units / Tube
4302-02	4302	PE4302-20MLP 4x4mm-3000C	20-lead 4x4mm QFN	3000 units / T&R
4302-00	PE4302-EK	PE4302-20MLP 4x4mm-EK	Evaluation Kit	1 / Box
4302-51	4302	PE4302G-20MLP 4x4mm-75A	Green 20-lead 4x4mm QFN	75 units / Tube
4302-52	4302	PE4302G-20MLP 4x4mm-3000C	Green 20-lead 4x4mm QFN	3000 units / T&R

## Sales Offices

### **United States**

#### **Peregrine Semiconductor Corp.**

9450 Carroll Park Drive  
San Diego, CA 92121  
Tel 1-858-731-9400  
Fax 1-858-731-9499

### **Japan**

#### **Peregrine Semiconductor K.K.**

5A-5, 5F Imperial Tower  
1-1-1 Uchisaiwaicho, Chiyoda-ku  
Tokyo 100-0011 Japan  
Tel: 011-81-3-3502-5211  
Fax: 011-81-3-3502-5213

### **Europe**

#### **Peregrine Semiconductor Europe**

Bâtiment Maine  
13-15 rue des Quatre Vents  
F- 92380 Garches, France  
Tel: 011- 33-1-47-41-91-73  
Fax : 011-33-1-47-41-91-73

### **China**

#### **Peregrine Semiconductor**

28G, Times Square,  
No. 500 Zhangyang Road,  
Shanghai, 200122, P.R. China  
Tel: 011-86-21-5836-8276  
Fax: 011-86-21-5836-7652

For a list of representatives in your area, please refer to our Web site at: [www.psemi.com](http://www.psemi.com)

## Data Sheet Identification

### **Advance Information**

The product is in a formative or design stage. The data sheet contains design target specifications for product development. Specifications and features may change in any manner without notice.

### **Preliminary Specification**

The data sheet contains preliminary data. Additional data may be added at a later date. Peregrine reserves the right to change specifications at any time without notice in order to supply the best possible product.

### **Product Specification**

The data sheet contains final data. In the event Peregrine decides to change the specifications, Peregrine will notify customers of the intended changes by issuing a DCN (Document Change Notice).

The information in this data sheet is believed to be reliable. However, Peregrine assumes no liability for the use of this information. Use shall be entirely at the user's own risk.

No patent rights or licenses to any circuits described in this data sheet are implied or granted to any third party.

Peregrine's products are not designed or intended for use in devices or systems intended for surgical implant, or in other applications intended to support or sustain life, or in any application in which the failure of the Peregrine product could create a situation in which personal injury or death might occur. Peregrine assumes no liability for damages, including consequential or incidental damages, arising out of the use of its products in such applications.

The Peregrine name, logo, and UTSi are registered trademarks and UltraCMOS is a trademark of Peregrine Semiconductor Corp.

This datasheet has been downloaded from:

[www.DatasheetCatalog.com](http://www.DatasheetCatalog.com)

Datasheets for electronic components.