

PIN TERMINAL TYPE

PS12 TYPE

PS1240P02BT

FEATURES

- Miniature size($\phi 12.2 \times T6.5$ mm).
- High cost performance.
- Suitable for automatic radial taping machine(12.7mm-pitch).

SHAPES AND DIMENSIONS

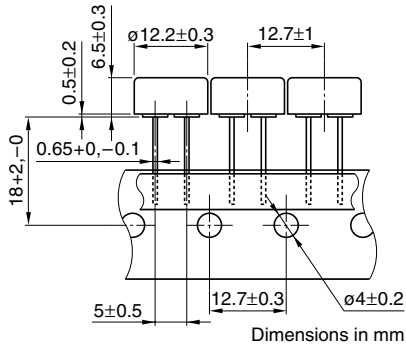

SPECIFICATIONS AND CHARACTERISTICS

Sound pressure	70dBA/ 10cm min.	[at 4kHz, 3V _{0-P} rectangular wave, measuring temperature: 25±5°C, humidity: 60±10%]
Temperature range	Operating -20 to +70°C Storage -30 to +80°C	
Maximum input voltage	30V _{0-P} max.	[without DC bias]
Minimum delivery unit	2500 pieces	[500 pieces/1 reel×5 reels]

FREQUENCY SOUND PRESSURE CHARACTERISTICS

SINE WAVE DRIVE

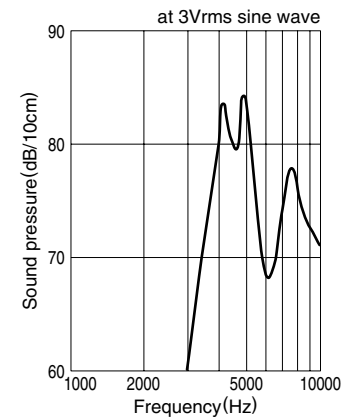

SQUARE WAVE DRIVE

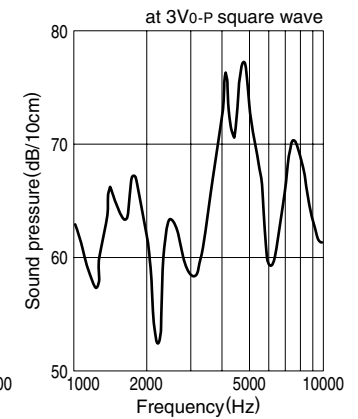

PS1240P02CT3

FEATURES

- Thin type($\phi 12.2 \times T3.5$ mm).
- Suitable for automatic radial taping machine(12.7mm-pitch).

SHAPES AND DIMENSIONS

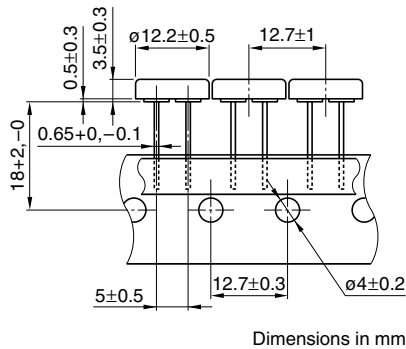

SPECIFICATIONS AND CHARACTERISTICS

Sound pressure	60dBA/ 10cm min.	[at 4kHz, 3V _{0-P} rectangular wave, measuring temperature: 25±5°C, humidity: 60±10%]
Temperature range	Operating -20 to +70°C Storage -30 to +80°C	
Maximum input voltage	30V _{0-P} max.	[without DC bias]
Minimum delivery unit	2500 pieces	[500 pieces/1 reel×5 reels]

FREQUENCY SOUND PRESSURE CHARACTERISTICS

SINE WAVE DRIVE

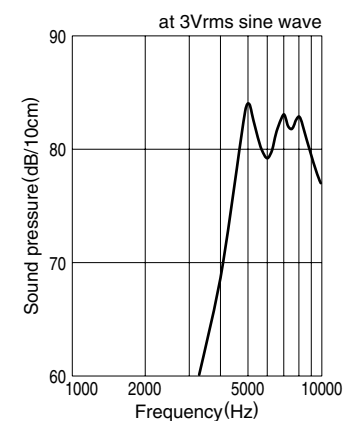

SQUARE WAVE DRIVE

