

UMC/UPC MULTI-SPEED GLANDLESS IN-LINE CIRCULATORS

For water circulation in commercial heating applications.

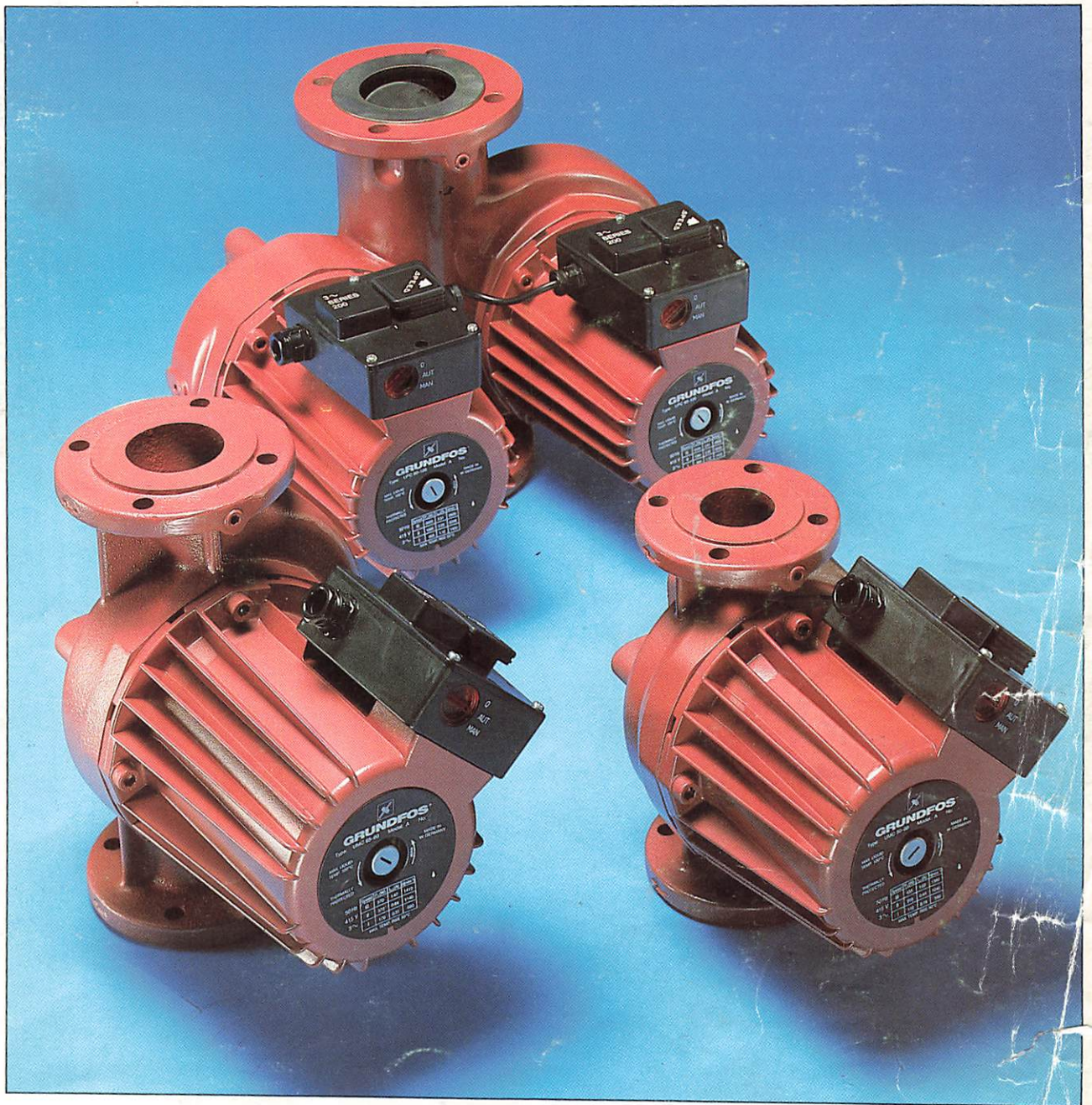

GRUNDFOS 

SERIES 200 MULTI-SPEED NOW EVEN EASIER TO INSTALL AND EASIER TO CONTROL

- * ENERGY SAVING THREE SPEED MOTOR.
- * BUILT-IN OVERLOAD PROTECTION.
- * BUILT-IN CHANGEOVER ON PUMP FAILURE FOR ALL TWIN HEAD MODELS.
- * SUPERB MATERIAL SPECIFICATION.
- * GLANDLESS HEATING CIRCULATORS FOR PIPELINE MOUNTING.
- * FLOWS UP TO 25 L/SEC.
- * PRESSURES UP TO 105 KN/M².
- * MAXIMUM SYSTEM PRESSURE 6 BARS.
- * WATER TEMPERATURES UP TO 120°C.
- * PUMP HOUSING FLANGED TO BS4504 1969 TABLE 6/11.
- * SCREWED BOSS COUNTER FLANGES, BOLTS AND GASKETS INCLUDED.
- * NINE SINGLE AND TWIN HEAD MODELS FOR THREE PHASE OPERATION.
- * SIX SINGLE AND TWIN HEAD MODELS FOR SINGLE PHASE OPERATION.
- * FLAP VALVE FITTED AS STANDARD ON ALL TWIN HEAD MODELS.
- * UPC40 MODELS WITH 2" BSP FLANGES ARE 4 BAR ONLY.

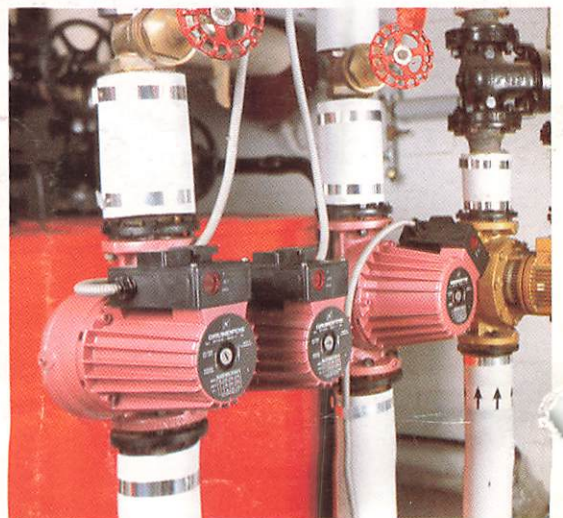
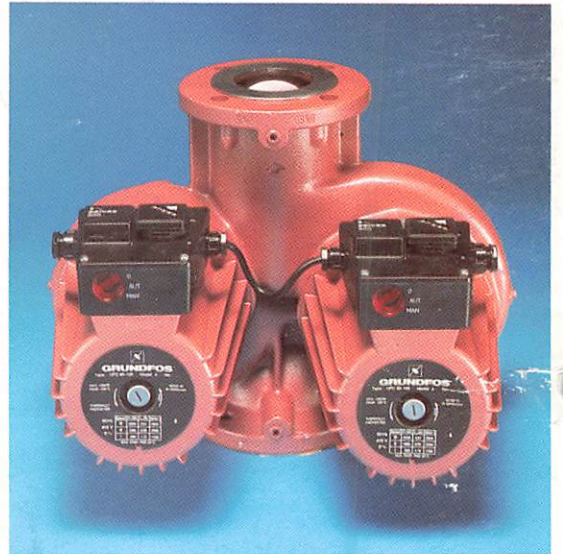

TOTAL CONTROL WITH ENERGY SAVING

Grundfos Multispeed Commercial Heating Circulators have now been further developed to simplify installation and operation. The pump's head incorporates significant advances in electronic control to make this range not only energy efficient, but even easier to install and to operate.

THREE SPEED MOTOR WITH INSTANT SWITCHING

Every Multispeed Circulator incorporates three duty ranges and these can be changed manually by lifting and rotating the speed selector plug; or automatically when controlled remotely. When used in conjunction with appropriate controls, Multispeed saves energy by tailoring motor speed to system requirements. Fluctuations in ambient temperature can account for increasingly high running costs in heating systems. This is where Multispeed's three speed duty range really saves energy. For example model UPC80-120 requires 2020 watts input at speed 3, 1385 watts at speed 2 and only 665 watts on speed 1 – a reduction in power consumption of over 65%.

BUILT-IN MOTOR PROTECTION

In addition to ON/OFF, MANUAL AND AUTOMATIC switching provided on the terminal box cover, we have incorporated a heat sensing overload switch in the motor terminal block, thus protecting the motor against burn-out. Resetting the motor can then be carried out manually or automatically as required. This facility thus eliminates the need for additional external protection, and simplifies electrical installation.

SUPERB STAINLESS STEEL COMPONENTS

As you would expect, Grundfos use only the best materials for vital pump components, like corrosion resistant stainless steel for impeller, rotor can and rotor cladding, hard wearing ceramics for pump bearings. Every pump is tested for smooth quiet operating under simulated working conditions at 90°C, and is guaranteed for twelve months.

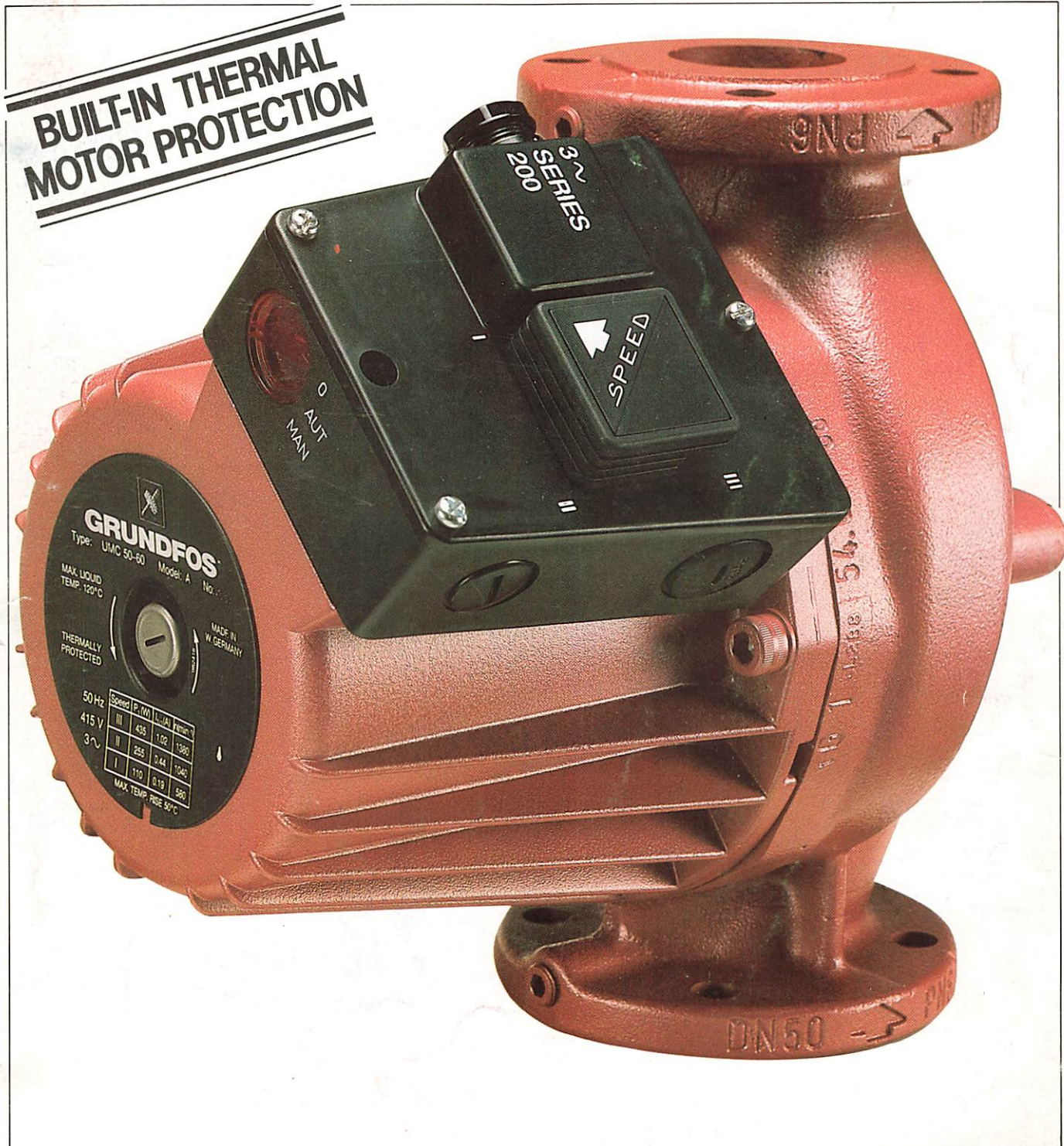

PERFORMANCE RANGE

SINGLE HEAD MODELS

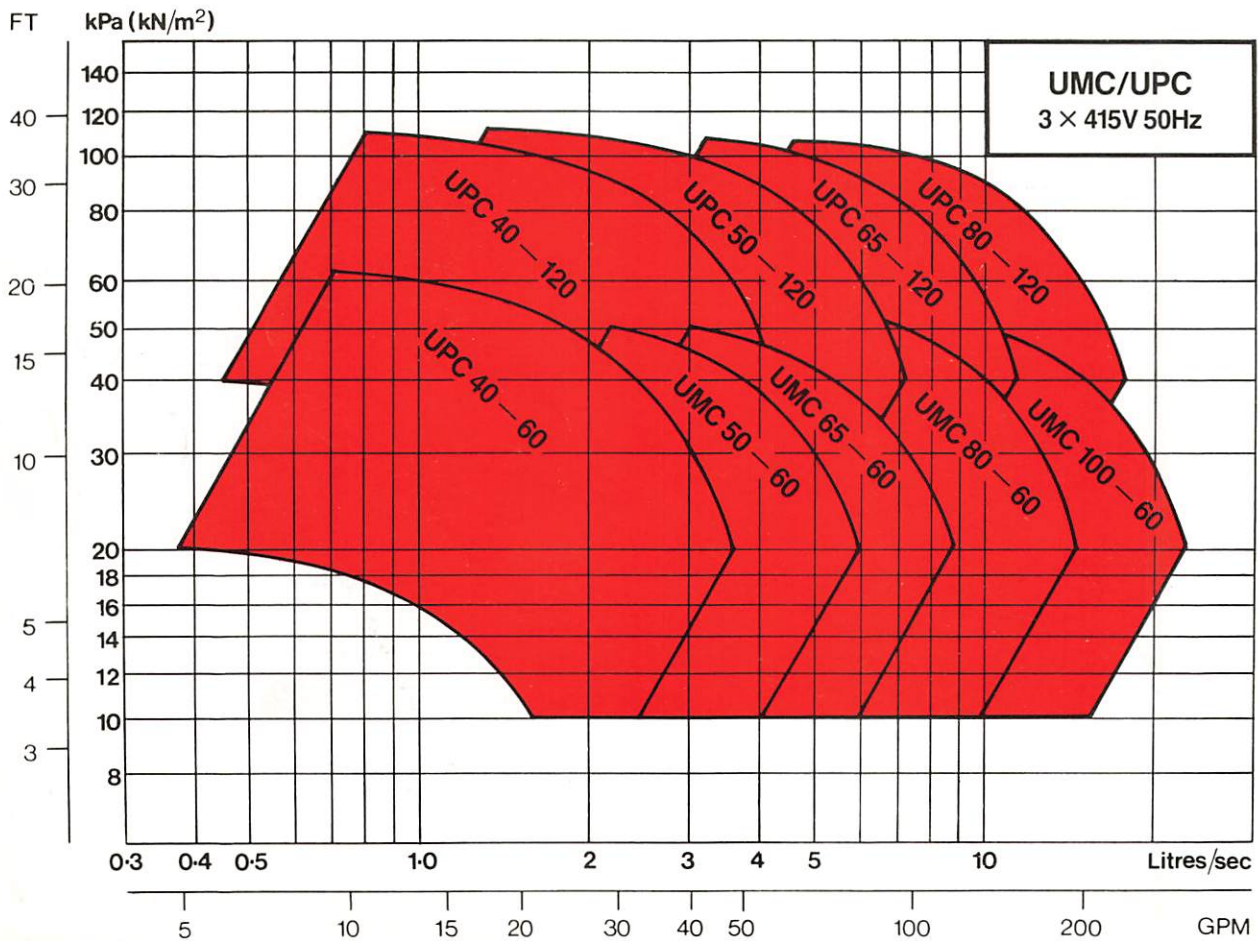
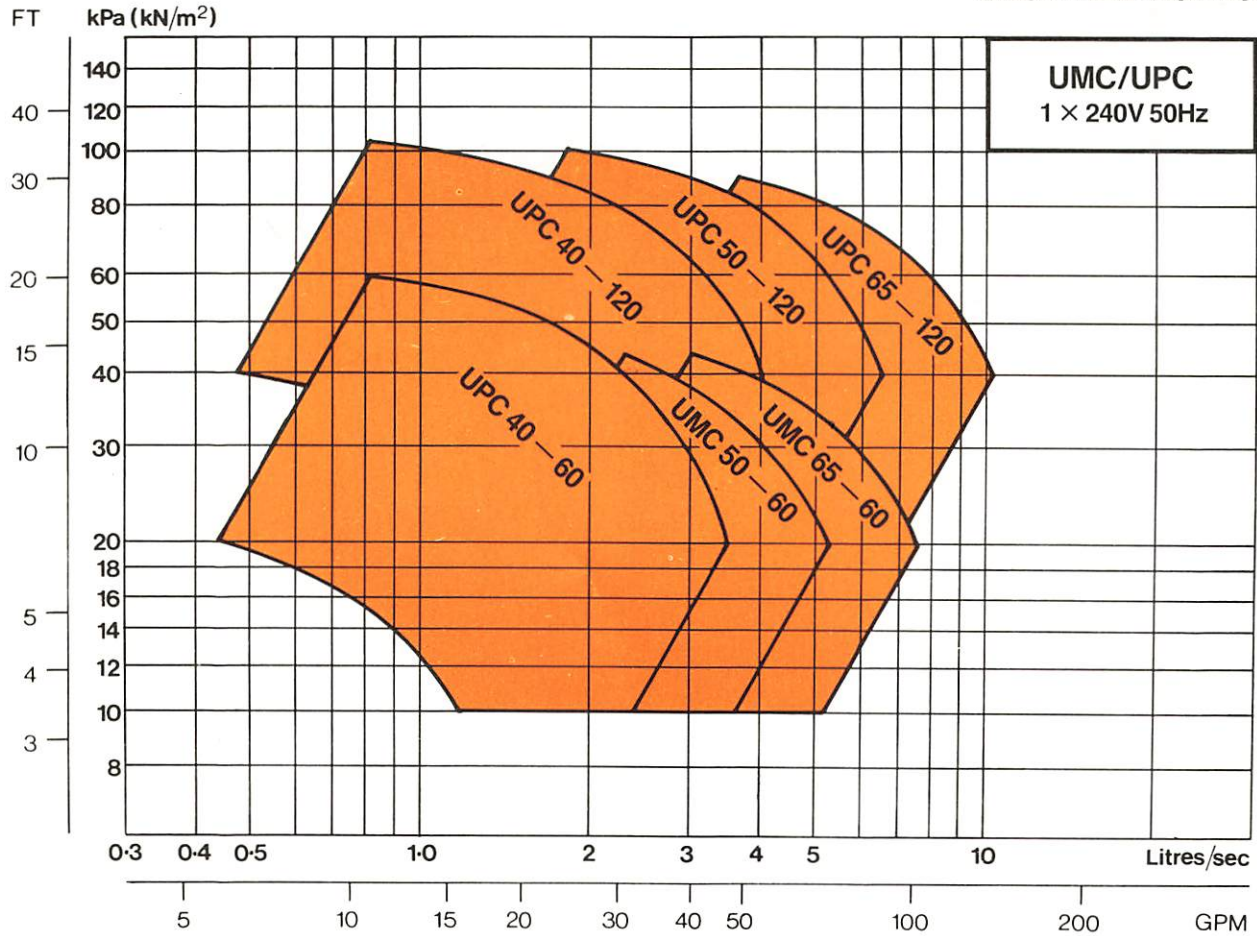

PERFORMANCE RANGE

TWIN HEAD MODELS (ONE HEAD OPERATING)

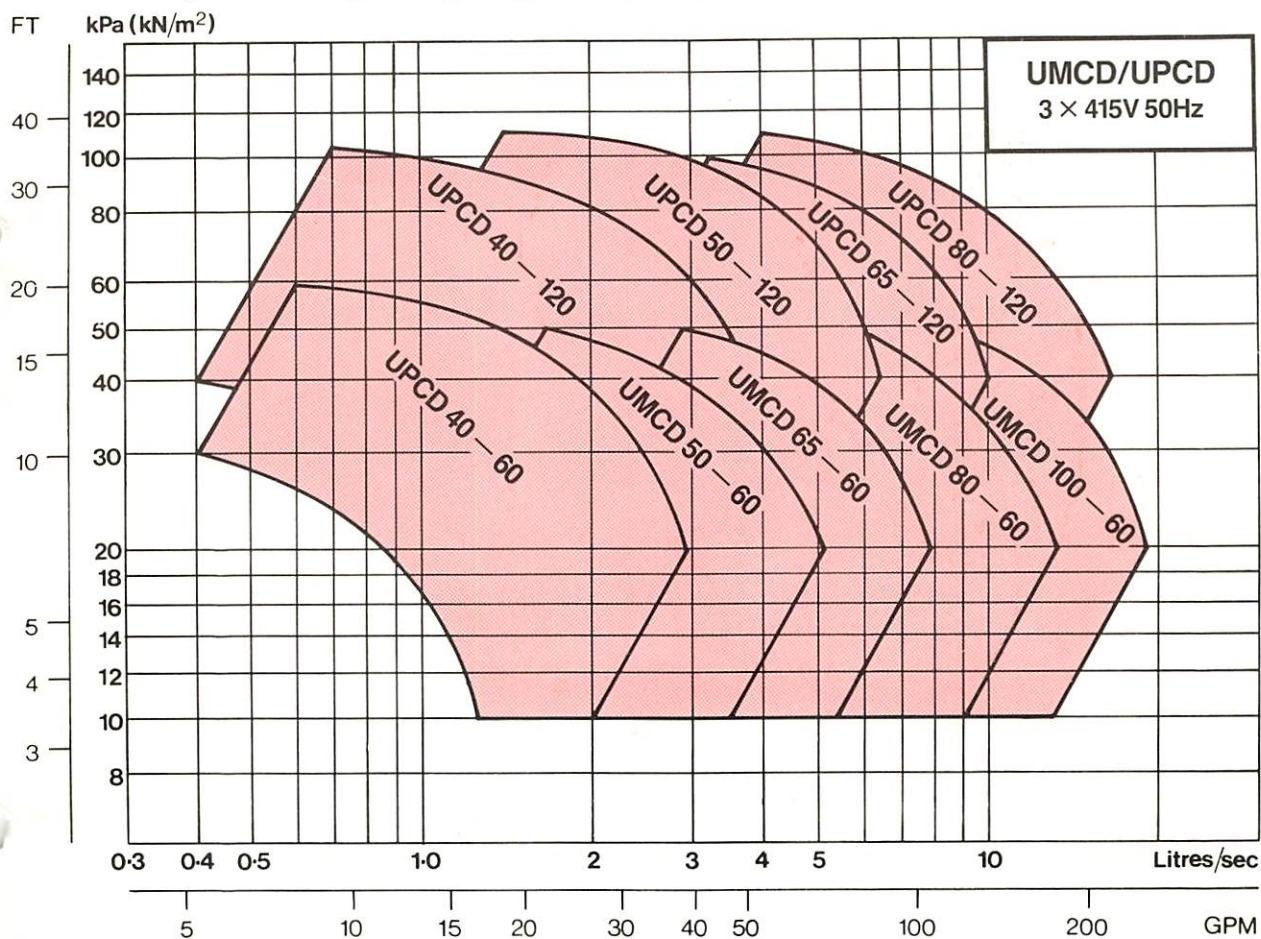
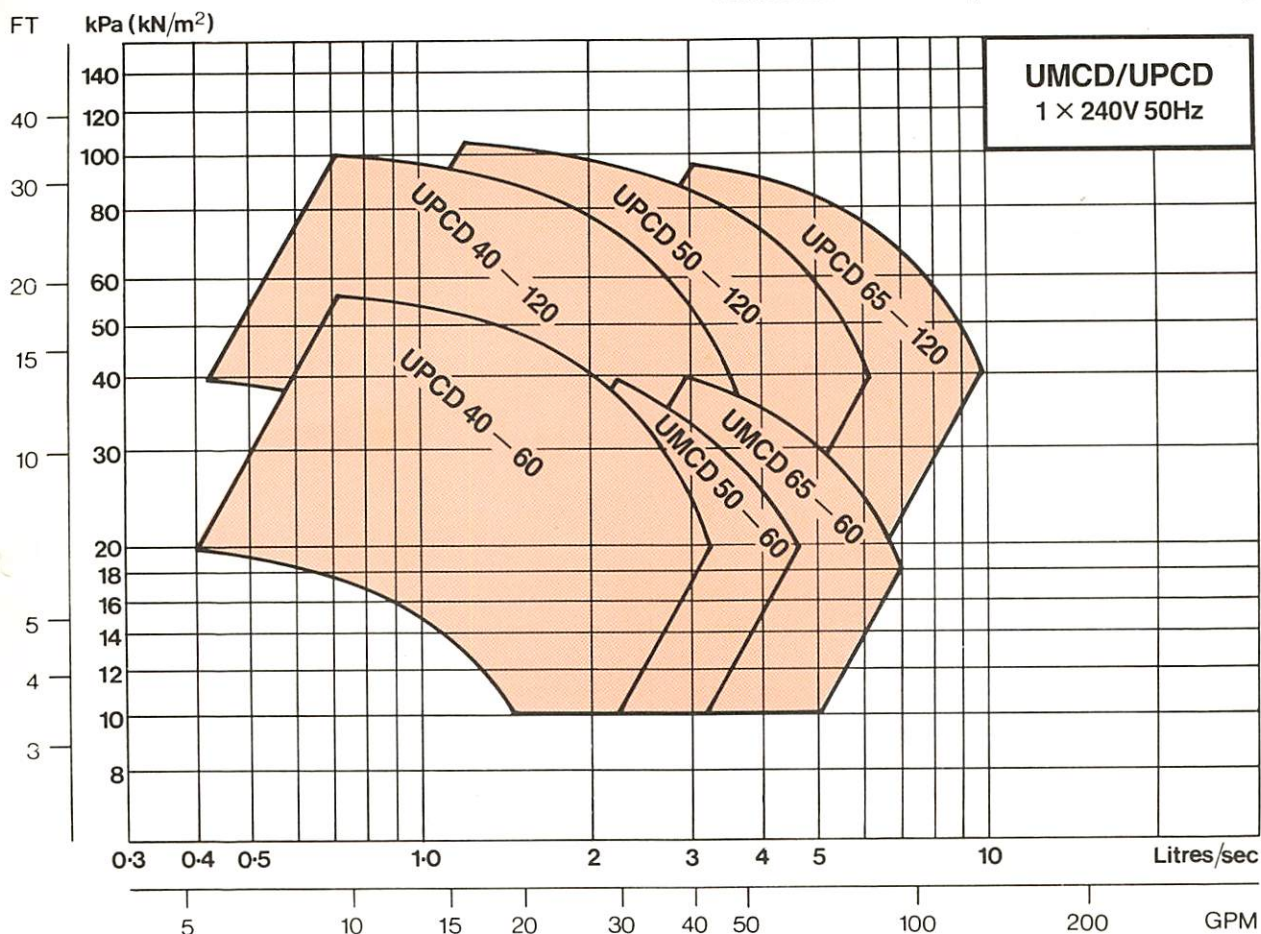

SINGLE HEAD MODELS 1 × 240V 50Hz

ELECTRICAL DATA

| Speed | R.P.M. | Input Power Watts | Full Load Current Amps 1 x 240V | Capacitor Rating |
|-------|--------|-------------------|---------------------------------|------------------|
| ③ | 2710 | 265 | 1.09 | 6 μ F |
| ② | 2250 | 260 | 1.17 | 6 μ F |
| ① | 1780 | 230 | 1.04 | 6 μ F |

Maximum permissible power consumption:
All models are suitable for the values shown plus 10% overload.

Pump selection should be within the shaded area for optimum performance.

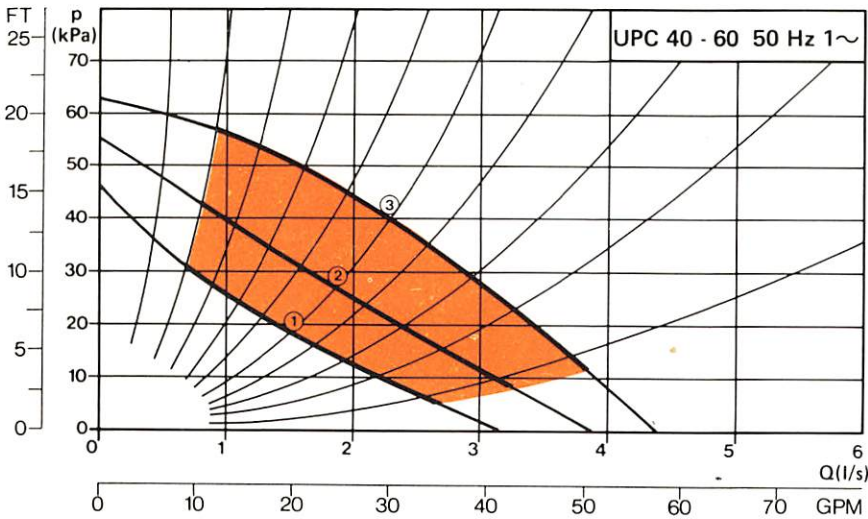

ELECTRICAL DATA

| Speed | R.P.M. | Input Power Watts | Full Load Current Amps 1 x 240V | Capacitor Rating |
|-------|--------|-------------------|---------------------------------|------------------|
| ③ | 2700 | 535 | 2.29 | 10 μ F |
| ② | 2090 | 545 | 2.48 | 10 μ F |
| ① | 1560 | 455 | 2.10 | 10 μ F |

Maximum permissible power consumption:
All models are suitable for the values shown plus 10% overload.

Pump selection should be within the shaded area for optimum performance.

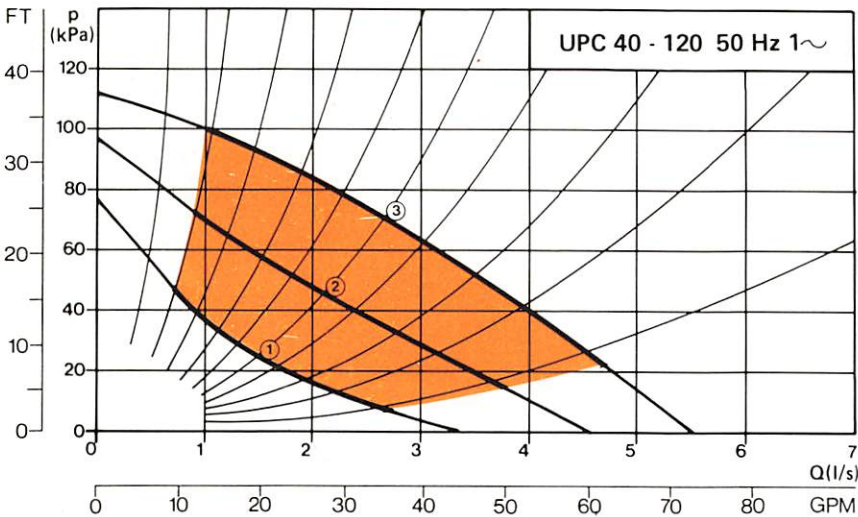

ELECTRICAL DATA

| Speed | R.P.M. | Input Power Watts | Full Load Current Amps 1 x 240V | Capacitor Rating |
|-------|--------|-------------------|---------------------------------|------------------|
| ③ | 1290 | 430 | 1.91 | 14 μ F |
| ② | 1090 | 325 | 1.65 | 14 μ F |
| ① | 850 | 240 | 1.18 | 14 μ F |

Maximum permissible power consumption:
All models are suitable for the values shown plus 10% overload.

Pump selection should be within the shaded area for optimum performance.

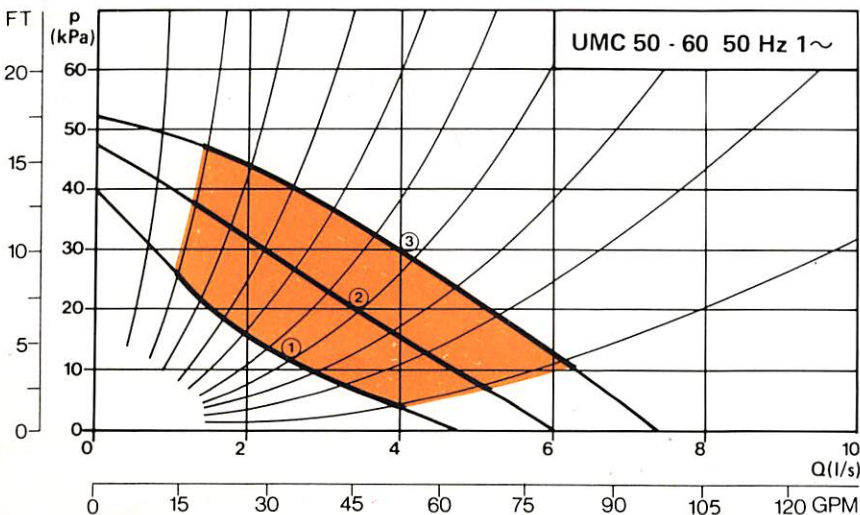

TWIN HEAD MODELS

1 × 240V 50Hz

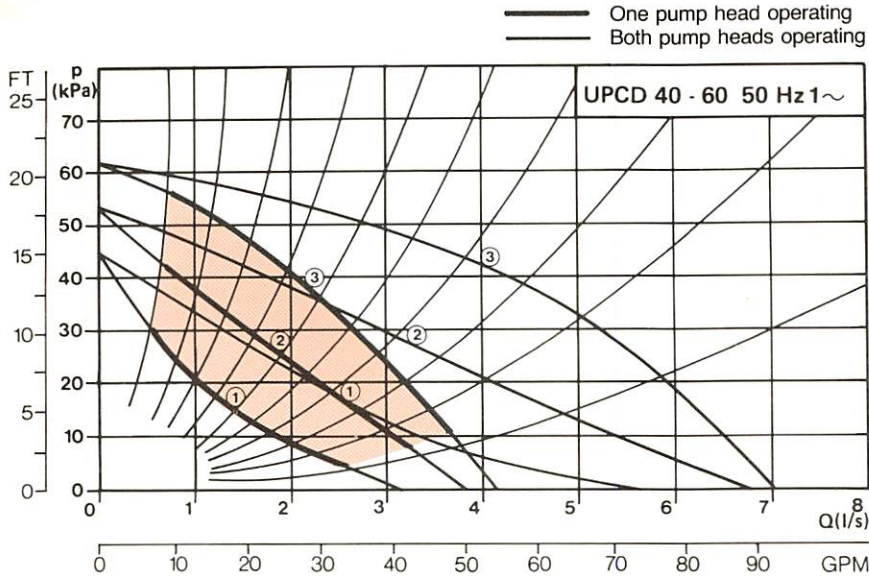

ELECTRICAL DATA

| Speed | R.P.M. | Input Power Watts | Full Load Current Amps 1 x 240V | Capacitor Rating |
|-------|--------|-------------------|---------------------------------|------------------|
| ③ | 2710 | 265 | 1.09 | 6 μ F |
| ② | 2250 | 260 | 1.17 | 6 μ F |
| ① | 1780 | 230 | 1.04 | 6 μ F |

Maximum permissible power consumption:
All models are suitable for the values shown plus 10% overload.

Pump selection should be within the shaded area for optimum performance.

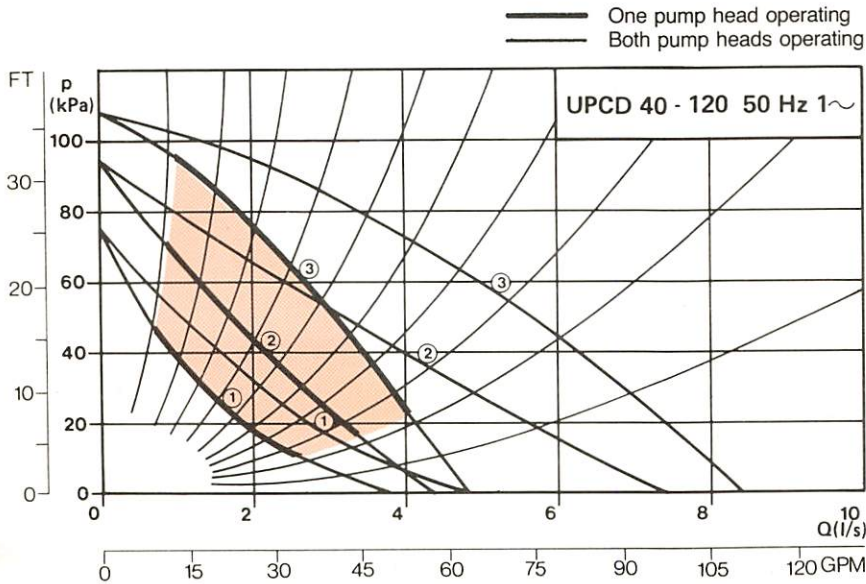

ELECTRICAL DATA

| Speed | R.P.M. | Input Power Watts | Full Load Current Amps 1 x 240V | Capacitor Rating |
|-------|--------|-------------------|---------------------------------|------------------|
| ③ | 2700 | 535 | 2.29 | 10 μ F |
| ② | 2090 | 545 | 2.48 | 10 μ F |
| ① | 1560 | 455 | 2.10 | 10 μ F |

Maximum permissible power consumption:
All models are suitable for the values shown plus 10% overload.

Pump selection should be within the shaded area for optimum performance.

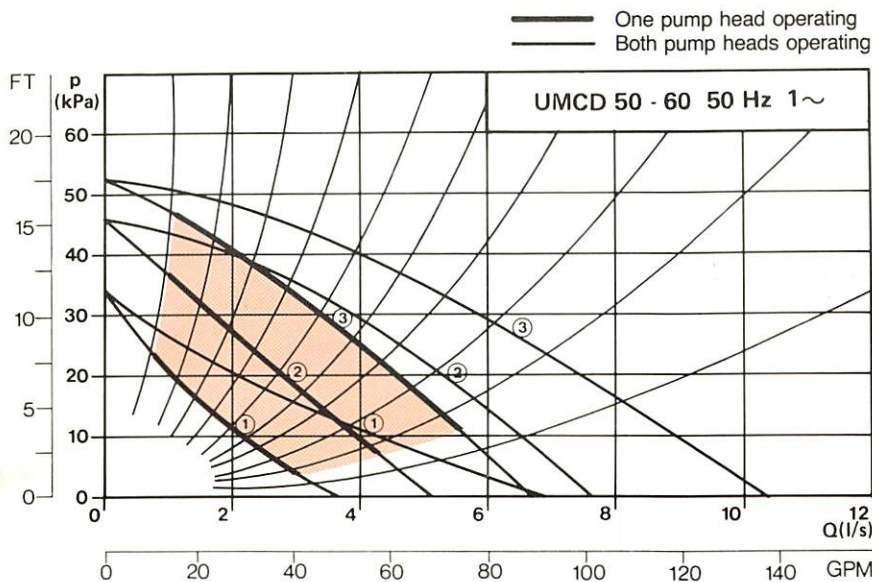

ELECTRICAL DATA

| Speed | R.P.M. | Input Power Watts | Full Load Current Amps 1 x 240V | Capacitor Rating |
|-------|--------|-------------------|---------------------------------|------------------|
| ③ | 1290 | 430 | 1.91 | 14 μ F |
| ② | 1090 | 325 | 1.65 | 14 μ F |
| ① | 850 | 240 | 1.18 | 14 μ F |

Maximum permissible power consumption:
All models are suitable for the values shown plus 10% overload.

Pump selection should be within the shaded area for optimum performance.

SINGLE HEAD MODELS 1 × 240V 50Hz

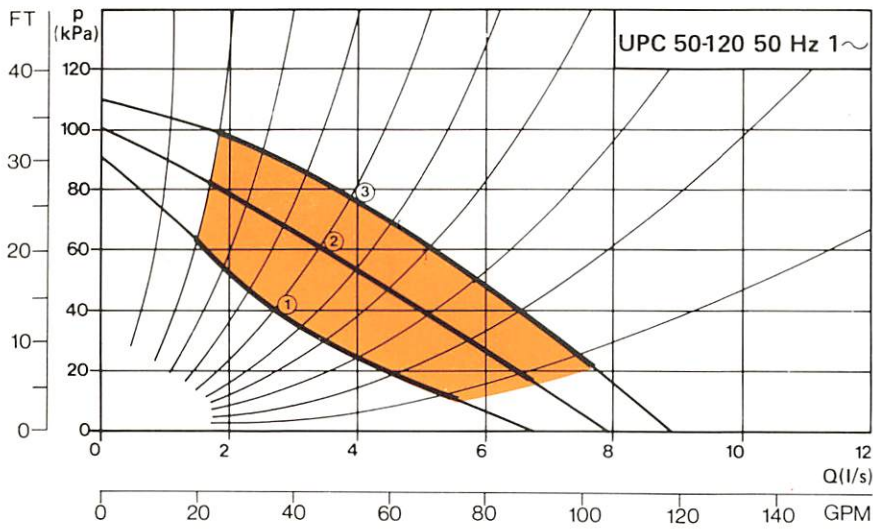

ELECTRICAL DATA

| Speed | R.P.M. | Input Power Watts | Full Load Current Amps 1 x 240V | Capacitor Rating |
|-------|--------|-------------------|---------------------------------|------------------|
| ③ | 2580 | 850 | 3.62 | 20 μ F |
| ② | 2210 | 775 | 3.48 | 20 μ F |
| ① | 1800 | 670 | 3.06 | 20 μ F |

Maximum permissible power consumption:
All models are suitable for the values shown plus 10% overload.

Pump selection should be within the shaded area for optimum performance.

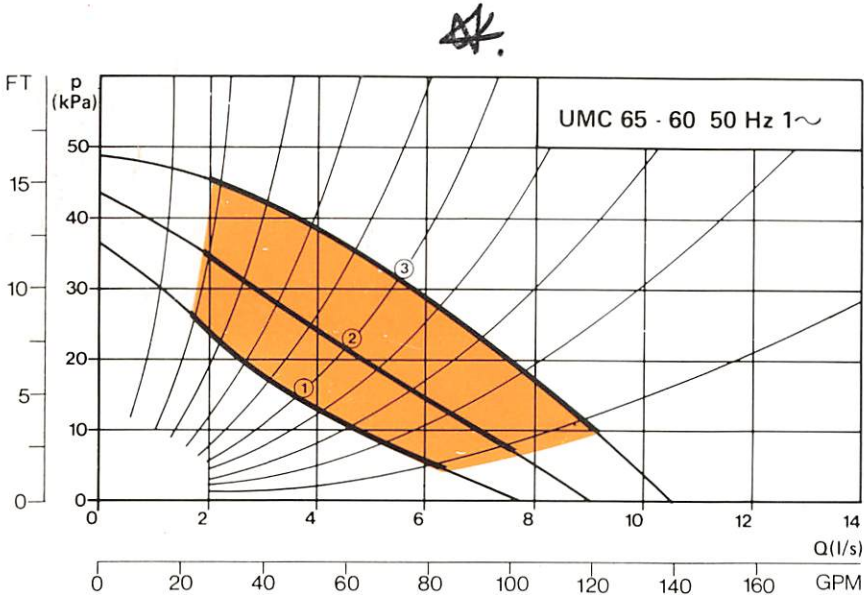

ELECTRICAL DATA

| Speed | R.P.M. | Input Power Watts | Full Load Current Amps 1 x 240V | Capacitor Rating |
|-------|--------|-------------------|---------------------------------|------------------|
| ③ | 1310 | 570 | 2.48 | 20 μ F |
| ② | 1110 | 430 | 2.19 | 20 μ F |
| ① | 920 | 335 | 1.68 | 20 μ F |

Maximum permissible power consumption:
All models are suitable for the values shown plus 10% overload.

Pump selection should be within the shaded area for optimum performance.

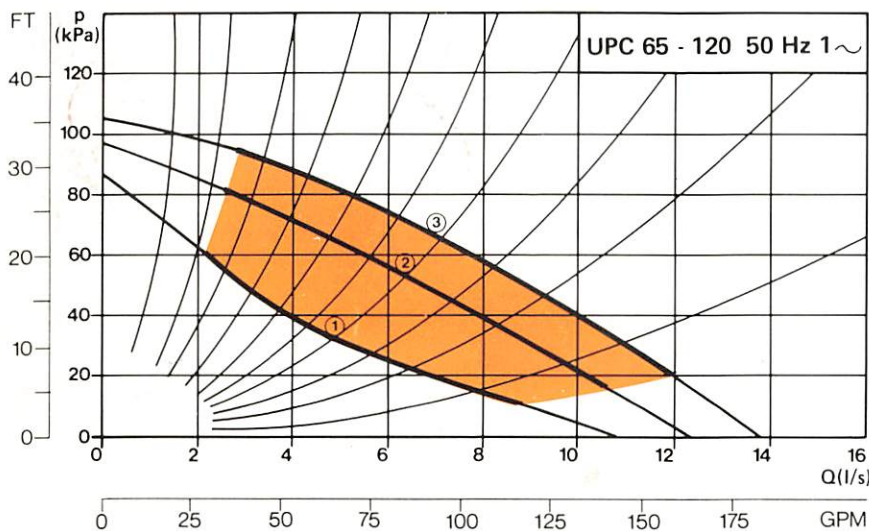

ELECTRICAL DATA

| Speed | R.P.M. | Input Power Watts | Full Load Current Amps 1 x 240V | Capacitor Rating |
|-------|--------|-------------------|---------------------------------|------------------|
| ③ | 2570 | 1190 | 5.14 | 25 μ F |
| ② | 2230 | 1120 | 5.03 | 25 μ F |
| ① | 1820 | 990 | 4.48 | 25 μ F |

Maximum permissible power consumption:
All models are suitable for the values shown plus 10% overload.

Pump selection should be within the shaded area for optimum performance.

TWIN HEAD MODELS

1 × 240V 50Hz

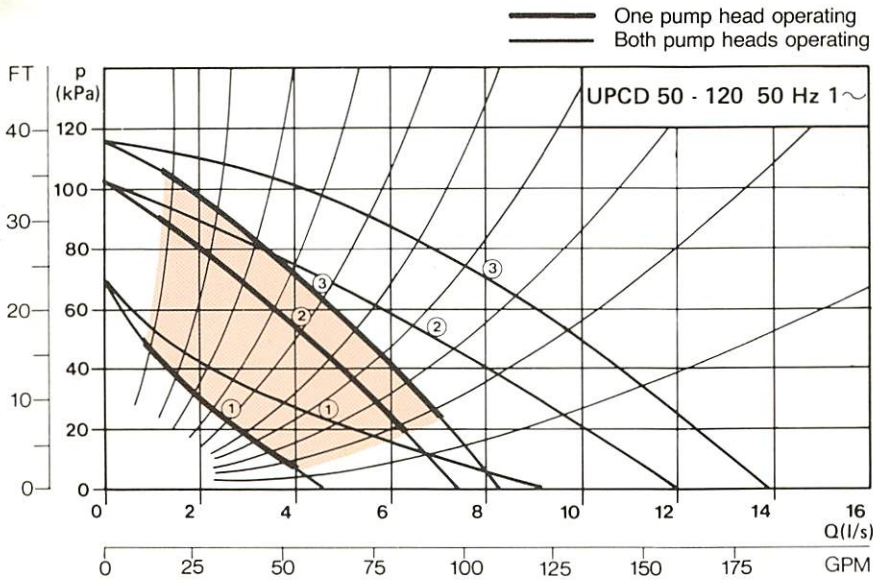

ELECTRICAL DATA

| Speed | R.P.M. | Input Power Watts | Full Load Current Amps 1 x 240V | Capacitor Rating |
|-------|--------|-------------------|---------------------------------|------------------|
| ③ | 2580 | 850 | 3.62 | 20 μ F |
| ② | 2210 | 775 | 3.48 | 20 μ F |
| ① | 1800 | 670 | 3.06 | 20 μ F |

Maximum permissible power consumption:
All models are suitable for the values shown plus 10% overload.

Pump selection should be within the shaded area for optimum performance.

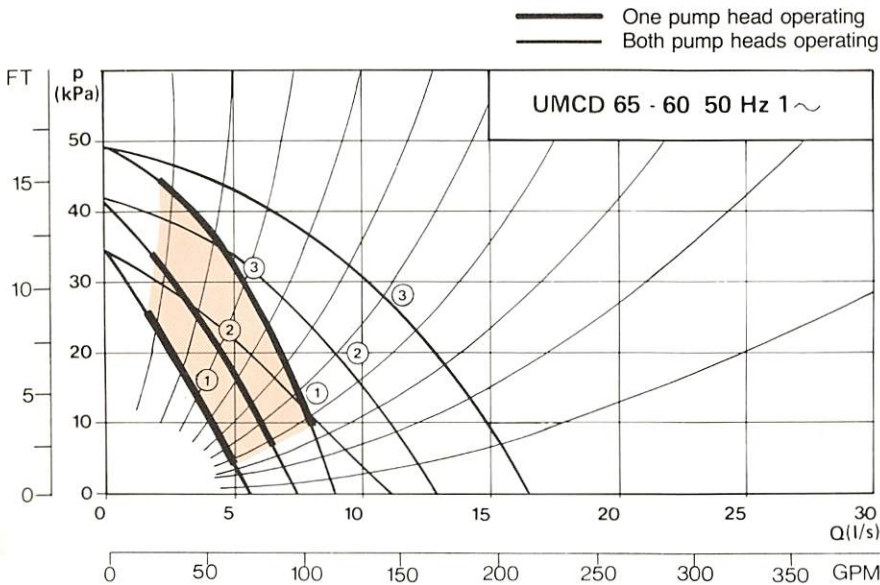

ELECTRICAL DATA

| Speed | R.P.M. | Input Power Watts | Full Load Current Amps 1 x 240V | Capacitor Rating |
|-------|--------|-------------------|---------------------------------|------------------|
| ③ | 1310 | 570 | 2.48 | 20 μ F |
| ② | 1110 | 430 | 2.19 | 20 μ F |
| ① | 920 | 335 | 1.68 | 20 μ F |

Maximum permissible power consumption:
All models are suitable for the values shown plus 10% overload.

Pump selection should be within the shaded area for optimum performance.

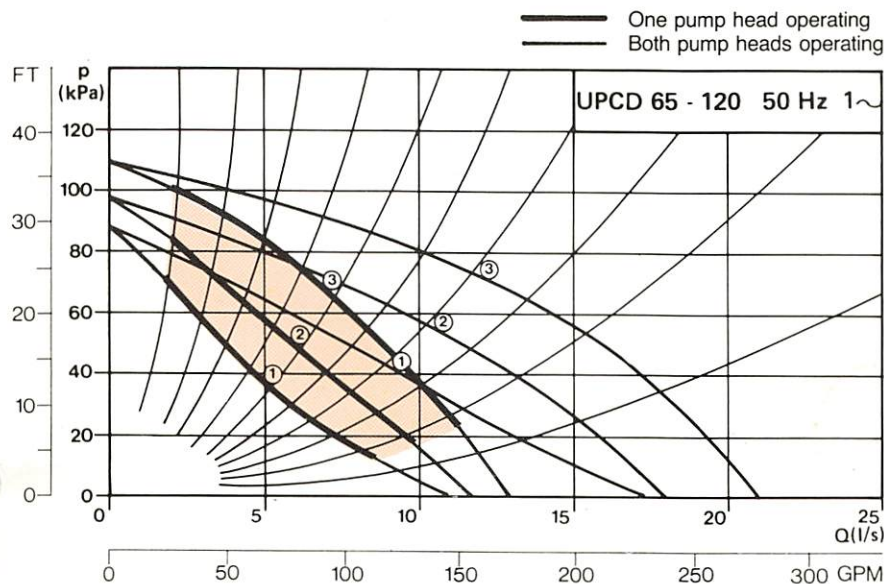

ELECTRICAL DATA

| Speed | R.P.M. | Input Power Watts | Full Load Current Amps 1 x 240V | Capacitor Rating |
|-------|--------|-------------------|---------------------------------|------------------|
| ③ | 2570 | 1190 | 5.14 | 25 μ F |
| ② | 2230 | 1120 | 5.03 | 25 μ F |
| ① | 1820 | 990 | 4.48 | 25 μ F |

Maximum permissible power consumption:
All models are suitable for the values shown plus 10% overload.

Pump selection should be within the shaded area for optimum performance.

SINGLE HEAD MODELS 3 × 415V 50Hz

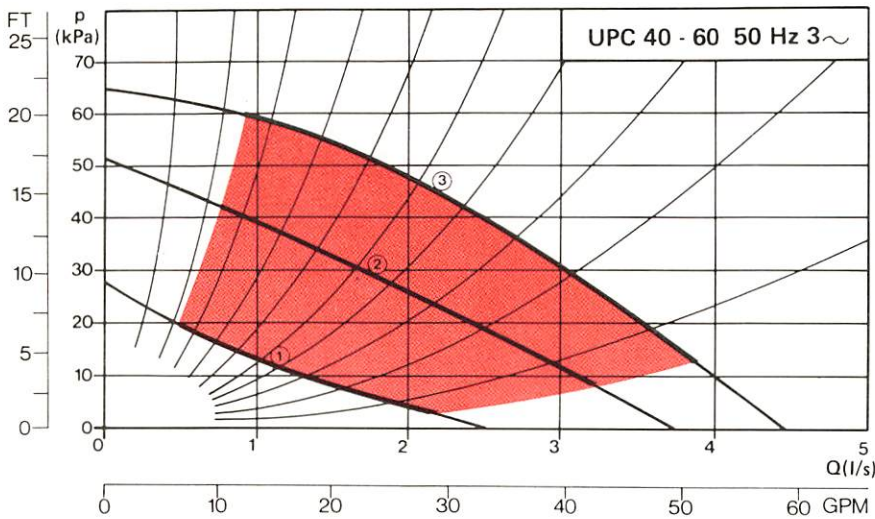

ELECTRICAL DATA

| Speed | R.P.M. | Input Power Watts | Full Load Current Amps 3 x 415V |
|-------|--------|-------------------|---------------------------------|
| ③ | 2790 | 290 | 0.64 |
| ② | 2240 | 185 | 0.31 |
| ① | 1440 | 95 | 0.16 |

Maximum permissible power consumption:
All models are suitable for the values shown plus 10% overload.

Pump selection should be within the shaded area for optimum performance.

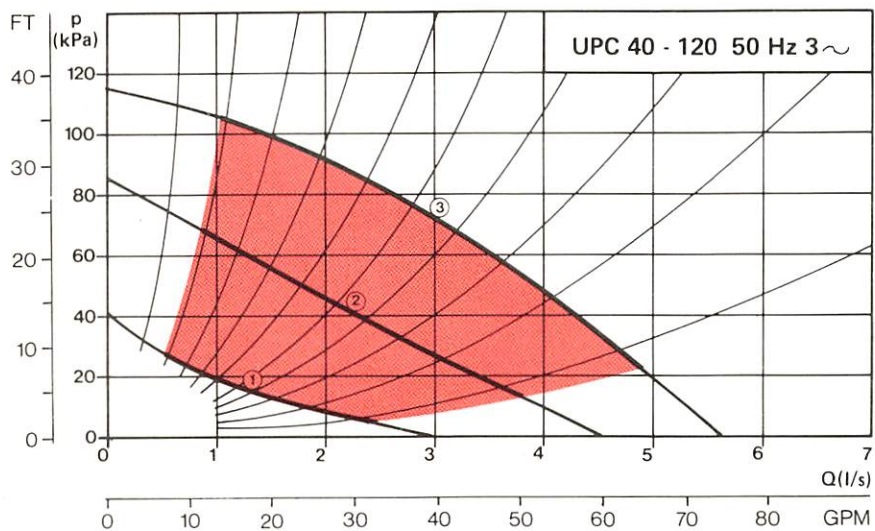

ELECTRICAL DATA

| Speed | R.P.M. | Input Power Watts | Full Load Current Amps 3 x 415V |
|-------|--------|-------------------|---------------------------------|
| ③ | 2730 | 545 | 1.03 |
| ② | 2070 | 330 | 0.56 |
| ① | 1270 | 145 | 0.25 |

Maximum permissible power consumption:
All models are suitable for the values shown plus 10% overload.

Pump selection should be within the shaded area for optimum performance.

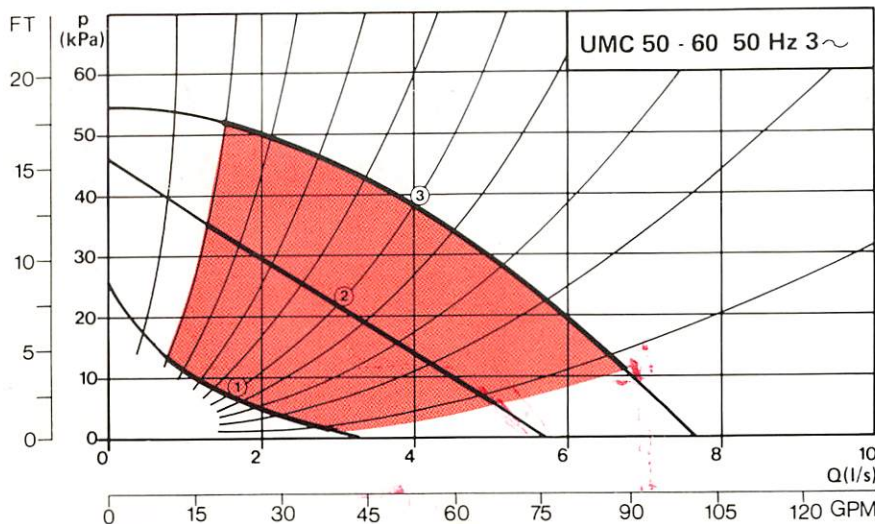

ELECTRICAL DATA

| Speed | R.P.M. | Input Power Watts | Full Load Current Amps 3 x 415V |
|-------|--------|-------------------|---------------------------------|
| ③ | 1380 | 435 | 1.02 |
| ② | 1040 | 255 | 0.44 |
| ① | 580 | 110 | 0.19 |

Maximum permissible power consumption:
All models are suitable for the values shown plus 10% overload.

Pump selection should be within the shaded area for optimum performance.

TWIN HEAD MODELS

3 × 415V 50Hz

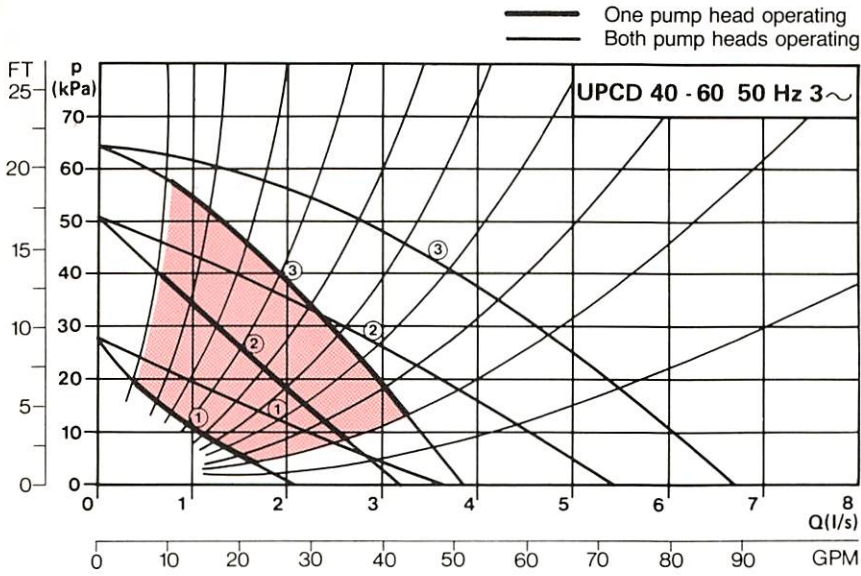

ELECTRICAL DATA

| Speed | R.P.M. | Input Power Watts | Full Load Current Amps 3 x 415V |
|-------|--------|-------------------|---------------------------------|
| ③ | 2790 | 290 | 0.64 |
| ② | 2240 | 185 | 0.31 |
| ① | 1440 | 95 | 0.16 |

Maximum permissible power consumption:
All models are suitable for the values shown plus 10% overload.

Pump selection should be within the shaded area for optimum performance.

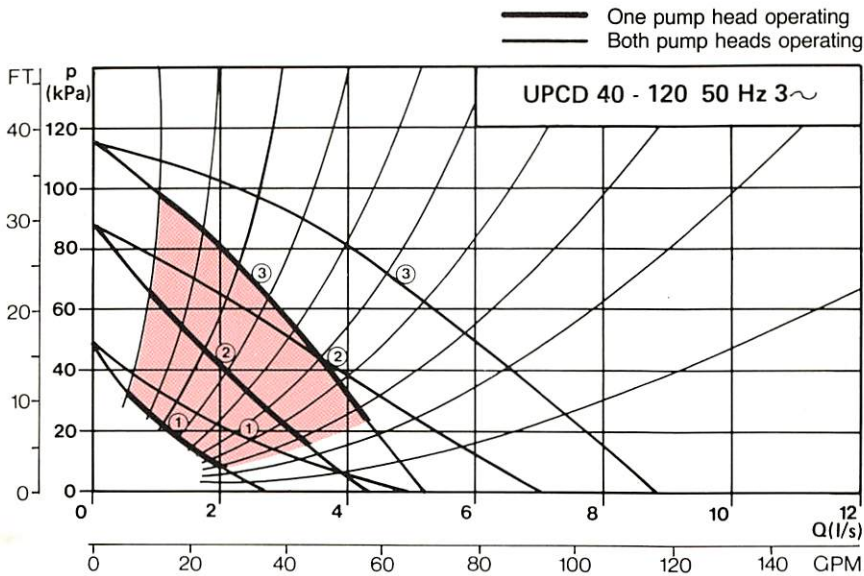

ELECTRICAL DATA

| Speed | R.P.M. | Input Power Watts | Full Load Current Amps 3 x 415V |
|-------|--------|-------------------|---------------------------------|
| ③ | 2730 | 545 | 1.03 |
| ② | 2070 | 330 | 0.56 |
| ① | 1270 | 145 | 0.25 |

Maximum permissible power consumption:
All models are suitable for the values shown plus 10% overload.

Pump selection should be within the shaded area for optimum performance.

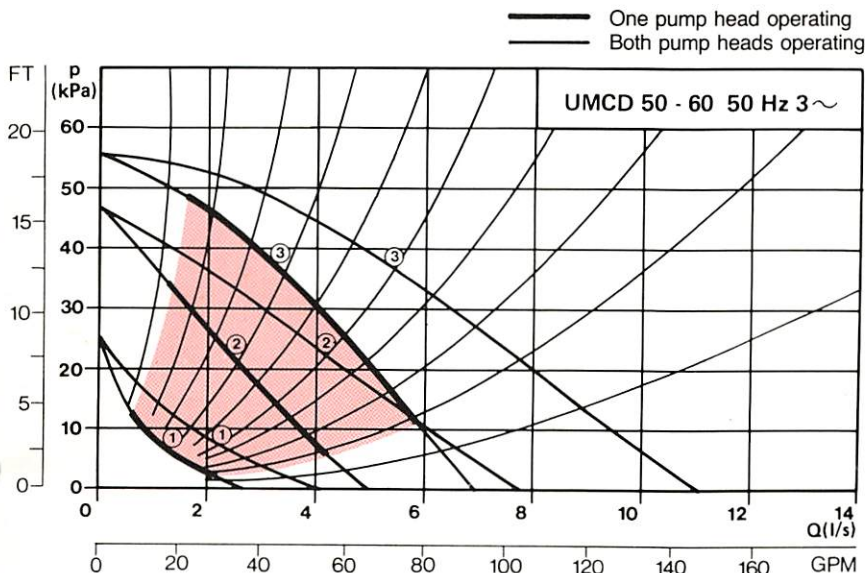

ELECTRICAL DATA

| Speed | R.P.M. | Input Power Watts | Full Load Current Amps 3 x 415V |
|-------|--------|-------------------|---------------------------------|
| ③ | 1380 | 435 | 1.02 |
| ② | 1040 | 255 | 0.44 |
| ① | 580 | 110 | 0.19 |

Maximum permissible power consumption:
All models are suitable for the values shown plus 10% overload.

Pump selection should be within the shaded area for optimum performance.

SINGLE HEAD MODELS 3 × 415V 50Hz

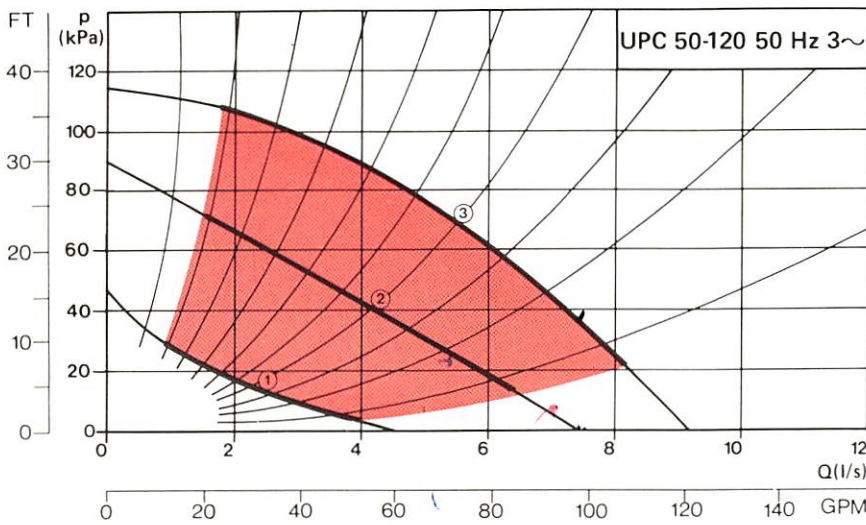

ELECTRICAL DATA

| Speed | R.P.M. | Input Power Watts | Full Load Current Amps 3x 415V |
|-------|--------|-------------------|--------------------------------|
| ③ | 2760 | 940 | 1.69 |
| ② | 2100 | 590 | 0.98 |
| ① | 1250 | 265 | 0.45 |

Maximum permissible power consumption:
All models are suitable for the values shown plus 10% overload.

Pump selection should be within the shaded area for optimum performance.

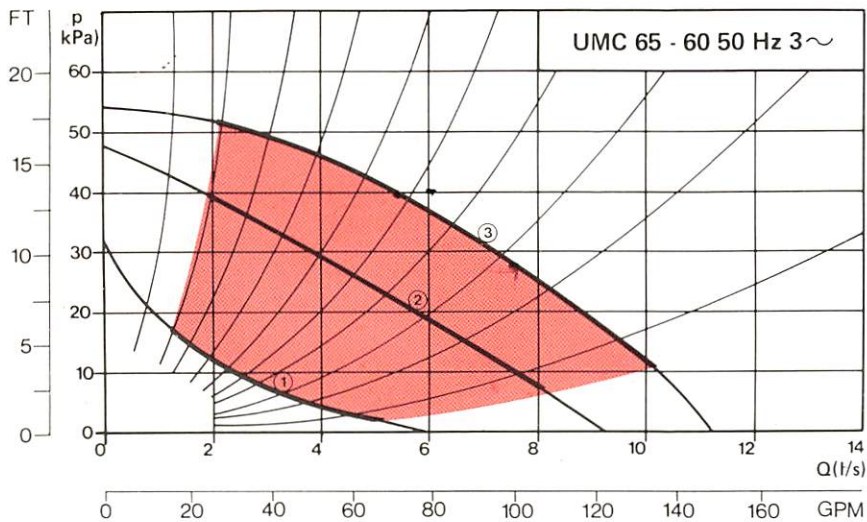

ELECTRICAL DATA

| Speed | R.P.M. | Input Power Watts | Full Load Current Amps 3x 415V |
|-------|--------|-------------------|--------------------------------|
| ③ | 1410 | 570 | 1.47 |
| ② | 1140 | 370 | 0.64 |
| ① | 680 | 170 | 0.31 |

Maximum permissible power consumption:
All models are suitable for the values shown plus 10% overload.

Pump selection should be within the shaded area for optimum performance.

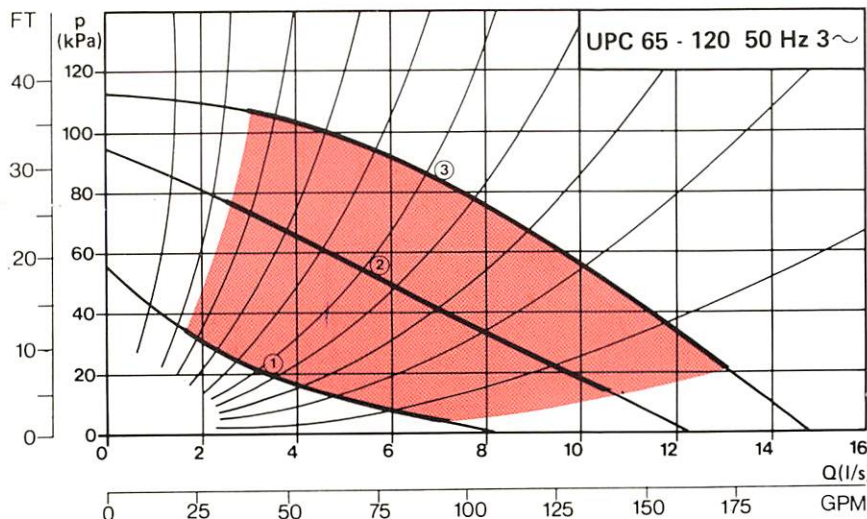

ELECTRICAL DATA

| Speed | R.P.M. | Input Power Watts | Full Load Current Amps 3x 415V |
|-------|--------|-------------------|--------------------------------|
| ③ | 2790 | 1350 | 2.36 |
| ② | 2210 | 915 | 1.48 |
| ① | 1350 | 430 | 0.72 |

Maximum permissible power consumption:
All models are suitable for the values shown plus 10% overload.

Pump selection should be within the shaded area for optimum performance.

TWIN HEAD MODELS

3 × 415V 50Hz

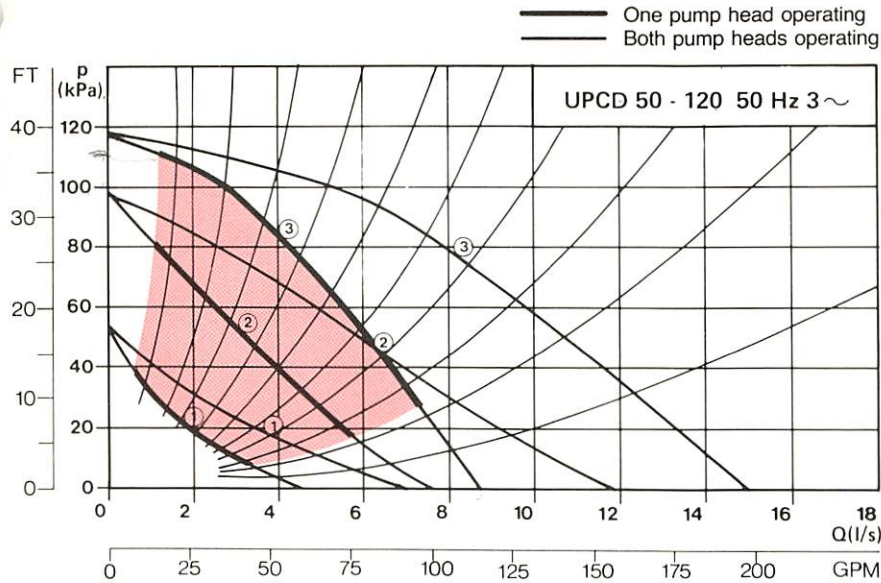

ELECTRICAL DATA

| Speed | R.P.M. | Input Power Watts | Full Load Current Amps 3x 415V |
|-------|--------|-------------------|--------------------------------|
| ③ | 2760 | 940 | 1.69 |
| ② | 2100 | 590 | 0.98 |
| ① | 1250 | 265 | 0.45 |

Maximum permissible power consumption: All models are suitable for the values shown plus 10% overload.

Pump selection should be within the shaded area for optimum performance.

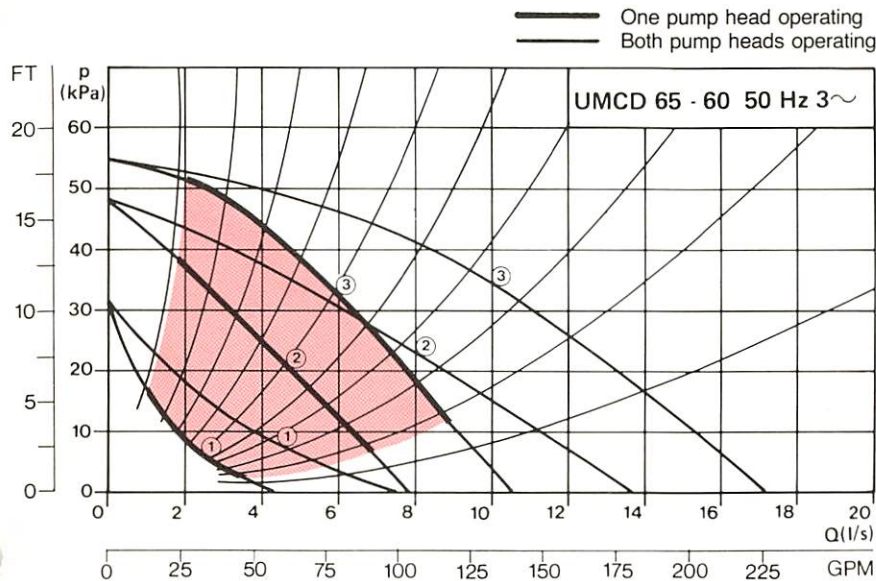

ELECTRICAL DATA

| Speed | R.P.M. | Input Power Watts | Full Load Current Amps 3x 415V |
|-------|--------|-------------------|--------------------------------|
| ③ | 1410 | 570 | 1.47 |
| ② | 1140 | 370 | 0.64 |
| ① | 680 | 170 | 0.31 |

Maximum permissible power consumption: All models are suitable for the values shown plus 10% overload.

Pump selection should be within the shaded area for optimum performance.

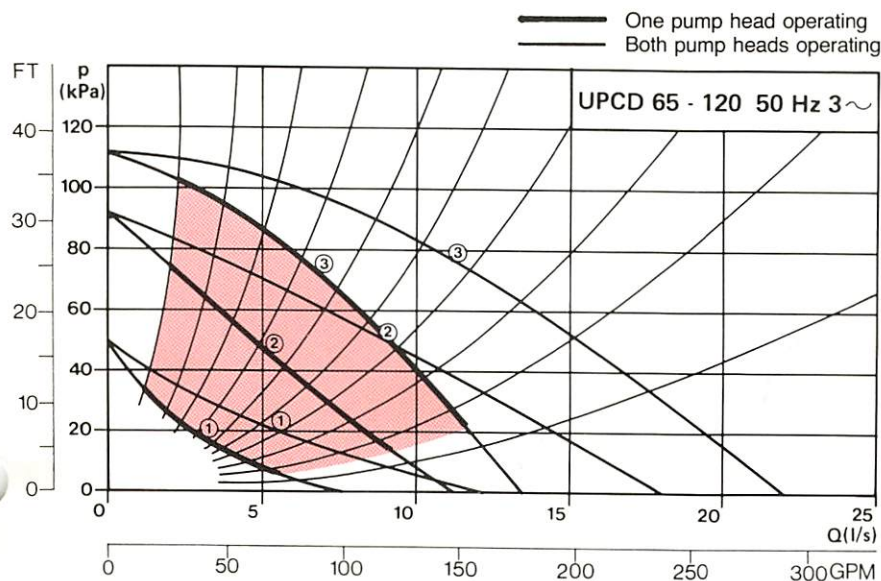

ELECTRICAL DATA

| Speed | R.P.M. | Input Power Watts | Full Load Current Amps 3x 415V |
|-------|--------|-------------------|--------------------------------|
| ③ | 2790 | 1350 | 2.36 |
| ② | 2210 | 915 | 1.48 |
| ① | 1350 | 430 | 0.72 |

Maximum permissible power consumption: All models are suitable for the values shown plus 10% overload.

Pump selection should be within the shaded area for optimum performance.

SINGLE HEAD MODELS 3 × 415V 50Hz

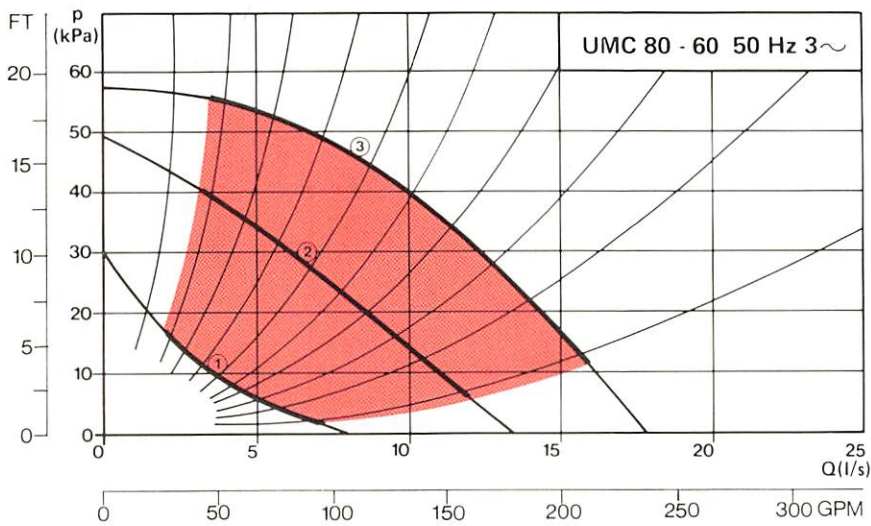

ELECTRICAL DATA

| Speed | R.P.M. | Input Power Watts | Full Load Current Amps 3x415V |
|-------|--------|-------------------|-------------------------------|
| ③ | 1380 | 950 | 2.14 |
| ② | 1050 | 575 | 1.03 |
| ① | 610 | 245 | 0.46 |

Maximum permissible power consumption:
All models are suitable for the values shown plus 10% overload.

Pump selection should be within the shaded area for optimum performance.

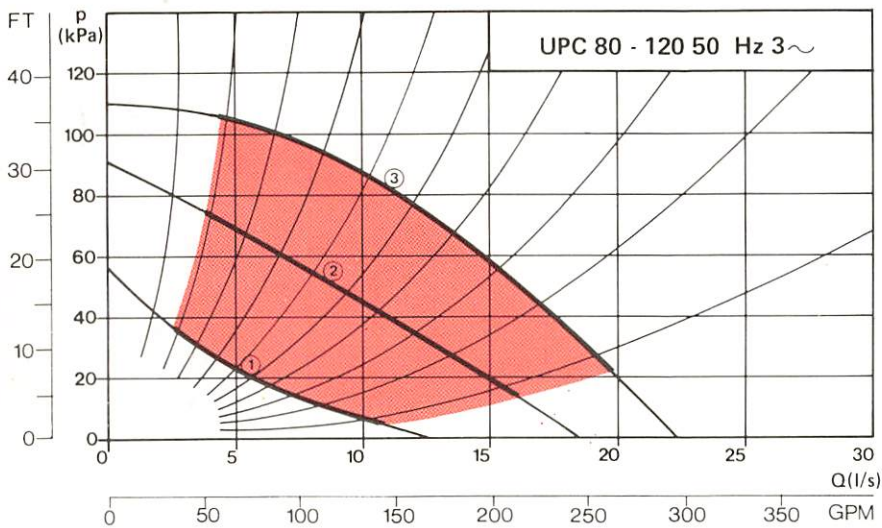

ELECTRICAL DATA

| Speed | R.P.M. | Input Power Watts | Full Load Current Amps 3x415V |
|-------|--------|-------------------|-------------------------------|
| ③ | 2800 | 2020 | 3.51 |
| ② | 2250 | 1385 | 2.22 |
| ① | 1420 | 665 | 1.12 |

Maximum permissible power consumption:
All models are suitable for the values shown plus 10% overload.

Pump selection should be within the shaded area for optimum performance.

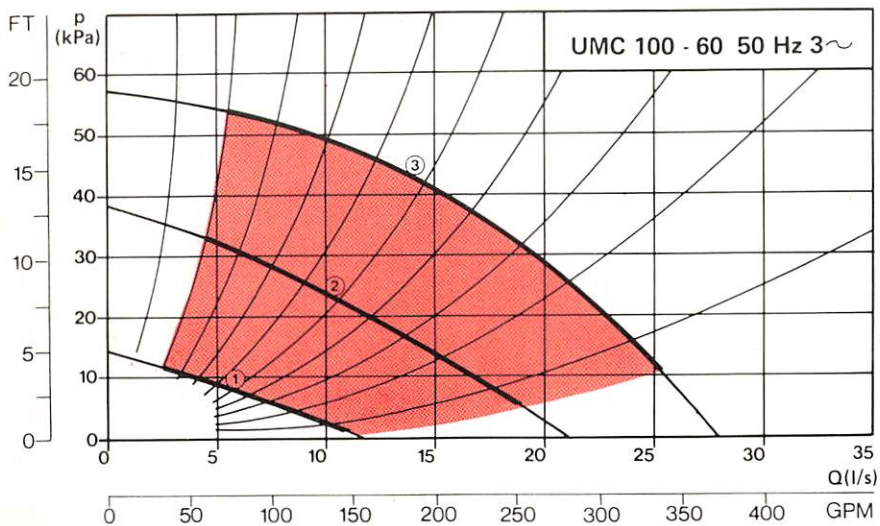

ELECTRICAL DATA

| Speed | R.P.M. | Input Power Watts | Full Load Current Amps 3x415V |
|-------|--------|-------------------|-------------------------------|
| ③ | 1360 | 1370 | 2.90 |
| ② | 980 | 780 | 1.39 |
| ① | 560 | 315 | 0.59 |

Maximum permissible power consumption:
All models are suitable for the values shown plus 10% overload.

Pump selection should be within the shaded area for optimum performance.

01322 293879

DIMENSIONS AND WEIGHTS

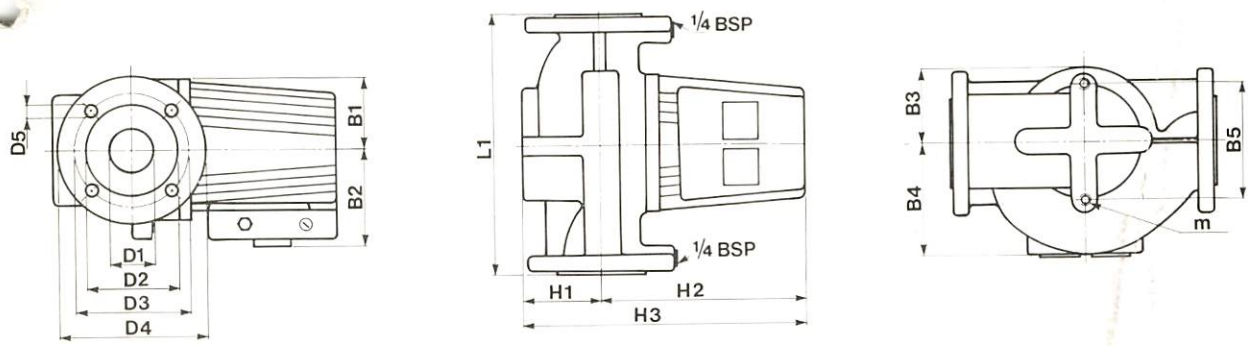

SINGLE HEAD PUMPS UMC/UPC

| Pump Type | Dimension mm | | | | | | | | | | | | | | | Weight | | Volume | |
|------------|--------------|-----|-----|-----|----|--------|-----|-----|-----|-----|-----|-----|-----|-----|-----|--------|--------|----------|----------------|
| | D1 | D2 | D3 | D4 | D5 | No. D5 | H1 | H2 | H3 | L1 | B1 | B2 | B3 | B4 | B5 | m | Net Kg | Gross Kg | m ³ |
| UPC 40-60 | 42 | 80 | 100 | 130 | 14 | 4 | 67 | 236 | 303 | 250 | 73 | 129 | 73 | 90 | 96 | m12 | 14.5 | 17.3 | 0.034 |
| UPC 40-120 | 42 | 80 | 100 | 130 | 14 | 4 | 67 | 236 | 303 | 250 | 73 | 129 | 73 | 90 | 96 | m12 | 15.5 | 18.3 | 0.034 |
| UMC 50-60 | 50 | 90 | 110 | 140 | 14 | 4 | 75 | 210 | 285 | 280 | 91 | 144 | 91 | 104 | 96 | m12 | 22.0 | 24.8 | 0.034 |
| UPC 50-120 | 50 | 90 | 110 | 140 | 14 | 4 | 75 | 210 | 285 | 280 | 91 | 144 | 91 | 104 | 96 | m12 | 22.5 | 25.3 | 0.034 |
| UMC 65-60 | 65 | 110 | 130 | 160 | 14 | 4 | 82 | 262 | 344 | 340 | 98 | 144 | 98 | 124 | 96 | m12 | 29.0 | 32.6 | 0.053 |
| UPC 65-120 | 65 | 110 | 130 | 160 | 14 | 4 | 82 | 262 | 344 | 340 | 98 | 144 | 98 | 124 | 96 | m12 | 30.0 | 33.6 | 0.053 |
| UMC 80-60 | 80 | 128 | 150 | 190 | 18 | 4 | 97 | 264 | 361 | 360 | 102 | 144 | 102 | 130 | 96 | m12 | 35.0 | 38.6 | 0.053 |
| UPC 80-120 | 80 | 128 | 150 | 190 | 18 | 4 | 97 | 264 | 361 | 360 | 102 | 144 | 102 | 130 | 96 | m12 | 36.0 | 39.6 | 0.053 |
| UMC 100-60 | 100 | 148 | 170 | 210 | 18 | 4 | 107 | 304 | 411 | 450 | 123 | 144 | 123 | 167 | 144 | m16 | 44.0 | 49.9 | 0.110 |

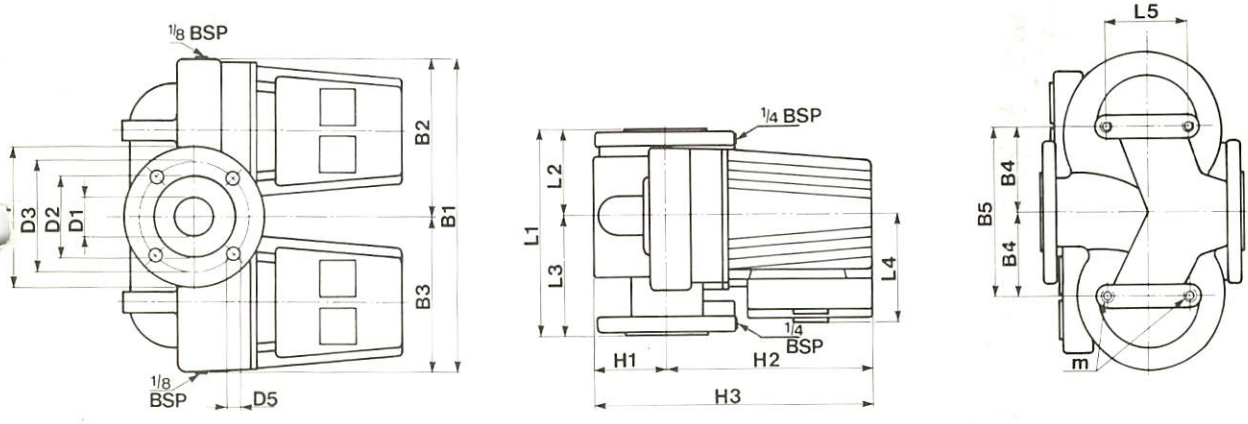

TWIN HEAD PUMPS UMCD/UPCD

| Pump Type | Dimension mm | | | | | | | | | | | | | | | Weight | | Volume | | | | | |
|-------------|--------------|-----|-----|-----|----|--------|-----|-----|-----|-----|-----|-----|-----|-----|-----|--------|-----|--------|-----|-----|--------|----------|----------------|
| | D1 | D2 | D3 | D4 | D5 | No. D5 | H1 | H2 | H3 | L1 | L2 | L3 | L4 | L5 | B1 | B2 | B3 | B4 | B5 | m | Net Kg | Gross Kg | m ³ |
| UPCD 40-60 | 42 | 80 | 100 | 130 | 14 | 4 | 68 | 221 | 289 | 250 | 99 | 151 | 129 | 96 | 364 | 184 | 180 | 100 | 200 | m12 | 27.5 | 31.8 | 0.061 |
| UPCD 40-120 | 42 | 80 | 100 | 130 | 14 | 4 | 68 | 221 | 289 | 250 | 99 | 151 | 129 | 96 | 364 | 184 | 180 | 100 | 200 | m12 | 29.5 | 33.8 | 0.061 |
| UMCD 50-60 | 50 | 90 | 110 | 140 | 14 | 4 | 76 | 210 | 286 | 280 | 120 | 160 | 144 | 120 | 440 | 220 | 220 | 120 | 240 | m12 | 42.0 | 46.3 | 0.061 |
| UPCD 50-120 | 50 | 90 | 110 | 140 | 14 | 4 | 76 | 210 | 286 | 280 | 120 | 160 | 144 | 120 | 440 | 220 | 220 | 120 | 240 | m12 | 43.0 | 47.3 | 0.061 |
| UMCD 65-60 | 65 | 110 | 130 | 160 | 14 | 4 | 84 | 262 | 346 | 340 | 140 | 200 | 144 | 120 | 455 | 231 | 224 | 100 | 200 | m12 | 53.0 | 58.4 | 0.095 |
| UPCD 65-120 | 65 | 110 | 130 | 160 | 14 | 4 | 84 | 262 | 346 | 340 | 140 | 200 | 144 | 120 | 455 | 231 | 224 | 120 | 240 | m12 | 54.0 | 59.4 | 0.095 |
| UMCD 80-60 | 80 | 128 | 150 | 190 | 18 | 4 | 98 | 264 | 362 | 360 | 145 | 215 | 144 | 120 | 464 | 236 | 228 | 120 | 240 | m12 | 59.0 | 64.4 | 0.095 |
| UPCD 80-120 | 80 | 128 | 150 | 190 | 18 | 4 | 98 | 264 | 362 | 360 | 145 | 215 | 144 | 120 | 464 | 236 | 228 | 120 | 240 | m12 | 61.0 | 66.4 | 0.095 |
| UMCD 100-60 | 100 | 148 | 170 | 210 | 18 | 4 | 108 | 304 | 412 | 450 | 189 | 261 | 144 | 144 | 560 | 286 | 274 | 140 | 280 | m16 | 80.0 | 87.7 | 0.172 |

TECHNICAL DATA UMC/UPC

MOTOR DATA

Motor enclosure to IP42 drip proof.

The winding insulation is suitable for a maximum temperature rise of 35°C or 50°C. This information is stamped on the pump nameplate. Each model is fitted with a PG16 compression gland in the terminal box to facilitate cable entry.

Other compression glands are fitted for capacitor wires, and signal modules on single phase, and twin head models as required.

MOTOR PROTECTION

1. The motor has a built-in thermal overload protector which cuts off the mains voltage via a relay incorporated in the motor terminal box. This relay will automatically reset when the temperature in the windings returns to normal.
2. It is not necessary to utilize a contactor type starter with these units, although some method of isolating the supply should be incorporated with a suitable HRC fuse in the supply line.
3. Electrical regulations may require a contactor type starter to be used on some applications and where these are required the starter overloads should be set to trip out at 10% above the motor full load current.
4. The thermal overload will protect the motor on installations where automatic speed changing is incorporated. If a contactor type starter is used it will be impractical to reset the starter overload with each speed change.

SITING THE PUMP

1. To avoid sediment, do not fit the pump in lowest point of system.
2. Fit isolating valves on either side of the pump.
3. To prevent noise, avoid sharp bends either side of the pump.
4. Position the motor away from heat sources and allow access for removing pump head from base.
5. Always try to ensure that the terminal box is not adjacent to hot surfaces, and that the speed change switch is readily accessible for adjustment of pump speed.
6. In non-pressurised systems, position the pump so that it neither pumps over into feed/expansion tank, nor sucks air down the vent pipe. Generally this means fitting the pump in the flow pipe, with the vent on the inlet side of the pump.
7. In pressurised systems, the pump can be fitted in flow or return pipes as required.
8. In systems where all the flow can be stopped while the pump is still running, e.g. systems fitted with thermostatic valves, a by-pass should be fitted between flow and return lines to ensure water flow through the pump at all times (approx. 7.5% of maximum pump capacity).
9. Ensure the pump is not stressed by the pipework and that the pipework is properly supported either side of the pump.

Approximate minimum inlet pressure required to avoid cavitation noise, at all three speed settings.

| | UPC(D)40-60 | UPC(D)40-120 | UMC(D)50-60 | UPC(D)65-120 | UMC(D)80-60 |
|------------------|--------------|--------------|--------------|--------------|-------------|
| | UPC(D)50-120 | UMC(D)65-60 | UPC(D)80-120 | UMC(D)100-60 | |
| Water Temp 75°C | 1.5m | 3.5m | 0.5m | 5.5m | 3.5m |
| Water Temp 90°C | 5.0m | 7.0m | 4.0m | 9.0m | 7.0m |
| Water Temp 120°C | 17.5m | 19.5m | 16.5m | 21.5m | 19.5m |

TWIN HEAD MODELS

For twin head models installed in horizontal pipes it is recommended that an automatic air vent (1/8 inch BSP) is fitted as shown.

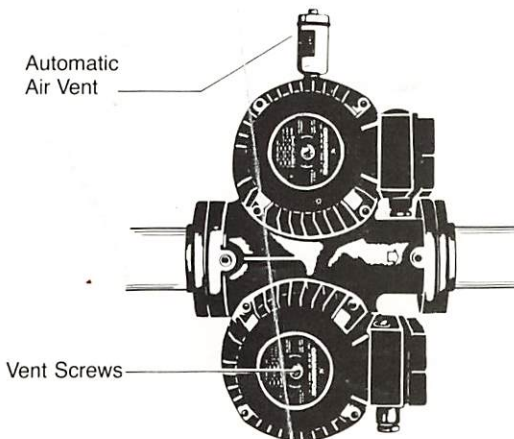

ADVANTAGES OF GRUNDFOS TWIN HEAD PUMPS

Grundfos Twin Head pumps provide a neat, compact and space saving installation where duty and standby operation is required, while only taking up the identical flange to flange space of its single head counterpart (see diagram). A built-in non-return valve in the pump discharge port prevents reverse circulation through the stationary pump and obviates the need for manual valve opening or closing. When the duty pump is switched off and the standby pump is brought into use, the non-return valve will automatically change its position.

This design eliminates unnecessary isolating and non-return valves, yet still enables pump head replacement to be carried out in a matter of minutes without serious interruption to the operation of the heating system. Blanking flanges can be supplied for this purpose at a small extra cost.

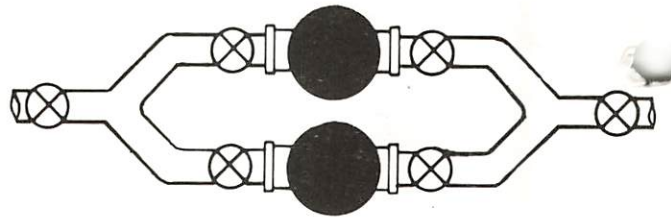
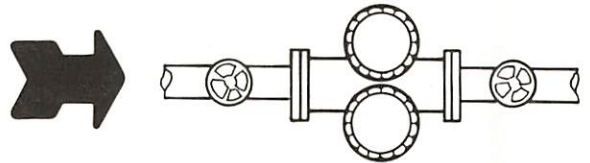

BUILT-IN AUTOMATIC CHANGEOVER

Grundfos twin head models are designed for duty and standby operation and normally the right hand pump head (when pumping vertically upwards) is the duty pump and is fitted with a signal relay. In the event of failure to the duty pump the left hand head will start automatically providing the function selector for both heads is placed in the automatic mode.

INSTALLATION

It is preferable to install Grundfos circulators in a vertical pipe pumping upwards.

This position ensures that the pump shaft is horizontal, which reduces the thrust bearing load and ensures positive air purging from both the rotor chamber and impeller housing.

Pumping downwards in a vertical pipe is not recommended, as this may lead to air locking of the pump, with resultant loss of performance.

Where pumps can only be installed in horizontal pipework, it is imperative that the pump shaft is horizontal, or slightly higher at the vent plug end.

The shaft must not fall below the horizontal plane, even by a few degrees, as this causes premature wear of the top bearing and shaft. Pumps must not be installed with the shaft in a vertical plane, as this may lead to dry running of the top bearing, noise and possible pump failure.

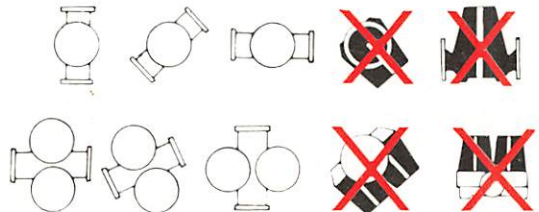

OPERATING

All models are suitable for maximum system pressures of 6 bars (85 psi). UPC40 pumps with 2" flanges have a 4 bar rating. Water temperature range: +15°C to 120°C.

★ To avoid condensation in the motor windings the pumped liquid temperature must always be higher than the ambient temperature. For chilled water applications the UMT/UPT range are recommended.

Maximum Permissible Operating Temperatures

| System Water Temp °C | 120 | 110 | 100 | 90 | 85 |
|----------------------|-----|-----|-----|----|----|
| Air Temp ° | 30 | 40 | 50 | 60 | 65 |

TWIN HEAD MODELS 3 × 415V 50Hz

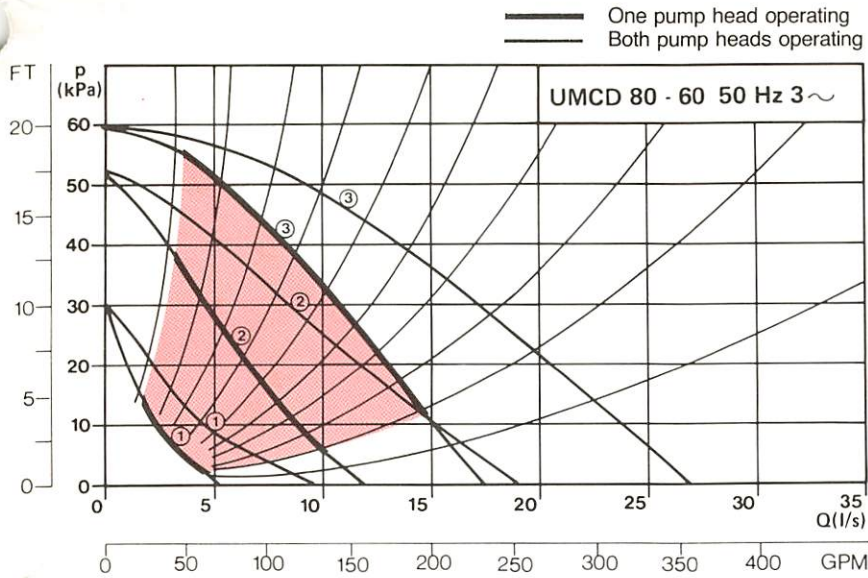

ELECTRICAL DATA

| Speed | R.P.M. | Input Power Watts | Full Load Current Amps 3 x 415V |
|-------|--------|-------------------|---------------------------------|
| ③ | 1380 | 950 | 2.14 |
| ② | 1050 | 575 | 1.03 |
| ① | 610 | 245 | 0.46 |

Maximum permissible power consumption:
All models are suitable for the values shown plus 10% overload.

Pump selection should be within the shaded area for optimum performance.

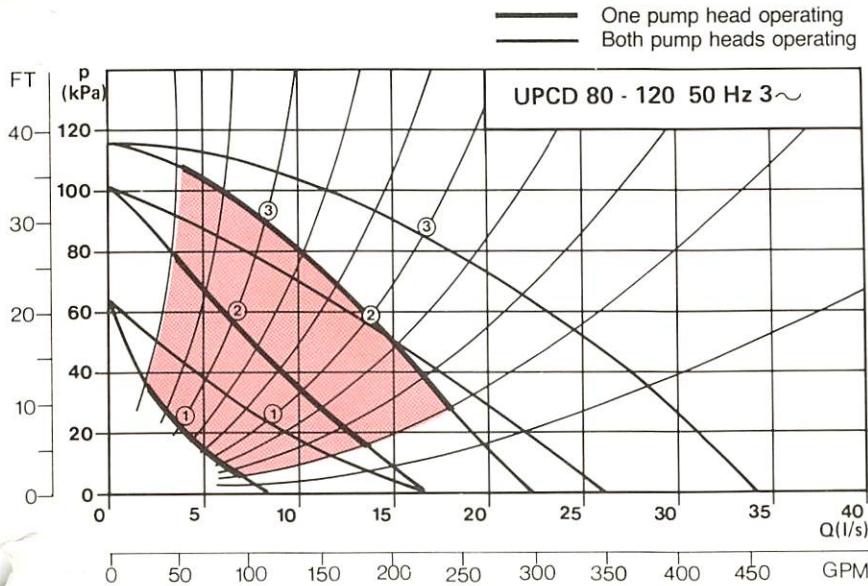

ELECTRICAL DATA

| Speed | R.P.M. | Input Power Watts | Full Load Current Amps 3 x 415V |
|-------|--------|-------------------|---------------------------------|
| ③ | 2800 | 2020 | 3.51 |
| ② | 2250 | 1385 | 2.22 |
| ① | 1420 | 665 | 1.12 |

Maximum permissible power consumption:
All models are suitable for the values shown plus 10% overload.

Pump selection should be within the shaded area for optimum performance.

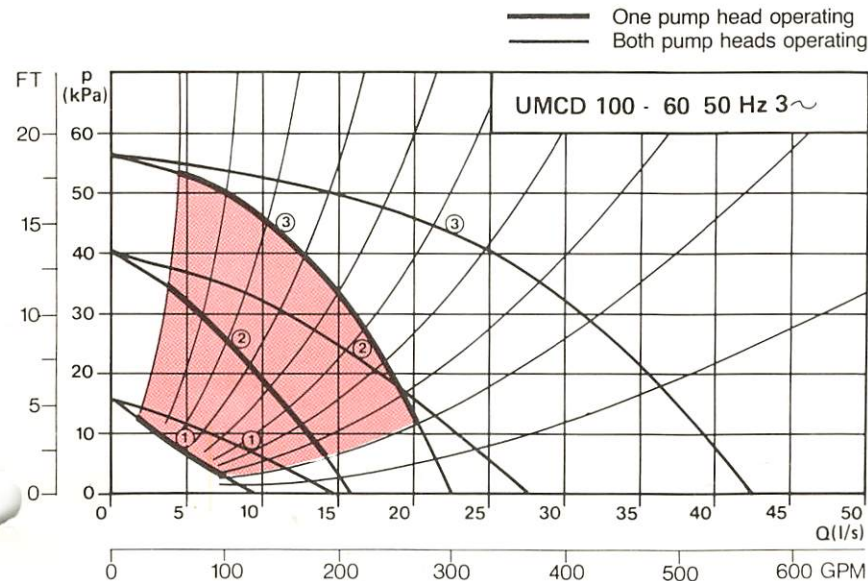

ELECTRICAL DATA

| Speed | R.P.M. | Input Power Watts | Full Load Current Amps 3 x 415V |
|-------|--------|-------------------|---------------------------------|
| ③ | 1360 | 1370 | 2.90 |
| ② | 980 | 780 | 1.39 |
| ① | 560 | 315 | 0.59 |

Maximum permissible power consumption:
All models are suitable for the values shown plus 10% overload.

Pump selection should be within the shaded area for optimum performance.

TECHNICAL DATA

UMC/UPC

MULTI SPEED SELECTION

Each pump head has a built-in speed selector on the motor terminal box. The speed and performance of the pump head is altered by pulling out the speed switch (this disconnects the power to the motor) and turning the switch to the required speed as indicated by the arrow printed on the switch, and then press back into position.

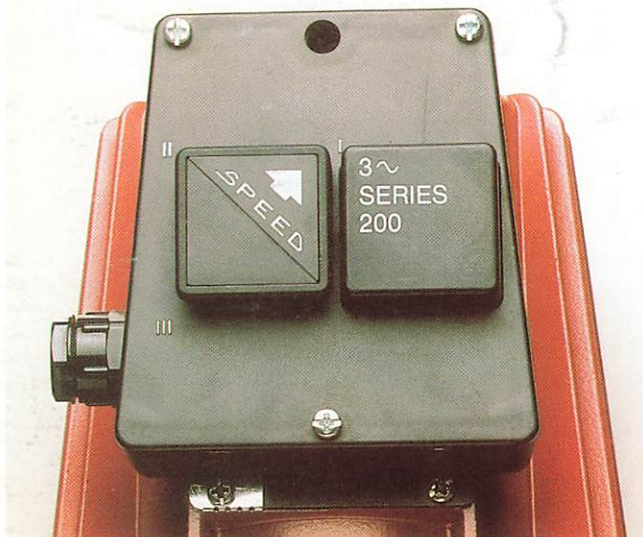

OFF-ON/AUTOMATIC/MANUAL SELECTION SWITCH

The function selector on the terminal box has three positions as follows:

Position 0: In this position the unit is disconnected although if the pump is to be disassembled or adjusted then the electrical supply should be isolated.

Position AUT: The pump is now on the automatic mode and providing the supply has been connected, the unit will run on whichever speed has been selected. The following benefits and options are available in this position.

- i. The pump will automatically restart after a voltage failure or thermal cutout. (If a starter is utilized then the overload relay must be reset first).
- ii. If the thermal cutout cuts the pump off continuously then a small red light will be seen on the motor terminal box indicating an electrical fault.
- iii. A remote stop/start facility can be utilized such as a time clock or simple single pole switch.
- iv. Speed control, and alternate starting can be facilitated by using a suitable pump controller.

Position MAN: The pump is now in the manual mode and providing the supply has been connected, the unit will run on whichever speed has been selected.

If the pump is stopped through voltage failure, speed change, or thermal cutout the pump is restarted by turning the function selector to position AUT and then back to position MAN.

MATERIAL SPECIFICATION

| | |
|----------------|--------------------------------|
| Pump Base | Cast Iron BS1452 Grade 180 |
| Pump Head | Aluminium Alloy |
| Shaft | Stainless Steel |
| Impeller | Stainless Steel BS1449 304 S15 |
| Impeller Nut | Stainless Steel BS1449 304 S15 |
| Neck Ring | Stainless Steel BS1449 304 S15 |
| Rotor Can | Stainless Steel BS1449 304 S15 |
| Rotor Cladding | Stainless Steel BS1449 304 S15 |
| 'O' Rings | EPDM Rubber |
| Shaft Bearings | Tungsten Carbide CG40 |
| Top Bearing | Ceramic |
| Bottom Bearing | Ceramic |
| Thrust Bearing | Carbon |
| Bearing Plate | Stainless Steel BS1449 304 S15 |

SUCTION/DISCHARGE PIPE CONNECTIONS

| MODEL | COUNTER FLANGES |
|------------|---------------------------------------------------------------------------------------------------------------|
| UPC(D) 40 | BS4504 : 1969 table 6/4 N.B. 1½" B.S.P. |
| UPC(D) 40 | BS4504 : 1969 table 6/4 N.B. 1½" B.S.P. opened out to 2" B.S.P. and the flange is suitable for maximum 4 bar. |
| UMC(D) 50 | BS4504 : 1969 table 6/4 N.B. 2" B.S.P. |
| UPC(D) 50 | BS4504 : 1969 table 6/4 N.B. 2" B.S.P. |
| UMC(D) 65 | BS4504 : 1969 table 6/4 N.B. 2½" B.S.P. |
| UPC(D) 65 | BS4504 : 1969 table 6/4 N.B. 2½" B.S.P. |
| UMC(D) 80 | BS4505 : 1969 table 6/4 N.B. 3" B.S.P. |
| UPC(D) 80 | BS4504 : 1969 table 6/4 N.B. 3" B.S.P. |
| UMC(D) 100 | BS4504 : 1969 table 6/4 N.B. 4" B.S.P. |

TYPE DESIGNATION

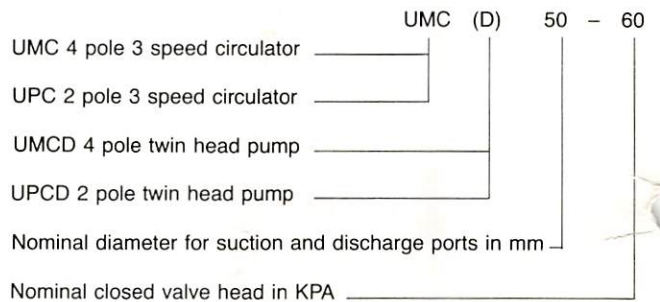

GRUNDFOS PUMPS LTD

Head Office: Grovebury Road, Leighton Buzzard, Beds. LU7 8TL.
Tel (0525) 850000. Telex 825544. Facsimile (0525) 850011.

Northern Area Sales Office: Gawsworth Court, Risley Road, Risley, Warrington, Cheshire WA3 6NJ. Telephone (0925) 813300.
Telex 628162. Facsimile (0925) 830014.

South Eastern Area Sales Office: Unit 13a, Dartford Trade Park, Powder Mill Lane, Dartford, Kent DA1 1NX. Telephone (0322) 92422.
Facsimile (0322) 91025.

It is the continuing policy of Grundfos to develop and improve our products, and we reserve the right to amend prices and specification without prior notice.

UMC/UPC 6/88 EP

GRUNDFOS

