

Automatic Multimeter PM2521

Service Manual

9499 475 01911

820407

S&I
Scientific & Industrial Equipment Division



PHILIPS

Automatic Multimeter PM2521

Service Manual

9499 475 01911

820407



IMPORTANT

This service manual is based on instruments with a serial number DM 01 1145 and onwards.

In chapter 11, modifications to the PM2521, an overview is given of modifications in the earlier instruments.



PHILIPS

IMPORTANT

In correspondence concerning this instrument, please quote the type number and serial number as given on the type plate.

NOTE: *The design of this instrument is subject to continuous development and improvement. Therefore the instrument may not exactly comply with the information in the manual.*

WICHTIG

Bei Schriftwechsel über dieses Gerät wird gebeten, die genaue Typenbezeichnung und die Gerätenummer anzugeben. Diese befinden sich auf dem Leistungsschild.

BEMERKUNG: *Die Konstruktion und Schaltung dieses Geräts wird ständig weiterentwickelt und verbessert. Deswegen kann dieses Gerät von den in dieser Anleitung stehenden Angaben abweichen.*

IMPORTANT

Dans votre correspondance se rapportant à cet appareil, veuillez indiquer le numéro de type et le numéro de série qui sont marqués sur la plaquette de caractéristiques.

REMARQUES: *Cet appareil est l'objet de développements et améliorations continus. En conséquence, certains détails mineurs peuvent différer des informations données dans la présente notice d'emploi et d'entretien.*

CONTENTS

Page

1. CIRCUIT DESCRIPTION	1
1.1. General	1
1.2. Survey of main sections	1
1.2.1. Analog section	1
1.2.2. Control section	6
1.2.3. Display section	6
1.3. Functional description	6
1.3.1. General	6
1.3.2. Analog section (standard measurements)	7
1.3.2.1. Direct voltage measurements	7
1.3.2.2. Alternating voltage measurements	8
1.3.2.3. Direct current measurements	9
1.3.2.4. Alternating current measurements	9
1.3.2.5. Resistance measurements	10
1.3.2.6. Diode measurements	11
1.3.2.7. Temperature measurements	11
1.3.3. Analog section (extended measurements)	12
1.3.3.1. Frequency measurements	12
1.3.3.2. Time measurements	13
1.3.3.3. Trigger measurements	13
1.3.4. Analog section (multifunction circuits)	14
1.3.4.1. R.M.S. convertor	14
1.3.4.2. Impedance convertor	14
1.3.4.3. Active filter	15
1.3.4.4. Analog-to-Digital convertor	15
1.3.5. Control section	17
1.3.5.1. Microprocessor 8035	17
1.3.5.2. Interrupt controller	21
1.3.5.3. Counter	22
1.3.5.4. Analog control	22
1.3.5.5. ROM's and Address/Data decoding	23
1.3.6. Display section	23
1.4. Detailed circuit description	26
1.4.1. Measuring sequence	26
1.4.1.1. Initialisation	27
1.4.1.2. Internal test and adjust routine	28
1.4.1.3. Set up routine	31
1.4.1.4. Measurement routine	31
1.4.1.5. Calculation routine	32
1.4.1.6. Display output routine	32
1.4.2. Analog section (standard measurements)	33
1.4.2.1. Direct voltage measurements	33
1.4.2.2. Alternating voltage measurements	34
1.4.2.3. Direct current measurements	35
1.4.2.4. Alternating current measurements	36
1.4.2.5. Resistance measurements	37
1.4.2.6. Diode measurements	38
1.4.2.7. Temperature measurements	38

1.4.3.	Analog section (extended measurements)	39
1.4.3.1.	Frequency measurements	39
1.4.3.2.	Time measurements	40
1.4.3.3.	Trigger measurements	40
1.4.4.	Analog section (multifunction measurements)	41
1.4.4.1.	R.M.S. convertor	41
1.4.4.2.	Impedance convertor	42
1.4.4.3.	Active filter	43
1.4.4.4.	Analog-to-Digital convertor	44
1.4.5.	Control section	45
1.4.5.1.	Interrupt controller	45
1.4.5.2.	Counter and Input control	47
1.4.5.3.	Analog control	48
1.4.5.4.	ROM circuit and Address/Data decoding	54
1.4.6.	Display section	56
1.4.7.	Power supply	56

2. ACCESS		57
2.1.	Dismantling the PM2521	57
2.1.1.	Removing the top cover	57
2.1.2.	Removing the bottom cover	57
2.1.3.	Removing the front assembly	57
2.2.	Replacing parts	58
2.2.1.	Liquid crystal display, display unit N3, interconnection rubber or function knob ...	58
2.2.2.	Function switch	58
2.2.3.	Thermal fuse	58
3. CHECKING AND ADJUSTING		62
3.1.	DC ranges	63
3.2.	AC ranges	65
3.3.	Trigger level ranges	66
3.4.	Current ranges	68
3.5.	Resistance ranges	68
3.6.	Temperature ranges	69
3.7.	Frequency ranges	69
3.8.	Time ranges	70
4. FAULT-FINDING		71
4.1.	General	71
4.1.1.	Service hints	71
4.1.2.	Fault-finding procedure	71
4.1.3.	Fault-finding with the signature analyser	71
4.2.	Fault-finding flow-charts	72
4.2.1.	Basic check	72
4.2.2.	Function part	73
4.2.3.	V \rightarrow part	74
4.2.4.	V \sim part	74
4.2.5.	Trigger level part	76
4.2.6.	A \rightarrow and A \sim part	78
4.2.7.	Ω part	79
4.2.8.	Analog part	80
4.2.9.	ADC part	81
4.2.10.	Digital part	82
4.2.11.	Free-run	84
4.2.12.	Display part	86
4.2.13.	Power supply check	88

5. PARTS LIST	89
5.1. Top cover assembly	89
5.2. Bottom cover assembly	89
5.3. Front assembly	89
5.4. Switch assembly	89
5.5. Printed circuit board	90
5.5.1. Miscellaneous	90
5.5.2. Resistors	91
5.5.3. Capacitors	94
5.5.4. Semi-conductors	96
5.5.5. Integrated circuits	98
6. CIRCUIT DIAGRAMS AND P.C.B. LAY-OUT	99
7. MODIFICATIONS TO THE PM2521	115
7.1. Modifications to circuit diagrams and p.c.b. lay-outs	115
7.2. Modifications to components	120
7.3. Modifications to the adjusting procedure	120
8. COMPONENT DATA	121
8.1. Semi-conductors	121
8.2. LOCMOS circuits (HEF)	122
8.3. OQ circuits	127
8.4. Display interface circuits	133
8.5. Operational amplifiers	137
8.6. Low power Schottky circuits (LS)	139
8.7. Memory and microprocessor	143
8.8. Resistors	146

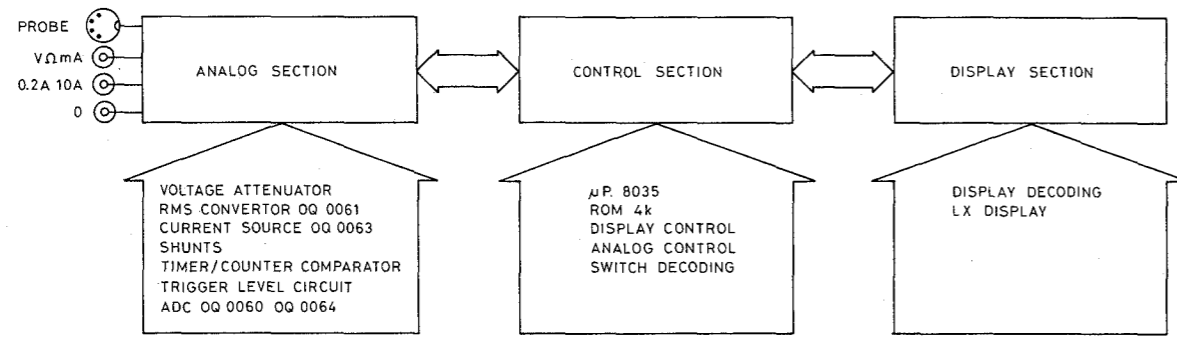
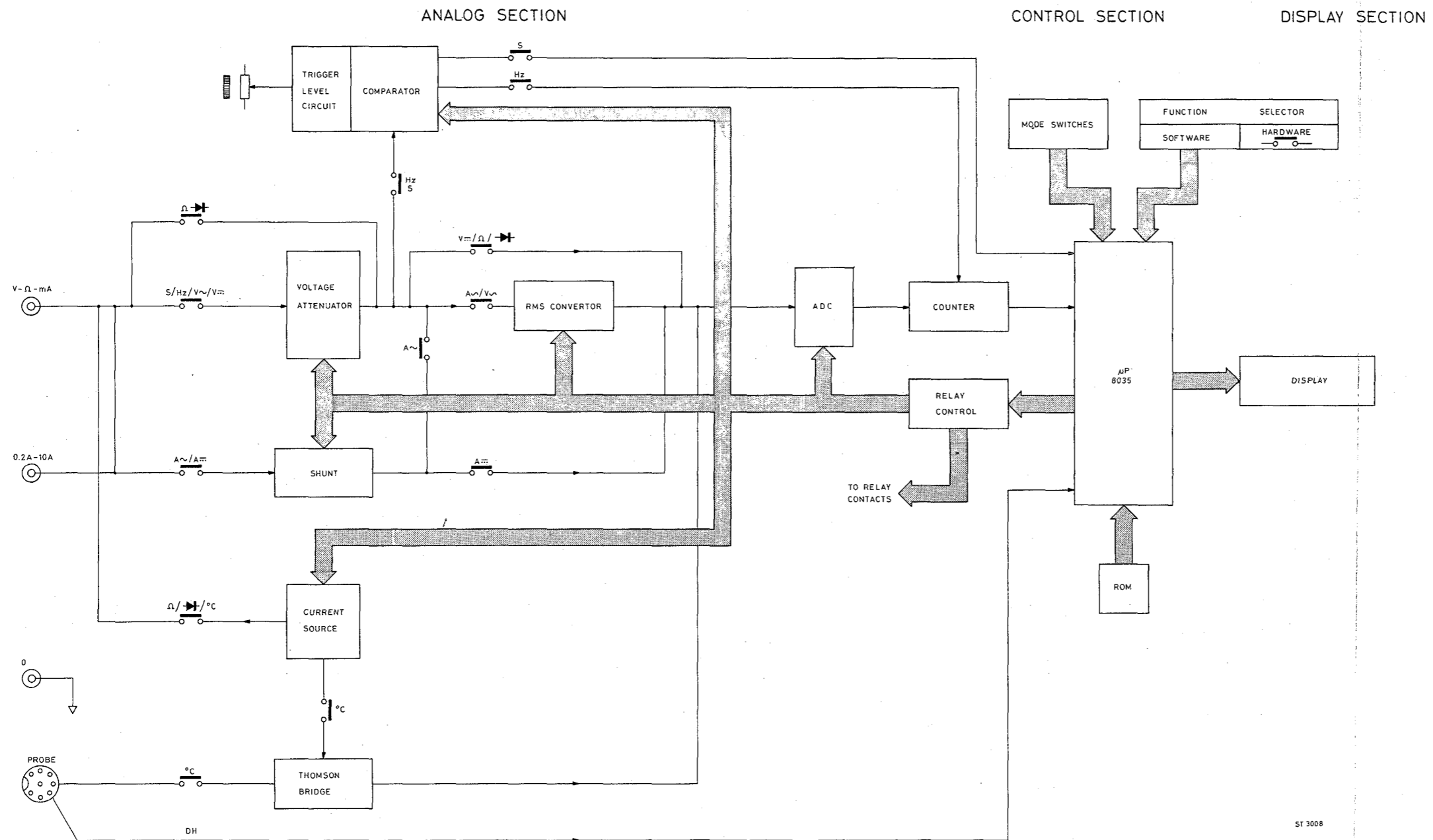

Fig. 1. Basic built-up of PM2521

513007



513008

Fig. 2. Blockdiagram PM2521

Fig. 1. Basic built-up of PM2521

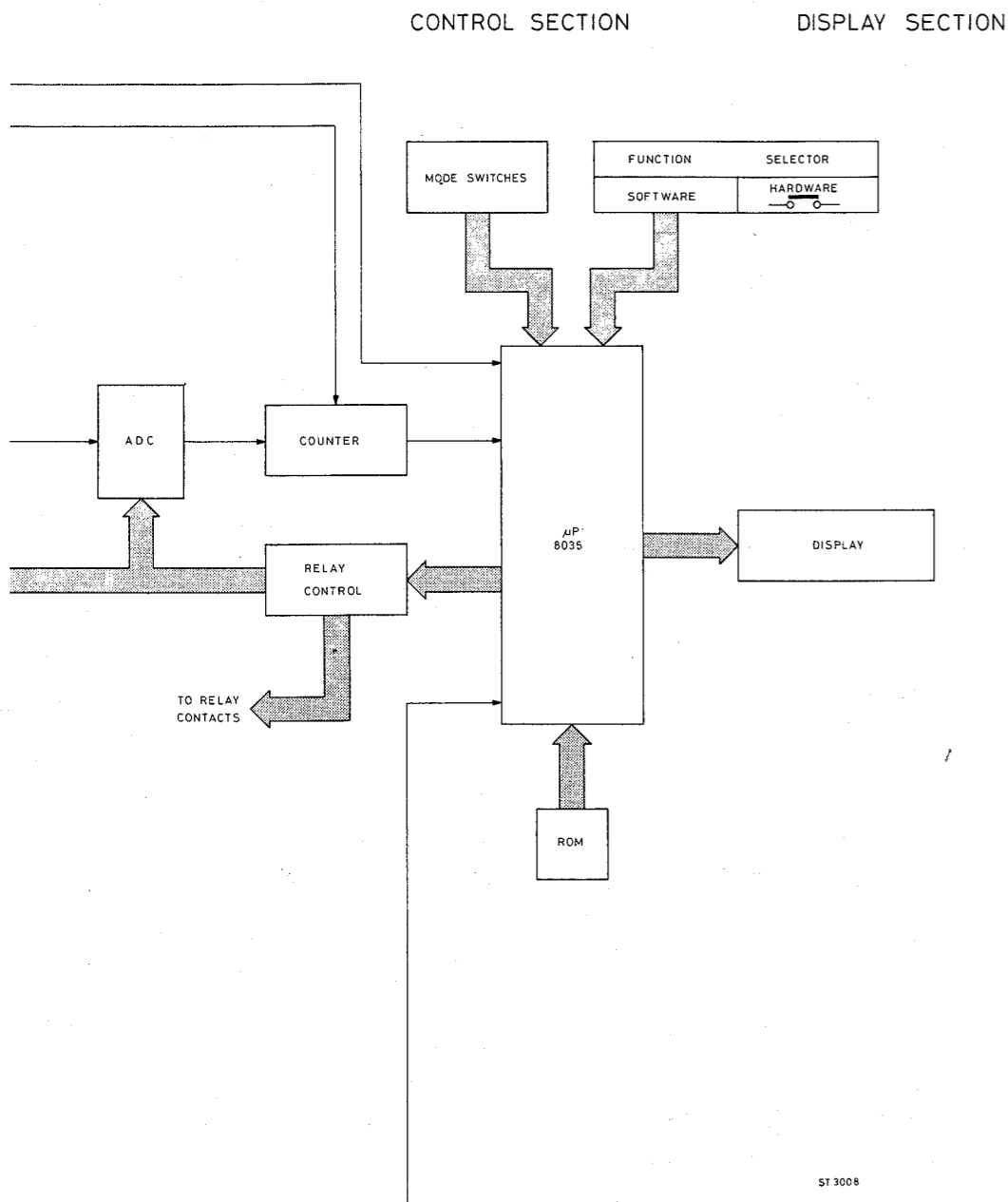

Fig. 2. Blockdiagram PM2521

1.2.2. Control Section

The control section comprises the following circuit elements:

- The interrupt controller
The inputs for the interrupt controller are the mode switches and the trigger level circuit output (timer part)
- The counter with its input control
The inputs for the counter circuit are:
 - The ADC output
 - The trigger level circuit output (counter part)
 The input control is directed from the microcomputer
- The ROM with address/data decoding
- The microcomputer 8035
- The function selector with decoding
- The mode switches
- The relay/FET switch control

1.2.3. Display section

The display section consists of:

- The display interface circuit
- The 5-digit liquid-crystal display

1.3. FUNCTIONAL DESCRIPTION

1.3.1. General

In common with most microcomputer-based measuring instruments, the Automatic Multimeter PM2521 is designed around the microcomputer integrated circuit - an 8035 with a 4K external ROM. The 8035 comprises a microprocessor with an internal 64-byte RAM, one true 8-bit bidirectional port and two quasi-bidirectional ports.

In conjunction with the 4K ROM, the μP controls the timing and measuring functions of the instrument. It also provides the reading of the display.

In the analog section, all the inputs are converted into d.c. signals, attenuated as necessary under μP control and supplied to the ADC.

The ADC converts these d.c. analog representations of the input signals into digital logic signals suitable for the μP .

The measuring sequence from analog section to control and display sections is briefly outlined in the flow-chart, Fig. 3.

LIST OF FIGURES

Fig. 1.	Basic build-up of PM2521	4
Fig. 2.	Block diagram PM2521	4
Fig. 3.	Measurement flow-chart	7
Fig. 4.	DC attenuator	8
Fig. 5.	AC attenuator	8
Fig. 6.	Basic I-V convertor	9
Fig. 7.	Ω measurements	10
Fig. 8.	Thomson bridge	11
Fig. 9.	Block diagram - frequency measurements	12
Fig. 10.	Normal trigger mode	13
Fig. 11.	Special trigger mode	13
Fig. 12.	Basic V-I convertor	14
Fig. 13.	Low-pass active filter	15
Fig. 14.	Switching part ADC	15
Fig. 15.	Basic functional blocks of 8035 μ P	17
Fig. 16.	Pin allocation and functions of 8035 μ P	19
Fig. 17.	Mode switch interrupts	21
Fig. 18.	Block diagram of the control section	24
Fig. 19.	Measuring sequence	26
Fig. 20.	Calibration routine	29
Fig. 21.	Flow-chart internal test and adjust routine	28
Fig. 22.	Flow-chart display output routine	32
Fig. 23.	DC attenuator details	33
Fig. 24.	AC attenuator details	34
Fig. 25.	I-V convertor	35
Fig. 26.	Ω measurements details	37
Fig. 27.	Temperature bridge	38
Fig. 28.	Frequency measurements	39
Fig. 29.	R.M.S. convertor	41
Fig. 30.	Impedance convertor	42
Fig. 31.	Active filter	43
Fig. 32.	V-I convertor	44
Fig. 33.	Interrupt controller	45
Fig. 34.	Counter input control	47
Fig. 35.	Counter	48
Fig. 36.	Switch decoding	49
Fig. 37.	Relay/FET control	51
Fig. 38.	Address decoding	54
Fig. 39.	Memory	55
Fig. 40.	Display interface	56
Fig. 41.	Removing the top cover	60
Fig. 42.	Removing the bottom cover and front	60
Fig. 43.	Removing the front	60
Fig. 44.	Front assembly	60
Fig. 45.	Removing the thermal fuse	60
Fig. 45a.	Removing the thermal fuse	60
Fig. 46.	Adjusting elements	61
Fig. 47.	Waveforms V \sim part	74
Fig. 48.	Waveforms trigger-level part	77
Fig. 49.	Waveform, analog part	80
Fig. 50.	Waveform, ADC part	81

Fig. 51.	Waveforms, digital part	82
Fig. 52.	Waveforms, free-run	85
Fig. 53.	Switch for high current ranges	90
Fig. 54.	Switch p.c.b. lay-out, front view	99
Fig. 55.	Switch p.c.b. lay-out, rear view	99
Fig. 56.	Display p.c.b. lay-out, component side	100
Fig. 57.	Display p.c.b. lay-out, conductor side	100
Fig. 58.	Adapting the mains transformer	101
Fig. 59.	Main p.c.b. lay-out, component side	102
Fig. 60.	Main p.c.b. lay-out, conductor side	103
Fig. 61.	Additional components on conductor side of main p.c.b.	104
Fig. 62.	Power supply circuit diagram	105
Fig. 63.	Analog section circuit diagram	110
Fig. 64.	Digital section circuit diagram	111
Fig. 65.	Modifications in active filter	115
Fig. 66.	Modifications in current source	116
Fig. 67.	Main p.c.b. lay-out, component side former version	117
Fig. 68.	Main p.c.b. lay-out, conductor side former version	118
Fig. 69.	Additional components on conductor side of main p.c.b.	119

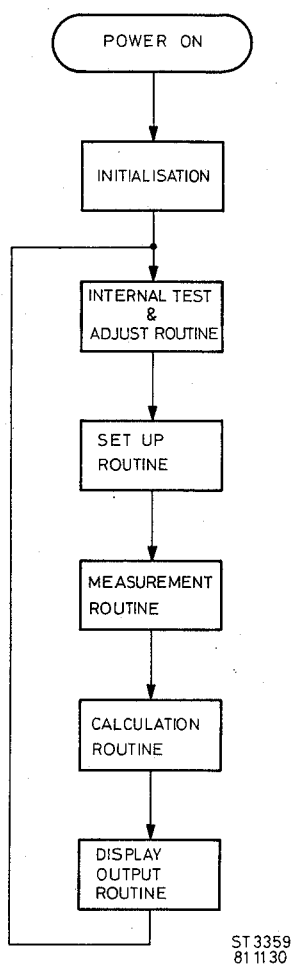

Fig. 3. Measurement flow-chart

The various circuit functions are now described together with explanations of basic principles as necessary.

1.3.2. Analog section (standard measurements)

1.3.2.1. Direct voltage measurements

The unknown voltage to be measured is passed to the a.c./d.c. voltage attenuator where by means of resistors switched by relay contacts controlled from the μP , the attenuation factor is changed from the basic 2V range to give 20V, 200V and 2000V ranges. The 200mV range uses the 2V range attenuator position, but the ADC is switched to the 100mV position to give the necessary $\times 10$ gain factor.

From the voltage attenuator the signal is fed to an active filter, which stabilises the voltage passed to the ADC. The ADC converts this analog voltage into digital form for the μP to measure.

1.3.2.5. Resistance measurements

The unknown resistance is connected between the V-Ω-mA and 0 input terminals and supplied internally with a constant-current source dependent on the range selected. This current results in a potential difference across the resistor which (by Ohm's Law) is proportional to the resistance value. The resulting voltage signal is applied as for V measurements to the voltage attenuator, the active filter and the ADC.

The circuit functions as shown in Fig. 7.

A known constant current supplied by the programmable current source A401 (OQ0063) flows through the unknown resistor Rx.

There are three basic ranges:

Ω			200
kΩ	2	20	200
MΩ	2	20	

Depending on the range selected (manual or automatic selection), the currents are determined by the signals RNGC, RNGD and RNGE:

I _{rx}	RNGC	RNGD	RNGE	RANGE	V _x	INDICATION
1mA	-10V	-10V	0V	200 Ω	-0,2V	200.00 Ω
1mA	-10V	-10V	0V	2kΩ	- 2V	2.0000kΩ
100μ A	-10V	-10V	-10V	20kΩ	- 2V	20.000kΩ
10μ A	0V	-10V	-10V	200kΩ	- 2V	200.00kΩ
1μ A	-10V	0V	-10V	2MΩ	- 2V	2.0000MΩ
100n A	0V	0V	-10V	20MΩ	- 2V	20.000MΩ

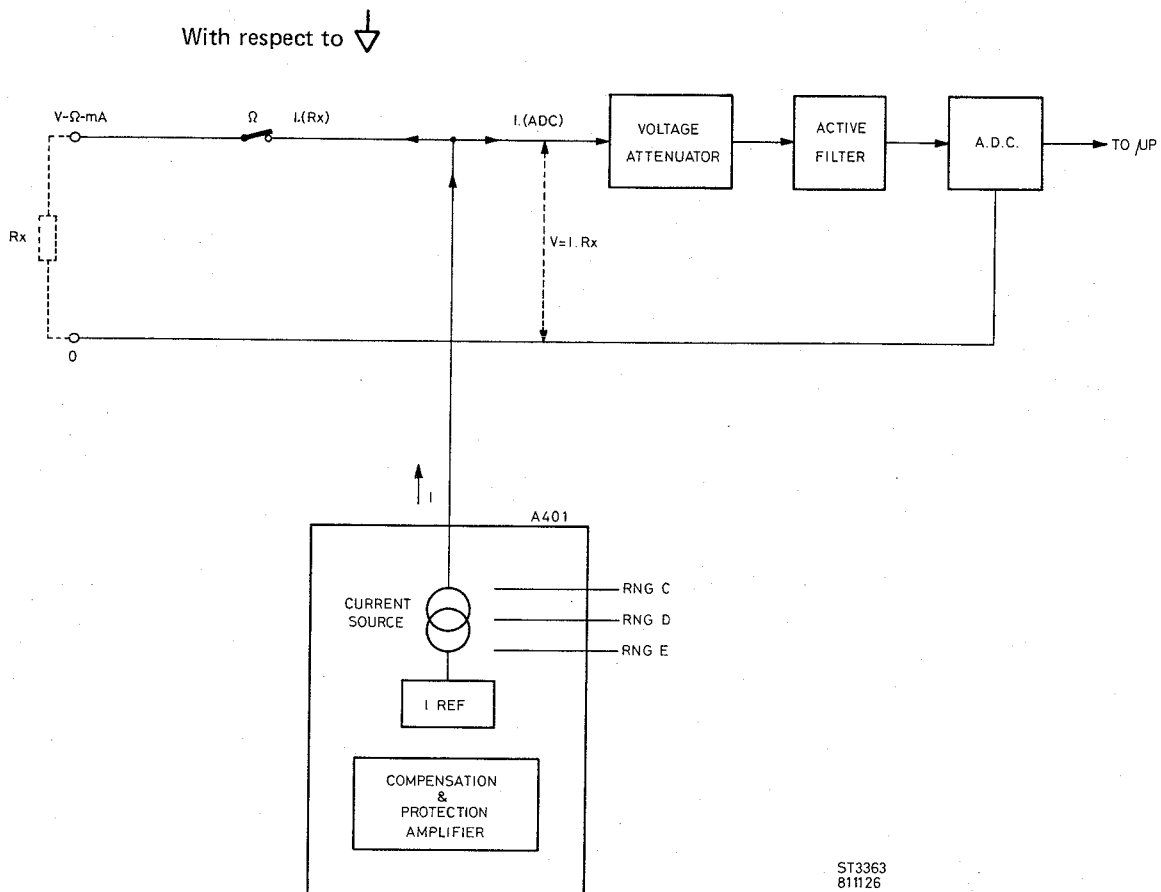

ST3363
81126

Fig. 7. Ω measurements

In practice, the internal resistance of the ADC (10MΩ) also draws a small amount of current, but this is compensated by an equivalent current through the compensation amplifier circuit.

1.3.2.6. Diode measurements

The measurement of diodes and semiconductor junctions is performed in the same way as for resistance measurements in the $2k\Omega$ range.

The value displayed is the equivalent of the voltage measured in the forward or reverse direction across the diode junction in the 2V range; i.e. the constant current multiplied by the diode resistance.

For diode measurements the constant current derived from the OQ0063 is 1mA (see previous section).

1.3.2.7. Temperature measurements

For temperature measurements, a constant current from the A401 current source flows through the resistance element of the temperature probe to produce a voltage drop across it. This resistance is connected as one of the ratio arms of a Thomson bridge. The voltage drop is an indication of the temperature of the Pt-100 probe ($-50^{\circ}\text{C} \dots +200^{\circ}\text{C}$) and is applied to the ADC for measurement.

circuit element principles:

Thomson bridge:

The temperature probe (resistance thermometer) is included in one arm of a balanced resistive 4-wire bridge. The balancing potentiometer is R708; the slider connects the output of the bridge directly to the ADC.

In this configuration, the small resistances of the connecting leads are counter-acted; they are either in series with the current source or in series with the much higher resistance arms of the bridge, so their effect is negligible.

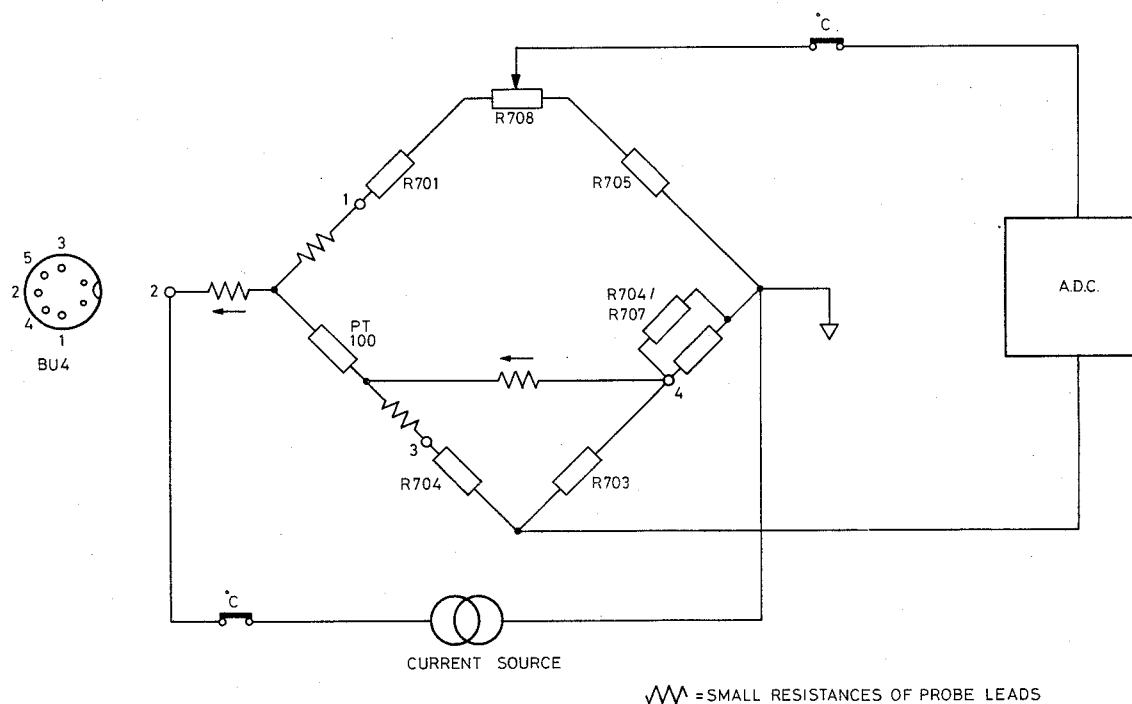

Fig. 8. Thomson bridge

1.3.3. Analog section (extended measurements).

1.3.3.1. Frequency measurements

The unknown frequency source to be measured is applied to the V and 0 input terminals. After suitable attenuation as necessary in the a.c. voltage attenuator and impedance conversion (to match the low-impedance comparator) the signal is fed to one input of the comparator A502.

The trigger level input selected by the front-panel thumbwheel control is applied via an impedance convertor to the other input of the comparator.

The trigger level is set to a value lower than the amplitude of the signal to be measured. During counting, each time the amplitude of the signal from the input exceeds the selected trigger level, the comparator gives an output pulse to the counter. The internal counter of the μ P is also used as an overflow counter for frequency measurements.

Triggering is also possible on the negative-going pulses of a signal by using the +/– switch to reverse the polarity of the trigger level.

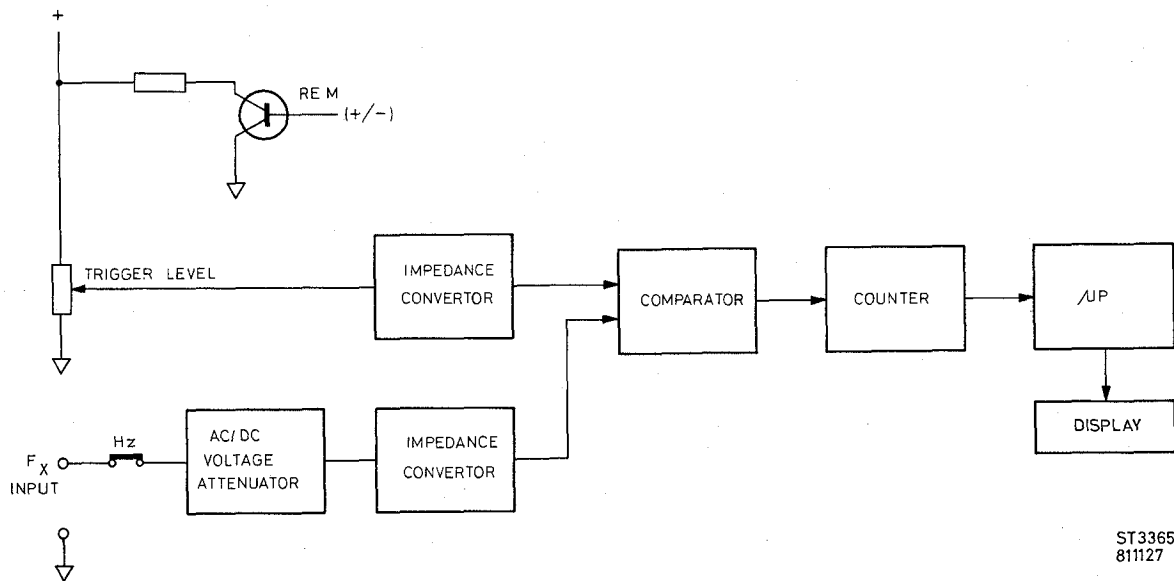

Fig. 9. Block diagram-frequency measurements

1.3.3.2. Time measurements

Time measurements of signals are determined in conjunction with the trigger level function in a similar way to frequency measurements.

The input signal is applied via the voltage attenuator to one input of the comparator A502. The selected trigger level is applied to the other input.

When the amplitude of the signal exceeds that of the selected trigger level, an output pulse from the comparator is applied direct to the microprocessor.

Two trigger modes are possible for the time measurement function:

In the normal trigger mode, signals that are higher or lower than the circuit zero (0 terminal of PM2521) can be triggered with the + or - trigger level respectively.

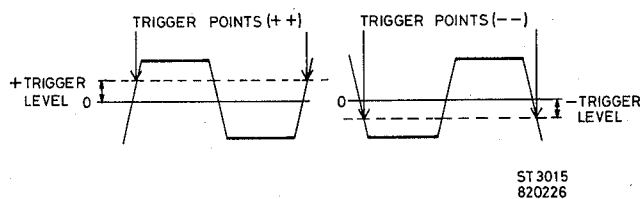

Fig. 10. Normal trigger mode

In the special trigger mode, using Data Hold Probe PM9263, the PM2521 triggers in the + level mode on positive and negative crossings of the trigger level.

Conversely, in the - level mode it triggers on negative and positive crossings of the trigger level.

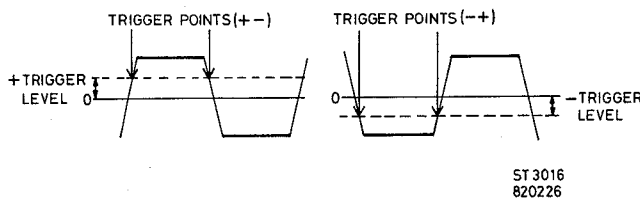

Fig. 11. Special trigger mode

1.3.3.3. Trigger measurements

In addition to time and frequency applications, the trigger level function permits other selective measurements to be made.

To measure the peak voltage of an input signal the front-panel trigger level control is rotated until the GATE indicator display is triggered either on or off. At this switch-over point the voltage indicated on the display represents the amplitude or peak voltage of the input signal.

1.3.4. Analog section (multifunction circuits)

1.3.4.1. R.M.S. convertor

Basically, the circuit is an a.c. to d.c. convertor built around the OQ0061 IC, which consists of three parts:

- A voltage-to-current convertor with two selectable input ranges
- A current rectifier with offset cancellation
- A log-antilog calculating R.M.S circuit

Circuit element principles:

As shown in Fig. 12, the basic V-to-I convertor consists of two input devices T1, T2 fed from two equal current sources and a conversion resistor R. The voltage $V (= V_{in1} - V_{in2})$ developed across R gives a current $I = \frac{V}{R}$ through R. This current increases the emitter current of T1 and decreases the emitter current of T2.

This results in collector output currents of $I + \Delta I$ for T1 and $I - \Delta I$ for T2.

Then the current is rectified to give a signal proportional to the R.M.S. value of the input signal V_{in} .

In practice, a more complex circuit is used to compensate for the differences in base-emitter currents.

The two equal currents I are derived from a current bias source.

For electronic range selection, two V-to-I convertors are used with common input and output devices but with separate conversion resistors.

The selection circuit for these has a selection input and a selection reference input that can be connected to various d.c. levels to give more control flexibility.

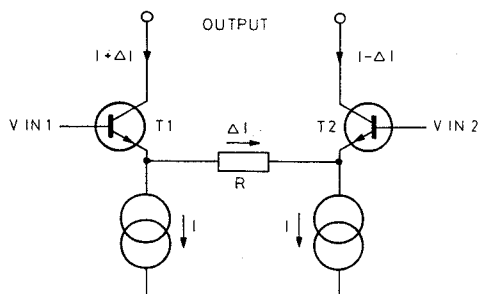

ST3366
811126

Fig. 12. Basic V-to-I convertor

1.3.4.2. Impedance convertor

The impedance convertor converts the high input impedance signal to a low impedance to match the input of the R.M.S. convertor.

This impedance matching also applies to the input of the trigger level comparator, as otherwise it would draw current from the signal.

1.3.4.3. Active filter

Filters placed in feedback loops around an amplifier stage are referred to as active filters. They have sharper transition between the pass-band and stop-band than their passive counterparts, inductors are not needed, and small signals are not further attenuated.

In this application, good filtering is necessary especially when measuring small a.c. signals.

In this circuit, the basic active filter elements are as shown:

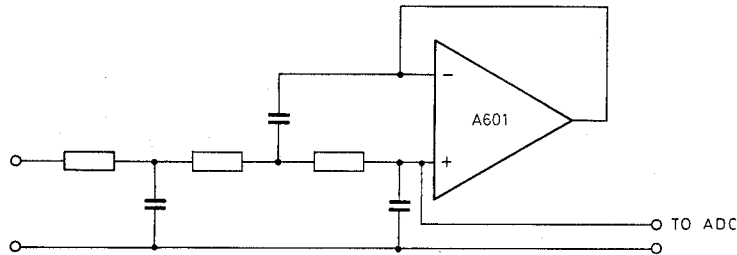

Fig. 13. Low-pass active filter

ST3367
820503

In the PM2521, the track shielding network on the filter output keeps the two signal lines that are connected to it at the same potential; i.e. prevents tracking across the p.c.b. insulation.

1.3.4.4. Analog-to-digital Convertor

The ADC converts the analog signal into a digital signal by the 'delta-modulation' principle.

Basically, the delta-modulation ADC counts the difference in the time taken to charge and to discharge a capacitor about a fixed level, over a fixed period of time.

The number of charge/discharge cycles within this fixed time depends on the charge/discharge current which is made proportional to the unknown input voltage to the ADC.

Therefore, the number of pulses counted within a fixed measuring period is proportional to the unknown voltage V_x .

Circuit principles:

The capacitor is charged by a constant reference current added to the constant current derived from V_x to give $(I_{ref} + \Delta I)$.

The capacitor is discharged by the constant reference current minus the constant current derived from V_x to give $(I_{ref} - \Delta I)$.

Each value of V_x has a certain number of charge/discharge cycles within the fixed period of a specific number of clock-pulses counted by a timer.

The fixed level between charging and discharging is determined by the voltage between the inputs of a comparator ($\approx 0V$) a flip-flop and clock signals.

A simple example of the principle is shown in Fig. 14.

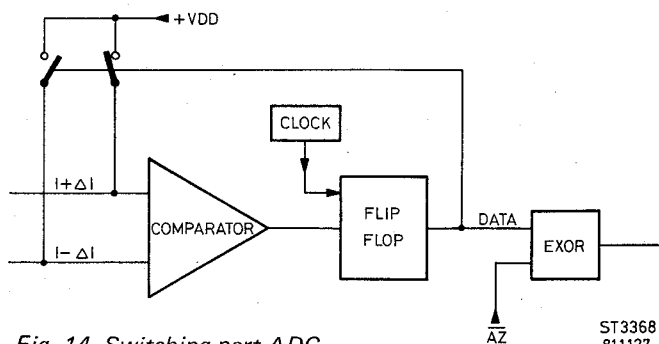

Fig. 14. Switching part ADC

ST3368
811127

When the fixed level is reached, the comparator switches and on receipt of the next clock-pulse the flip-flop changes its state. The flip-flop output is fed back to control the switches that connect the charging current ($I + \Delta I$) and the discharging current ($I - \Delta I$) to the capacitor. The ADC output (DATA) from the flip-flop is a square-wave, the duty-cycle of which is determined by the charge/discharge times. This is routed to a counter together with the clock pulses.

During the logic 1 state of the data signal the clock pulses are counted.

To obtain automatic zero, i.e. to counteract drift and internal offset, one complete measurement consists of two fixed measuring periods. This auto-zero function is carried out with the aid of the AZ and \overline{AZ} signals from the control logic.

When a measurement is started (1st. measuring period), the unknown voltage is supplied to the + input of the OQ0064 while the - input is connected to zero. The signal which is converted will be $+V_{in} + V_{off}$; i.e. $I + \Delta I_1 + \Delta I_2$ (ΔI_1 is caused by the input voltage, ΔI_2 is caused by the offset).

In the second measuring period, the input signal is connected to the - input while the + input is now connected to zero. This signal which is converted, will be $-V_{in} + V_{off}$; i.e. $I - \Delta I_1 + \Delta I_2$ (ΔI_1 is caused by the input voltage, ΔI_2 is caused by the offset).

The results of the two measurements are subtracted and divided by two:

$$\begin{array}{r} I + \Delta I_1 + \Delta I_2 \quad \dots \text{1st. measurement} \\ I - \Delta I_1 + \Delta I_2 \quad \dots \text{2nd. measurement} \\ \hline \end{array}$$

$$2\Delta I_1 \quad \text{which divided by two} = \Delta I_1 \text{ the counted value for display.}$$

1.3.5. Control section (Refer to Fig. 18.)

1.3.5.1. Microprocessor 8035

The integrated circuit microprocessor 8035, one of the MCS-48 family of single-chip microcomputers forms the basis of the control section of the PM2521 automatic multimeter. The 8035 is the equivalent of the 8048 except that it has no internal program memory.

However, it uses two externally-located read-only memories (2kx8-bit EPROM's) with address/data decoding facilities for program instruction storage.

In addition to the true bidirectional 8-line databus, the 8035 has two quasi-bidirectional 8-bit data ports for extra address lines and communication with the external circuits in the PM2521. Data written to these ports remains unchanged until rewritten. Each line is able to serve as input or output, or both, even though outputs are statically latched.

The internal data memory is a random-access store of 64x8-bits, indirectly addressable through the RAM pointer register.

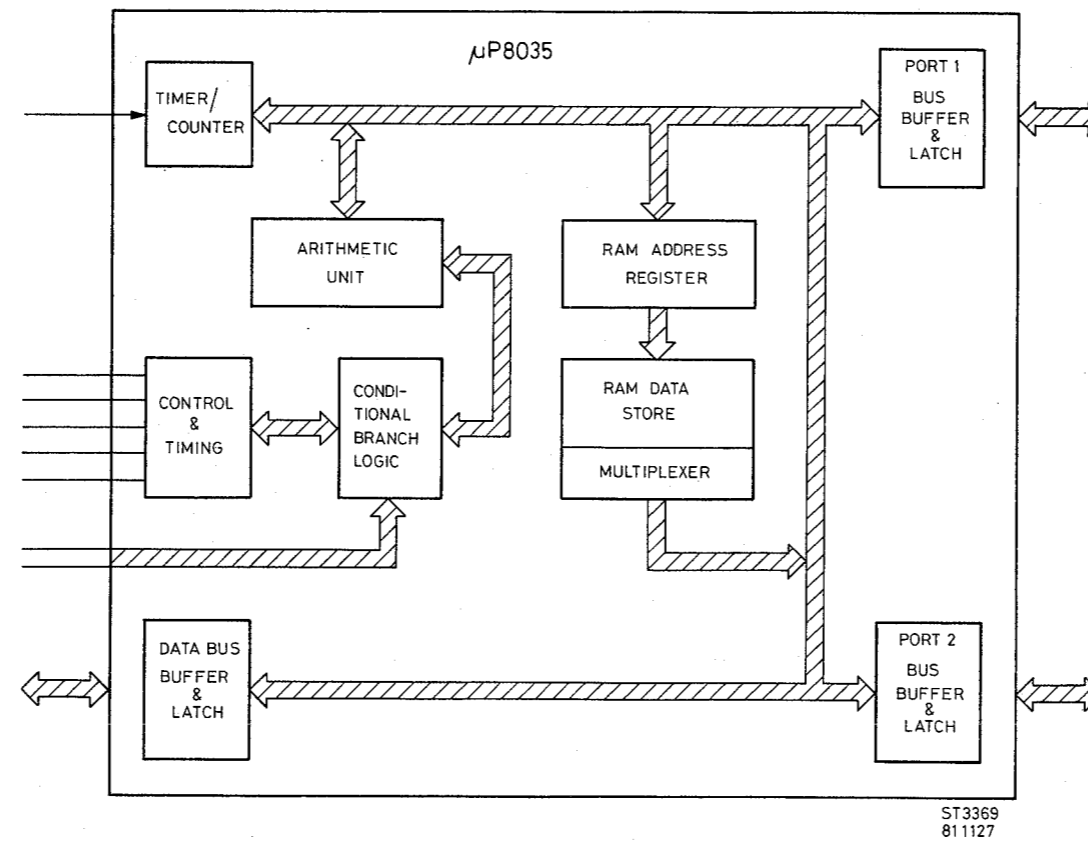
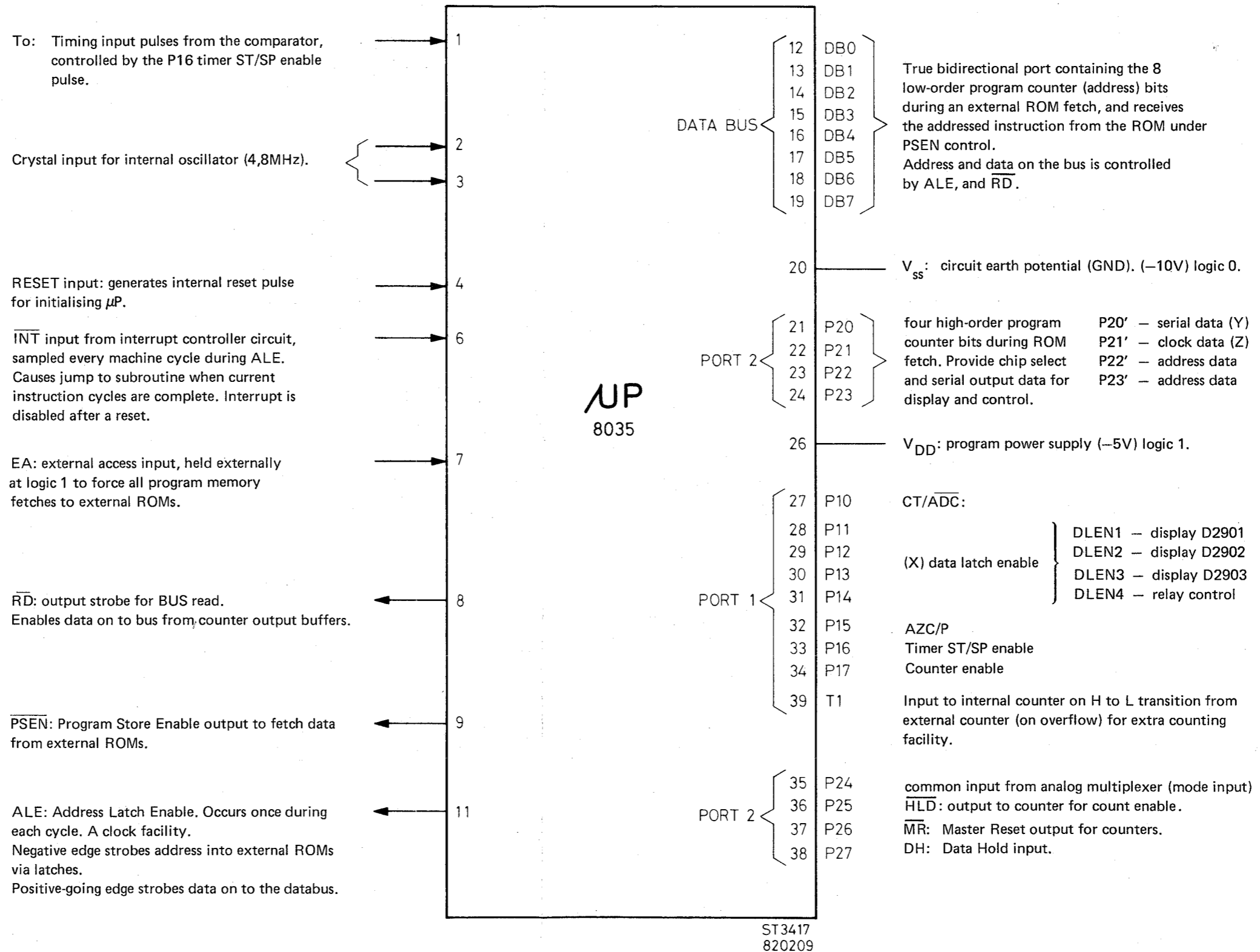

Fig. 15. Basic functional blocks of 8035 μ P.

The following part gives an indication of which pins are used in the PM2521.



ST3417
820209

Fig. 16. Pin allocation & functions of 8035 μP

1.3.5.2. Interrupt controller

The interrupt controller activates the microprocessor interrupt input facility to allow certain subroutines to be performed either by manual or automatic control. The control inputs are interrupt pulses applied from either one of the four front-panel mode switches or from timing pulses generated from the comparator output in the timing mode.

a) Mode switch interrupts

The logic 0 required for interrupt is derived from one of the four mode pushbuttons. It provides for: UP and DOWN ranging in the manual mode, AUTO ranging (except in timer function).

- Trigger mode polarity selection
- Selecting relative reference with ZERO SET in V \dots , dB, Ω , and $^{\circ}$ C range
- Manual STOP/RESET in timing mode

The functional circuit for interrupts given by the mode switches is shown below:

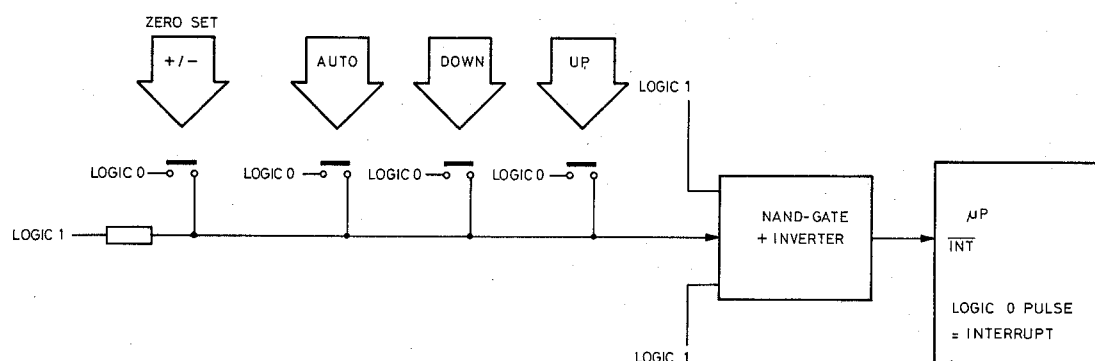

Fig. 17. Mode switch interrupts

ST3370
811127

Normally the three inputs to the NAND-gate are at logic 1, and the double inversion of the NAND-gate + the inverter gives a logic 1 at the $\overline{\text{INT}}$ input of the microprocessor; i.e. no interrupt is given.

However, when one of the four pushbuttons is depressed momentarily, a logic 0 pulse is given to the middle input shown, which results in a logic 0 being applied to the $\overline{\text{INT}}$ input, the condition for interrupt.

b) Trigger level interrupts

In the timing measurement mode, interrupts are generated by the trigger level circuit via the comparator for starting and stopping the μP internal counter during time measuring.

In the **normal trigger mode**, by the use of delays and exclusive-OR gating, logic 0 outputs are generated on the positive-going crossings of the trigger level; i.e. an interrupt is given at the leading edges of successive comparator output pulses to start and stop the μP counter.

In the **special trigger mode**, a logic 0 applied from the data hold probe switch enables timing of the duty-cycle of an input by stopping the timing period at the negative crossings of the trigger level. In this case, the leading edge of the comparator output pulse starts the μP counter and the trailing edge stops it.

When the negative trigger level is selected, the start/stop polarities will be the reverse.

1.3.5.3. Counter

The counter receives logic input pulses from the ADC output, or from the comparator output when measuring in the frequency mode.

Selection between the two inputs is made in the counter input control stage by a control signal from the microprocessor.

The counter itself consists of two high-speed 4-bit binary counters in cascade which give an 8-bit output via buffers to the databus.

When measuring frequency, additional counting capacity is provided by the internal counter of the microprocessor.

a) Counter input control

The data input from the ADC is the varying duty-cycle pulses that represent the charge-discharge cycle of the integrator capacitor. In the counter the result of the first measuring period is obtained; i.e. the number of clock-pulses passed during the charge parts of the cycles. At the end of this period the μP timer carry signal AZ changes the state of the control logic and also reverses the input voltages to the ADC to compensate for any zero drift. A second measuring period follows and the resultant measurement is the mean of the two periods.

The data input from the comparator consists of logic pulses representing the frequency measurement. These are gated to the counter when a logic 1 is sent from the μP on the CT/ADC line. In this measuring function, the data input path from the ADC is inhibited.

b) Counter output control

Whatever input is selected, the counter reads in the pulses after it is reset and enabled by the μP control. The 8-bit output is connected to output buffers and applied to the databus when the counter output is enabled by the microprocessor.

In the frequency measuring mode the most-significant output bit from the counter is routed to the T1 input of the microprocessor to use the internal counter as extra capacity in the event of overflow.

1.3.5.4. Analog control

The analog control section can be divided into two parts:

- The inputs to the microprocessor that indicate the status of the analog section
- The output circuits of the μP that control the analog section according to the settings of the function selector and the inputs from the mode switches and signals to be measured.

a) Control inputs

The various inputs to the control section provide the means for the μP to sense the control requirements for a particular measurement situation.

These inputs include:

- The function selector switch position
- The manually selected mode switches
- The counter output (display and status condition, e.g. overload)
- The ROM program, or software control inputs

The mode switches and the function selector are scanned under software control, from the μP and the ROM program, in a multiplexer stage and the output conditions detected are fed serially to the μP as logic control signals.

b) Control outputs

The microcomputer controls the analog section, in accordance with the input information received, by means of reed relays and FET switches. The output data is clocked into a relay control unit which supplies function and range information to the analog section for switching purposes. Additional outputs are set/reset commands for the timing measurements, trigger level, dB conversion, and ZERO SET command for the relative reference value.

1.3.5.5. ROM's and address/data decoding

The program memory for the microprocessor is stored in two 2k ROM memories. During an instruction cycle, data is fetched from the ROM's by the μP . This requires that the ROM locations are first addressed whereupon the ROM responds by sending the instruction or data to the μP . The addresses for the ROM's are decoded from data sent out on the 8-bit databus lines and the high-order program lines from port 2 of the microprocessor. These additional program lines are used to extend the address capability of the bus. The decoding is achieved by bistable latches controlled by the ALE (address latch enable) output of the μP . The data output from the ROM's is controlled by the \overline{PSEN} (program store enable) signal from the μP , which is gated to give a chip select signal to either ROM depending on the stated of the signal line P23.

1.3.6. Display section

The display section of the PM2521 contains three LCD (Liquid Crystal Display) interface integrated circuits that accept serially clocked output data from the μP to drive the display.

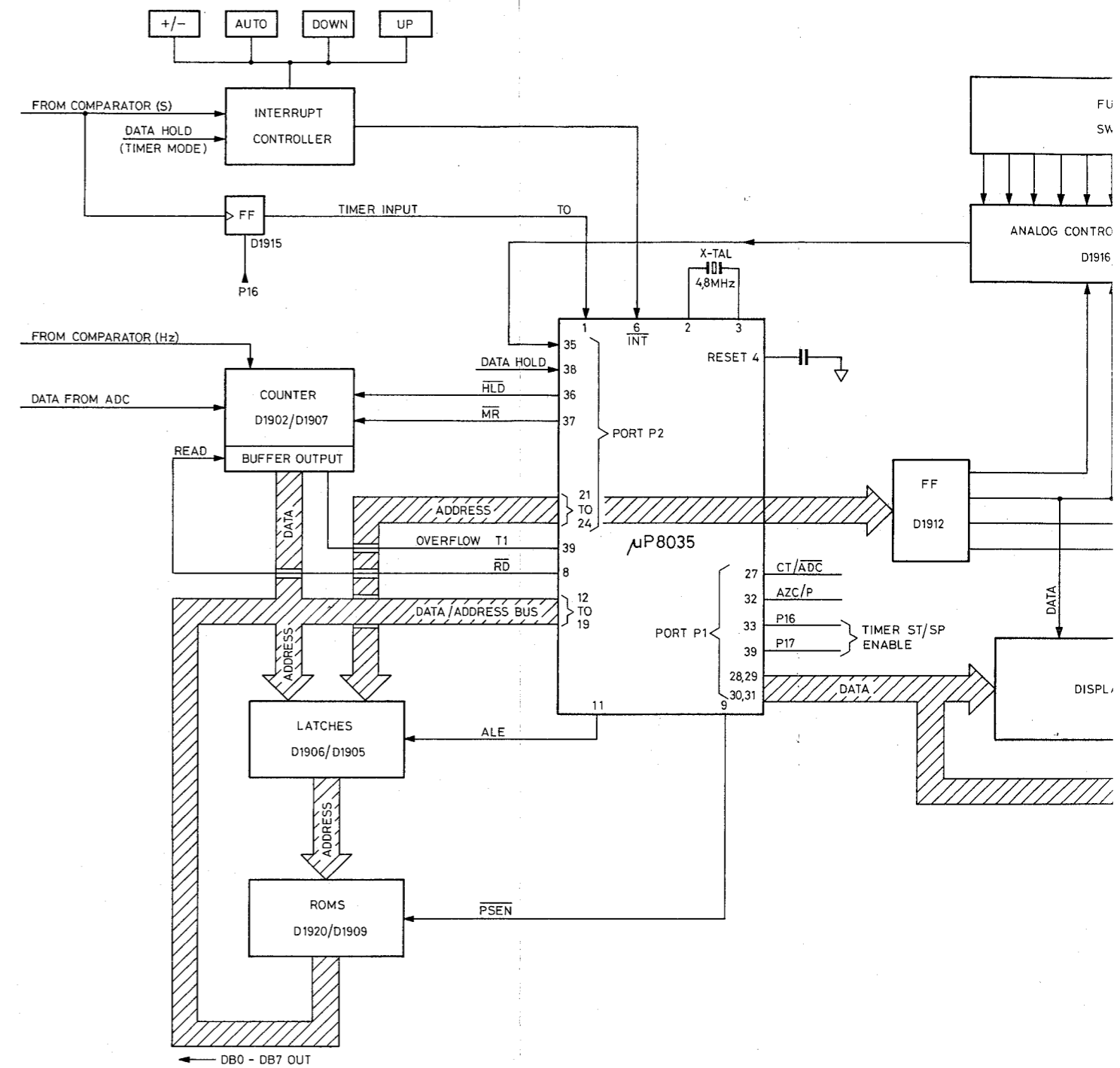

ance with the input information received, by
s clocked into a relay control unit which supplies
witching purposes. Additional outputs are
level, dB conversion, and ZERO SET command

o 2k ROM memories.
by the μP .
reupon the ROM responds by sending the

on the 8-bit databus lines and the high-order
tional program lines are used to extend the

e ALE (address latch enable) output of the μP .

(program store enable) signal from the μP , which
on the stated of the signal line P23.

aid Crystal Display) interface integrated circuits
the display.

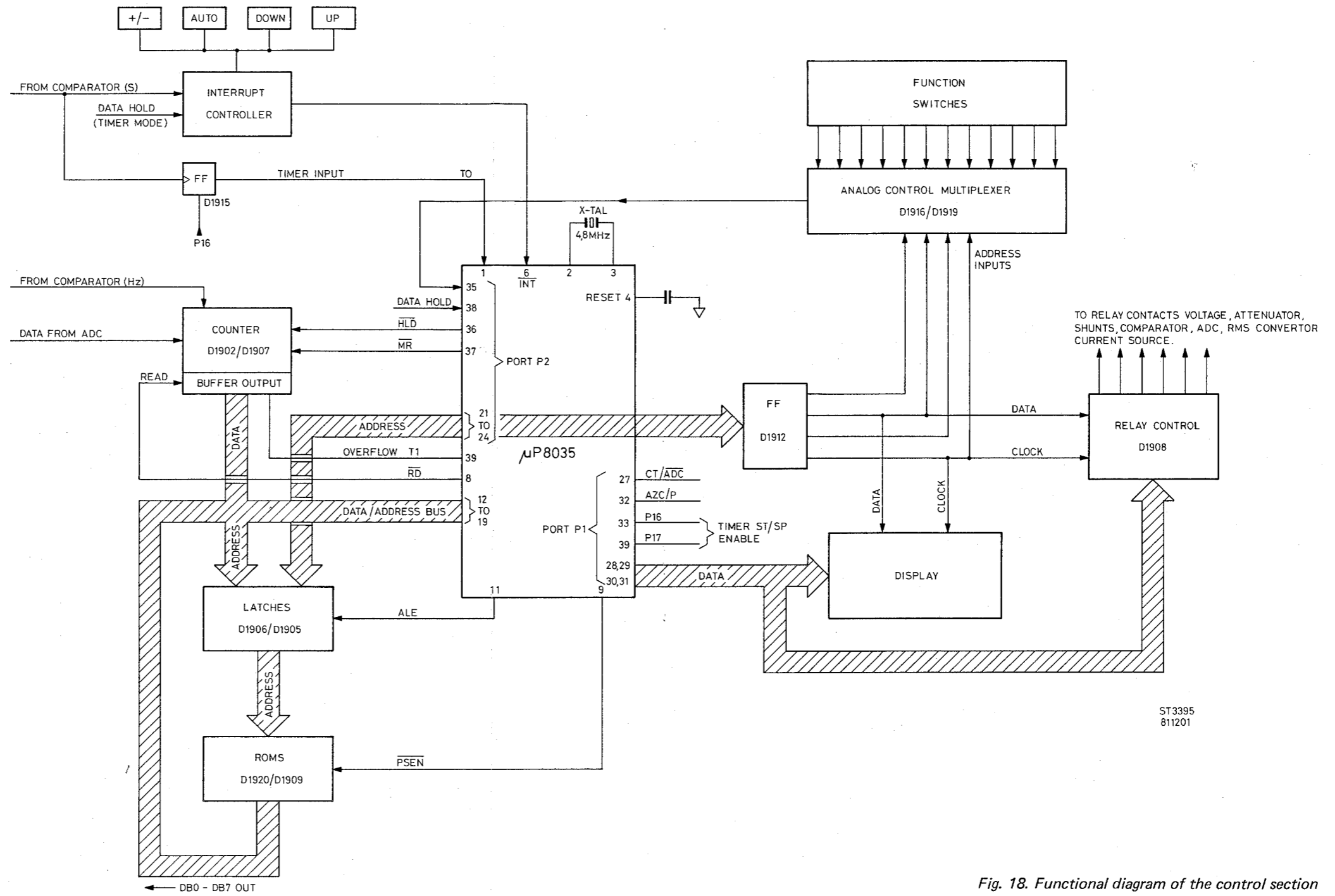

Fig. 18. Functional diagram of the control section

1.4. DETAILED CIRCUIT DESCRIPTION

1.4.1. Measuring sequence

After POWER ON, the PM2521 carries out some routines to measure and evaluate the input signals applied. The software applications are briefly indicated by the following sequence.

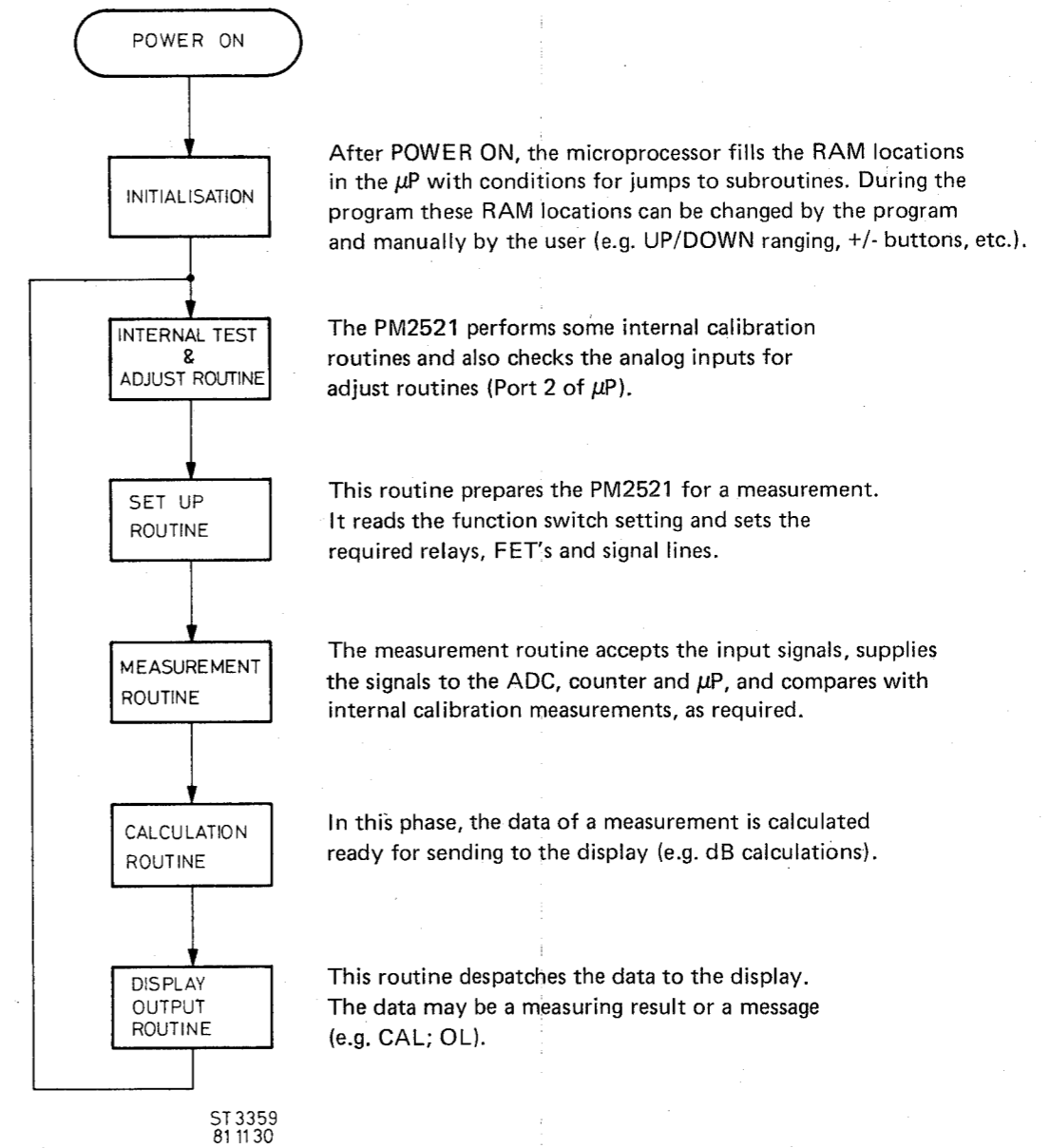

Fig. 19. Measuring sequence

1.4.1.1. Initialisation

In this phase the μP fills the internal RAM locations as an instruction reference for the μP . For example, if the AUTO bit is set, then the μP knows that AUTO-RANGING is selected. The values of a measurement or a calibration measurement are also saved in these registers.

PROGRAM MEMORY CONTENTS (for example)

ADDRESS DECIMAL	BIT POSITION								
	7	6	5	4	3	2	1	0	
20				IT	OUT	CALC	MEAS	SUP	ZMON
21	~	°C	Ω	V	A	s	Hz	Trigger level	YFU
22						RM2	RM1	RM0	YRM
23						Mauto	Rdown	Rup	YRSC
24						M2	M1	M0	YMN
25	M7	M6	M5	M4	M3				
26									
27									
28		dB	gate	Zero S	Lobat	CAL	OL		YDM
29									
2A	B7*****BINARY RESULT*****B0								
2B	B15*****B8								
2C				POS				***B16	

ZMON = Monitor (which routine?) IT = initialisation
 OUT = display output routine
 CALC = calculation routine
 MEAS = measurement routine
 SUP = set up routine

YFU = Function (which function?)
 YRM = Range meter (which range ?)
 YRSC = Range control status (up,down or auto ranging)
 YMN = Measurement number
 YDM = Display mode (which symbol to the display?)

1.4.1.2. Internal Test and Adjust Routine

After initialisation, the PM2521 performs two series of measurements as shown in the following flow-chart.

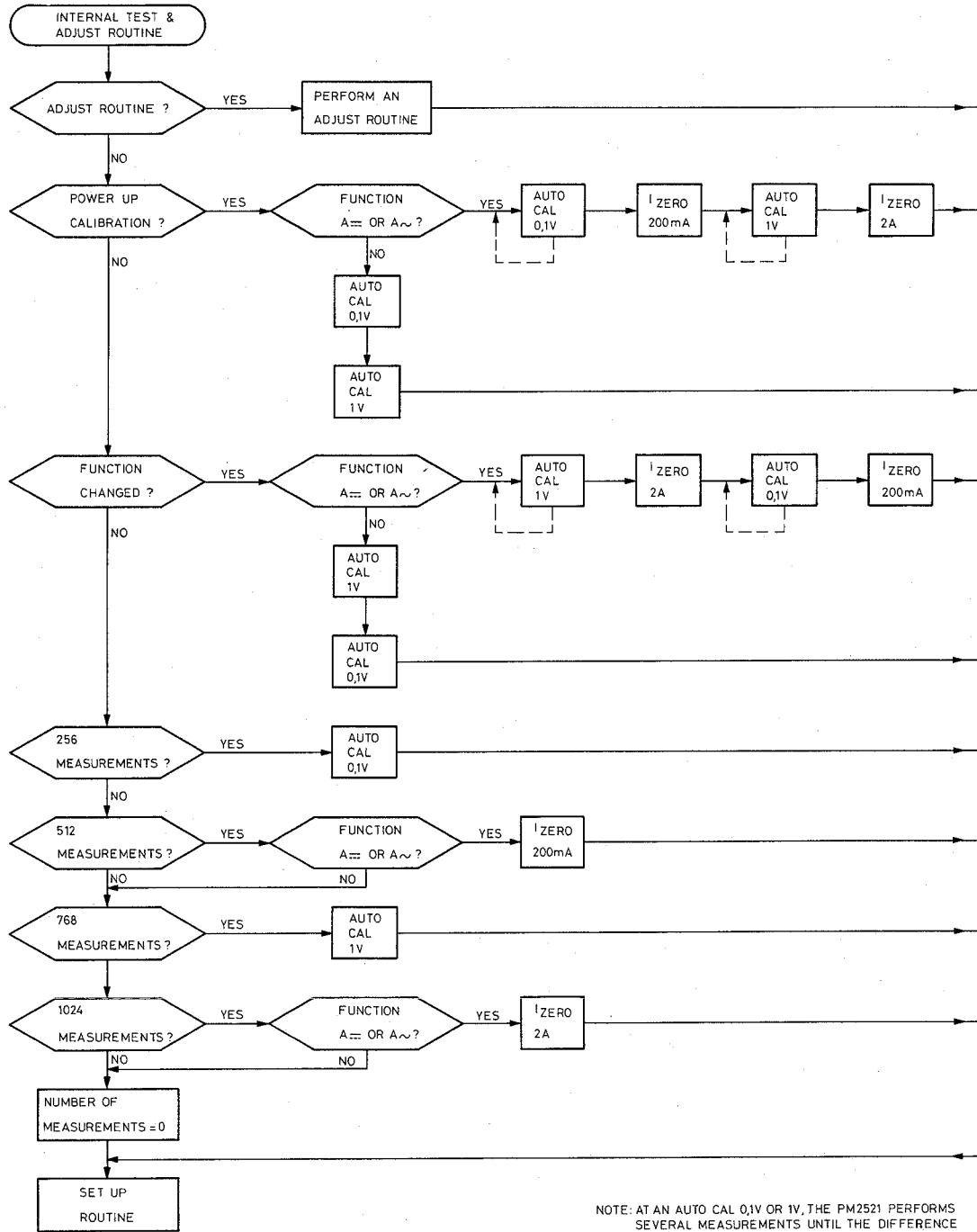

NOTE: AT AN AUTO CAL 0,1V OR 1V, THE PM2521 PERFORMS SEVERAL MEASUREMENTS UNTIL THE DIFFERENCE BETWEEN TWO MEASUREMENTS IS ≤ 1 DIGIT.

S13372
811130

Fig. 21. Flow-chart internal test and adjust routine

- a) An AUTO CAL 0,1V measurement
- b) An AUTO CAL 1V measurement

When making the AUTO CAL 0,1V measurement the μP programs the OQ0063 so that a current of $100\mu A$ flows through R606, which causes a voltage drop of $100mV$ across it ($100\mu A \times 1k\Omega$). This voltage is supplied to the ADC and is counted by the μP , stored in a RAM location and used as reference for a normal measurement.

When making the AUTO CAL 1V measurement, the μP programs the OQ0063 to give a current of 1mA through R606. The resulting 1V across R606 is also counted and stored in a RAM as a reference for further measurements. In this case, a different sensitivity of the ADC is chosen (i.e. 1V).

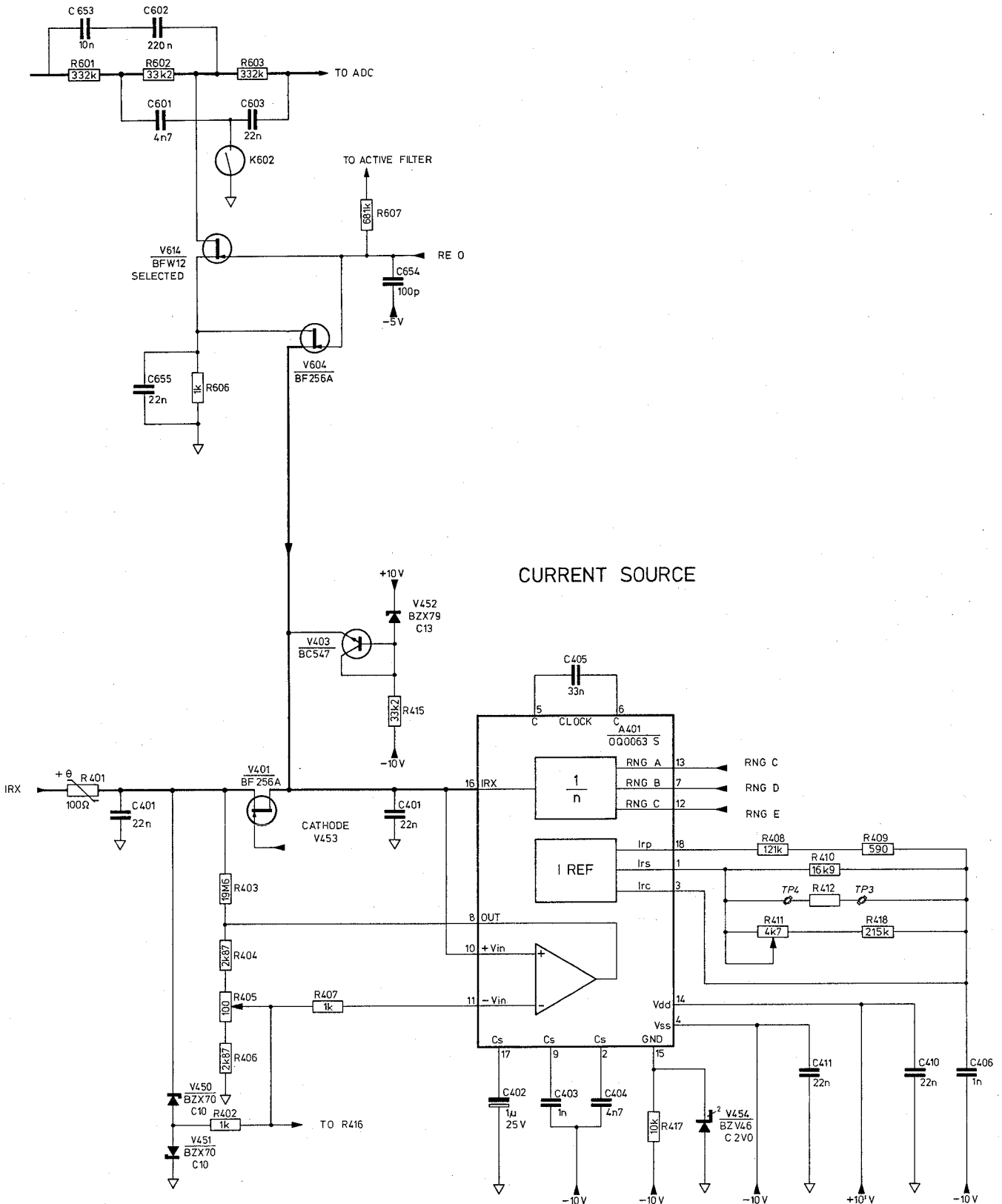

Fig. 20. Calibration routine

In the function selector positions A \approx or A \sim two offset measurements are performed.

- a) A 200mA I zero measurement (offset)
- b) A 2 A I zero measurement (offset)

The PM2521 measures the offset in the I to V convertor and this is subtracted from the result of a normal measurement in these two ranges.

All the above measurements are completely controlled by the microprocessor software. The following sub-routines are used for internal test and adjust routines:

- Comparison routine
- Fetch adjustment number routine
- Fetch calibration value routine

Also used as subroutines:

- The set-up routine
- The measuring routine
- The calculation routine
- The display output routine

Comparison routine:

Here the contents of a calibration measurement are compared with a normal measurement. If the contents of both are equal then an internal bit is set.

Fetch adjustment number routine:

The μP scans port P11 and reads the number of the adjust mode.

k = adjust mode 1 * blinks
 Z = adjust mode 2
 S = adjust mode 3

Fetch calibration value routine:

Fetches the calibration value (i.e. the measuring time) from the low calibration value register and the high calibration value register and transfers it to the binary result register.

1.4.1.3. Set up routine

The set up routine uses the following subroutines:

Start-up routine:

This routine checks if the POWER ON bit is set and if so, it sets the relays for the internal calibration.

Refresh routine:

This routine reads the function switch until a function is located and then updates the function register. Then it reads the A-bus switch, the automatic bit, the LO BAT input and the DATA HOLD input. It also checks if the function switch has been changed and if so, it makes the necessary calibration measurements.

Range routine:

When an UP or DOWN ranging button is depressed a bit is set in the range control status register. This routine checks this bit and performs the required ranging.

Set up execution routine:

This routine shifts the data for the relay settings in the D1908 (SAA1060) and also controls the timing for shifting.

Check routine:

The check routine examines the Rdown and Rup bits in the range control status register. If the range $>$ range max. then the instrument must range up. If the range $<$ range min. then the instrument must range down. It also ensures that in the TRIGGER LEVEL function only manual ranging is allowed.

1.4.1.4. Measurement routine

The measurement routine uses the following subroutines:

ADC measuring time routine:

This routine is responsible for the whole timing of the ADC (see OQ0060 and OQ0064).

Counter measurement routine:

The frequency measurements are performed without the ADC. This routine controls the circuits that in turn control the frequency functions.

Timer routine:

For timing measurements in position s, this routine controls the timing functions. It checks for the SET/RESET pulse and the STOP bit.

BCD conversion routine:

The value counted is converted to BCD information by this routine.

1.4.1.5. Calculation routine

The calculation routine uses the following subroutines:

Fast measurement calculation routine:

After a fast measurement, the PM2521 performs a fast calculation for the purpose of ranging.

Slow measurement calculation routine:

This routine converts a slow measurement result into display data and calibration data.

The calibration data is made to compare two results. The display data is made to shift the data into the SAA1060.

1.4.1.6. Display output routine

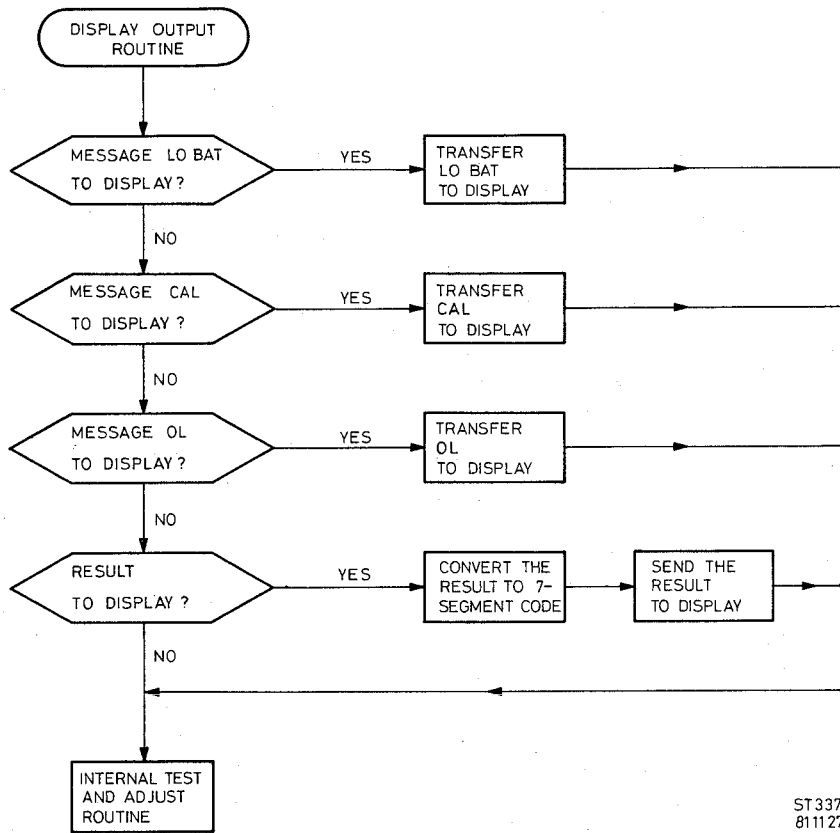

ST3374
811127

Fig. 22. Flow-chart display output routine

1.4.2. Analog section

1.4.2.1. Direct voltage measurements (V...)

The input circuit for the d.c. voltage measurements is shown in Fig. 23.

The various ranges are selected by reed relay switches, which connect resistors in parallel with the basic attenuator. The table indicates for each range the attenuation factor, the ADC input sensitivity and the range relays.

The basic x 2 attenuation is given by the network comprising the series R101 section, and the shunt path R101, R103, R106.

Adjustment of the basic x 2 attenuation is made by the preset potentiometer R103.

Preset R108 across the +10V and -10V supply provides d.c. balance.

The 200mV sensitivity is achieved by using the 100mV range of the ADC, which is activated by the RNGB input from the relay control D1908.

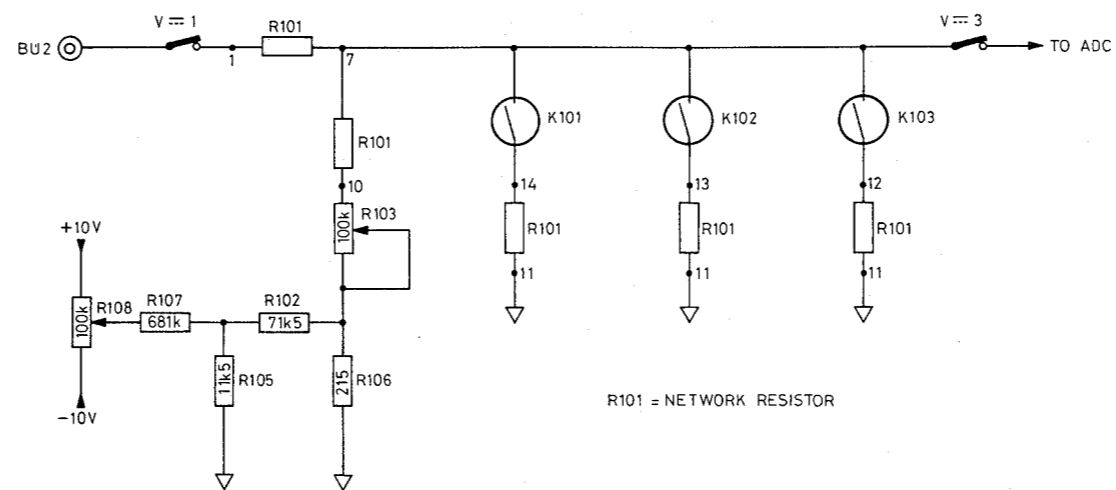

ST3375
811130

Fig. 23. D.C. attenuator detailed

RANGE	ATTENUATION	ADC in. RANGE	RELAY
200mV	2 (RNGB)	100mV	
2 V	2	1 V	
20 V	20	1 V	K101 ReA
200 V	200	1 V	K102 ReB
2000 V	2000	1 V	K103 ReC

1.4.2.2. Alternating voltage measurements (V~)

a) Input a.c. attenuator

The input circuit for the a.c. voltage measurements is shown in Fig. 24.

The table indicates the attenuation factor ADC sensitivity, and range relays and components.

The basic x 2 attenuation is given by the voltage division of the series components R101//C101, C102 and the shunt components R101, R103, R106//C103, C104, C105. Any d.c. component at the input is blocked by C100.

- x 20 attenuation is provided by R101//C106, C107, C108 switched by relay K101;
- x 200 attenuation by R101//C109, C110, C111, C112, C113, switched by relay K102;
- x 2000 attenuation by R101//C115, C116, switched by K103.

The preset capacity trimmers allow calibration of the different ranges.

RANGE	ATTENUATION	AC INPUT RANGE	RELAY
200mV	2	100mV (RNGA)	
2 V	2	1 V	
20 V	20	1 V	K101 ReA
200 V	200	1 V	K102 ReB
2000 V*	2000	1 V	K103 ReC

* max. input = 600V R.M.S.

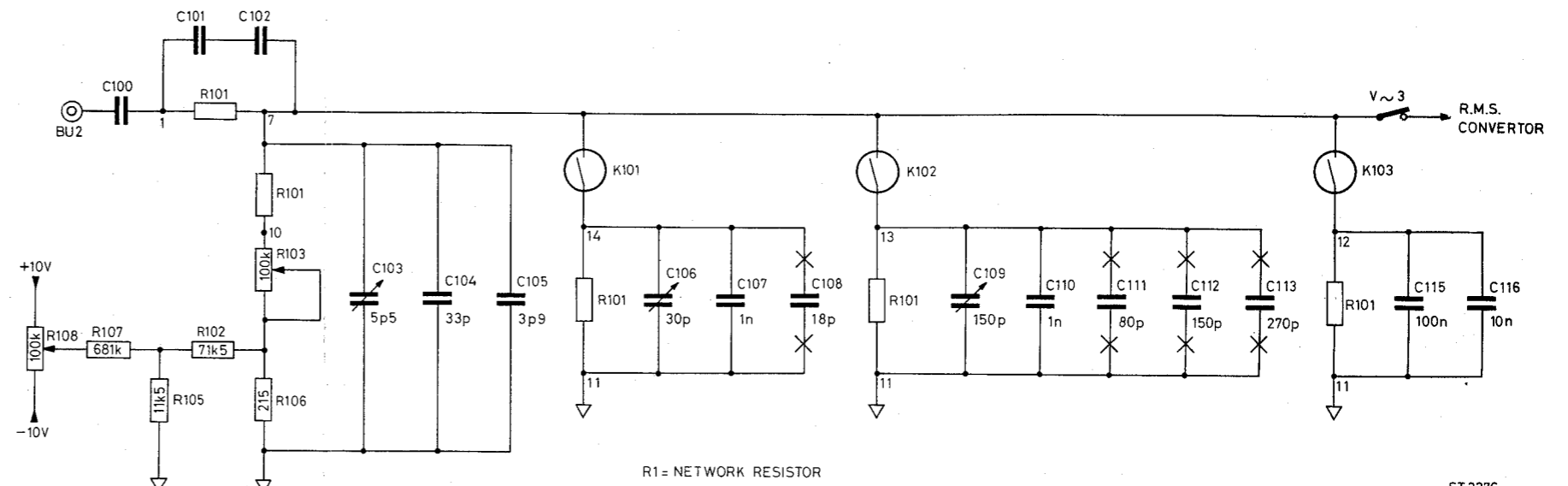

Fig. 24. A.C. attenuator detailed

ST 3376
811210

1.4.2.3. Direct current measurements (A ...)

Currents less than 20mA applied to BU2 are routed via the A ... function switch contact direct to the I-V convertor.

Any differences in polarity for zero input in the low current range can be offset by the preset R227. In the 0.2A to 10A ranges, the unknown current source applied to BU3 is shunted by R1 and routed via FET switch V201 and the resistors R203, R204//R205 to the input of the I-V convertor amplifier A201. The initial offset routine for the high current ranges is performed by software, controlling the RNG C input. During this routine the input current on BU3 is isolated by a logic 1 in RNG C which switches off V205 and consequently FET switch V201. The logic 1 is also applied to the gate of FET V202 to earth the input to the I-V convertor for the zero offset routine.

The high current input is protected against overloads by the diodes V259, V260.

The BU3 input connector, when inserted, links the input socket with the base of transistor V206, which sends a logic 0 to the A-bus of the switch decoding multiplexer, to signal that the high current ranges have been selected.

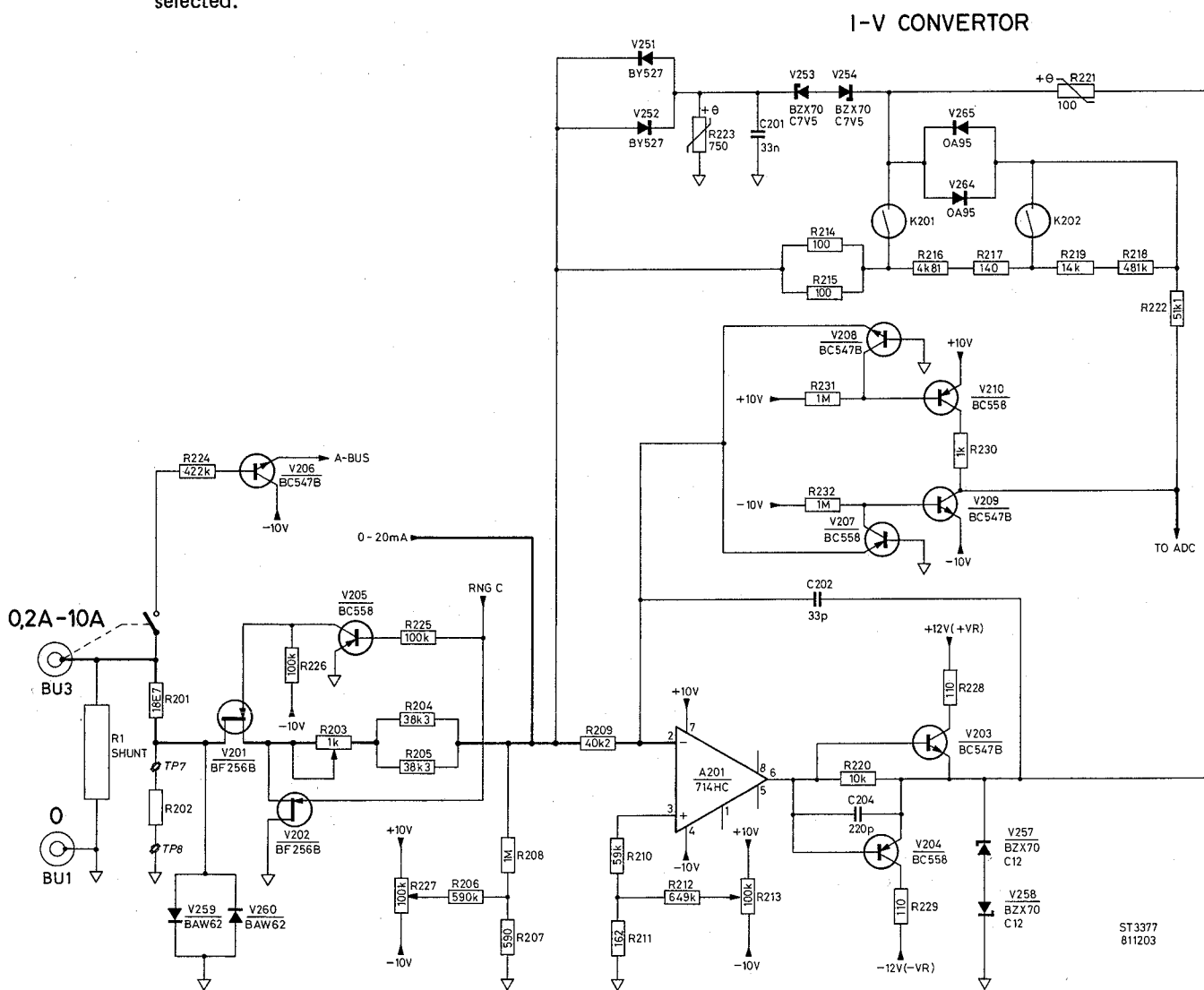

Fig. 25. I-V convertor

The principle of the I-V convertor is explained in the functional description.

The operational amplifier A201 is a shunt feedback amplifier that converts the input currents into output voltages between 0 to 0,1V and 0 to 1V.

RANGES	ADC SENSITIVITY	RELAYS	MODE SIGNAL
2 μ A	1V		
20 μ A	0,1V	K202	
200 μ A	1V	K202	
2mA	0,1V	K201 + K202	
20mA	1V	K201 + K202	
200mA	0,1V		A BUS
2 A	1V		
20 A	0,1V		

The feedback resistors are selected according to the table by reed relay switches K201 and K202.

The two transistors V203, V204 take over the extra current from the operational amplifier A201, when the voltage across R220 exceeds 600mV.

The protection circuits for the I-V convertor are:

- Transistors V209, V210, which provide overload protection.
Normally the input of A201 is at virtual earth, but excessive negative inputs are prevented by V208, and excessive positive inputs are prevented by V207.
- Zener diodes V257, V258 which provide current protection.
- Protection diodes V253, V254 for the shunt feedback path in series with V251, V252, which are included to block the leakage current of the protection diodes.

The output from the I-V convertor is passed via the A \cdot 2 function selector switch to the active filter and the ADC.

1.4.2.4. Alternating current measurements (A \sim)

For alternating current measurements, the voltage output of I-V convertor is applied via the function selector switch A \sim 2 to the impedance convertor and the R.M.S convertor before being passed by reed relay switch contact to the active filter and ADC.

1.4.2.5. Resistance measurements (Ω)

The unknown resistance connected to the BU2 input is fed via the Ω 1 function selector switch contact to the voltage attenuator and is supplied with a constant current I_{RX} , via contact Ω 2, from the constant current source A401 (OQ0063).

CURRENT SOURCE

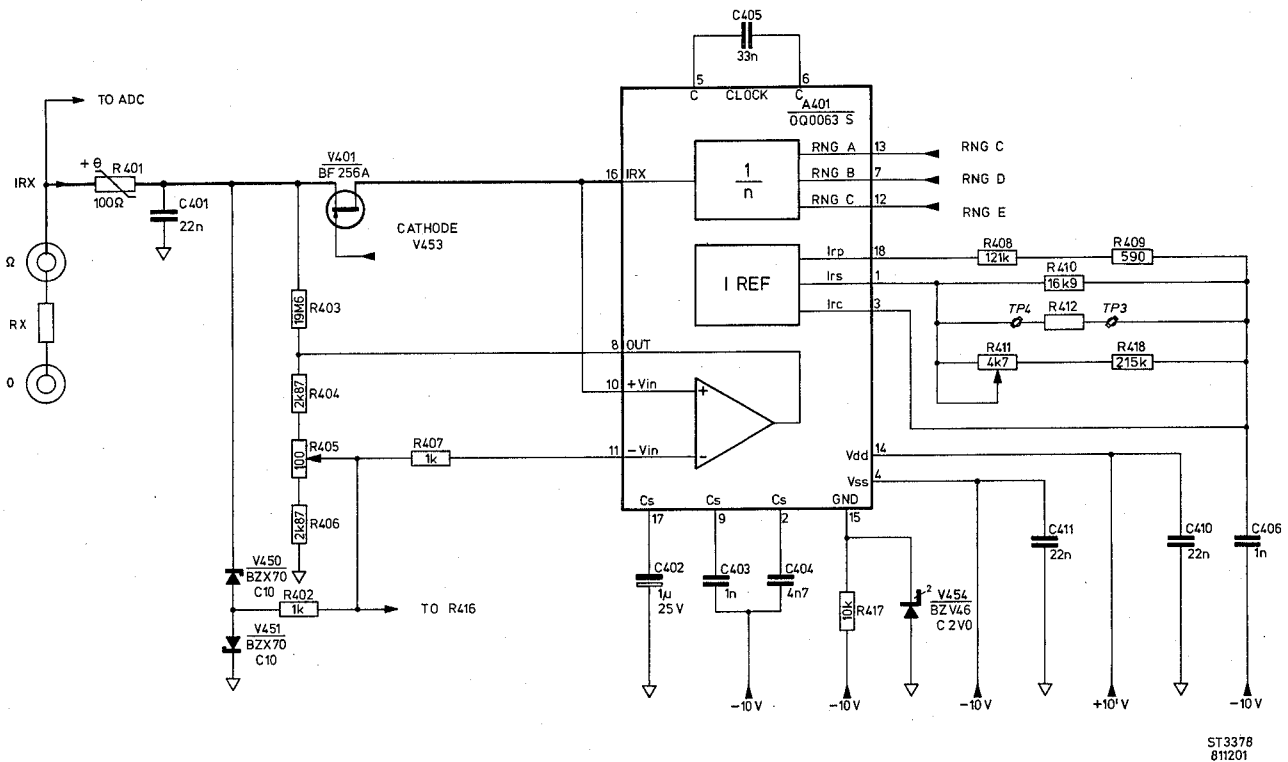

Fig. 26. Ω measurement details

The measuring currents in the OQ0063 are derived from a reference current source I REF adjusted by R418 in series with potentiometer R411. The output current I_{rc} of the reference current source feeds the current multipliers $\frac{1}{n}$ to give the currents I_{rx} shown in the table, depending on the selected signals RNGC, RNGD or RNGE.

As stated, the voltage V_x developed across R_x is applied to the ADC for measurement. However, the ADC input resistance is finite ($10M\Omega$) and the small input current drawn by the ADC has to be compensated to avoid incorrect readings.

This is achieved as follows:

The voltage V_x across R_x is amplified by a factor of 2 in the compensation amplifier (+Vin), the gain being determined by the equal resistors R404, R406.

The output voltage of $2V_x$ appears at one end of R403 and V_x is present at the other end. The voltage across R403 is therefore:

$$2V_x - V_x = V_x \quad \text{As } R403 = \text{the input resistance of the ADC } (10M\Omega) \text{ the input current of the ADC is compensated.}$$

In this way, the load imposed by the ADC is compensated as $I_{comp} = I_{adc}$

$$I_{rx}' = I_{rx} + I_{adc} - I_{comp} \\ \text{so } I_{rx}' = I_{rx}.$$

Protection for the current source is afforded by the PTC resistor R401 and zener diodes V450, V451, V452 and diode-connected transistor V403.

In the event of a high voltage/current on the input terminals R401 goes high resistance. To prevent part of IRx leaking through the protection diodes, the emitter of V403 and the cathode of zener diode V450 are connected to Vx and the electrodes are routed back to the -Vin input of the compensation amplifier.

The leakage current through the diodes is therefore balanced out in the same way as compensation is achieved for the ADC input current.

1.4.2.6. Diode measurements

Diode measurements, and measurement of semiconductor junctions are performed in the same way as for resistance measurements in the $2k\Omega$ range. The value displayed is the voltage in forward or reverse direction across the diode in the 2V range.

In the diode measuring range, the constant current derived from the OQ0063 is 1mA (see previous section).

1.4.2.7. Temperature measurements ($^{\circ}C$)

When the $^{\circ}C$ function is selected, the constant current IRx is routed from pin 2 of the probe connector BU4, which is connected via the probe lead to one end of the PT100 resistance thermometer.

The output of the Thomson bridge is applied to the ADC via function switch contact $^{\circ}C2$.

The earth return to the ADC is routed to the common sources of V607 and V607'. This point is now raised above earth by the potential drop across the bridge caused by the measuring current source; i.e. 100mV for $0^{\circ}C$.

The Data Hold switch output is derived from pin 5 of BU4.

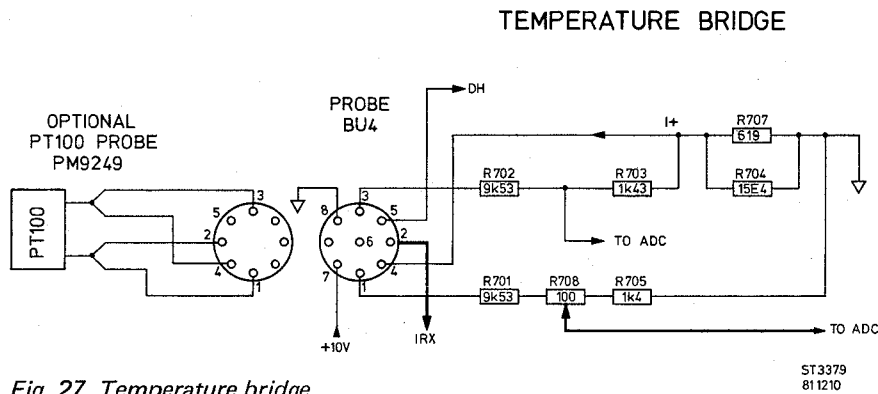

Fig. 27. Temperature bridge

1.4.3. Analog section (extended measurements)

1.4.3.1. Frequency measurements (Hz)

The Hz1 function switch connects the input signal to be measured to the voltage attenuator. After attenuation it is applied via function switch contact Hz2 to the impedance convertor. The low impedance output is applied to the + input of the comparator A502.

When positive triggering is selected, the +10V is applied via R502 to one end of the TRIGGER LEVEL potentiometer R502 and the resulting + signal selected is fed via the + input of the buffer amplifier A501 to impedance convertor V302, which gives a + input to pin 3 of the comparator A502.

When the signal pulse peaks cross the trigger level threshold, the comparator produces output pulses via the grounded base transistor V501.

On comparator output pulses, V502 conducts and the resistor R512 results in a drop in output of 50mV approx. This is done to prevent unwanted oscillation.

When the negative triggering is selected, control relay ReM causes V507 to conduct (logic 1) which means that -10V is applied via R505 to the end of the TRIGGER LEVEL control. Although the +10V is still applied via R504, the smaller value of R505 makes the input negative. Diode V551 also conducts to give a negative polarity signal to invert the comparator output in the digital section.

In the negative trigger mode, V502 is already conducting, so V503 and V504 act as a level shifter to compensate for the difference in levels between logic 0 and logic 1.

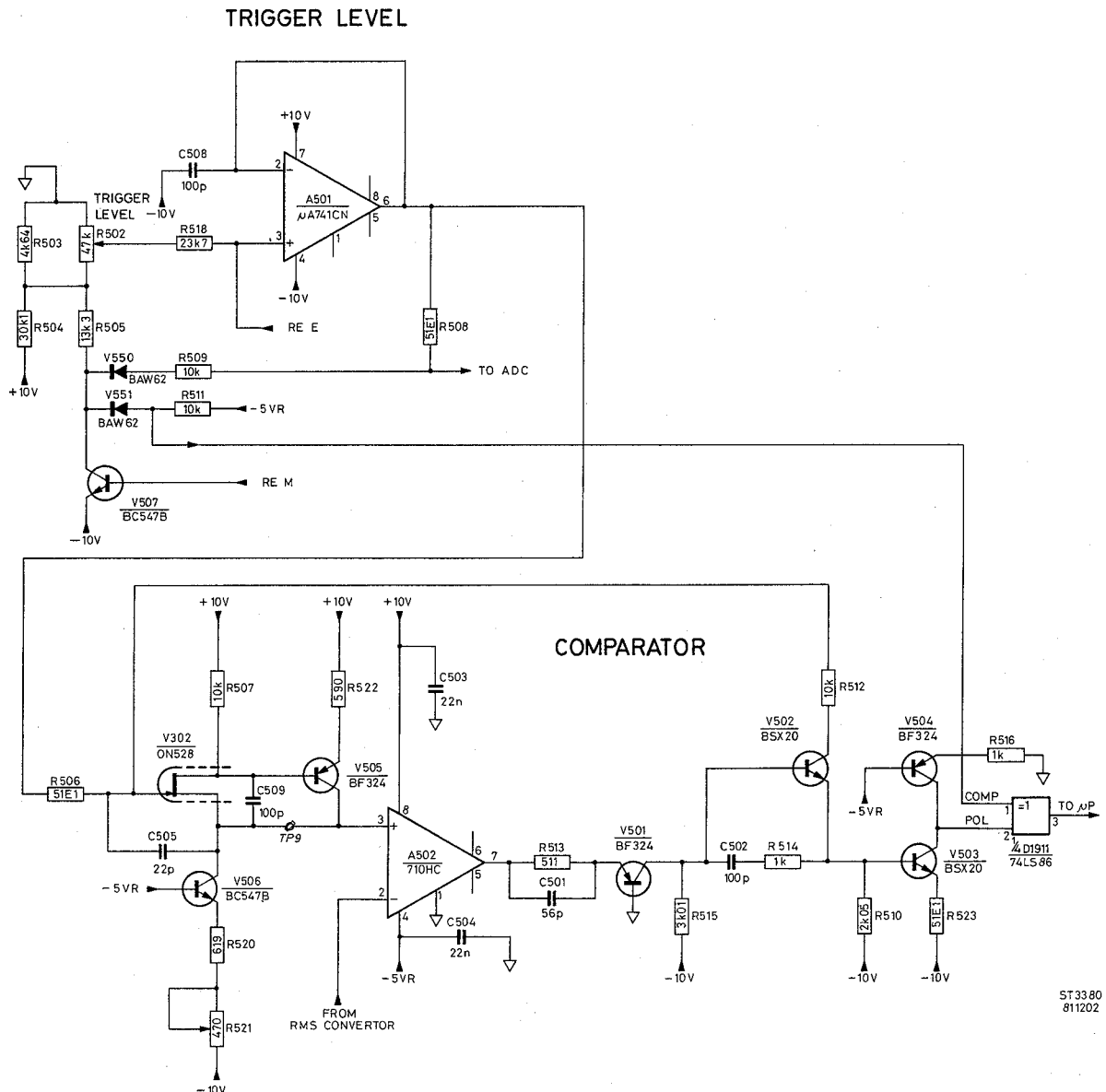

Fig. 28. Frequency measurements

1.4.3.2. *Time measurements (s)*

When the time function is selected, the S1 contact connects the source to the voltage attenuator. After attenuation, it is connected to the + input of the comparator. In the same way, as for frequency measurements the comparator produces output pulses when the signal peaks cross the trigger level selected. These are passed direct to the microprocessor and also to the selection gates of the interrupt controller.

1.4.3.3. *Trigger level measurements*

When trigger level is selected, TL1 function switch contact routes the input signal to the voltage attenuator as for voltage measurements. Contact TL3 connects the attenuated output via the impedance convertor to the + input of the comparator as for frequency measurements. Switch K301 is open in the trigger level function.

1.4.4. Analog section (multifunction measurements)

1.4.4.1. R.M.S. convertor

In the R.M.S. convertor the difference in voltage between the Vin2 and Vin1 is converted into current in a dual V-I convertor.

The current is determined by $\frac{V_{in}}{R}$ and the state of the RNGA signal, (where R is either R305 or R306 + R307). This relay signal from D1908 selects the input sensitivity of the R.M.S. convertor.

The current in the a.c. to d.c. convertor is rectified and then converted into a current again by the R.M.S. section. This current is proportional to the r.m.s. value of the input signal V.

Capacitor C302 is the integrating capacitor for the R.M.S. section. Capacitors C303 and C304 provide the automatic zero (AZ) compensation for the R.M.S. convertor.

The output of the R.M.S. convertor is converted into a voltage by resistor network R309-R312. The output voltage can be adjusted by R310 and is filtered by R314/C306. It is supplied via relay contact K301 to the active filter.

RMS CONVERTOR

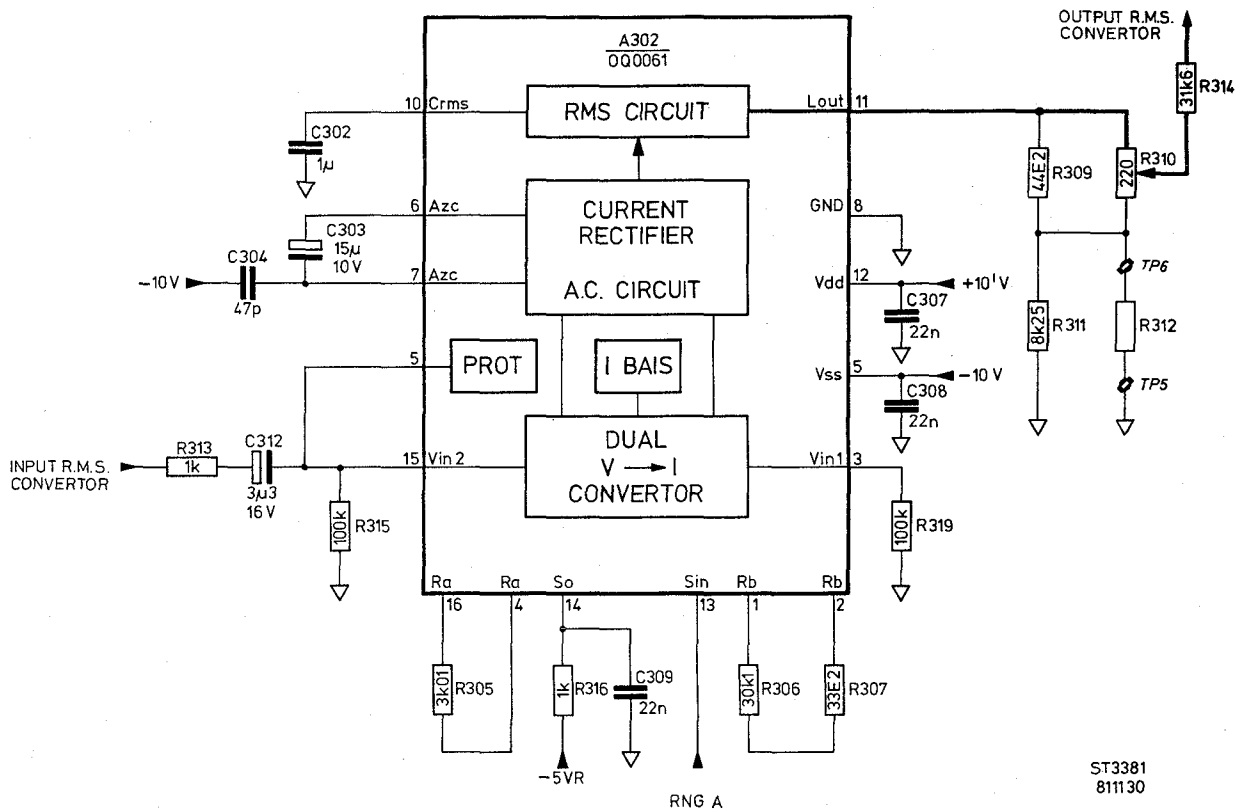

Fig. 29. R.M.S. convertor

ST3381
811130

1.4.4.2. Impedance convertor

The output signal from the a.c. attenuator is passed via switch contact V~ 3 to an impedance convertor which converts the high input impedance signal to a low impedance to match the input of the R.M.S. convertor A302, which would otherwise draw current from the signal.

The gate of FET V302 gives the high impedance input to the stage, which is fed from a current source supplied by V306.

In other measuring functions than a.c., control signal RE P switches on FET switch V301, which short-circuits the a.c. path to earth.

The impedance convertor input is protected against excessive input voltages by:

- Diode-connected V350 which acts as a zener diode for negative voltages
- R304 and the gate-drain junction of V302 for positive voltages.

For the input range from -1V to $+1\text{V}$ on the gate of V302, the output at V305 collector lies between 0V and 2V ; i.e. it is always positive.

IMPEDANCE CONVERTOR (TRIGGER LEVEL RMS/CONV.)

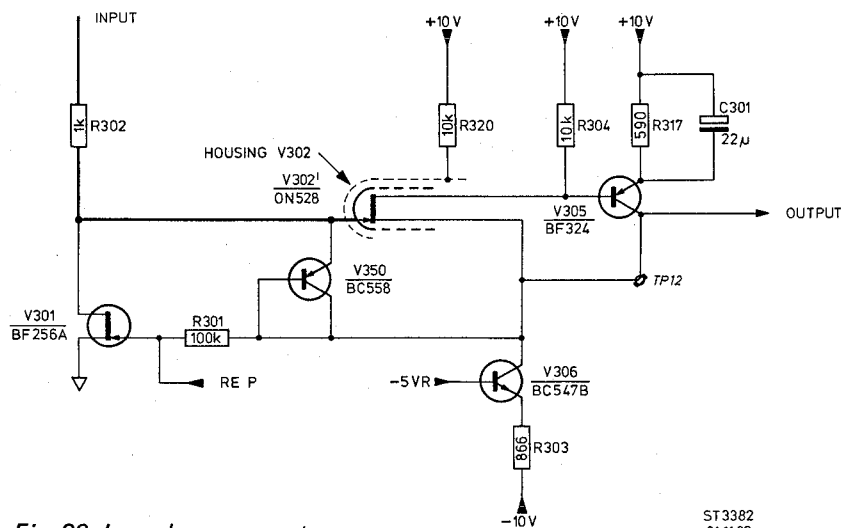

Fig. 30. Impedance convertor

ST3382
81 11 30

1.4.4.3. Active filter

The input to the active filter is via the FET switch V603, activated by a signal from the anode of diode V657 in the relay control D1908 (in all functions except Hz and s).

Filtering is obtained basically by the frequency-dependent feedback network R601, C601 R602, R603, C602, C603 around the operational amplifier A601. The loop coupling to the operational amplifier inputs is achieved via high impedance FET switches V605.

Trimmer R624 provides the offset adjustment.

The output from the active filter is coupled via the FET switches V606, V606', (depending on whether AZ on $\bar{A}Z$ is selected) to the +Vin (FET V608) or the -Vin (FET V608) of the voltage-to-current convertor A602. The output of the operational amplifier A601-6 is also routed via zener diode V654 to a potential divider circuit R609, R610 derived from the +10V supply.

This drops the supply to +8.5V to equalise the conduction points of the V-I convertor FET's caused by the differential inputs.

ACTIVE FILTER

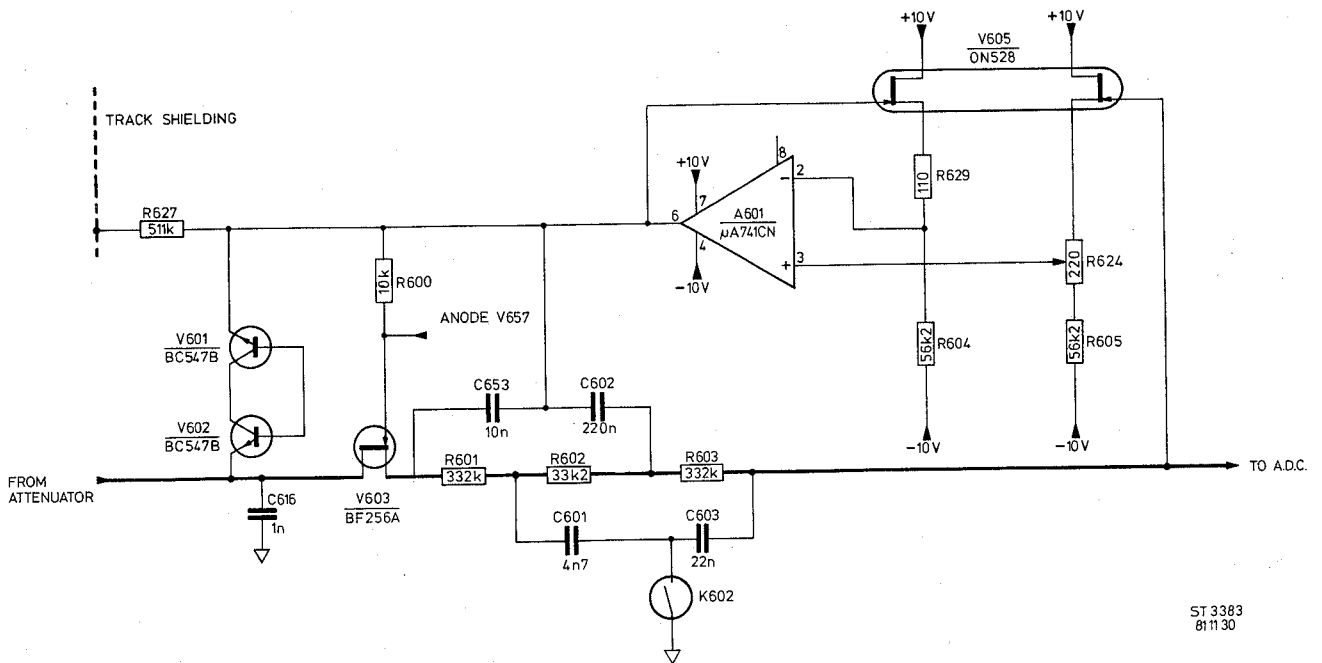

ST 3383
811130

Fig. 31. Active filter

1.4.4.4. Analog-to-digital convertor

The A602 integrated circuit converts the unknown input voltage to a constant current value depending on the magnitude of the input voltage.

Two sensitivities can be selected by the relay control input RNGB, to give either 1V or 0,1V (used in the 200mV measuring range).

The voltage converted to a constant current is the difference between the two inputs of the OQ0064.

The auto zero circuit is designed to compensate for any internal offset which could influence the measuring result of the ADC. This is done by logic signals AZ and \overline{AZ} .

During the first period of a measurement the unknown voltage is supplied via V606' and V608 to the + input (pins 3 and 5) of the OQ0064 while the - input (pins 12 and 10) is connected to zero via V610 and V607, controlled by the \overline{AZ} logic to the gate of V608'.

At the same time, the \overline{AZ} signal via V610 switches the signal path via V606' to V608 and the + input.

In the second period of a measurement the situation is reversed. The AZ logic pulse switches the input signal to the - input, and the + input is now connected to zero via the gate of FET V608 and FET V607'. The source of V607' is normally at 0V except in the temperature measuring function.

In the μp these two signals are subtracted, so any internal offset is compensated.

- AZ = 1 for the first measuring period
- \overline{AZ} = 1 for the second measuring period.

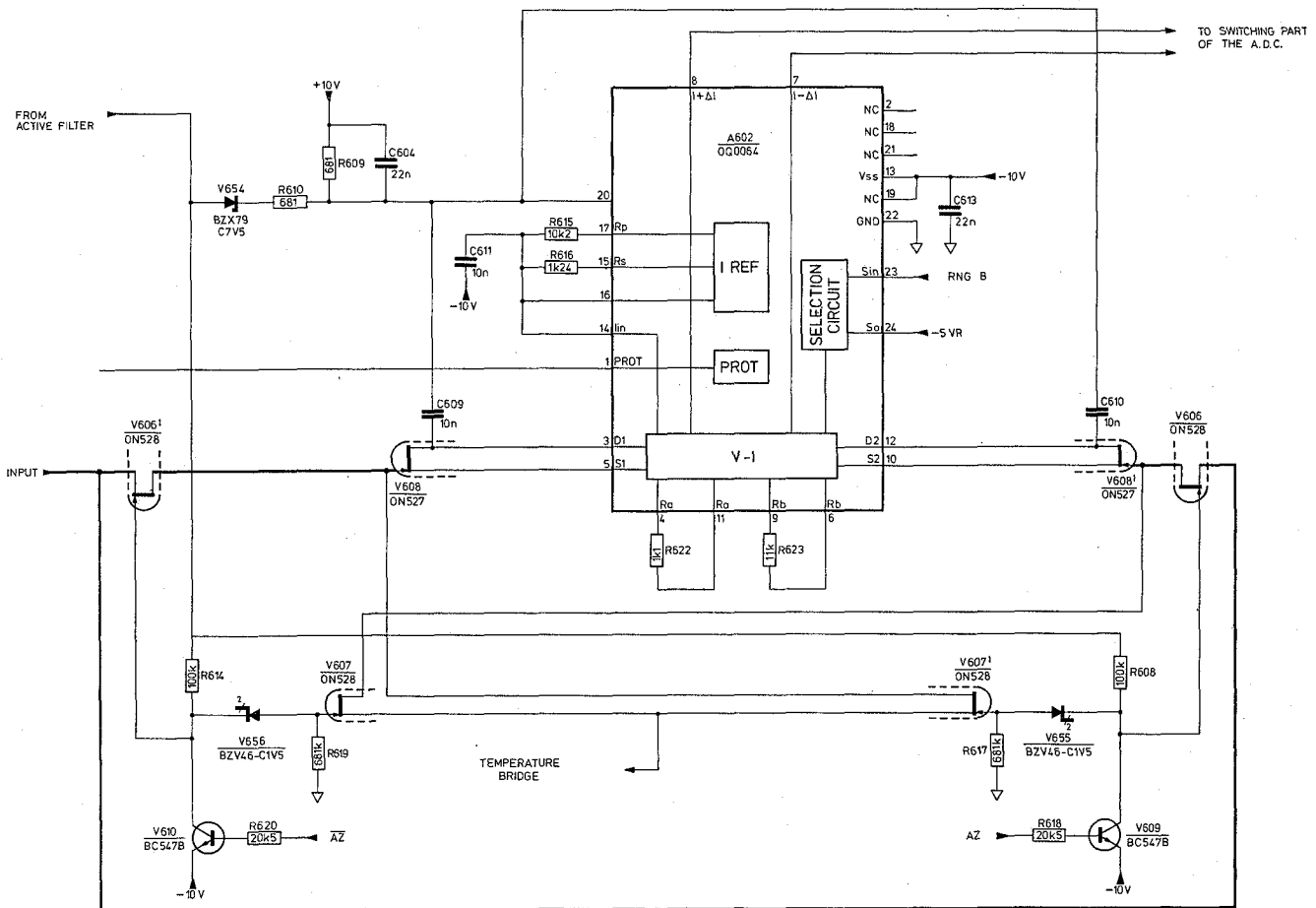

ST3384
81130

Fig. 32. V-I convertor

1.4.5. Control section

1.4.5.1. Interrupt controller

Mode switch interrupts

The four mode switches SK1, SK2, SK3, SK4, when selected, each give a logic 0 pulse via C1919 to input 11 of the 3-input NAND-gate D1918.

Input 12 is held at logic 1 by the pull-up resistor from input 6 (\overline{INT}) of the μP .

When there is no input from the trigger level circuit, input 13 is also at logic 1.

Consequently, a logic 0 pulse from one of the mode switches results in a 0 pulse on the interrupt input \overline{INT} .

During a timing measurement, the S' contact when switched gives a logic 1 to the pin 1 of Schmitt trigger D1917, which gives a logic 0 pulse via C1912 to reset the time measurements.

Trigger level interrupts

Interrupts are also generated by the trigger level circuit in the timer mode, for starting and stopping the μP internal counter during measuring.

The functional circuit is shown in Fig. 33.

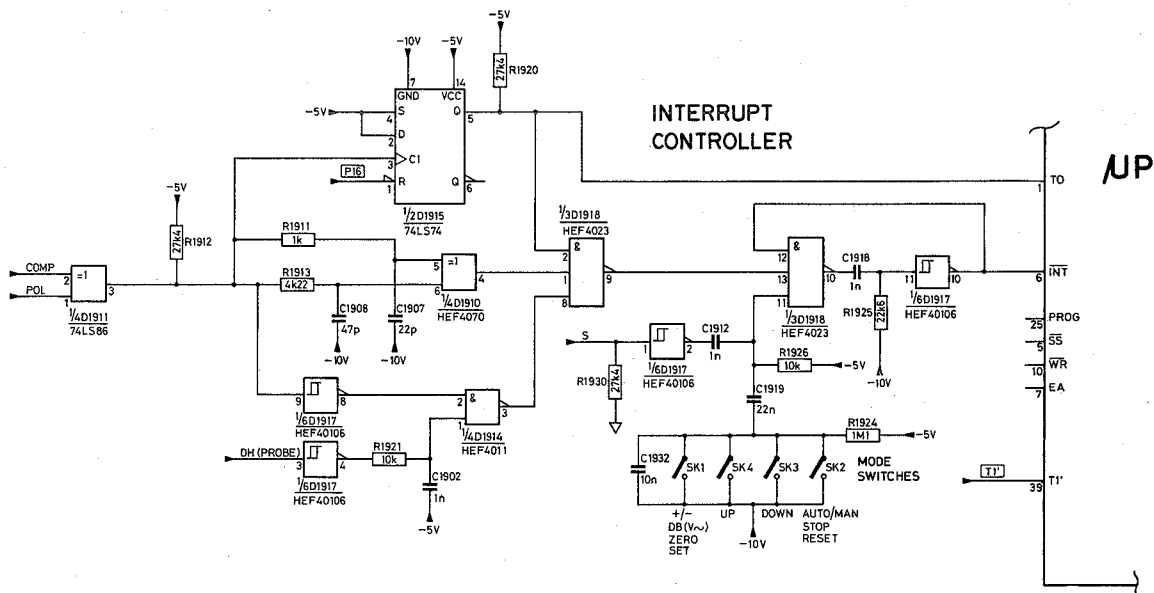

Fig. 33. Interrupt controller

Permanent non-interrupt condition:

Without the timer selected there is no output from the comparator even if Hz is selected because P16 inhibits the flip-flop and gives a '0' on NAND input 2.

Interrupt conditions:

There are two modes of trigger level interrupt:

- The normal trigger-mode, where the signal is triggered on successive positive crossings (or successive negative crossings) of the trigger level.
- The special trigger mode, using the data hold input, where the signal is triggered on successive positive and negative (or negative and positive) crossings of the trigger level.

Considering first, the normal trigger mode; i.e. with the data hold switch open.

As explained, the condition for interrupt is a logic '0' on the $\overline{\text{INT}}$ pin; i.e. all the three inputs of NAND-gate D1918 at logic 1 simultaneously.

Path 1 takes the comparator output waveform to the NAND-gate input 2 of D1911 via a two-input exclusive-OR gate.

A logic '1' is passed only when a '1' input appears on either one or the other of the inputs.

Two small RC delays are applied to the inputs so that the inputs arrive at slightly different times after the start of the comparator output waveform. This means that for a short period, i.e. the difference in the delay times, one of the inputs, the one with the shorter delay is at logic '1'. Consequently, a logic '1' appears at the output of the gate for this short period until the other input is at logic '1'; i.e. the condition for '0' output.

At the end of the comparator pulse, the input with the shorter delay returns to logic '0' after its delay time. However, the other input remains at logic '0' for its delay period and gives a corresponding logic '1' pulse to the gate output as shown.

Path 2 inverts the comparator output waveform and applies it via a NAND-gate to input 8 of D1918 in its original form.

Path 3 applies the comparator output via the clock input of the flip-flop to the output, which is applied to the third input 2 of the NAND-gate.

All three inputs of NAND-gate D1918 are at logic '1' during the positive-going crossings of the trigger-level.

As path 2 changes polarity at the end of the positive-going comparator pulse, no intermediate interrupt pulse occurs in the normal trigger mode.

Considering the special trigger mode the circuit functions are identical, except that the data hold input puts a logic '0' on to the input of the NAND-gate in path 2. This means that the output, and consequently input 8 of NAND-gate D1918, are permanently at logic '1'.

The intermediate pulse from the exclusive-OR gate now forces the output of NAND-gate D1918 to logic '0' for its duration.

The outcome is that the μP counter is stopped at the negative crossing of the trigger level in the special trigger mode. The foregoing explanation has assumed that positive trigger has been selected. When negative trigger is selected, the start point is a negative-crossing of the trigger level and the stop point, a positive crossing of the trigger level.

Counter output control

The counter consists of two high-speed 4-bit binary counters in cascade giving an 8-bit output via buffers to the databus. Low to high transitions of the input (2) result in synchronous changes of the outputs to the buffers.

The master reset input \overline{MR} when at logic '0' resets all outputs regardless of inputs.

The hold \overline{HLD} pulse is a logic '0' from the μP ; logic '1' enables counting operations.

The 8-bit output is routed to an integrated circuit D1901 containing eight 3-state buffers.

The outputs from the counter are directly routed to the databus by logic '0' on the \overline{ECO} (\overline{OE}) input. This condition requires a \overline{RD} pulse ('0') and a P17 and A7 signal applied together.

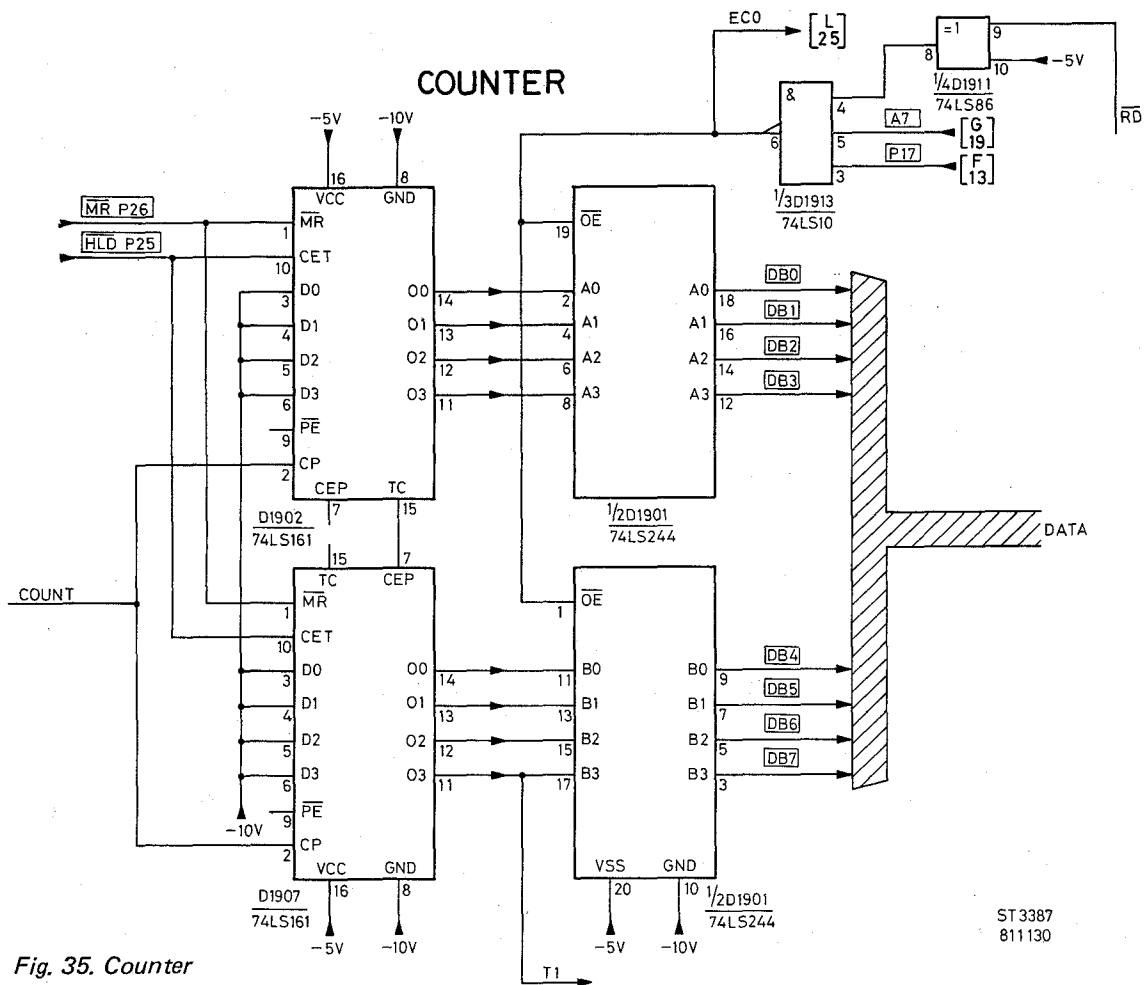

Fig. 35. Counter

1.4.5.3. Analog control

Control inputs

The ten function switches when selected, provide a -10V supply to one of ten independent inputs of D1916, D1918. These integrated circuits are two 8-channel analog multiplexers, scanned by three address inputs P20', P21', P22' and a chip select pulse P23'.

Internally, the analog switches have one side connected to a common output line (pin 3) that is connected via a diode V901 to P24 of the μP (logic '0' output).

The mode switches are also connected to four of the independent inputs of D1919.

The multiplexers act as switch decoders. At the start of a measuring program, the address lines scan the two 1-of-8 decoders under software control and detect the function and any mode conditions.

The control address signals are derived from the μP part 2 outputs P20, P21, P22, P23, clocked via the bistable flip-flop circuit D1912.

When trigger level is selected, the -10V on pin 4 of D1916 is applied to the NAND-gate D1918, input 3 to give a logic '1' at the data input (12) of the GATE control flip-flop D1915.

SWITCH DECODING

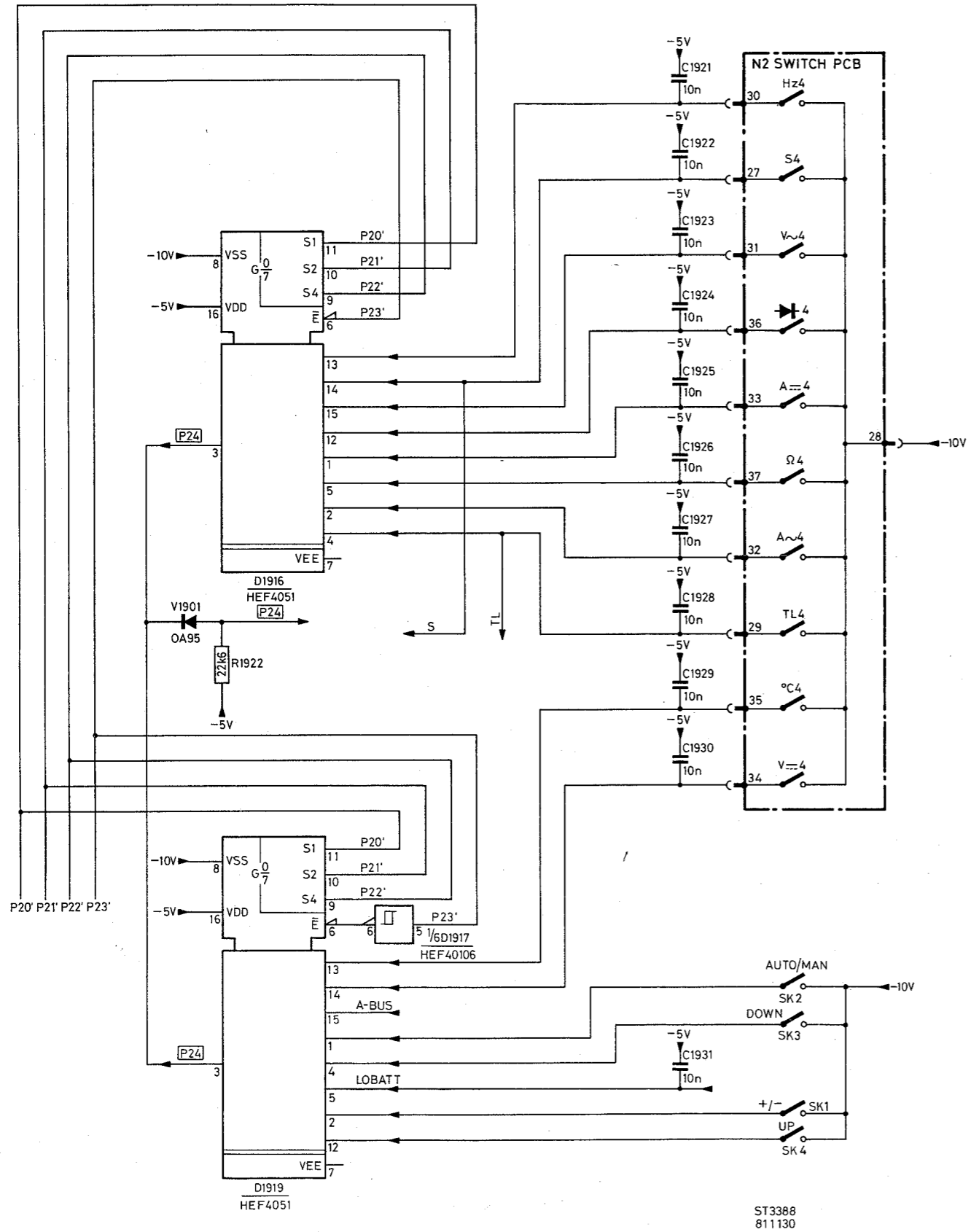

Fig. 36. Switch decoding

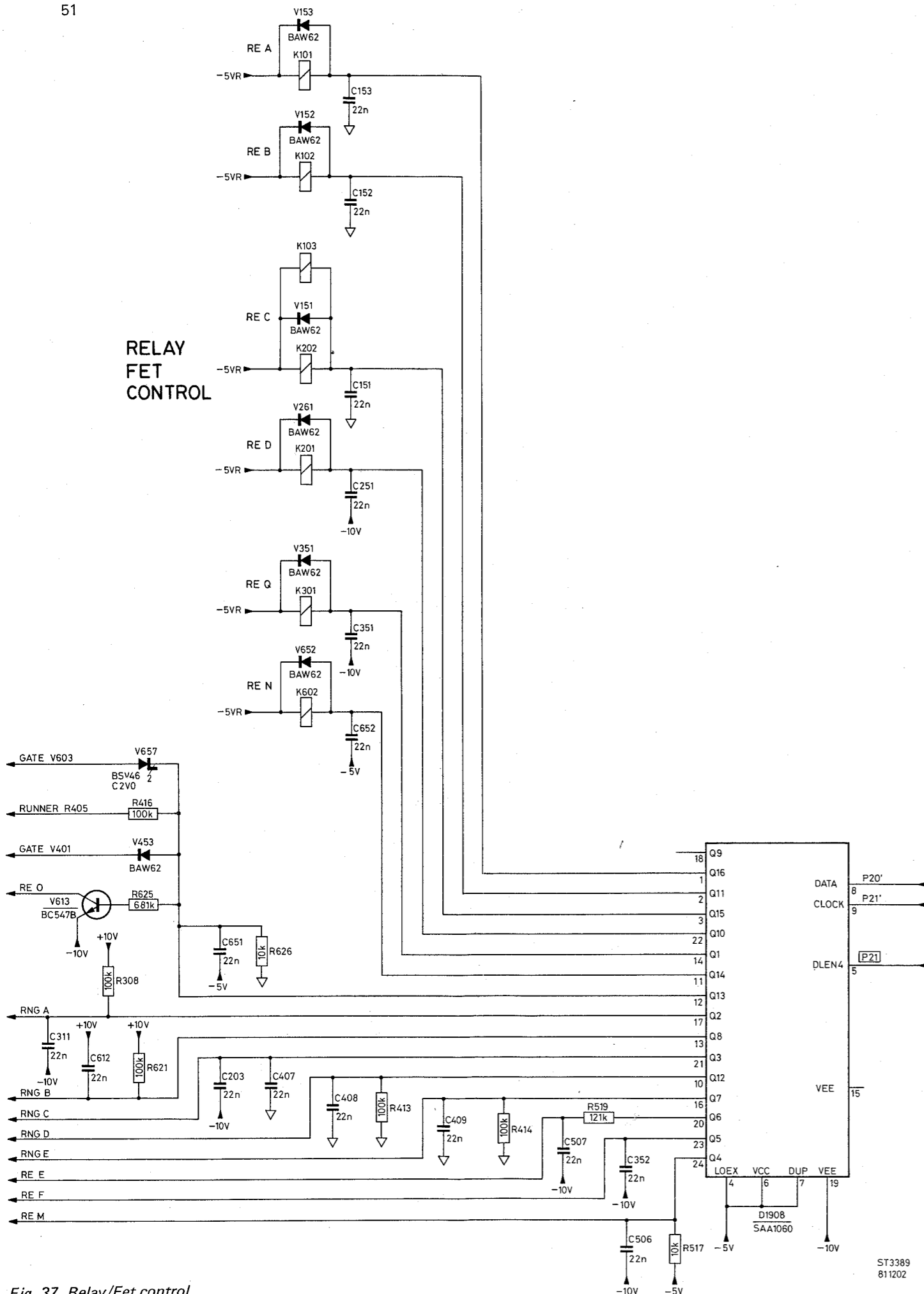

Fig. 37. Relay/Fet control

Control outputs



Control of the reed relays used for range changing, function switching, etc. is achieved by the RELAY FET CONTROL interface circuit D1908 (SAA1060). The circuit is software controlled from the μP by the DATA signal P20', the CLOCK input P21' and the enable signal P11 (DLEN4).

In the bus control circuit of D1908, the data is checked for word length (17 bits + leading zero) to establish whether it is valid data and not interference. The serial data is fed to a 17-bit shift register where it is loaded into a 16-bit latch B (there are two latches, A is not used in this application). From here it is switched directly in parallel form to the appropriate outputs for relay control. See Fig. 37.

OUTPUTS SAA1060

BIT NO	B7	B6	B5	B4	B3	B2	B1	B0	B7	B6	B5	B4	B3	B2	B1	B0
PIN NO	1	3	11	12	10	2	22	18	13	16	20	23	24	21	17	14
SIGNALS	REA	REC	REN	RED	RNGD	REB	RED		RNGB	RNGE	REE	REP	REM	RNGC	RNGA	REQ
RANGE																
200mV ∴	1	1	0	1	0	1	0	1	0	0	0	1	0	0	1	1
2 V ∴	1	1	0	1	0	1	0	1	1	0	0	1	0	0	1	1
20 V ∴	0	1	0	1	0	1	0	1	1	0	0	1	0	0	1	1
200 V ∴	1	1	0	1	0	0	0	1	1	0	0	1	0	0	1	1
2000 V ∴	1	0	0	1	0	1	1	1	1	0	0	1	0	0	1	1
200mV ~	1	1	0	1	0	1	0	1	1	0	0	0	0	0	0	0
2 V ~	1	1	0	1	0	1	0	1	1	0	0	0	0	0	1	0
20 V ~	0	1	0	1	0	1	0	1	1	0	0	0	0	0	1	0
200 V ~	1	1	0	1	0	0	0	1	1	0	0	0	0	0	1	0
2000 V ~	1	0	0	1	0	1	1	1	1	0	0	0	0	0	1	0
200 Ω	1	1	1	1	0	1	0	1	0	1	0	1	0	0	1	1
2KΩ	1	1	1	1	0	1	0	1	1	1	0	1	0	0	1	1
20KΩ	1	1	1	1	0	1	0	1	1	0	0	1	0	1	1	1
200KΩ	1	1	1	1	0	1	0	1	1	0	0	1	0	1	1	1
2MΩ	1	1	1	0	1	1	0	1	1	0	0	1	0	0	1	1
20MΩ	1	1	1	0	1	1	0	1	1	0	0	1	0	1	1	1
2 μA ∴	1	1	0	1	0	0	1	0	1	0	0	1	0	0	1	1
20 μA ∴	1	0	0	1	0	1	1	1	0	0	0	1	0	0	1	1
200 μA ∴	1	0	0	1	0	1	1	1	1	0	0	1	0	0	1	1
2mA ∴	1	1	0	1	0	0	0	1	0	0	0	1	0	0	1	1
20mA ∴	1	1	0	1	0	0	0	1	1	0	0	1	0	0	1	1
200mA ∴	1	1	0	1	0	0	1	0	0	0	0	1	0	0	1	1
2 A ∴	1	1	0	1	0	0	1	0	1	0	0	1	0	0	1	1
20 A ∴	1	0	0	1	0	1	1	1	1	0	0	0	0	0	1	1
2 μA ~	1	1	0	1	0	0	1	0	1	0	0	0	0	0	1	0
20 μA ~	1	0	0	1	0	1	1	1	1	0	0	0	0	0	0	0
200 μA ~	1	0	0	1	0	1	1	1	1	0	0	0	0	0	1	0
2mA ~	1	1	0	1	0	0	0	1	1	0	0	0	0	0	0	0
20mA ~	1	1	0	1	0	0	0	1	1	0	0	0	0	0	1	0
200mA ~	1	1	0	1	0	0	1	0	1	0	0	0	0	0	0	0
2 A ~	1	1	0	1	0	0	1	0	1	0	0	0	0	0	1	0
20 A ~	1	0	0	1	0	1	1	1	1	0	0	0	0	0	0	0

BIT NO	B7	B6	B5	B4	B3	B2	B1	B0	B7	B6	B5	B4	B3	B2	B1	B0
PIN NO	1	3	11	12	10	2	22	18	13	16	20	23	24	21	17	14
SIGNALS	REA	REC	REN	RED	RNGD	REB	RED		RNGB	RNGE	REE	REP	REM	RNGC	RNGA	REQ
2 VTL	1	1	0	1	0	1	0	1	1	0	1	0	0	0	1	0
20 VTL	0	1	0	1	0	1	0	1	1	0	1	0	0	0	1	0
200 VTL	1	1	0	1	0	0	0	1	1	0	1	0	0	0	1	0
2000 VTL	1	0	0	1	0	1	1	1	1	0	1	0	0	0	1	0
2 V s	1	1	0	0	0	1	0	1	1	0	1	0	0	0	1	0
20 V s	0	1	0	0	0	1	0	1	1	0	1	0	0	0	1	0
200 V s	1	1	0	0	0	0	0	1	1	0	1	0	0	0	1	0
2000 V s	1	0	0	0	0	1	1	1	1	0	1	0	0	0	1	0
2 VHz	1	1	0	0	0	1	0	1	1	0	1	0	0	0	1	0
20 VHz	0	1	0	0	0	1	0	1	1	0	1	0	0	0	1	0
200 VHz	1	1	0	0	0	0	0	1	1	0	1	0	0	0	1	0
2000 VHz	1	0	0	0	0	1	1	1	1	0	1	0	0	0	1	0
°C	1	0	0	1	0	1	0	1	0	1	0	1	0	0	1	1
→	1	1	0	1	0	1	0	1	1	1	0	1	0	0	1	1
Calibration measurements																
AUTOCAL 0,1V	-	-	1	0	0	-	-	-	0	0	-	-	-	0	-	-
AUTOCAL 1V	-	-	1	0	0	-	-	-	1	1	-	-	-	0	-	-
I ZERO 200mA	1	1	1	1	0	1	1	0	0	0	1	-	-	1	1	1
I ZERO 2A	1	1	1	1	0	1	1	0	1	0	1	-	-	1	1	1

NOTE: 0 = high imp. relay or FET is in ()
1 = low imp. relay or FET is out ()
- = no change

1.4.5.4. ROM circuits and address/data decoding

The program memory stores for the μP use two 2K 8-bit UV erasable PROM (programmable read-only) memories with fast single address location programming. These are addressed by two 6-bit latches from the μP .

Address/data decoding

The instrument addressing is achieved by the 8 lines of the data bus DB0 to DB7 and four high-order program lines from part 2 of the μP ; P20, P21, P22, P23. These lines are presented to two flip-flop latches D1905 and D1906.

These are D-type flip-flops, each with six data inputs, a clock input (CP), a master reset input \overline{MR} and six buffered outputs.

The ROM/address outputs are transferred on logic '1' pulses of the clock if \overline{MR} is at logic '1' (permanently held at 1).

When at logic '0', \overline{MR} resets all the flip-flops independently of the CP state and the data inputs.

The addresses are clocked by the negative-going edge of the ALE pulse from the μP , via an exclusive OR gate D1911.

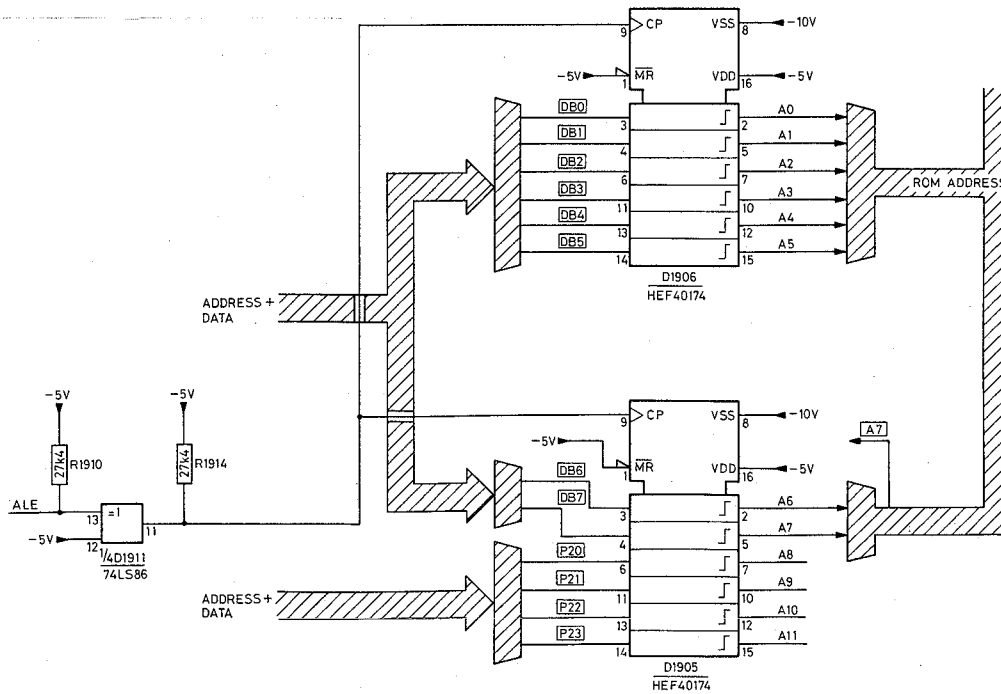

ST3390
81 1130

Fig. 38. Address decoding

ROMs

The two ROMs are each addressed by the eight address lines A0 to A7 and three of the program control lines P20, P21, P22.

When addressed, the ROM responds by sending the instruction or data in the location addressed on the eight lines of the databus.

This data output function is controlled by the PSEN (program store enable) signal (pin 9) sent by the μ P. This is applied to NAND-gate D1921, wired as an inverter and gives a logic "1" on NAND-gate inputs D1921-12 and D1921-5.

Signal P23 is a chip select input via inverter D1921, which is used to select either D1909 or D1920 via input pin 20.

MEMORY

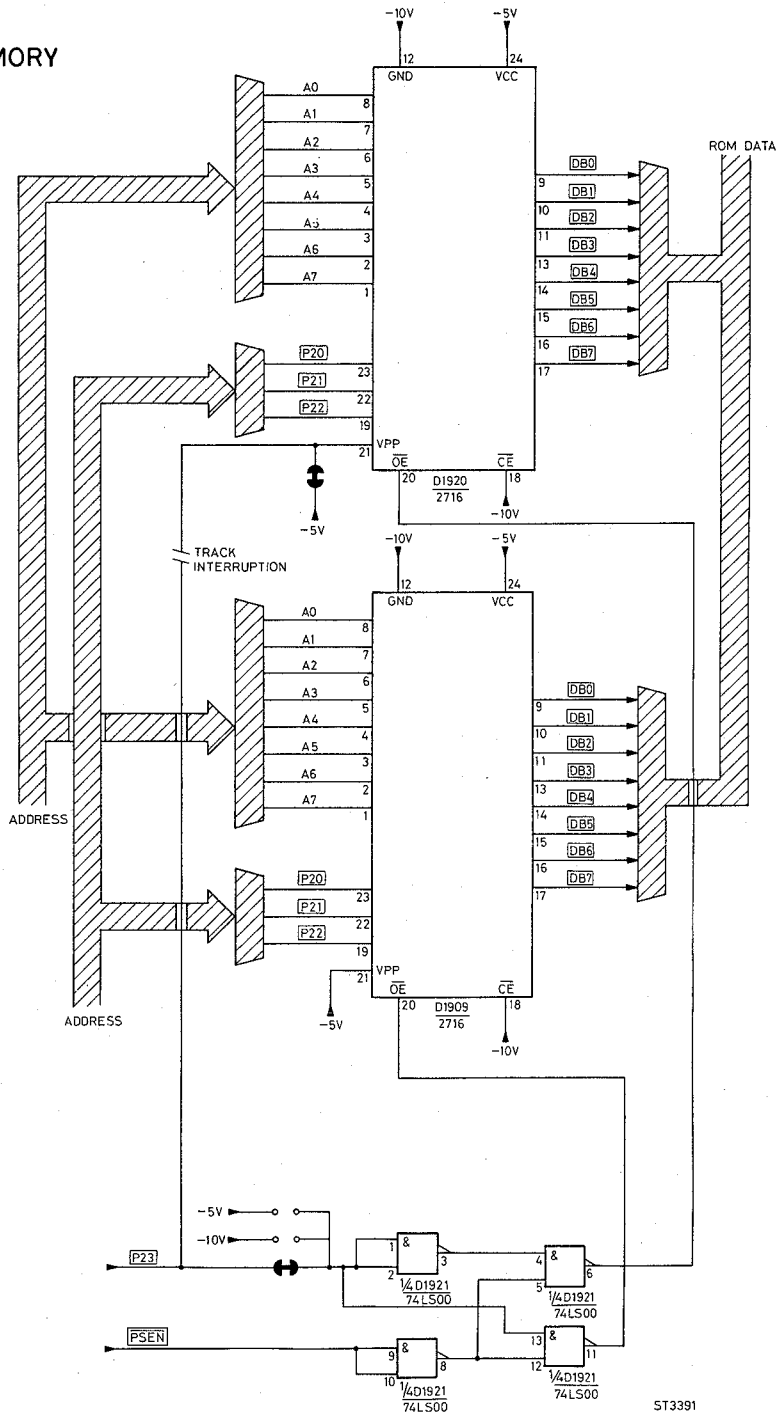

ST3391
811130

Fig. 39. Memory

1.4.6. Display section

The display section of the PM2521 contains three L.C.D. interface circuits.

Each chip is driven by the common serial data input signal and synchronised clock signal, but is separately enabled.

Internally, a bus control circuit verifies and accepts these inputs, decodes them and sets the data in a shift register. After acceptance, the data is latched and the 20 bits are transferred to the display segment outputs. The 58 segments that comprise the total display capability are distributed between the three interface chips.

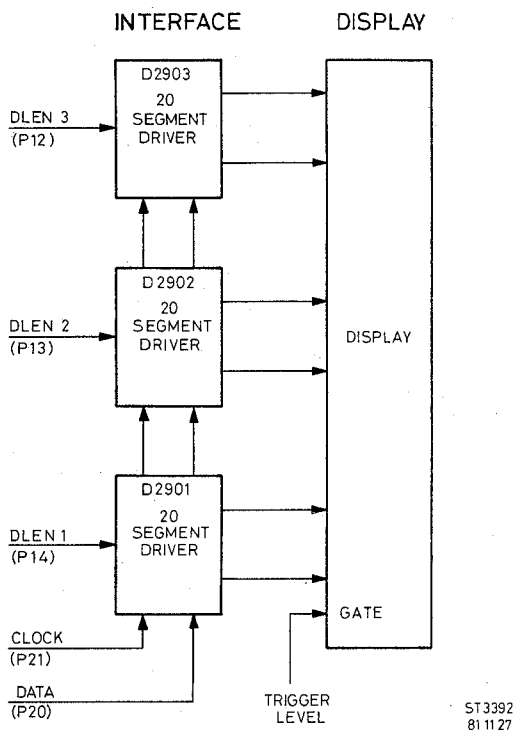

Fig. 40. Display interface

1.4.7. Power supply

The power supply unit consists of a transformer, rectifiers and a stabilizing section for the rectified voltages. The voltages used are:

- | | | |
|----|--------|-----------------------------------------|
| 1. | - 5V | logic 1 |
| 2. | - 10V | logic 0 |
| 3. | - 5VR | special relay voltage |
| 4. | + 10V | } stabilized voltages |
| 5. | + 10'V | |
| 6. | + VR | } non-stabilized voltages +12V and -12V |
| 7. | - VR | |

The +10V, +10'V is made with a +5V regulator A801 and a zener diode V855 in series.

NOTE: It is also possible that a +10V regulator may be used and instead of the zener diode V855 is then replaced by a wire link.

By means of an operational amplifier A802 the +10V is converted into -10V.

The -5V is made with the stabilization circuit V801, V802 and V852. Because of the high current which flows to the components a Darlington transistor V803 is used. Unwanted oscillation is prevented by C809 and L801.

2. ACCESS

WARNING: The opening of covers or removal of parts, except those to which access can be gained by hand is likely to expose live parts, and accessible terminals may also be live.

The instrument shall be disconnected from all voltage sources before any replacement or maintenance and repair during which the instrument will be opened.

If afterwards, any adjustment, maintenance or repair of the opened instrument under voltage conditions is inevitable, it shall be carried out only by a skilled person who is aware of the hazard involved.

Bear in mind that capacitors inside the instrument may still be charged even if the instrument is separated from all voltage sources.

2.1. DISMANTLING THE PM2521

2.1.1. Removing the top cover. (fig. 41)

- Place the handle in its bottom position.
- Remove the two fixing screws at the rear which attach the top cover to the bottom cover.
- Lever the top cover and pull it backwards.
- Disconnect the transformer plug which is connected to X802.

2.1.2. Removing the bottom cover. (fig. 42)

- Remove the top cover.
- Remove the handle.
- Remove the two fixing screws which attach the printed-circuit board to the bottom cover. (fig. 42 item 1).
- Bend out the two hooks of the front plate. (fig. 42 item 2).
- Remove the bottom cover.

2.1.3. Removing the front assembly

- Remove top and bottom cover.
- Disconnect the flexible print from the connector X1901. (fig. 42 item 3).
- Bend out the two hooks of the front plate at the bottom of the printed-circuit board. (fig. 43 item 1).
- Disconnect the front from the printed-circuit board.

NOTE: The potentiometer R502 is still connected with the printed circuit board.

2.2. REPLACING PARTS

2.2.1. Liquid crystal display (fig. 44 item 1), display unit N3 (fig. 44 item 2), interconnection rubber (fig. 44 item 3) or function knob (fig. 44 item 4).

- Remove the front assembly.
- Remove the six screws and the screening plate of the front assembly. (fig. 44 item 6).

NOTE: The potentiometer R502 can now be removed.

- Remove the function knob by bending out the four hooks of the front plate. (only for replacing the function knob) (fig. 44 item 8).
- Remove the three screws from the display unit cover and the cover itself. (fig. 44 item 5).
- Replace the defective component and mount the L.C.D. unit again as described above.

NOTE 1: Make sure that the L.C.D., the display unit cover and the interconnection rubber are placed in the most right hand position. (fig. 44 item 7).

NOTE 2: Do not touch the contacts of the L.C.D., the interconnection rubber and the display unit N3 with the fingers.

2.2.2. Function switch. (fig. 42)

- Remove the top- and bottom cover. Remove also the front assembly.
- Bend out the two hooks and remove the printed-circuit board. (fig. 42 item 4).
- The function switch consist of:
 - 2 slide bodies
 - 4 springs
 - 4 switch contacts
- Remove the screws and nuts from the slide bodies. The bodies can now be lifted from the printed-circuit board.

NOTE: The slide body is stocked complete with springs and switch contacts.

2.2.3. Thermal fuse

- Remove the bottom cover.
- Remove the four screws which attach the screening plate of the transformer to the bottom cover. (fig. 45 item 1).
- Unsolder the black wire connecting the transformer with the screening. (fig. 45 item 2).
- Unsolder the connections of the thermal fuse. (fig. 45a. item 1).
- Replace the thermal fuse as shown in fig. 45a.

NOTE: Do not replace the thermal fuse with a piece of wire as this gives the danger of a fire hazard.

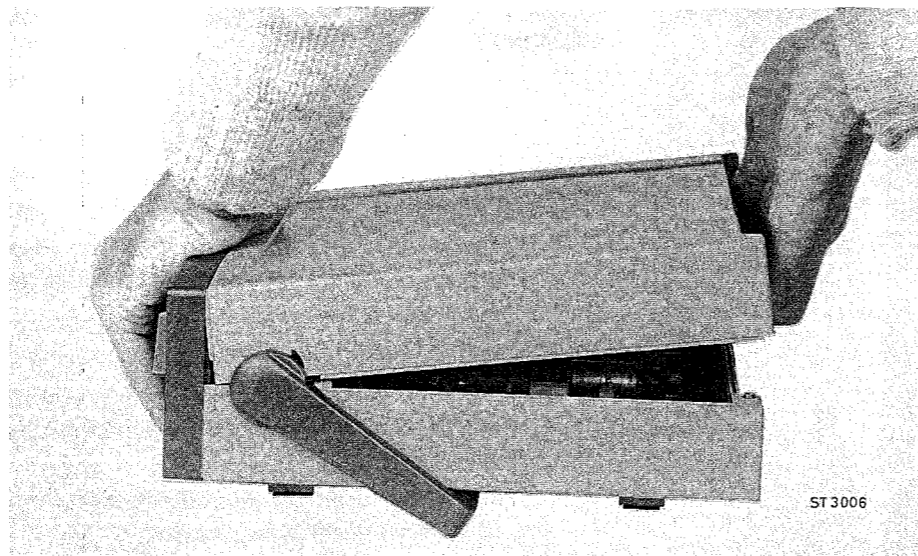

Fig. 41. Removing the top cover

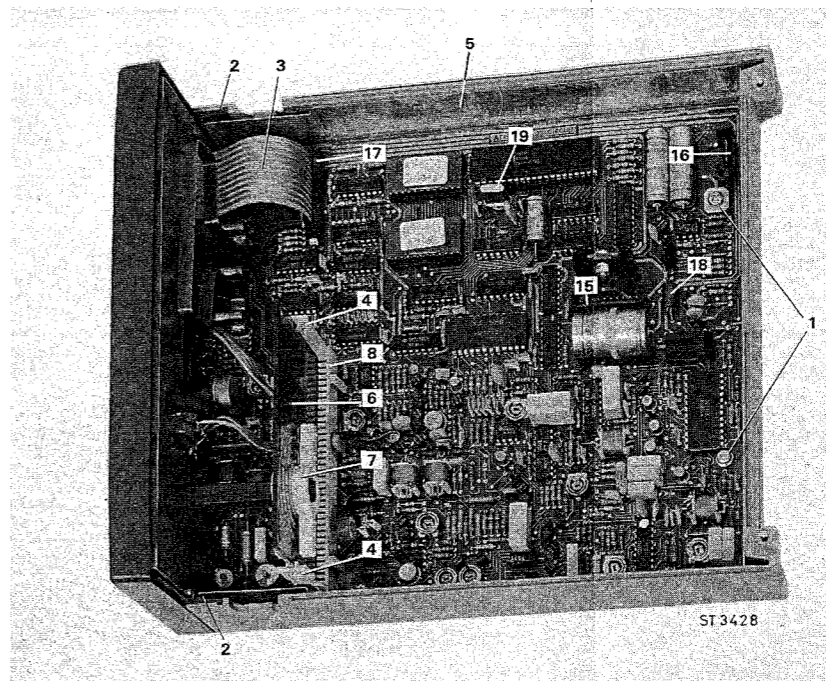

Fig. 42. Removing the bottom cover and front

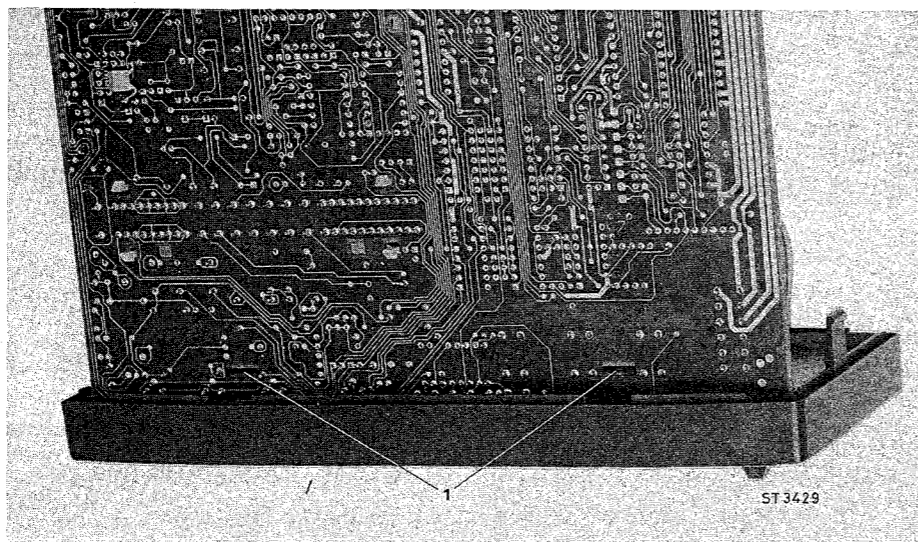

Fig. 43. Removing the front

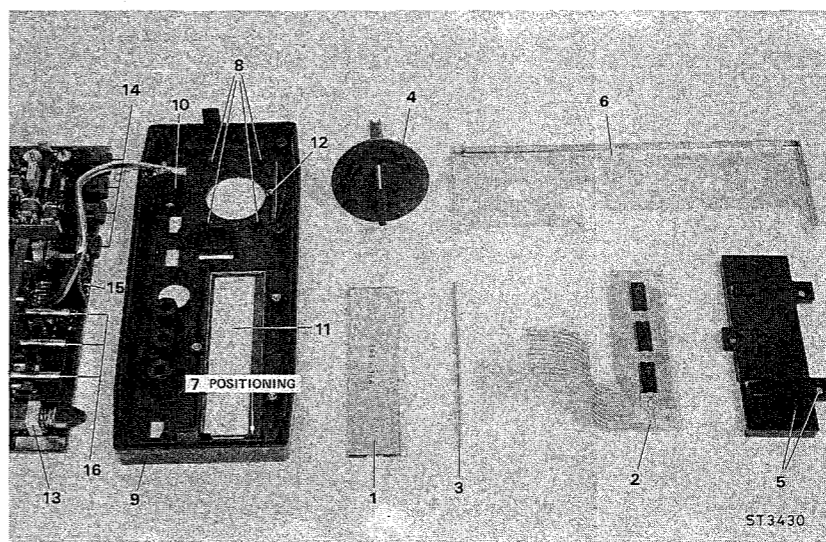

Fig. 44. Front assembly

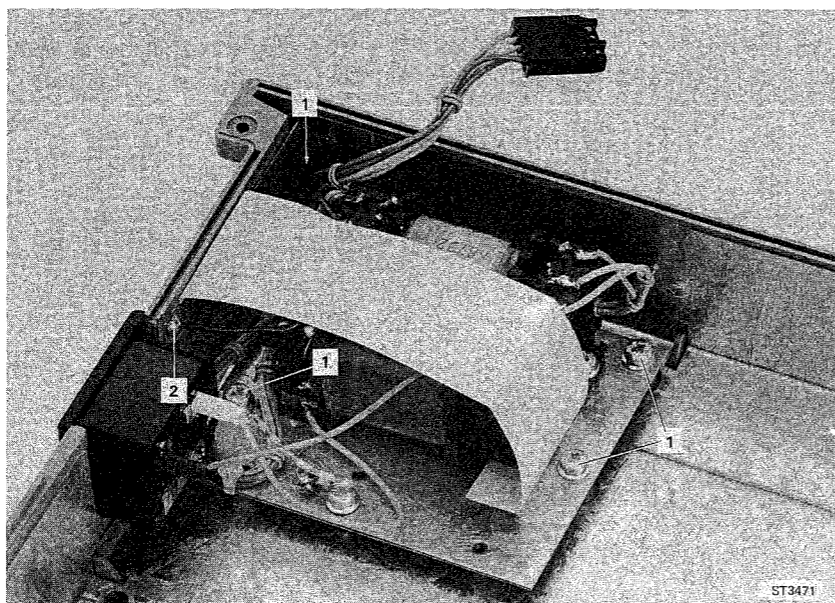

Fig. 45. Removing the thermal fuse

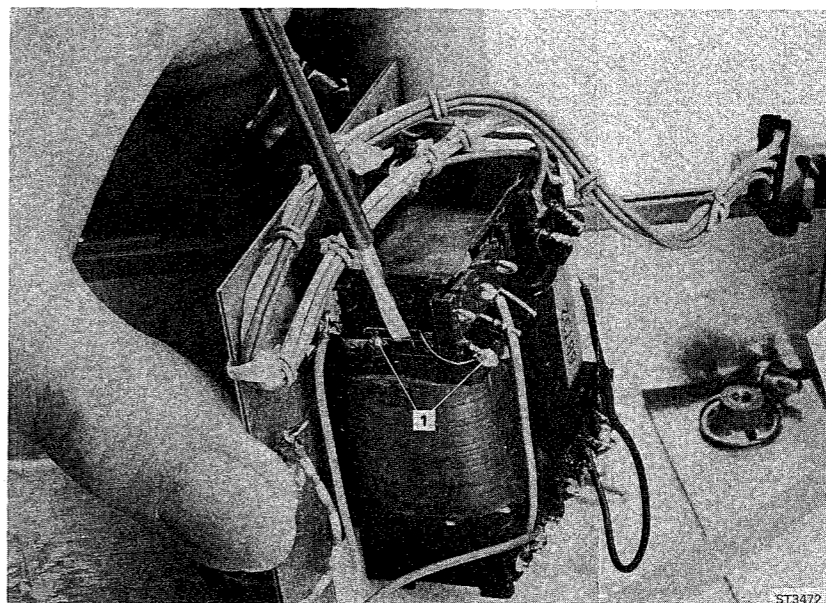

Fig. 45a. Removing the thermal fuse

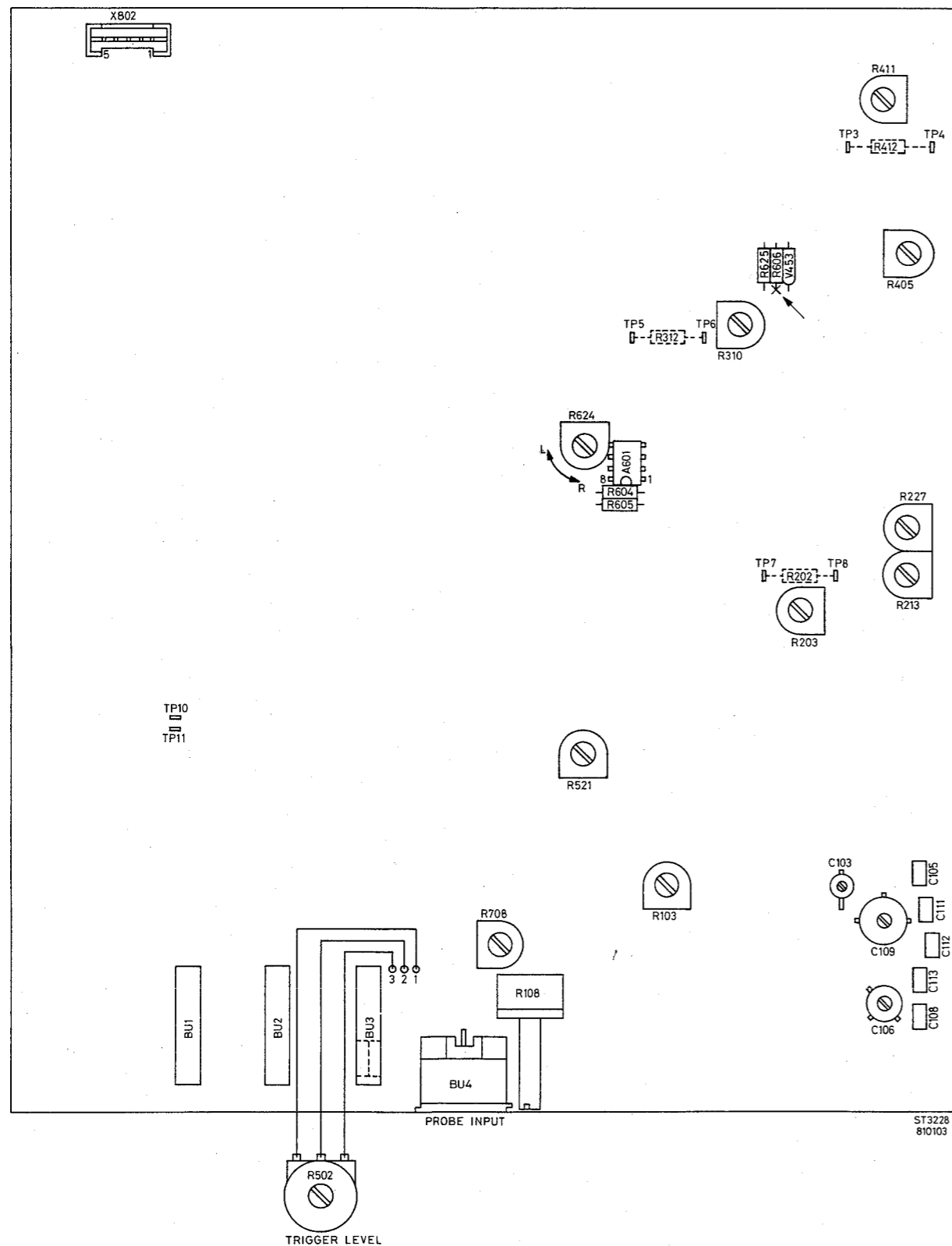

Fig. 46. Adjusting elements

3. CHECKING AND ADJUSTING

WARNING: Before switching-on, ensure that the instrument has been installed in accordance with the instructions outlined in Section 5 of the Operating Manual.

The opening of covers or removal of parts, except those to which access can be gained by hand is likely to expose live parts, and accessible terminals may also be live.

The instrument shall be disconnected from all voltage sources before any replacement or maintenance and repair during which the instrument will be opened.

If afterwards, any adjustment, maintenance or repair of the opened instrument under voltage conditions is inevitable, it shall be carried out only by a skilled person who is aware of the hazard involved.

Bear in mind that capacitors inside the instrument may still be charged even if the instrument is separated from all voltage sources.

The tolerances in this chapter correspond to the factory data, which only apply to a completely re-adjusted instrument. These tolerances may deviate from those mentioned in the Technical Data. (Chapter 2. of the Operating Manual).

For a complete re-adjustment of the instrument the sequence in this chapter should be adhered too. When individual components, especially semi-conductors are replaced, the relevant section should be completely re-adjusted.

To calibrate this measuring instrument only reference voltages and measuring equipment with the required accuracy should be applied. If such equipment is not available, comparative measurements can be made with another calibrated PM2521. However, theoretically in extreme cases, the tolerances may leave some room for doubt.

The measuring arrangement should be such that the measurement cannot be affected by external influences. Protect the circuit against temperature variations (fans, sun).

With all the measurement the cables should be kept as short as possible; at higher frequencies co-axial leads should be used.

Non screened measuring cables may act as serials so that the measuring instrument will measure LF voltage values or hum. voltage.

Before checking and adjusting, remove the top-cover. Make sure that the cable from the power supply is connected with X802.

In the software there are two subroutines which are used for adjusting the PM2521. To call these subroutines short circuit TP10 and TP11 for one second (first subroutine) and repeat it for the next subroutine. After using these subroutines the PM2521 should be reset. (Switch the PM2521 off and on).

3.1. DC RANGES

No.	Adjustment	Adjusting element	Preparations	Input signals	Adjusting data	Measuring points
1.	DC ranges Active filter	Potentiometer R624	Set instrument in position V ... Select: MAN ranging : 1000V range	Short circuit the $V \Omega$ mA and the 0 socket	$0mV \pm 1mV$ measured with a DC meter $\pm 0,5\%$	A601 point 6 and 0 socket
2.	Zero setting	Potentiometer R108	Set instrument in position V ... Select: MAN ranging : 200mV range	Short circuit the $V \Omega$ mA and the 0 socket	$\pm 000.00mV \pm 1$ dig.	Display
3.	Reference current for the ADC	Resistor R412; coarse (MR25, 1% E96 series)	Set instrument in position V ... Select: first subroutine (Short circuit TP10 and TP11 for one second; k is displayed; * is blinking)		-1V or as close as possible to the -1V measured with a DC meter $\pm 0,5\%$	R606 (front panel side) and the 0 socket
4.	CAL mode	Potentiometer R411	Set instrument in position V ... Select: second subroutine (Short circuit TP10 and TP11 for one second; Z is displayed; * is blinking)	$+20V \pm 0,005\%$ supplied to $V \Omega$ mA and 0 socket	$+20.000 \pm 1$ dig	Display
5.	Check		Switch the instrument off and on Set instrument in position V ... Select: MAN ranging : 20V range	$+20V \pm 0,005\%$ supplied to $V \Omega$ mA and 0 socket	$+20.000V \pm 2$ dig	Display

No.	Adjustment	Adjusting element	Preparations	Input signals	Adjusting data	Measuring points
6.	2V range	Potentiometer R103	Set instrument in position V ∴ Select: MAN ranging : 2V range	+2V ± 0,005% supplied to V Ω mA and 0 socket	+2.0000V ± 1 dig	Display
7.	Check		Set instrument in position V ∴ Select: MAN ranging : 20V range	+20V ± 0,005% supplied to V Ω mA and 0 socket	+20.000V ± 6 dig	Display
<i>NOTE: If the tolerance is > 6 dig then repeat adjustment 3, 4, 5 and 6.</i>						
8.	Check		Set instrument in position V ∴ Select: MAN ranging : 200mV range	a. +200mV ± 0,005% b. -200mV ± 0,005% c. +100mV ± 0,005% supplied to V Ω mA and 0 socket	a. +200.00mV ± 6 dig b. -200.00mV ± 6 dig c. +100.00mV ± 4 dig	Display
9.	Check		Set instrument in position V ∴ Select: MAN ranging : 200V range	a. +200V ± 0,005% b. -200V ± 0,005% c. +100V ± 0,005% supplied to V Ω mA and 0 socket	a. +200.00V ± 6 dig b. -200.00V ± 6 dig c. +100.00V ± 4 dig	Display
10.	Check		Set instrument in position V ∴ Select: MAN ranging : 2000V range	+1000V ± 0,005% supplied to V Ω mA and 0 socket	+1000.0V ± 4 dig	Display

3.2. AC RANGES

No.	Adjustment	Adjusting element	Preparations	Input signals	Adjusting data	Measuring points
11a.	AC ranges 20V ~ range	Resistor R312, coarse (MR25, 1% E96 signal Potentiometer R310, fine	Set instrument in position V ~ Select: MAN ranging : 20V range	20V ~ 60Hz ± 0,01% supplied to V Ω mA and 0 socket	~ 20.000V ± 2 dig	Display
11b.	2V ~ range	Trimming capacitor C103 <i>NOTE: If the adjustment cannot be made then cut away capacitor C105 (= 3,9pF) or replace it and repeat adjustment 11.</i>	Set instrument in position V ~ Select: MAN ranging : 2V range	2V ~ 1kHz ± 0,01% supplied to V Ω mA and 0 socket	~ 2.0000V ± 5 dig	Display
12.	20V ~ range	Trimming capacitor C106 <i>NOTE: If the adjustment cannot be made then cut away capacitor C108 (= 18pF) or replace it and repeat adjustment 12.</i>	Set instrument in position V ~ Select: MAN ranging : 20V range	20V ~ 1kHz ± 0,01% supplied to V Ω mA and 0 socket	~ 20.000V ± 5 dig	Display
13.	200V ~ range	Trimming capacitor C109 <i>NOTE: If the adjustment cannot be made then cut away capacitor 111 to 113 (C111= 82pF C112 = 150pF C113 = 270pF) or replace them and repeat adjustment 13.</i>	Set instrument in position V ~ Select: MAN ranging : 200V range	200V ~ 1kHz ± 0,01% supplied to V Ω mA and 0 socket	~ 200.00V ± 5 dig	Display
14.	Check		Set instrument in position V ~ Select: MAN ranging : 200mV range	a. 200mV 60Hz ± 0,01% b. 20mV 60Hz ± 0,01% supplied to V Ω mA and 0 socket	~ 200.00mV ± 150 dig ~ 020.00mV ± 20 dig	Display

3.3. TRIGGER LEVEL RANGES

No.	Adjustment	Adjusting element	Preparations	Input signals	Adjusting data	Measuring points
15.	Comparator Trigger level ranges	Potentiometer R502	Set instrument in position TRIGGER LEVEL Select: +2V range	~ 1,414V 10kHz ± 0,01%	Adjust potentiometer R502 so that the word "gate" lights up Note down the reading of the display without polarity (value 1)	Display
16.	Comparator	Potentiometer R502	Set instrument in position TRIGGER LEVEL Select: -2V range	~ 1,414V 10kHz ± 0,01%	Adjust potentiometer R502 so that the word "gate" lights up Note down the reading of the display without polarity (value 2)	Display
17.	Comparator	Potentiometer R521	Set instrument in position TRIGGER LEVEL Select: + 2V range Adjust the display with R502 on: $\frac{\text{value 1} + \text{value 2}}{2} \pm 3 \text{ dig}$	~ 1,414V 10kHz ± 0,01%	Adjust potentiometer R521 so that the word "gate" lights ups	Display

3.4. CURRENT RANGES

No.	Adjustment	Adjusting element	Preparations	Input signals	Adjusting data	Measuring points
18.	I-V convertor	Potentiometer R213	Set instrument in position A ... Select: MAN ranging : 2 mA range		$\pm 0.000\text{mA} \pm 1$ dig	Display
		Potentiometer R227	Select: MAN ranging : $2\mu\text{A}$ range		$\pm 0.000\mu\text{A} \pm 1$ dig	Display
		Resistor R202; coarse (MR25, 1%, E96 series) Potentiometer R203, fine	Select: MAN ranging : 2A range	+ 2A ... $\pm 0,1\%$ supplied to 0,2-10A and 0 socket	+ 2.000A ± 1 dig	Display
<p><i>NOTE: Light on the diodes V251, and V252 can influence the adjustment. Protect the diodes against light.</i></p> <p><i>NOTE: The high current ranges (0,2-10A) are selected by connecting the leads between the 0 socket and the 0,2-10A socket and the up/down buttons.</i></p>						
19.	Checks current		Set instrument in position A ... Select: MAN ranging : $2\mu\text{A}$ range	+ $2\mu\text{A} \pm 0,1\%$	+ 2.000 $\mu\text{A} \pm 7$ dig	Display
			Select: MAN ranging : 20 μA range	+ 20 $\mu\text{A} \pm 0,1\%$	+ 20.00 $\mu\text{A} \pm 4$ dig	Display
			Select: MAN ranging : 200 μA range	+ 200 $\mu\text{A} \pm 0,1\%$	+ 200.00 $\mu\text{A} \pm 4$ dig	Display
			Select: MAN ranging : 2mA range	+ 2mA $\pm 0,1\%$	+ 2.000mA ± 4 dig	Display
			Select: MAN ranging : 20mA range	+ 20mA $\pm 0,1\%$	+ 20.00mA ± 4 dig	Display
			Select: MAN ranging : 20mA range	- 20mA $\pm 0,1\%$	- 20.00mA ± 4 dig	Display
			Set instrument in position A ... Select: MAN ranging : 20mA range	$\sim 20\text{mA}$ 60Hz $\pm 0,2\%$	$\sim 20.00\text{mA} \pm 7$ dig	Display
				supplied to V Ω mA and 0 socket		

3.5. RESISTANCE RANGES

No.	Adjustment	Adjusting element	Preparations	Input signals	Adjusting data	Measuring points
20.	Resistance ranges 20M Ω range	Potentiometer R405	Set instrument in position Ω Select: MAN ranging : 20M Ω range	20M Ω \pm 0,1%	20.000M Ω \pm 10 dig	Display
21.	Checks resistance ranges		Set instrument in position Ω Select: MAN ranging : 200 Ω range Select: MAN ranging : 2k Ω range Select: MAN ranging : 20k Ω range Select: MAN ranging : 200k Ω range Select: MAN ranging : 2M Ω range	200 Ω \pm 0,1% 2k Ω \pm 0,1% 20k Ω \pm 0,1% 200k Ω \pm 0,1% 2M Ω \pm 0,1%	200.00 Ω \pm 35 dig 2.0000k Ω \pm 35 dig 20.000k Ω \pm 35 dig 200.00k Ω \pm 35 dig 2.0000M Ω \pm 80 dig	Display Display Display Display Display Display

3.6. TEMPERATURE RANGES

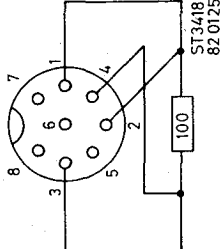
No.	Adjustment	Adjusting element	Preparations	Input signals	Adjusting data	Measuring points
22.	Temperature ranges 0°C calibration	Potentiometer R708 <i>NOTE: The resistor should be connected as shown</i>	Set instrument in 0°C	100Ω ± 0,1% to the PROBE input 	± 0000.0 ± 1 dig	Display

3.7. FREQUENCY RANGES

23.	Hz ranges Check 10kHz range		Set instrument in position TRIGGER LEVEL Select: + 2V range and adjust it to: ± 50mV + 0.000V Set instrument in position Hz Select: MAN ranging : 10kHz range	100mV, 9kHz ± 0,01%	GATE 9.0000kHz ± 300 dig	Display
-----	--------------------------------	--	---------------------------------------------------------------------------------------------------------------------------------------------------------------------------------------	---------------------	--------------------------	---------

3.8. TIME RANGES

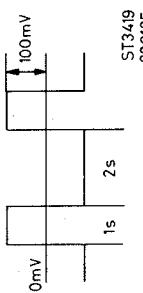
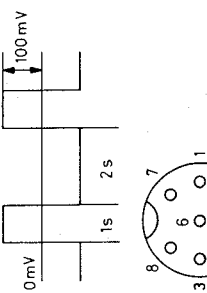
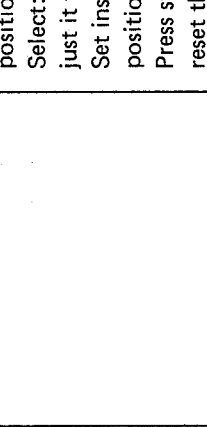
No.	Adjustment	Adjusting element	Preparations	Input signals	Adjusting data	Measuring points
24a.	s ranges Check s range		Set instrument in position TRIGGER LEVEL Select: + 2V range and adjust it to + 0.000V \pm 50mV Set instrument in position s Press stop reset button to reset the PM2521.	(e.g.) 	3.0000 s	Display
24b.			Set instrument in position TRIGGER LEVEL Select: - 2V range and adjust it to 0.000V \pm 50mV Set instrument in position s Press stop reset button to reset the PM2521 Connect point 5 and point 7 from the PROBE input together	(e.g.) 	2.0000 s	Display
24c.			Set instrument in position TRIGGER LEVEL Select: + 2V range and adjust it to: \pm 50mV + 0.000V Set instrument in position s Press stop reset button to reset the PM2521 Connect point 5 and point 7 from the PROBE input together.	(e.g.) 	1.0000 s	Display

NOTE: Adjustment 24b. and 24c. are special TRIGGER MODES. Refer to chapter 6 of the OPERATING MANUAL.

4. FAULT-FINDING

4.1. GENERAL

4.1.1. Service hints

If servicing is necessary the following points should be taken into account in order to avoid damaging the instrument.

- Take care to avoid short-circuits with measuring clips and hooks if the instrument is switched-on, especially near the input terminals when high-voltages are present.
- Use a miniature soldering iron (35W max.) with a thin cleaner or a vacuum soldering iron.
- Use an acid-free solder.
- When fault-finding, remove top and bottom covers and make sure that the POWER SUPPLY is connected with the main board.
- After repair, the instrument should be recalibrated.

4.1.2. Fault-finding procedure

This chapter gives a fault-finding procedure to locate the faulty section in the instrument. From this procedure the faulty parts can often be found by using the detailed flow charts.

NOTE: The procedure is only intended as an aid to fault-finding, and obviously that the faulty component will not be found in every case.

Measuring instruments used:

- Digital multimeter.
- Oscilloscope.
- Counter.

4.1.3. Fault-finding with the signature analyser

When the normal fault-finding does not find the fault, then it is possible to use a test-ROM.

The testrom with several tests for the PM2521 is based on signature analysis. It can trace faults at component level for the controller section, display section and even a part of the analog section.

The signature analysis fault-finding consists of a:

- Testrom with the following tests:
 - Free run tests
 - RAM and I/O test
 - Visual L.C.D. test (no S.A.)
 - Switch decoding test
 - Relay/FET test
 - Static relay/FET test (no S.A.)
 - Counter test
 - Interrupt controller test
- Test service note which includes:
 - Description of how to use the signature analyser
 - Circuit diagrams with signatures

The test-ROM and the service note can be ordered from Concern Service under code nr. 5322 694 54013.

4.2. FAULT-FINDING FLOW-CHARTS

4.2.1. Basic check

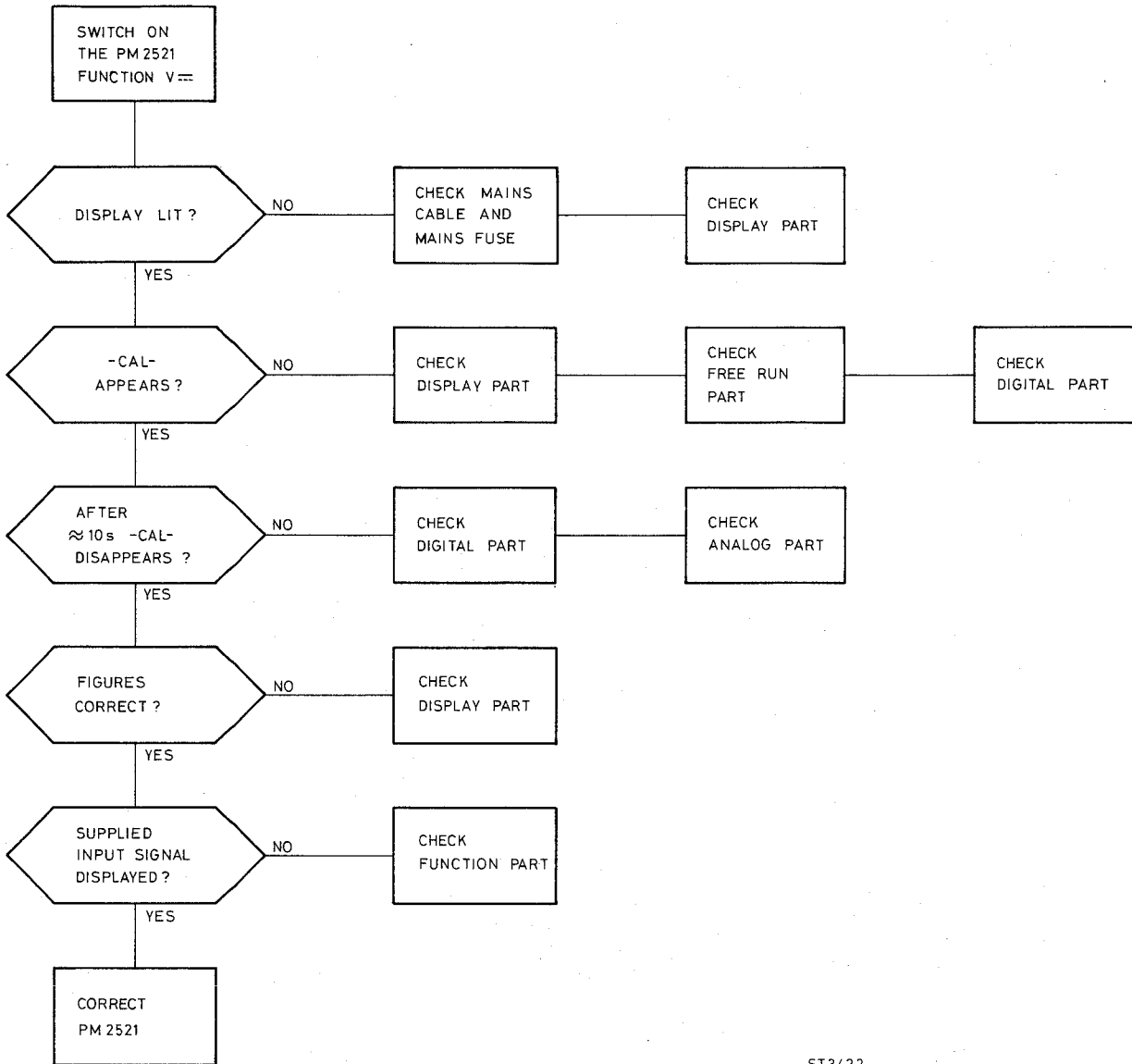

ST3422
820126

4.2.2. Function part

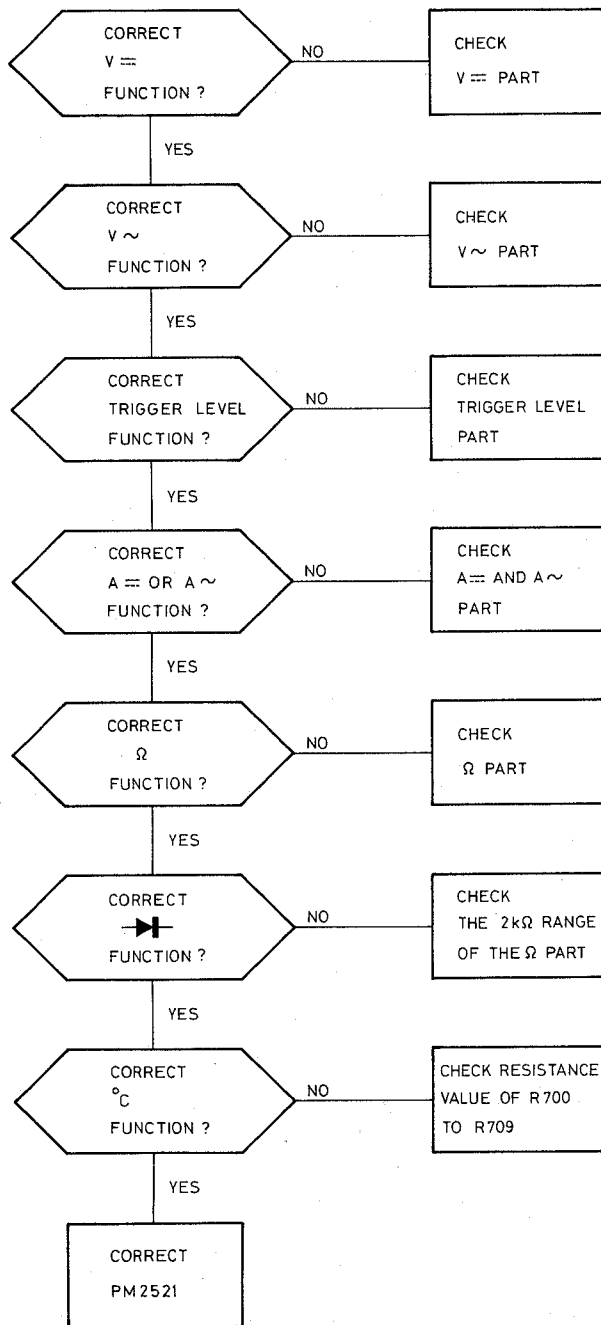
ST3423
820128

4.2.3. V Ω part

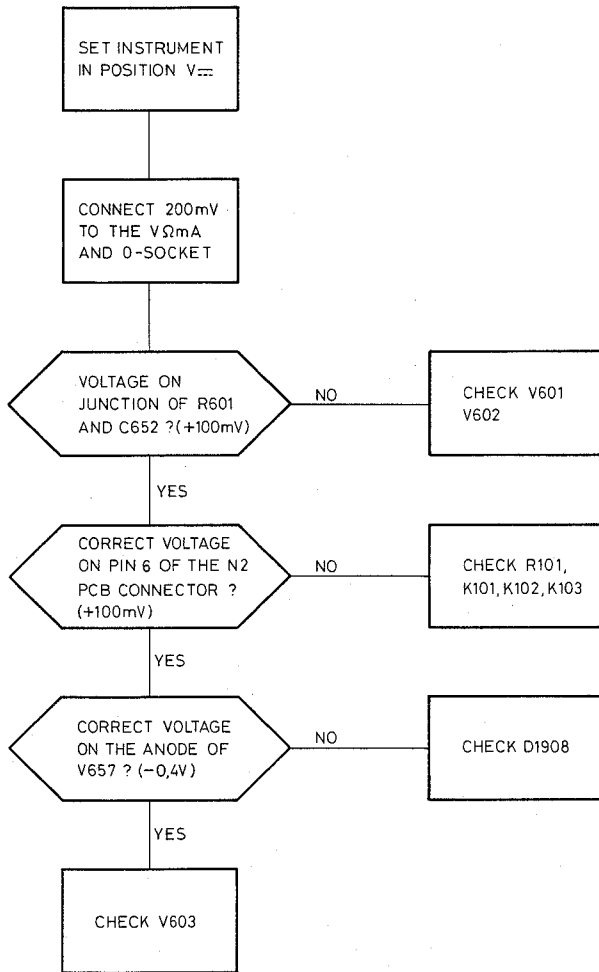

NOTE : THE VOLTAGE ON THE N2 PCB CONNECTOR MUST BE MEASURED WITH A HIGH IMPEDANCE VOLTMETER (100MΩ) IF THIS IS NOT POSSIBLE, TAKE ACCOUNT OF THE SHUNTING EFFECT (INPUT IMPEDANCE PM2521= 10MΩ).

NOTE : MEASUREMENT ZERO IS THE 0-SOCKET OF THE PM2521

ST3424
820204

4.2.4. V ~ part

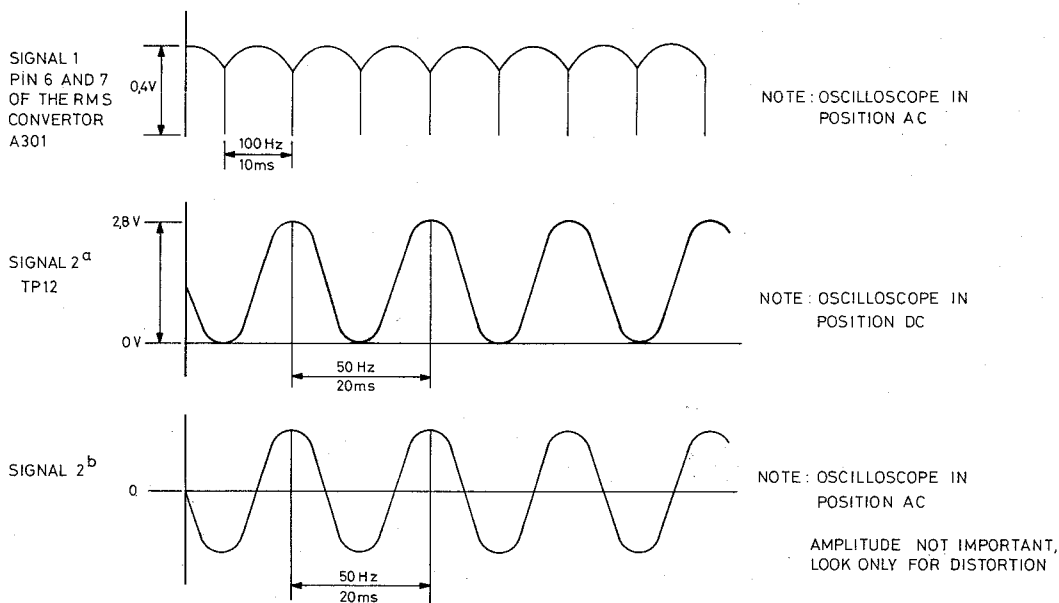

ST3426
820209

Fig. 47. Waveforms V ~ part

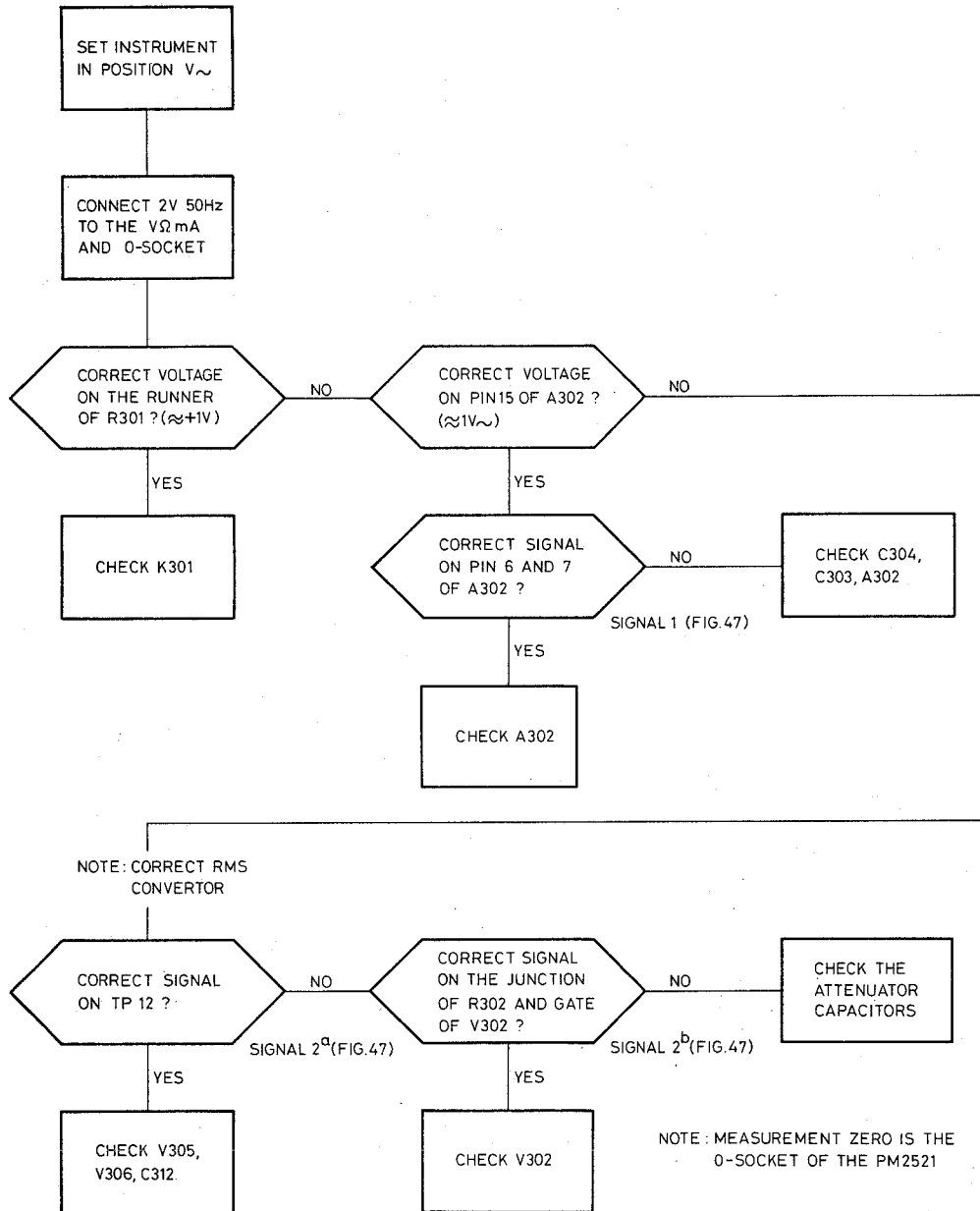

4.2.5. Trigger level part

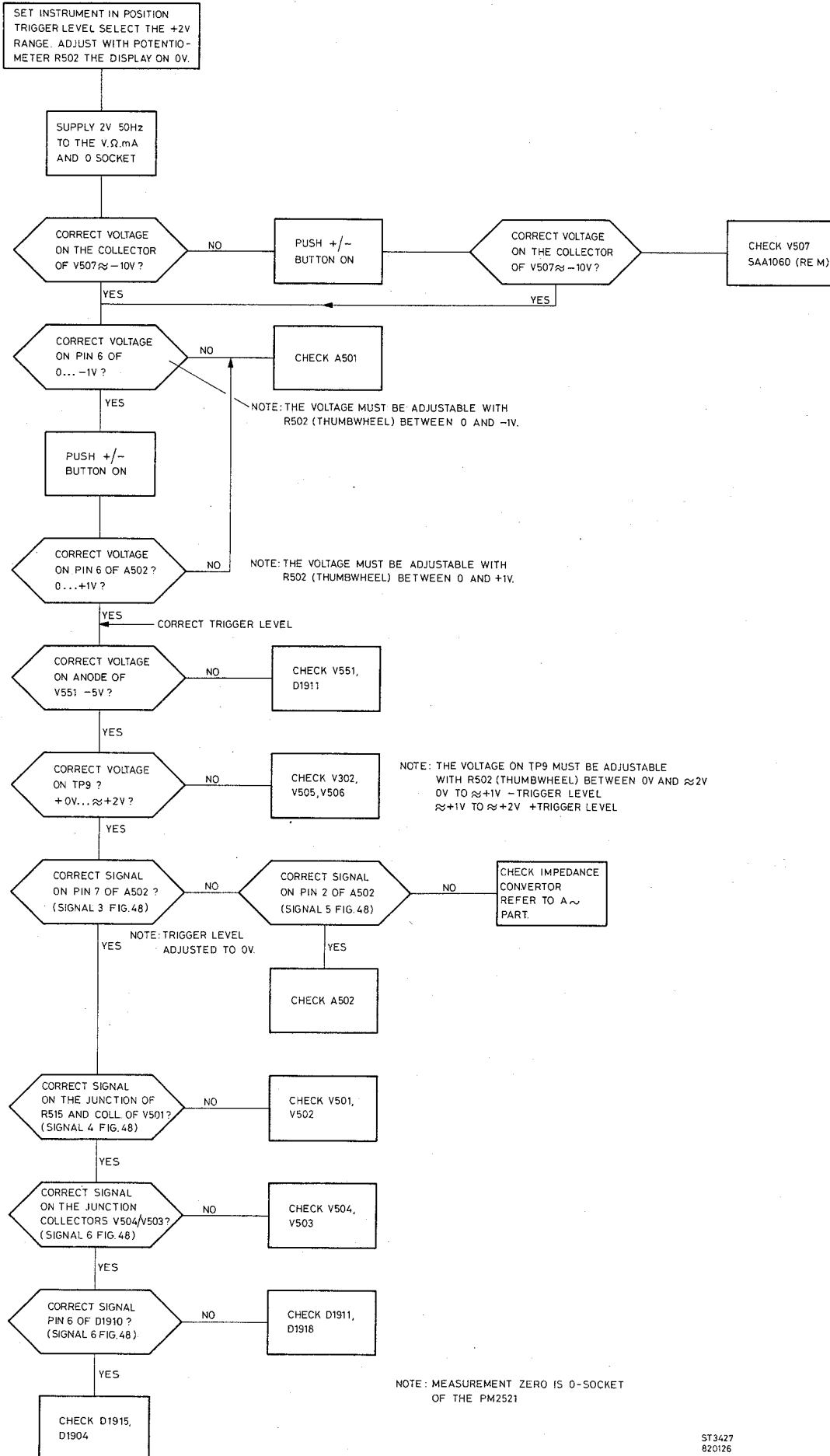

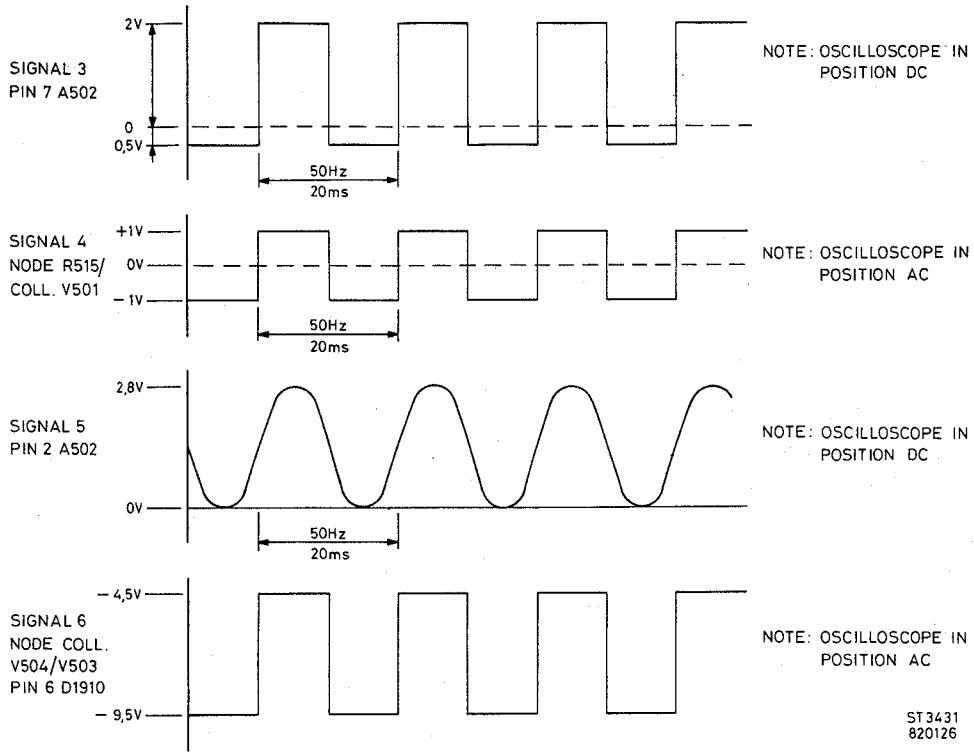
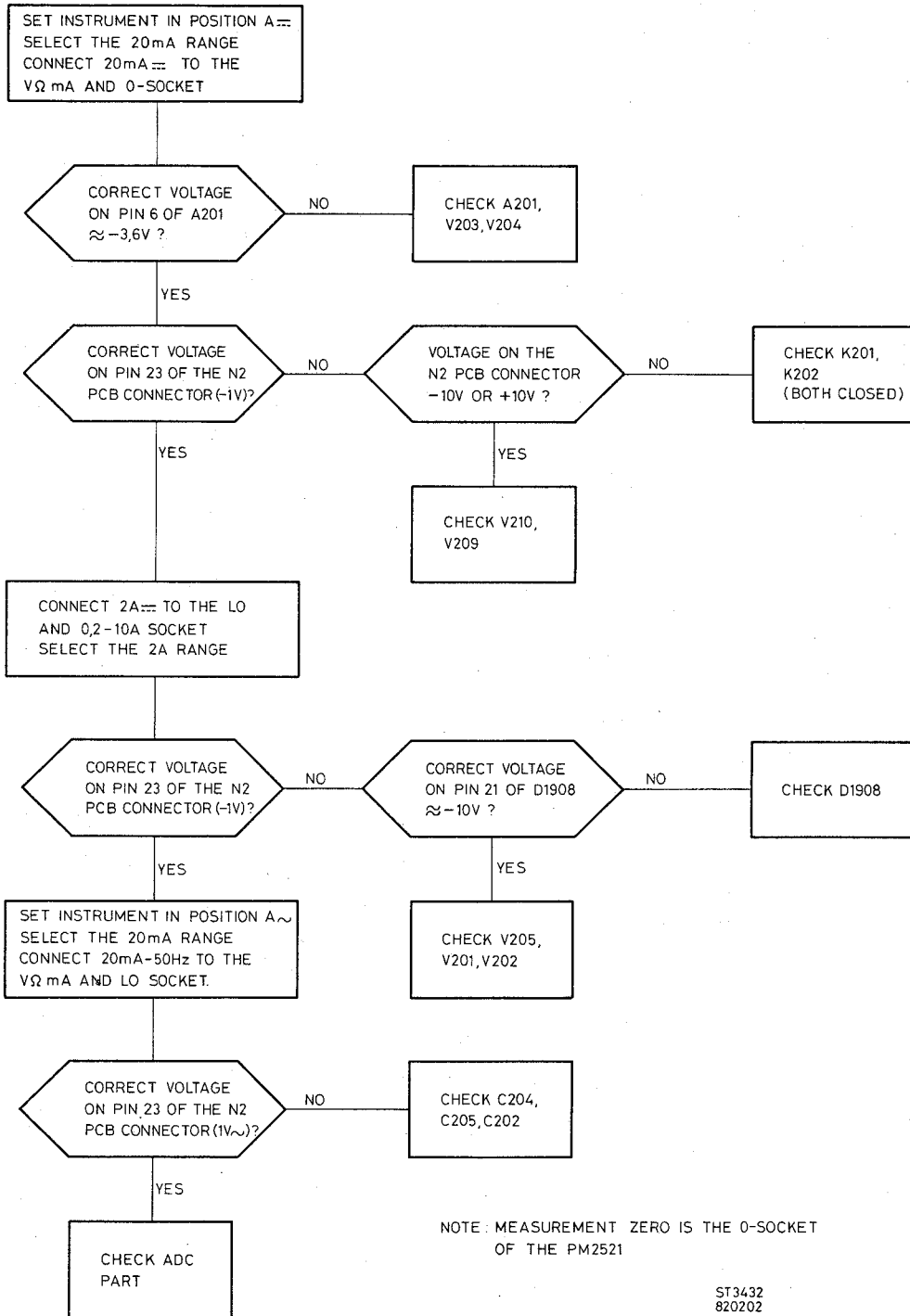

Fig. 48 Waveforms, trigger level part

4.2.6. A \approx and A \sim part



4.2.7. Ω part

SET INSTRUMENT IN POSITION Ω
CONNECT AN AMMETER TO THE
V Ω mA AND 0-SOCKET

		D1908				
		PIN 21	PIN 10	PIN 16	PIN 13	
		RNG C	RNG D	RNG E	RNG B	
SELECT RANGE	200 Ω	$\rightarrow I = -1\text{mA}$	-10V	-10V	0V	-10V
"	2k Ω	$\rightarrow I = -1\text{mA}$	-10V	-10V	0V	+4V
"	20k Ω	$\rightarrow I = 100\mu\text{A}$	-10V	-10V	-10V	+4V
"	200k Ω	$\rightarrow I = -10\mu\text{A}$	0V	-10V	-10V	+4V
"	2M Ω	$\rightarrow I = -1\mu\text{A}$	-10V	0V	-10V	+4V
"	20M Ω	$\rightarrow I = -100\text{nA}$	0V	0V	-10V	+4V

NOTE: IN THE 200 Ω RANGE THE 0,1V RANGE OF THE ADC IS SELECTED

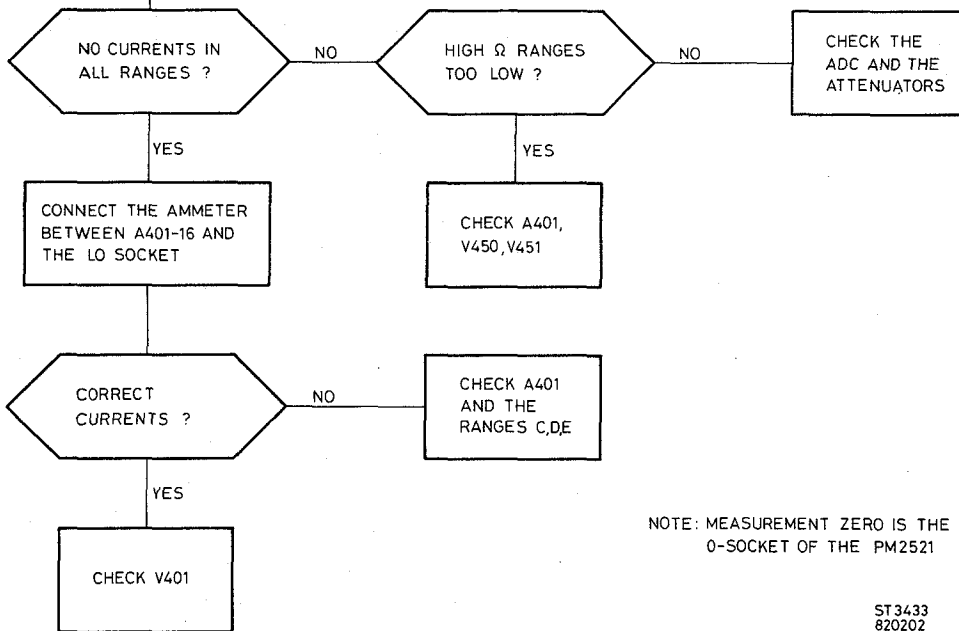

NOTE: MEASUREMENT ZERO IS THE
0-SOCKET OF THE PM2521

ST3433
820202

4.2.8. Analog part

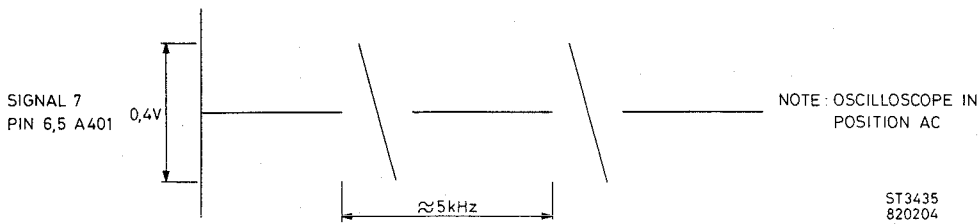
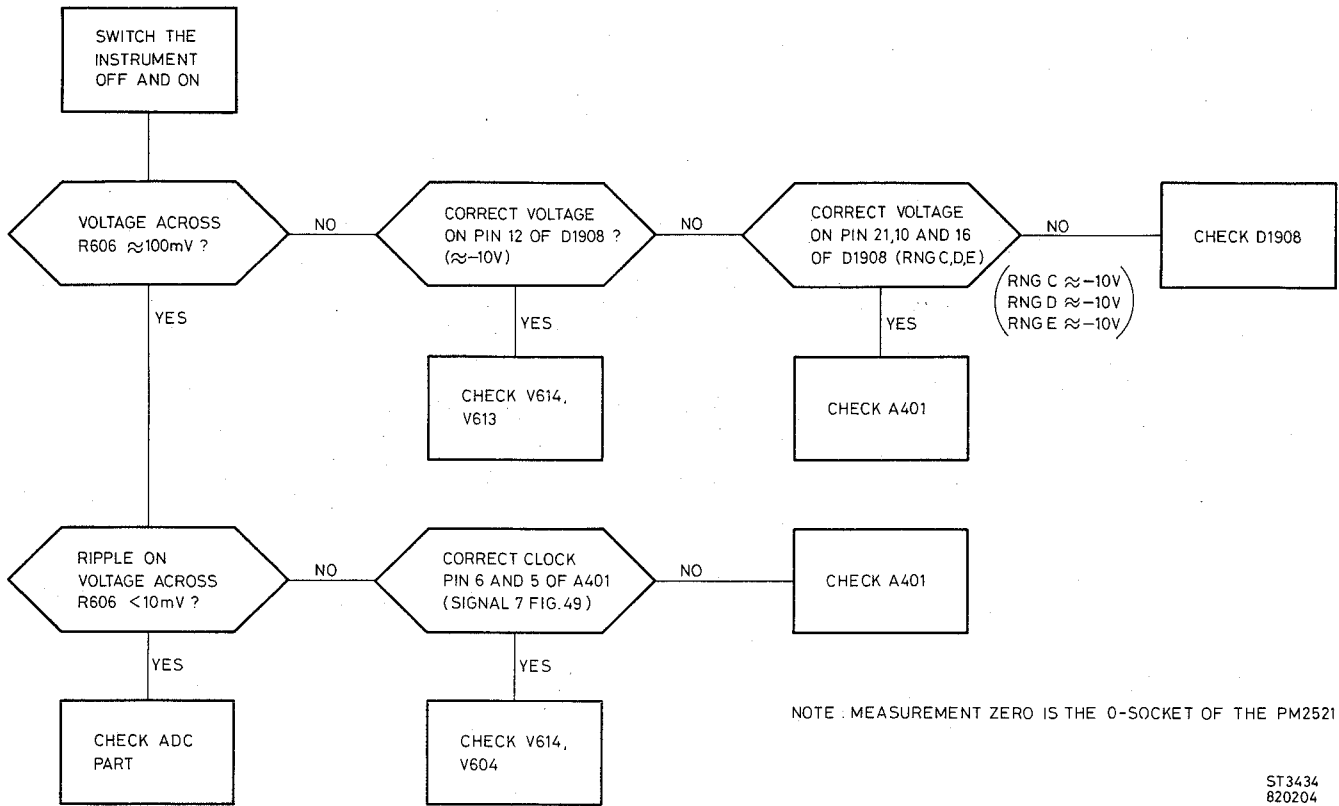
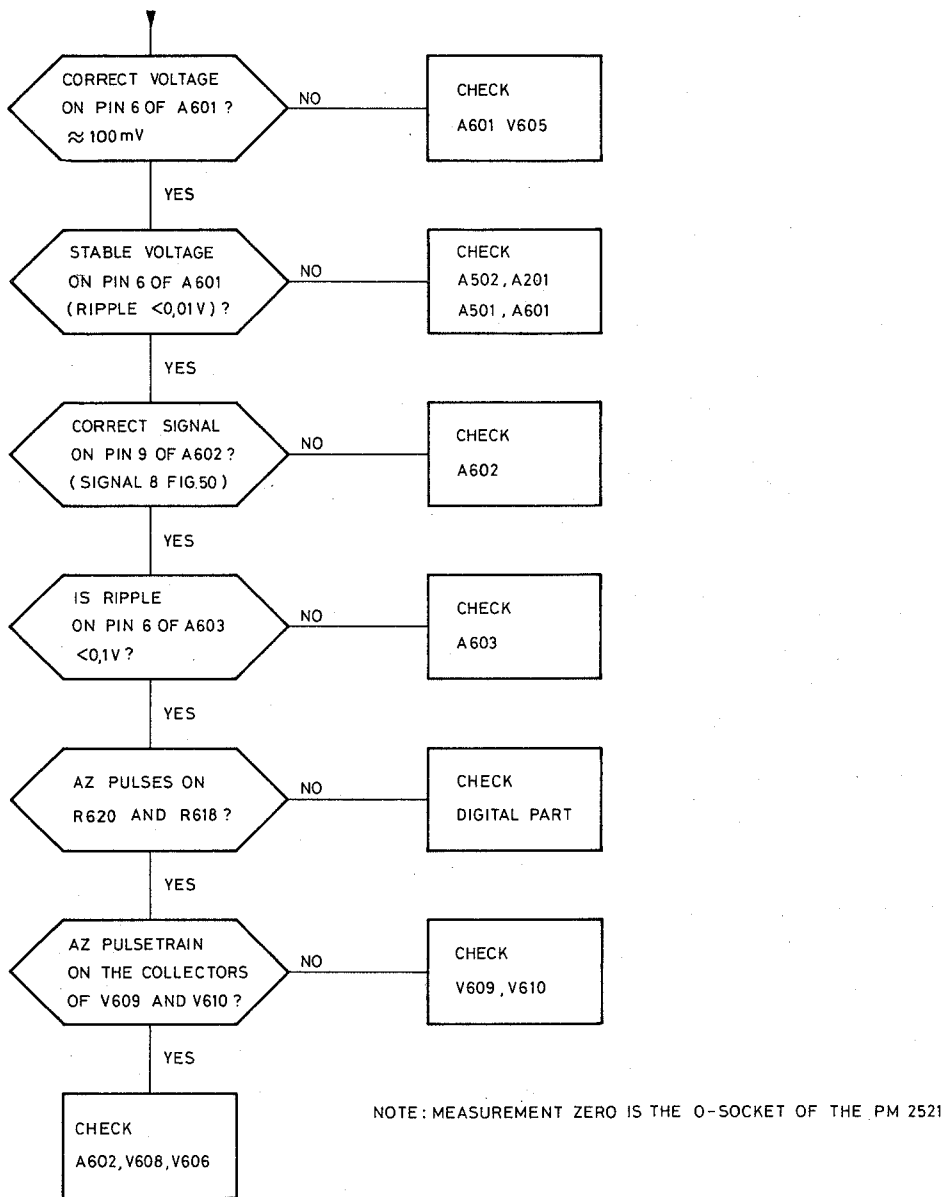

Fig. 49. Waveform, analog part

4.2.9. ADC part



ST 3436
820128

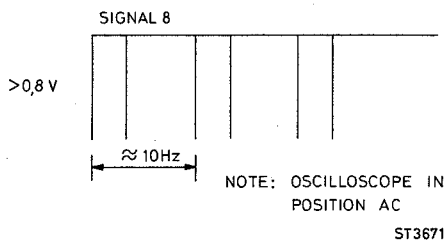

Fig. 50. Waveform, ADC part

4.2.10. Digital part

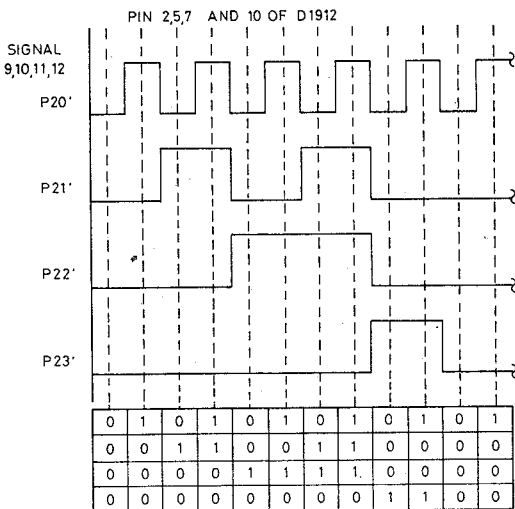
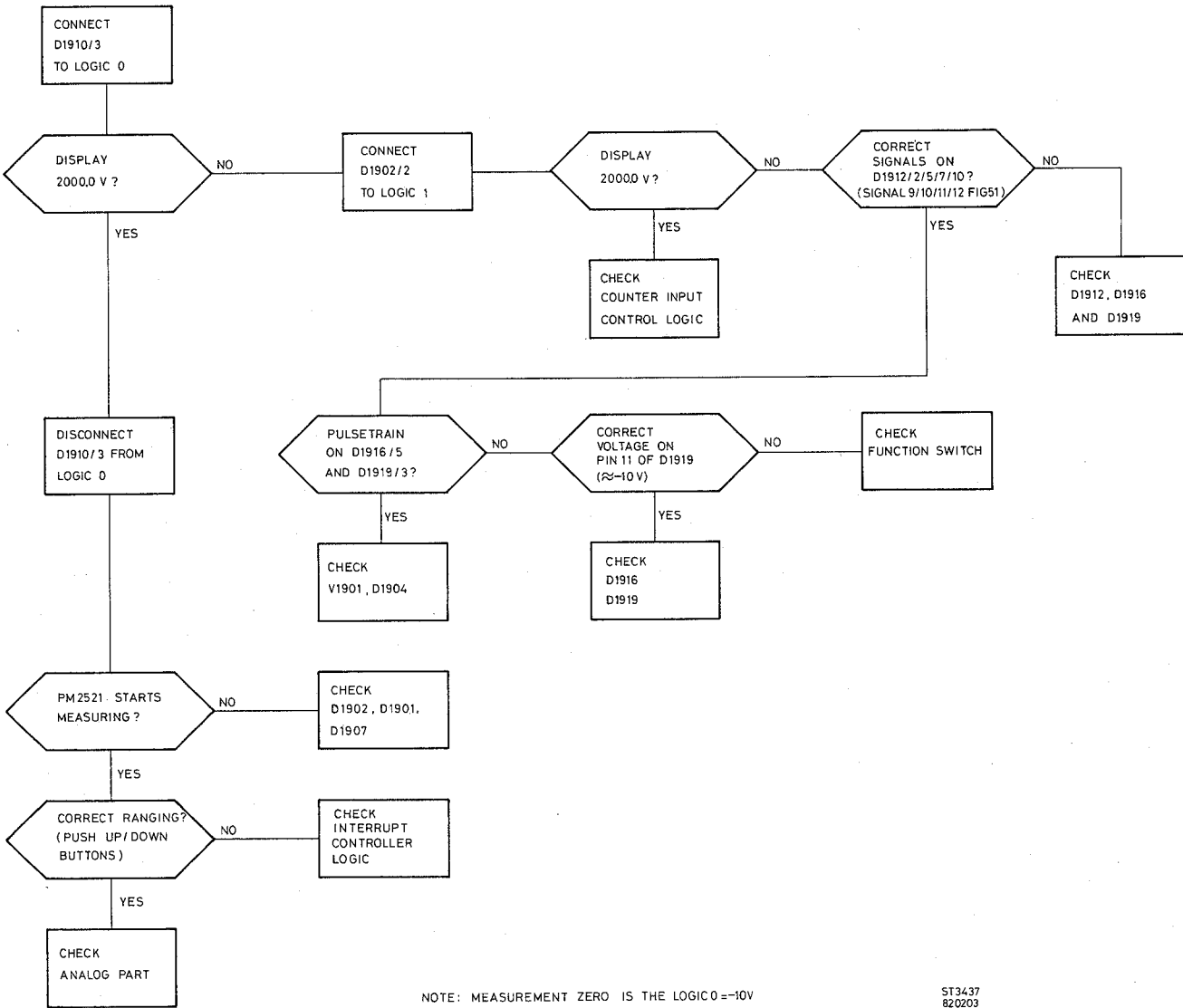
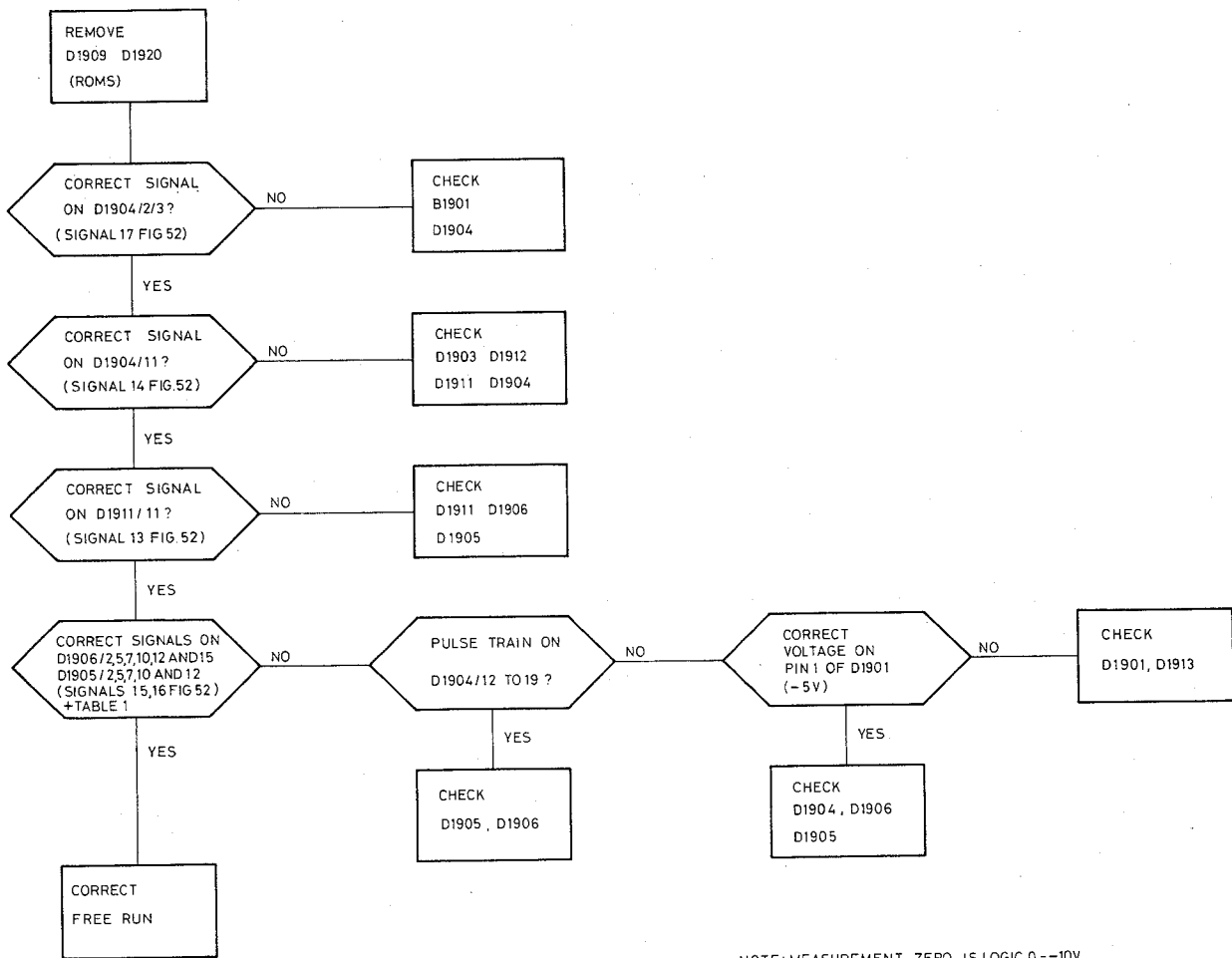

Fig. 51 Waveforms, digital part

4.2.11. Free run



NOTE: MEASUREMENT ZERO IS LOGIC 0 = -10V.

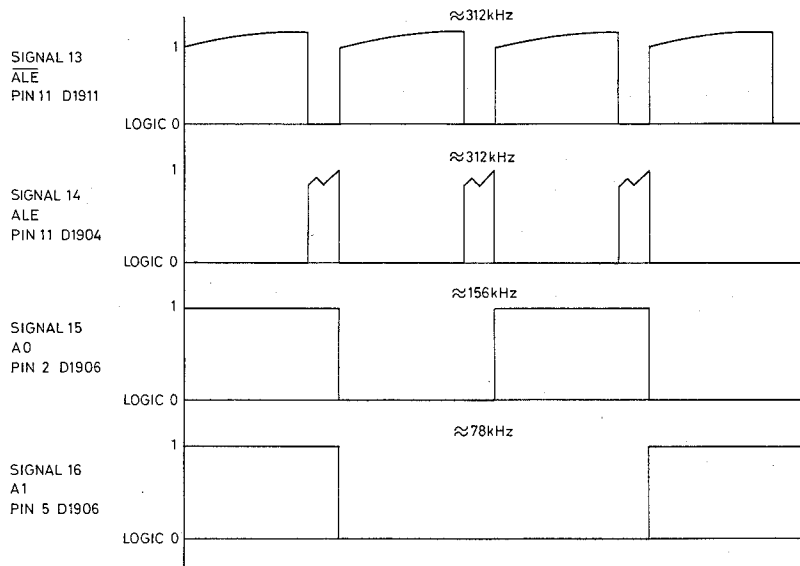
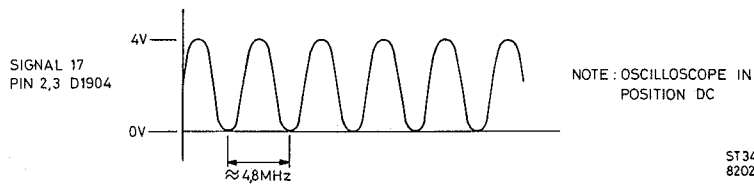

TABLE 1

ADDR.	FREQ.	PIN	ADDR.	FREQ.	PIN
A0	156kHz	D1906-2	A6	2437Hz	D1905-2
A1	78kHz	D1906-5	A7	1219Hz	D1905-5
A2	39kHz	D1906-7	A8	609Hz	D1905-7
A3	19,5kHz	D1906-10	A9	305Hz	D1905-10
A4	9750Hz	D1906-12	A10	152Hz	D1905-12
A5	4875Hz	D1906-15			



ST3440
820208

Fig. 52. Waveforms, free run

4.2.12. Display part

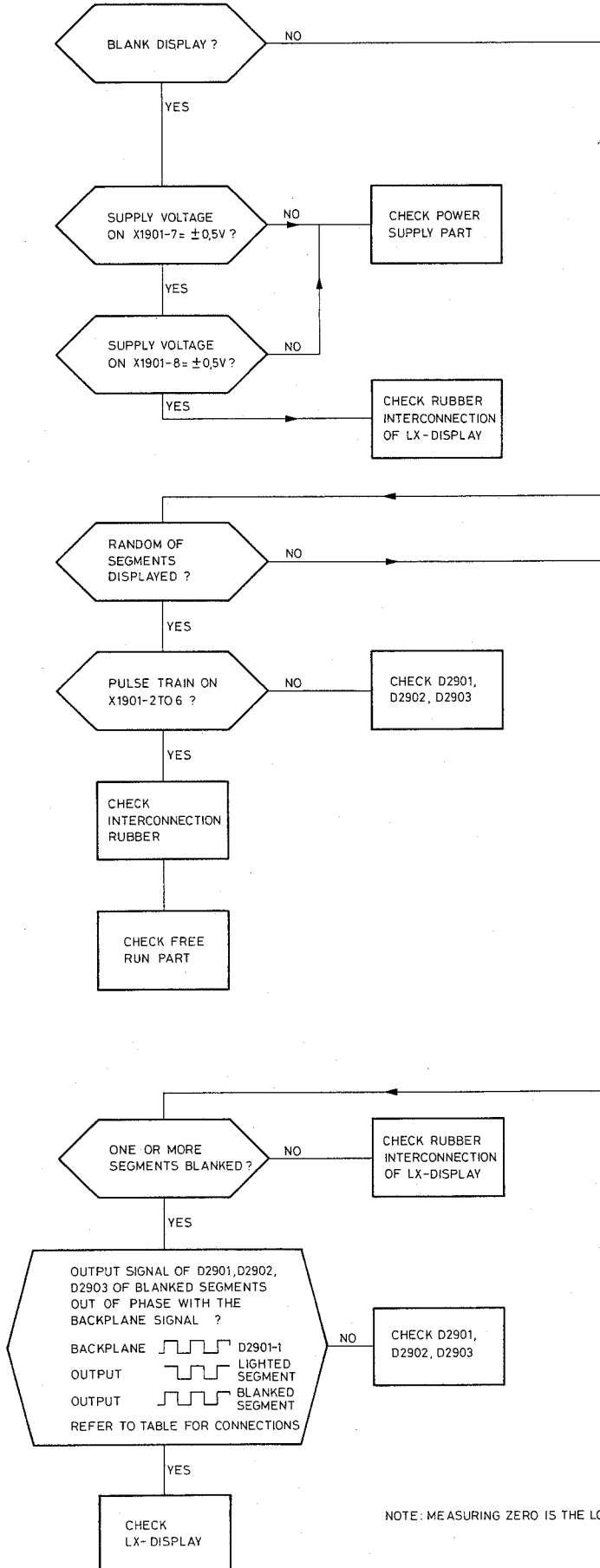

CONNECTION TABLE

CONNECTIONS D2901 D2902 D2903		D2901	LX-display	D2902	LX-display	D2903	LX-display
Output no.	Pin no.	Char.	Pin no.	Char.	Pin no.	Char.	Pin no.
Q1	9		2	.3	22	a5	42
Q2	10	-	3	d3	23	b5	43
Q3	11	+	4	e3	24	g5	44
Q4	12	GATE	5	f3	25	c5	45
Q5	13	.1	6	a3	26	M (Hz)	46
Q6	14	d1	7	b3	27	k (Hz)	47
Q7	15	e1	8	g3	28	Hz	48
Q8	16	f1	9	c3	29	Z	49
Q9	17	a1	10	.4	30	s	50
Q10	18	b1	11	d4	31	V	51
Q11	19	g1	12	e4	32	A	52
Q12	20	c1	13	f4	33	*	53
Q13	21	.2	14	a4	34	m	54
Q14	22	d2	15	b4	35	μ	55
Q15	23	e2	16	g4	36	$^{\circ}\text{C}$	56
Q16	24	f2	17	c4	37	Ω	57
Q17	25	a2	18	.5	38	k (Ω)	58
Q18	26	b2	19	dB	39	M (Ω)	59
Q19	27	g2	20	e5	40	n.c.	-
Q20	28	c2	21	f5	41	n.c.	-

4.2.13. Power supply check



NOTE: MEASURING ZERO IS 0-SOCKET OF PM2521

5. PARTS LIST

5.1. TOP COVER ASSEMBLY

	Ordering number	Qty.	Item	Fig.
Cover with screening	5322 694 54012	1	4	45
Transformer	5322 146 24485	1		45
Mains connector	5322 267 44135	1		45
Fuse 125mA	4822 253 20007	1		
Thermal fuse	5322 252 20088	1		45

5.2. BOTTOM COVER ASSEMBLY

Cover with screening and feet	5322 447 70045	1	5	42
Rubber foot	5322 462 44484	1		
Carrying handle	5322 498 50126	1		

5.3. FRONT ASSEMBLY

Front	5322 447 74009	1	9	44
T.L. potentiometer knob	5322 414 34269	1	10	44
Function selector	5322 414 44088	1	4	44
Window	5322 381 10562	1	11	44
L.C. display	5322 130 94033	1	1	44
Interconnection rubber	5322 290 84029	1	3	44
Display unit N3	5322 216 74066	1	2	44
Ball	4822 520 40044	1	12	44

5.4. SWITCH ASSEMBLY

N2 printed circuit board	5322 466 10315	1	6	42
Function switch complete	5322 278 80175	2	7	42
VRPP connector X101	5322 267 74125	1	8	42

5.5. PRINTED CIRCUIT BOARD

5.5.1. Miscellaneous

	Ordering number	Qty.	Item	Fig.
Power switch	5322 276 84077	1	13	44
Knob power switch	5322 414 26415	1	13	44
+/- switch SK1	5322 276 14417	1	14	44
Auto switch SK2	5322 276 14417	1	14	44
Down switch SK3	5322 276 14417	1	14	44
Up switch SK4	5322 276 14417	1	14	44
Switch for high current ranges	5322 492 62405	1		53
Push button knobs	5322 414 26416	4	14	44
10p connector male X801	5322 264 54061	1	15	42
5p connector male X802	5322 264 44064	1	16	42
10p connector female X1901	5322 266 44028	1	17	42
8p DIN connector BU3	5322 267 54107	1	15	44
Input sockets	5322 532 14709	3	16	44
Coil L801	5322 158 10052	1	18	42
Crystal B1901	5322 242 74404	1	19	42
Reed relay K101	5322 280 24146	1		
Reed relay K102	5322 280 24146	1		
Reed relay K201	5322 280 24146	1		
Reed relay K301	5322 280 24146	1		
Reed relay K602	5322 280 24146	1		

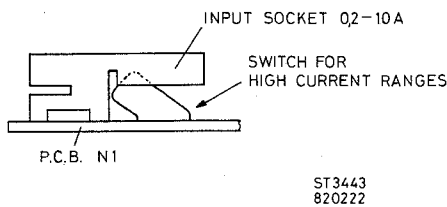

Fig. 53. Switch for high current range

5.5.2. Resistors

POSNR	DESCRIPTION	ORDERING CODE
R 1	10A SHUNT	5322 115 84046
R 101	THIN FILM RESISTANCE	5322 209 86478
R 102	71K5 1% 0,4W	5322 116 54685
R 103	100K CARB LIN 0,05W	4822 100 10052
R 105	11K5 1% 0,4W	5322 116 55358
R 106	215E 1% 0,4W	5322 116 55274
R 107	681K 1% 0,4W	5322 116 55284
R 108	47K CARB LIN 0,1W	5322 101 34037
R 201	18E7 1% 0,4W	5322 116 50895
R 203	1K CARB LIN 0,1W	4822 100 10037
R 204	38,3K 0,5% 0,5W	5322 116 55576
R 205	38K3 0,5% 0,5W	5322 116 55576
R 206	590K 1% 0,5W	5322 116 55567
R 207	590E 1% 0,4W	5322 116 50561
R 208	1M 5% CR25	4822 110 73187
R 209	40K2 1% 0,4W	5322 116 54665
R 210	59K0 1% 0,4W	5322 116 54678
R 211	162E 1% 0,4W	5322 116 50417
R 212	649K 1% 0,4W	5322 116 55331
R 213	100K CARB LIN 0,05W	4822 100 10052
R 214	100E 0,1% 0,125W	5322 116 50268
R 215	100E 0,1% 0,125W	5322 116 50268
R 216	4K81 0,1% 0,1W	5322 116 55578
R 217	140E 0,5% 0,4W	5322 116 55568
R 218	481K 0,1% 0,125W	5322 116 55565
R 219	14K 0,5% 0,4W	5322 116 55571
R 220	10K 1% 0,4W	4822 116 51253
R 221	100E 20% 265VR	4822 116 40006
R 222	51K1 0,5% 0,5W	5322 116 55577
R 223	750-1K5 245VR	5322 116 44006
R 224	422K 1% 0,4W	5322 116 55247
R 225	100K 1% 0,4W	4822 116 51268
R 226	100K 1% 0,4W	4822 116 51268
R 227	100K CARB LIN 0,05W	4822 100 10052
R 228	110E 1% 0,4W	5322 116 54474
R 229	110E 1% 0,4W	5322 116 54474
R 231	1MOHM 1% 0,4W	5322 116 55535
R 232	1MOHM 1% 0,4W	5322 116 55535
R 301	100K 1% 0,4W	4822 116 51268
R 302	1K 1% 0,4W	5322 116 54549
R 303	866E 1% 0,4W	5322 116 54543
R 304	10K 1% 0,4W	4822 116 51253
R 305	3K01 0,1% MR24E 0,1W	5322 116 54218
R 306	30K1 0,1% 0,1W	5322 116 51392
R 307	33E2 1% 0,4W	5322 116 50527
R 308	100K 1% 0,4W	4822 116 51268
R 309	44E2 1% 0,4W	5322 116 50818
R 310	220E CARB LIN 0,05W	4822 100 10019
R 311	8K25 1% 0,4W	5322 116 54558
R 313	1K 1% 0,4W	5322 116 54549
R 314	31K6 1% 0,4W	5322 116 54657
R 315	100K 1% 0,4W	4822 116 51268
R 317	590E 1% 0,4W	5322 116 50561
R 318	1K 1% 0,4W	5322 116 54549
R 319	100K 1% 0,4W	4822 116 51268
R 320	10K 1% 0,4W	4822 116 51253
R 401	100E 20% 256VR	4822 116 40006
R 402	1K 1% 0,4W	5322 116 54549
R 403	19,6M 1% VR37R	5322 116 64131
R 404	2K87 1% 0,4W	5322 116 50414
R 405	100E CARB LIN 0,05W	4822 100 10075

POSNR	DESCRIPTION			ORDERING	CODE
R 406	2K87	1%	0,4W	5322 116	50414
R 407	1K	1%	0,4W	5322 116	54549
R 408	121K	0,1%	0,125W	5322 116	55245
R 409	590E	1% 0,4W		5322 116	50561
R 410	16K9	0,1%	0,1W	5322 116	54833
R 411	47K CARB LIN		0,05W	4822 100	10036
R 413	100K	1%	0,4W	4822 116	51268
R 414	100K	1%	0,4W	4822 116	51268
R 415	33K2	1%	0,4W	4822 116	51259
R 416	100K	1%	0,4W	4822 116	51268
R 417	10K	1%	0,4W	4822 116	51253
R 418	215K	1%	0,4W	5322 116	54728
R 502	47K	20%	0,1W	5322 101	34036
R 503	4K64	1%	0,4W	5322 116	50484
R 504	30K1	1%	0,4W	5322 116	54655
R 505	13K3	1%	0,4W	5322 116	55276
R 506	51E1	1%	0,4W	5322 116	54442
R 507	10K	0,5%	0,4W	4822 116	51253
R 508	51E1	1%	0,4W	5322 116	54442
R 509	10K	1%	0,4W	4822 116	51253
R 510	2K05	1%	0,4W	5322 116	50664
R 511	10K	1%	0,4W	4822 116	51253
R 512	10K	1%	0,4W	4822 116	51253
R 513	511E	1%	0,4W	4822 116	51282
R 514	1K	1%	0,4W	5322 116	54549
R 515	3K01	1%	0,4W	4822 116	51246
R 516	1K	1%	0,4W	5322 116	54549
R 517	10K	1%	0,4W	4822 116	51253
R 518	23K7	1%	0,4W	5322 116	54646
R 519	121K	1%	0,4W	5322 116	54704
R 520	619E	1%	0,4W	5322 116	54529
R 521	470E CARB LIN		0,05W	4822 100	10038
R 522	590E	0,5%	0,4W	5322 116	50561
R 523	51E1	1%	0,4W	5322 116	54442
R 600	10K	0,5%	0,4W	4822 116	51253
R 601	332K	1%	0,4W	4822 116	51184
R 602	33K2	1%	0,4W	4822 116	51259
R 603	332K	1%	0,4W	4822 116	51184
R 604	56K2	1%	0,4W	4822 116	51264
R 605	56K2	1%	0,4W	4822 116	51264
R 606	1K	0,1%	0,1W	5322 116	50747
R 607	681K	1%	0,4W	5322 116	55284
R 608	100K	1%	0,4W	4822 116	51268
R 609	681E	1%	0,4W	4822 116	51233
R 610	681E	1%	0,4W	4822 116	51233
R 611	86K6	1%	0,4W	5322 116	54692
R 612	86K6	1%	0,4W	5322 116	54692
R 613	6E81	1%	0,4W	5322 116	54013
R 614	100K	1%	0,4W	4822 116	51268
R 615	10K2	1%	0,4W	5322 116	54621
R 616	1K24	1%	0,4W	5322 116	54559
R 617	681K	1%	0,4W	5322 116	55284
R 618	20K5	1%	0,4W	5322 116	54643
R 619	681K	1%	0,4W	5322 116	55284
R 620	20K5	1%	0,4W	5322 116	54643
R 621	100K	1%	0,4W	4822 116	51268

POSHR	DESCRIPTION	ORDERING	CODE
R 622	1K1 1% 0,4W	5322 116	54554
R 623	11K0 1% 0,4W	5322 116	54619
R 624	220E CARB LIN 0,05W	4822 100	10019
R 625	681K 1% 0,4W	5322 116	55284
R 626	10K 1% 0,4W	4822 116	51253
R 627	511K 1% 0,4W	5322 116	55258
R 628	100K 1% 0,4W	4822 116	51268
R 629	110E 1% 0,4W	5322 116	54619
R 701	9K53 0,5% 0,4W	5322 116	55575
R 702	9K53 0,5% 0,4W	5322 116	55575
R 703	1K43 0,5% 0,4W	5322 116	55572
R 704	15E4 0,5% 0,4W	5322 116	55573
R 705	1K4 0,5% 0,4W	5322 116	55569
R 707	619E 1% 0,4W	5322 116	54529
R 708	100E CARB LIN 0,05	4822 100	10075
R 801	2K49 1% 0,4W	5322 116	50581
R 802	1K87 1% 0,4W	5322 116	50728
R 803	7K5 1% 0,4W	5322 116	54608
R 804	464E 1% 0,4W	5322 116	50536
R 805	100E 1% 1/8W	5322 116	54469
R 806	464E 1% 0,4W	5322 116	50536
R 807	1E 1% 0,4W	4822 116	51179
R 808	2K26 1% 0,4W	5322 116	50675
R 809	100K 1% 0,4W	4822 116	51268
R 810	100K 1% 0,4W	4822 116	51268
R 811	1E 1% 0,4W	4822 116	51179
R 1901	27K4 1% 0,4W	5322 116	50559
R 1902	27K4 1% 0,4W	5322 116	50559
R 1903	27K4 1% 0,4W	5322 116	50559
R 1904	27K4 1% 0,4W	5322 116	50559
R 1905	27K4 1% 0,4W	5322 116	50559
R 1906	27K4 1% 0,4W	5322 116	50559
R 1907	27K4 1% 0,4W	5322 116	50559
R 1908	27K4 1% 0,4W	5322 116	50559
R 1909	27K4 1% 0,4W	5322 116	50559
R 1910	27K4 1% 0,4W	5322 116	50559
R 1911	1K 1% 0,4W	5322 116	54549
R 1912	27K4 1% 0,4W	5322 116	50559
R 1913	4K22 1% 0,4W	5322 116	50729
R 1914	27K4 1% 0,4W	5322 116	50559
R 1915	27K4 1% 0,4W	5322 116	50559
R 1916	27K4 1% 0,4W	5322 116	50559
R 1917	27K4 1% 0,4W	5322 116	50559
R 1918	27K4 1% 0,4W	5322 116	50559
R 1919	27K4 1% 0,4W	5322 116	50559
R 1920	27K4 1% 0,4W	5322 116	50559
R 1921	10K 1% 0,4W	4822 116	51253
R 1922	22K6 1% 0,4W	5322 116	50481
R 1923	27K4 1% 0,4W	5322 116	50559
R 1924	1M1 5% 0,25W	5322 111	44178
R 1925	22K6 1% 0,4W	5322 116	50481
R 1926	10K 1% 1% 0,4W	4822 116	51253
R 1927	27K4 1% 0,4W	5322 116	50559
R 1928	2K74 1% 0,4W	5322 116	50636
R 1929	2K74 1% 0,4W	5322 116	50636
R 1930	27K4 1% 0,4W	5322 116	50559

5.5.3. Capacitors

POSNR	DESCRIPTION	ORDERING CODE
C 100	33NF 10%	400V 5322 121 44025
C 101	100PF 1%	630V 4822 121 50562
C 102	100PF 1%	630V 4822 121 50562
C 103	5,5PF	400V 5322 125 54027
C 104	33PF 2%	100V 5322 122 31574
C 105	3,9PF	100V 5322 122 34162
C 106	2/30PF	250V 4822 125 50088
C 107	1NF 1%	630V 4822 121 50591
C 108	18PF 2%	100V 5322 122 34064
C 109	5/105PF	250V 5322 125 54082
C 110	11NF 1%	63V 5322 121 54147
C 111	82PF 2%	100V 4822 122 31237
C 112	150PF 2%	63V 4822 122 31308
C 113	270PF 2%	100V 4822 122 31168
C 115	100NF 10%	100V 5322 121 40323
C 116	10NF 80%	40V 4822 122 30043
C 151	22NF 80%	40V 4822 122 30103
C 152	22NF 80%	40V 4822 122 30103
C 153	22NF 80%	40V 4822 122 30103
C 201	33NF 10%	400V 5322 121 44025
C 202	33PF 2%	100V 5322 122 34139
C 203	22NF 80%	40V 4822 122 30103
C 204	220PF 2%	100V 4822 122 31173
C 205	10NF 50%	100V 4822 122 31414
C 251	22NF 80%	40V 4822 122 30103
C 253	22NF 80%	63V 4822 122 30103
C 301	22UF 20%	10V 4822 124 20943
C 302	1UF 10%	100V 5322 121 40197
C 303	15UF 20%	10V 5322 124 14036
C 304	47PF 2%	100V 4822 122 31072
C 305	470NF 20%	40V 5322 124 14123
C 306	680NF 10%	100V 5322 121 40233
C 307	22NF 80%	40V 4822 122 30103
C 308	22NF 80%	40V 4822 122 30103
C 309	22NF 80%	40V 4822 122 30103
C 311	22NF 80%	40V 4822 122 30103
C 312	3,3UF 20%	16V 4822 124 20947
C 351	22NF 80%	40V 4822 122 30103
C 352	22NF 80%	40V 4822 122 30103
C 401	22NF 10%	400V 5322 121 40308
C 402	1UF 20%	25V 4822 124 20944
C 403	1NF 10%	100V 4822 122 31175
C 404	4,7NF 10%	100V 4822 122 30128
C 405	33NF 10%	400V 5322 121 44025
C 406	1NF 10%	630V 5322 121 44286
C 407	22NF 80%	40V 4822 122 30103
C 408	22NF 80%	40V 4822 122 30103
C 409	22NF 80%	40V 4822 122 30103
C 410	22NF 80%	40V 4822 122 30103
C 411	22NF 80%	40V 4822 122 30103
C 501	56PF 2%	100V 4822 122 31074
C 502	100PF 2%	100V 4822 122 31081
C 503	22NF 80%	40V 4822 122 30103
C 504	22NF 80%	40V 4822 122 30103
C 505	22PF 5%	100V 4822 122 31063
C 506	22NF 80%	40V 4822 122 30103
C 507	22NF 80%	40V 4822 122 30103
C 508	100PF 2%	100V 4822 122 31504
C 509	100PF 2%	100V 4822 122 31316
C 601	4.7NF 10%	630V 5322 121 44225
C 602	220NF 10%	100V 4822 121 40232
C 603	22NF 10%	400V 5322 121 40308

POSNR	DESCRIPTION	ORDERING CODE
C 604	22NF 80% 40V	4822 122 30103
C 605	470PF 2% 100V	5322 122 34159
C 606	680NF 10% 100V	5322 121 40233
C 607	470PF 2% 100V	5322 122 34159
C 608	47PF 2% 100V	4822 122 31072
C 609	10NF 50% 100V	4822 122 31414
C 610	10NF 50% 100V	4822 122 31414
C 611	10NF 50% 100V	4822 122 31414
C 612	22NF 80% 40V	4822 122 30103
C 613	22NF 80% 40V	4822 122 30103
C 614	22NF 80% 40V	4822 122 30103
C 615	22NF 80% 40V	4822 122 30103
C 616	1NF 10% 630V	5322 121 44286
C 651	22NF 80% 40V	4822 122 30103
C 652	22NF 80% 40V	4822 122 30103
C 653	10NF 50% 100V	4822 122 31414
C 654	100PF 2% 100V	4822 122 31504
C 655	22NF 80% 40V	4822 122 30103
C 801	3300UF 50% 10V	4822 124 20772
C 802	330UF 50% 10V	4822 124 20684
C 803	470UF 50% 25V	4822 124 20784
C 804	470UF 50% 25V	4822 124 20784
C 806	2,2UF 20% 16V	4822 124 10204
C 807	2,2UF 20% 16V	4822 124 10204
C 808	22UF 20% 10V	4822 124 20943
C 809	100PF 2% 100V	4822 122 31081
C 1901	22NF 80% 40V	4822 122 30103
C 1902	1NF 10% 100V	4822 122 30027
C 1903	100PF 2% 100V	4822 122 31504
C 1904	22NF 80% 40V	4822 122 30103
C 1905	22NF 80% 40V	4822 122 30103
C 1906	22NF 80% 40V	4822 122 30103
C 1907	22PF 2% 100V	5322 122 34067
C 1908	47PF 2% 100V	4822 122 31244
C 1909	22NF 80% 40V	4822 122 30103
C 1910	22PF 2% 100V	5322 122 34067
C 1911	22PF 2% 100V	5322 122 34067
C 1912	1NF 10% 100V	4822 122 30027
C 1913	22NF 80% 40V	4822 122 30103
C 1914	22NF 80% 40V	4822 122 30103
C 1915	1UF 20% 25V	4822 124 20944
C 1916	22NF 80% 40V	4822 122 30103
C 1917	22NF 80% 40V	4822 122 30103
C 1918	1NF 10% 100V	4822 122 30027
C 1919	22NF 80% 40V	4822 122 30103
C 1920	22NF 80% 40V	4822 122 30103
C 1921	10NF 80% 40V	4822 122 30043
C 1922	10NF 80% 40V	4822 122 30043
C 1923	10NF 80% 40V	4822 122 30043
C 1924	10NF 80% 40V	4822 122 30043
C 1925	10NF 80% 40V	4822 122 30043
C 1926	10NF 80% 40V	4822 122 30043
C 1927	10NF 80% 40V	4822 122 30043
C 1928	10NF 80% 40V	4822 122 30043
C 1929	10NF 80% 40V	4822 122 30043
C 1930	10NF 80% 40V	4822 122 30043
C 1931	10NF 80% 40V	4822 122 30043
C 1932	10NF 80% 40V	4822 122 30043

5.5.4. Semi conductors

POSNR	DESCRIPTION	ORDERING CODE
V 151	BAW62	4822 130 30613
V 152	BAW62	4822 130 30613
V 153	BAW62	4822 130 30613
V 201	BF256B	5322 130 44744
V 202	BF256B	5322 130 44744
V 203	BC 547B	4822 130 40959
V 204	BC558	4822 130 40941
V 205	BC558	4822 130 40941
V 206	BC 547B	4822 130 40959
V 207	BC558	4822 130 40941
V 208	BC 547B	4822 130 40959
V 209	BC 547B	4822 130 40959
V 210	BC558	4822 130 40941
V 251	BY527	4822 130 31509
V 252	BY527	4822 130 31509
V 253	BZX70-C7V5	5322 130 34981
V 254	BZX70-C7V5	5322 130 34981
V 257	BZX70-C12	5322 130 30753
V 258	BZX70-C12	5322 130 30753
V 259	BAW62	4822 130 30613
V 260	BAW62	4822 130 30613
V 261	BAW62	4822 130 30613
V 263	BAW62	4822 130 30613
V 264	0A 95	4822 130 30191
V 265	0A 95	4822 130 30191
V 301	BF256A	5322 130 44418
V 302	ON528	5322 130 44405
V 303	BC 547B	4822 130 40959
V 304	BC 547B	4822 130 40959
V 305	BF324	4822 130 41448
V 306	BC 547B	4822 130 40959
V 350	BC558	4822 130 40941
V 351	BAW62	4822 130 30613
V 401	BF256A	5322 130 44418
V 403	BC 547B	4822 130 40959
V 450	BZX70-C10	5322 130 34299
V 451	BZX70-C10	5322 130 34299
V 452	BZX79-B13	4822 130 34195
V 453	BAW62	4822 130 30613
V 454	BZV46-C2V0	4822 130 31248
V 501	BF324	4822 130 41448
V 502	BSX20	5322 130 40417

POSNR	DESCRIPTION	ORDERING CODE
V 503	BSX20	5322 130 40417
V 504	BF324	4822 130 41448
V 505	BF324	4822 130 41448
V 506	BC 547B	4822 130 40959
V 507	BC 547B	4822 130 40959
V 550	BAW62	4822 130 30613
V 551	BAW62	4822 130 30613
V 601	BC 547B	4822 130 40959
V 602	BC 547B	4822 130 40959
V 603	BF256A	5322 130 44418
V 604	BF256A	5322 130 44418
V 605	ON528	5322 130 44405
V 606	ON528	5322 130 44405
V 607	ON528	5322 130 44405
V 608	ON 527	5322 130 44528
V 609	BC 547B	4822 130 40959
V 610	BC 547B	4822 130 40959
V 611	BC 547B	4822 130 40959
V 612	BC 547B	4822 130 40959
V 613	BC 547B	4822 130 40959
V 614	BFW12	5322 130 41785
V 652	BAW62	4822 130 30613
V 654	BZX79-B7V5	4822 130 30861
V 655	BZV46-C1V5	5322 130 34865
V 656	BZV46-C1V5	5322 130 34865
V 657	BZV46C2V0	4822 130 31248
V 801	BC 547B	4822 130 40959
V 802	BC 547B	4822 130 40959
V 803	BD675	5322 130 44786
V 804	BC558	4822 130 40941
V 805	BZX79-B9V1	4822 130 30862
V 851	BY164	4822 130 30414
V 852	BZX79-B5V1	4822 130 34233
V 853	BY164	4822 130 30414
V 855	BZX79-B5V1	4822 130 34233
V 1901	OA95	4822 130 30191

5.5.5. Integrated circuit

POSNR	DESCRIPTION	ORDERING CODE
A 201	UA714HC	5322 209 86169
A 302	OQ0061	5322 209 85885
A 401	OQ0063	5322 209 80989
A 501	UA741TC	4822 209 80617
A 502	UA710HC	5322 209 86414
A 601	UA741TC	4822 209 80617
A 602	OQ0064	5322 209 85887
A 603	OQ0060	5322 209 85884
A 801	LM78L05ACZ	5322 209 80903
A 802	UA741TC	4822 209 80617
D 1901	N74LS244N	5322 209 86017
D 1902	SN74LS161AN	5322 209 85915
D 1903	HEF4027BP	5322 209 14055
D 1904	P8035	5322 209 86479
D 1905	HEF40174BP	5322 209 14444
D 1906	HEF40174BP	5322 209 14444
D 1907	SN74LS161AN	5322 209 85915
D 1908	SAA1060	4822 209 80512
D 1909	2716	5322 209 54696
D 1910	HEF4070BP	5322 209 14073
D 1911	SN74LS86N	5322 209 84997
D 1912	HEF40174BP	5322 209 14444
D 1913	SN74LS10N	5322 209 84996
D 1914	HEF4011BP	5322 209 14046
D 1915	SN74LS74	4822 209 80782
D 1916	HEF4051P	5322 209 14212
D 1917	HEF40106BP	5322 209 14549
D 1918	HEF4023BP	5322 209 14065
D 1919	HEF4051P	5322 209 14212
D 1920	2716	5322 209 54697
D 1921	N74LS00N	5322 209 84823

6. CIRCUIT DIAGRAMS AND P.C.B. LAY-OUTS

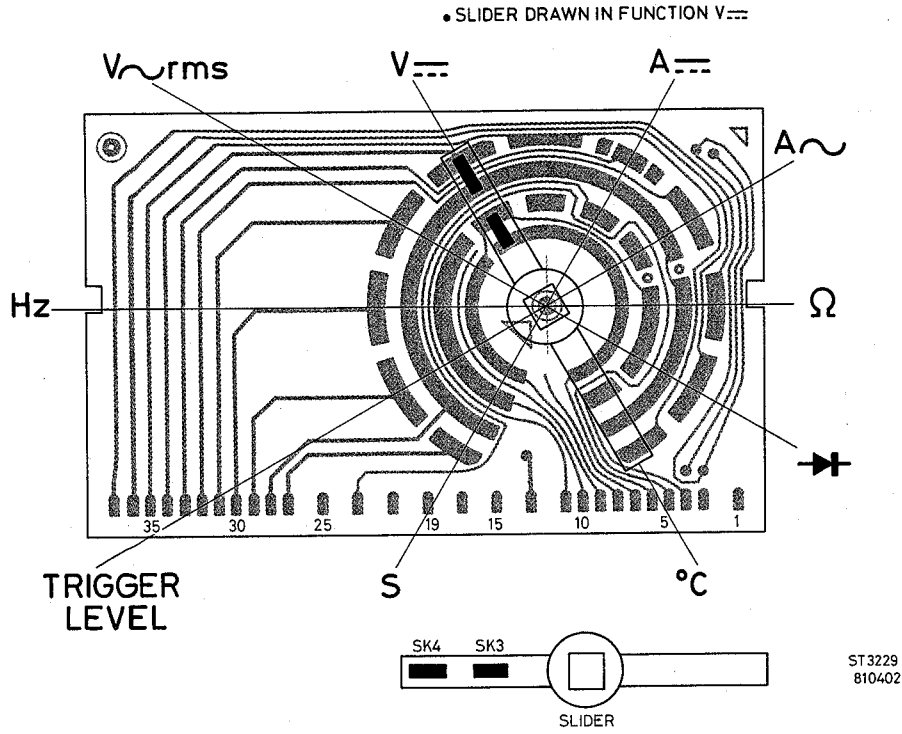

Fig. 54. Switch p.c.b. lay-out, front view

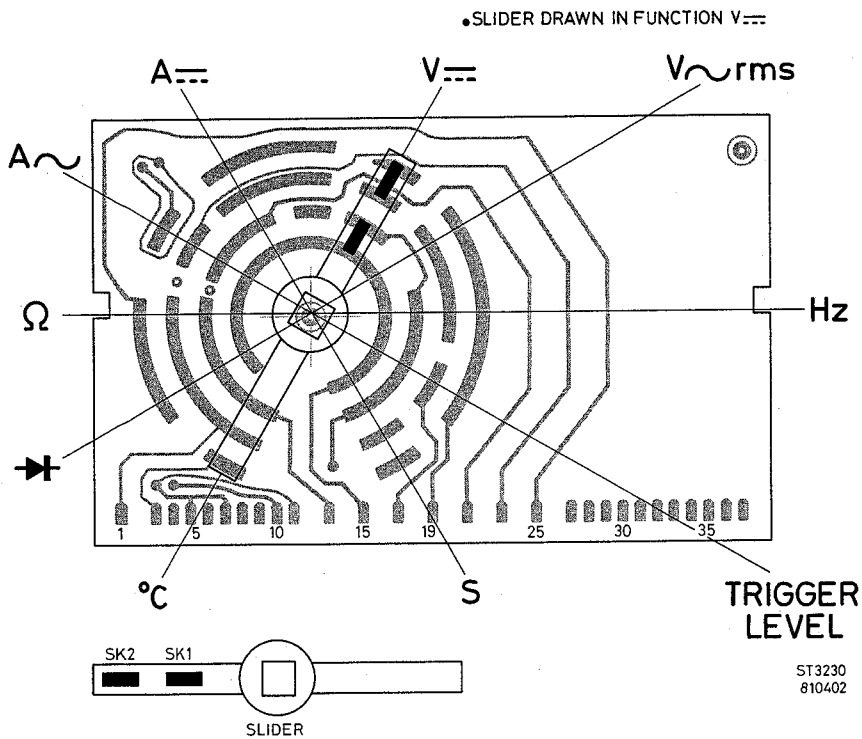
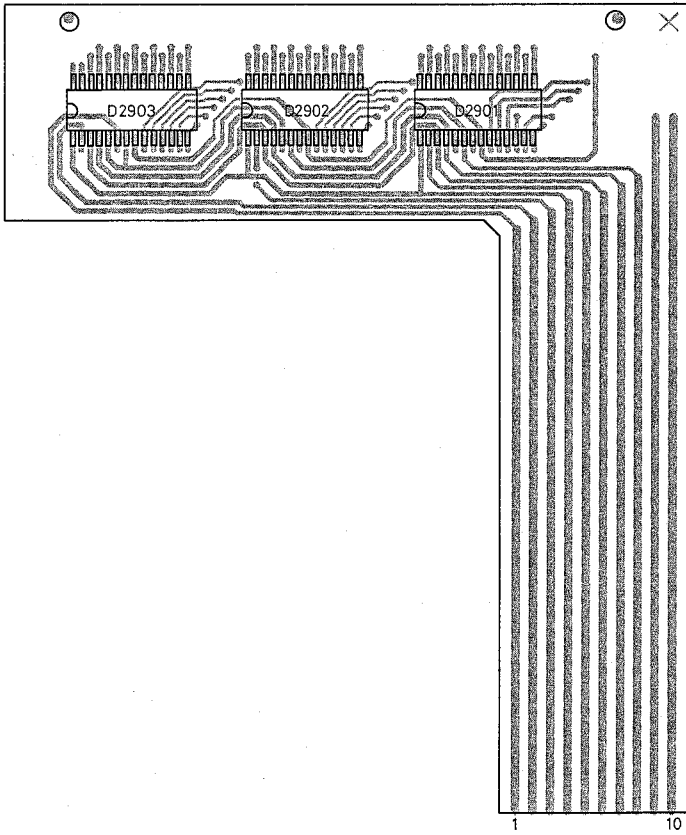
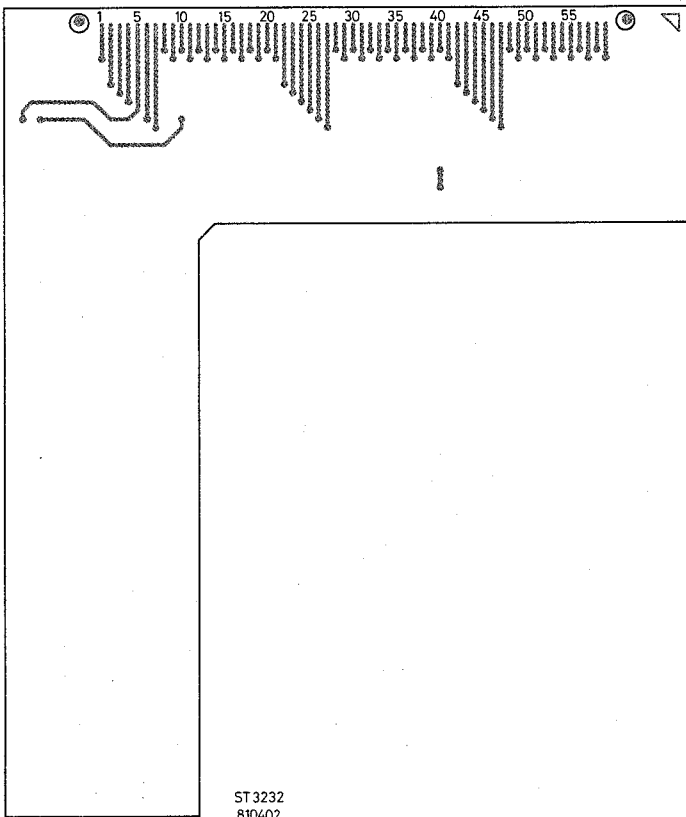

Fig. 55. Switch p.c.b. lay-out, rear view



ST3231
810402

Fig. 56. Display p.c.b. lay-out, component side



ST3232
810402

Fig. 57. Display p.c.b. lay-out, conductor side

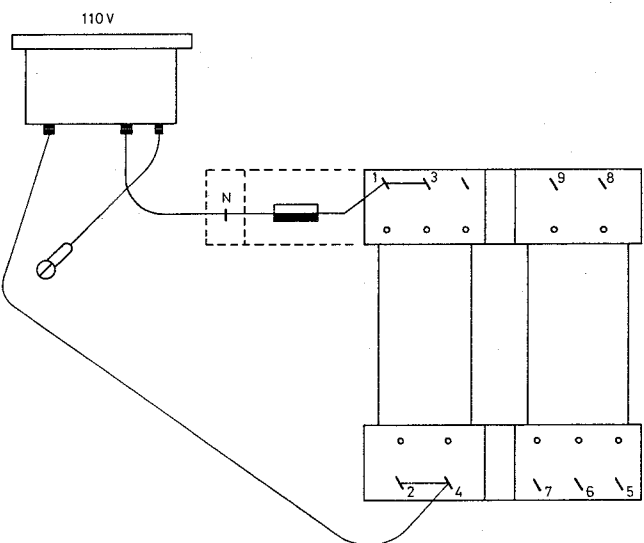
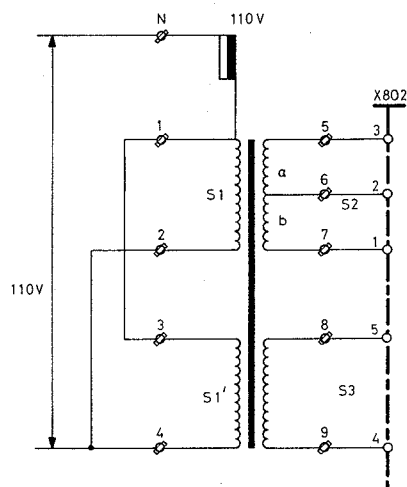
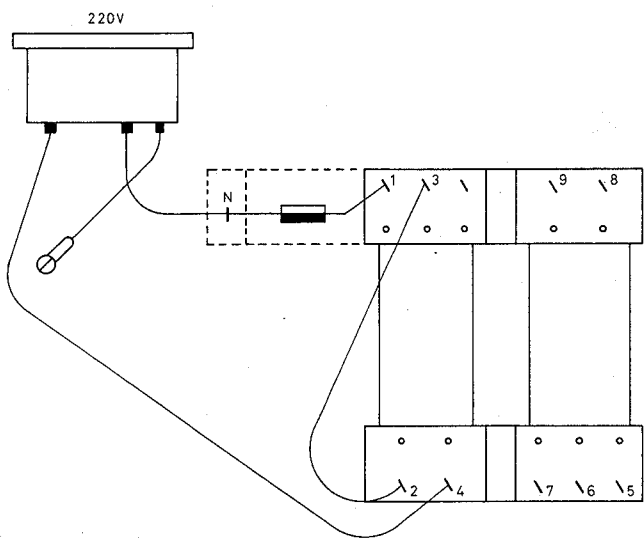
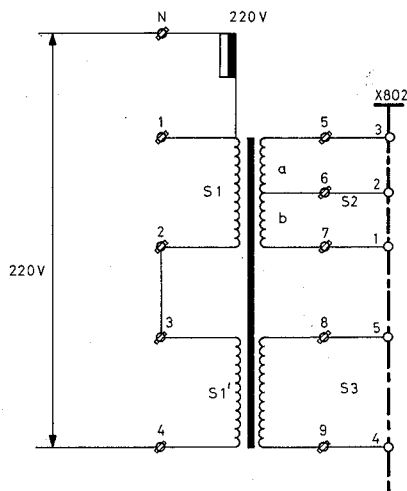
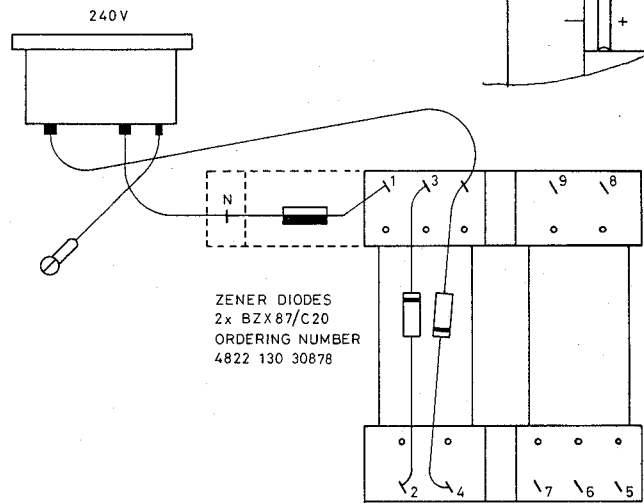
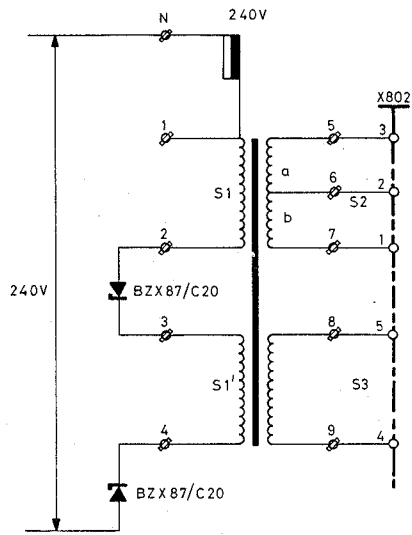
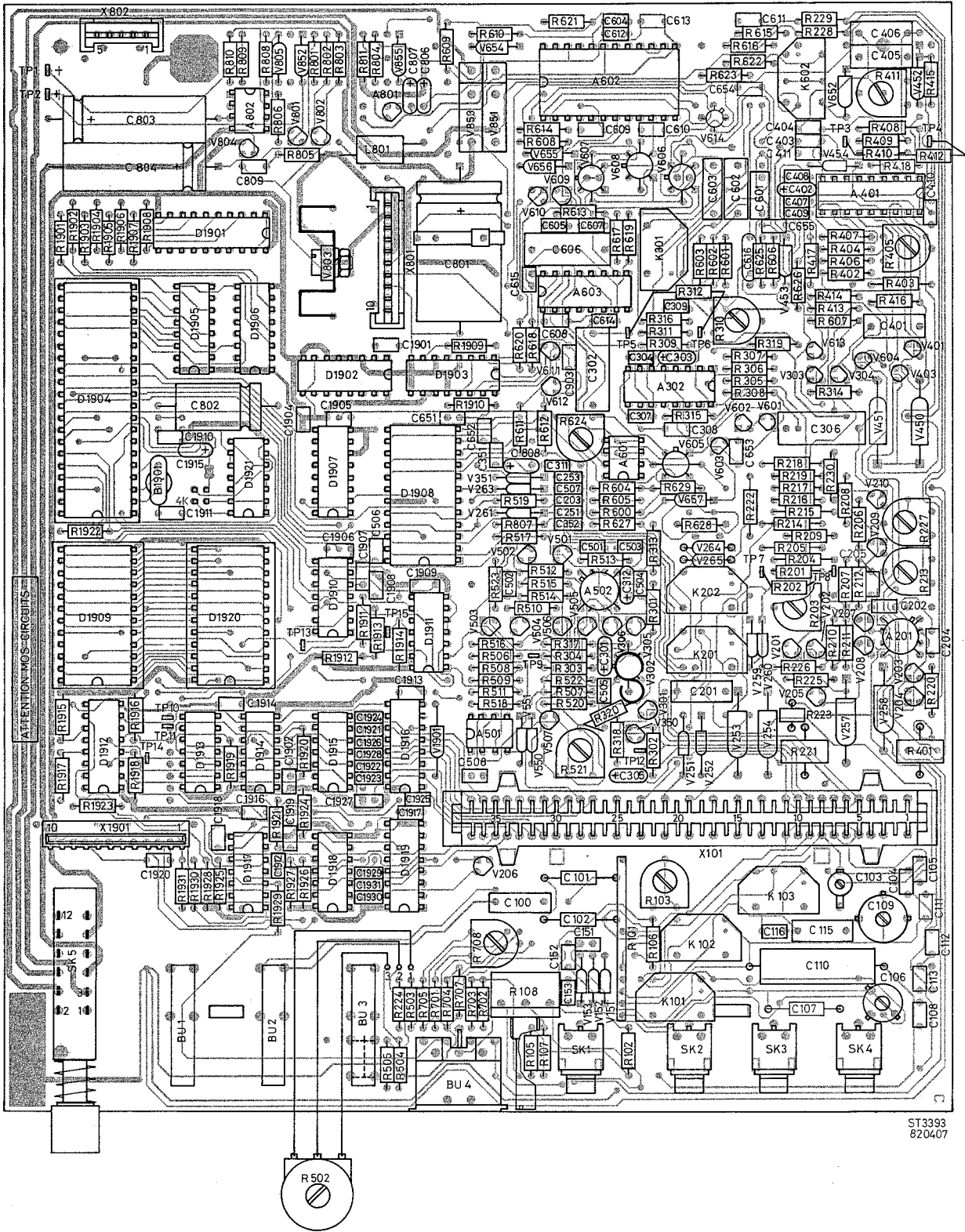

Fig. 58. Adapting the mains transformer



ST3393
820407

Fig. 59. Main p.c.b. lay-out, component side

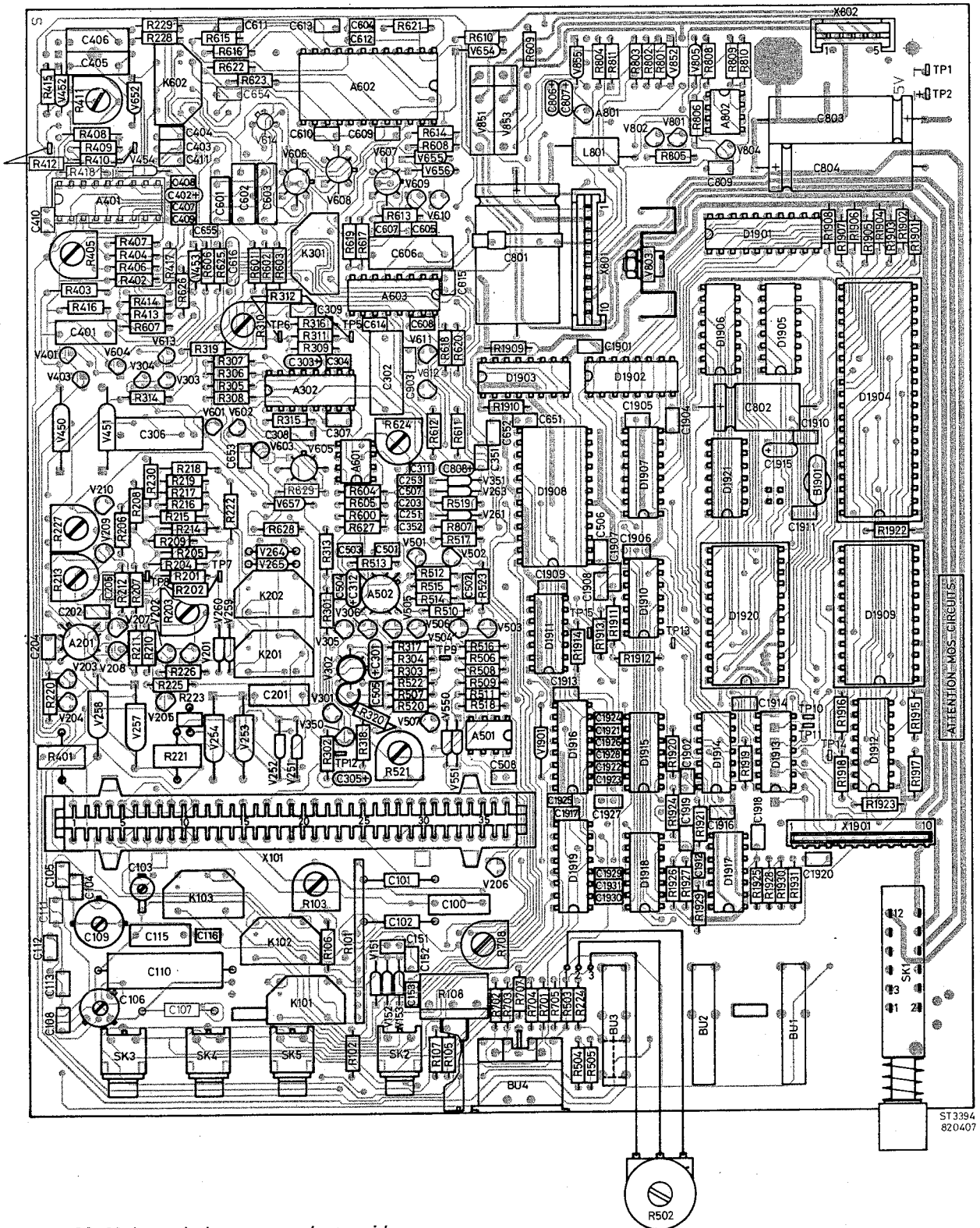

Fig. 60. Main p.c.b. lay-out, conductor side

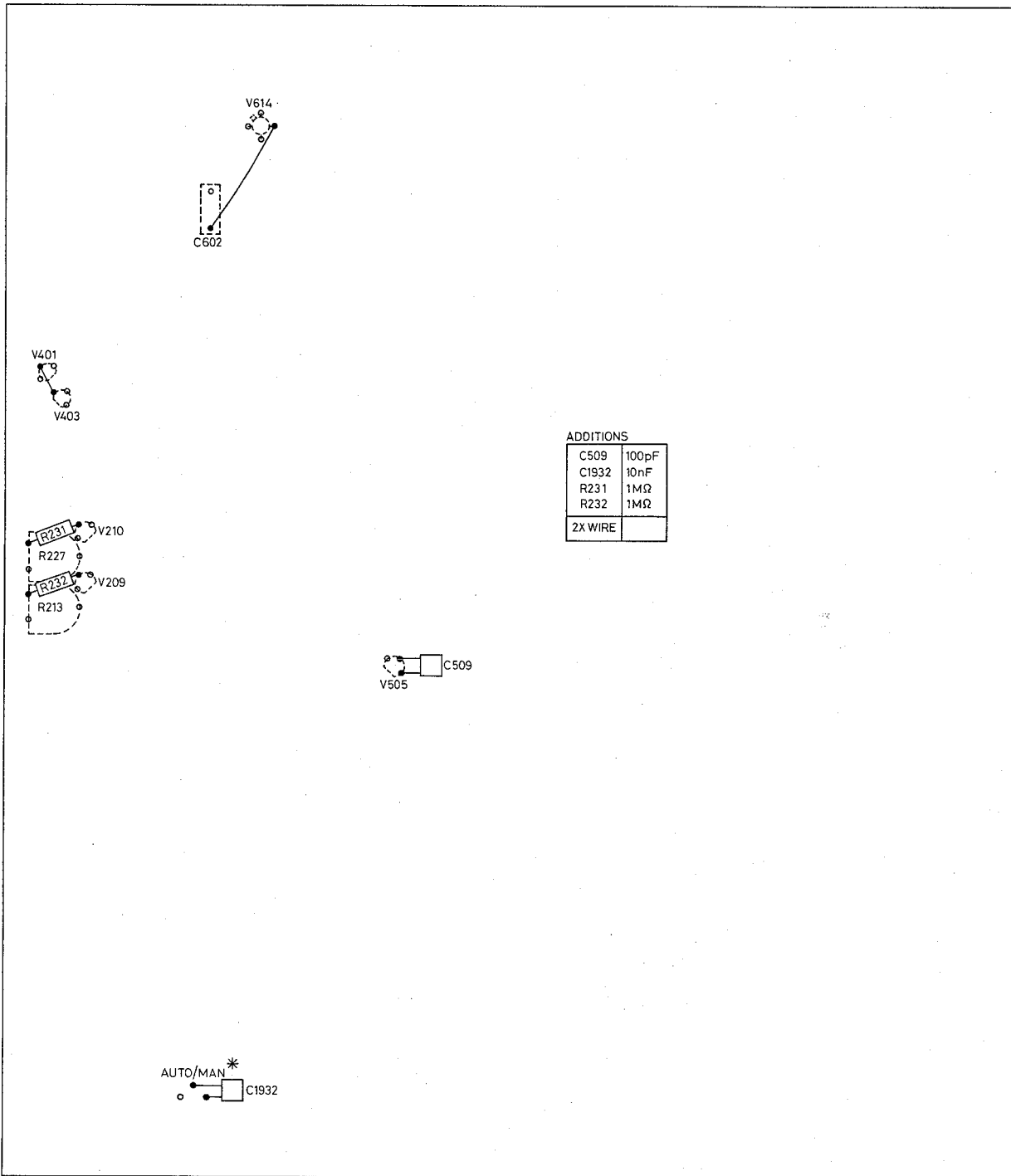

Fig. 61. Additional components conductor side of main p.c.b.

ST3444
820208

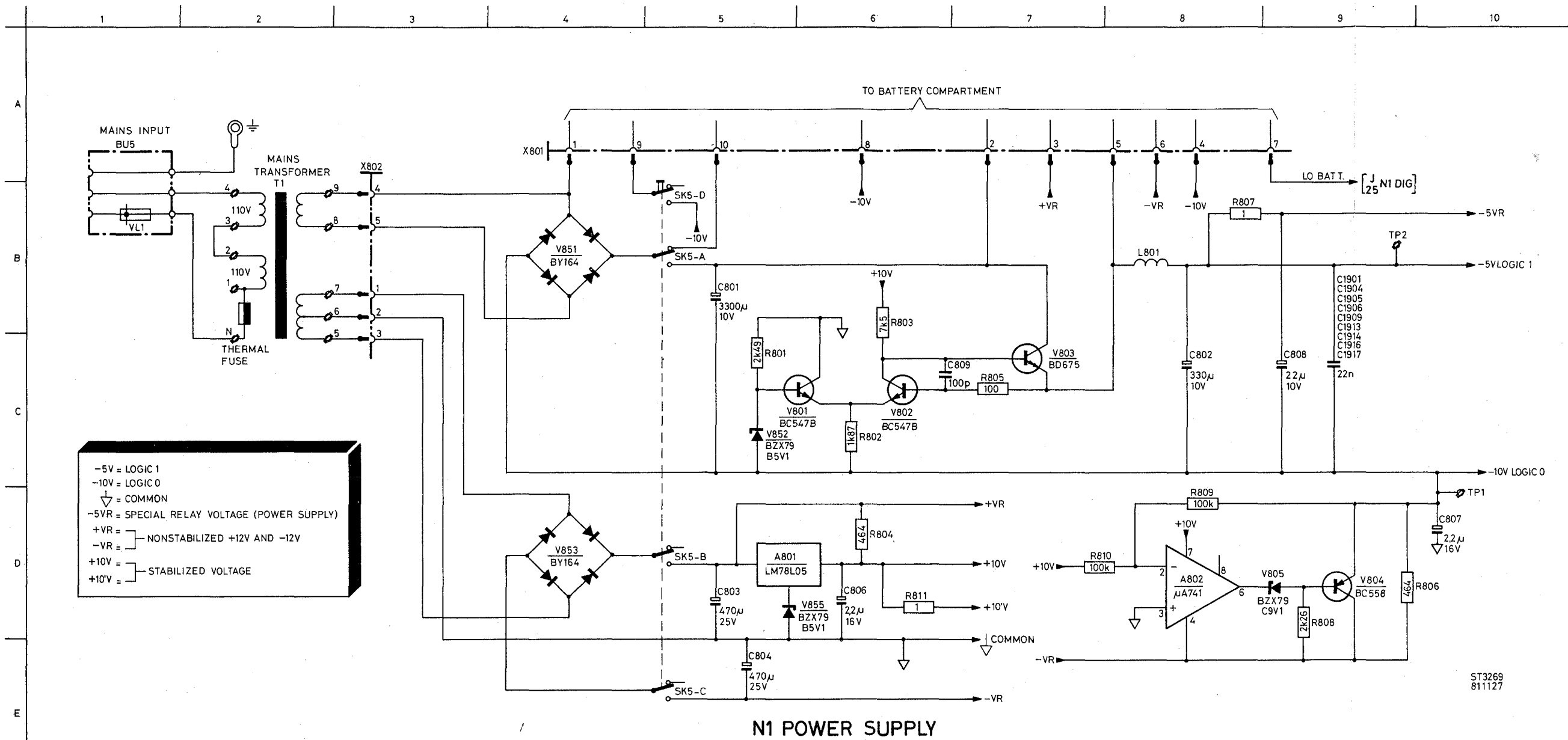

Fig. 62. Power supply circuit diagram

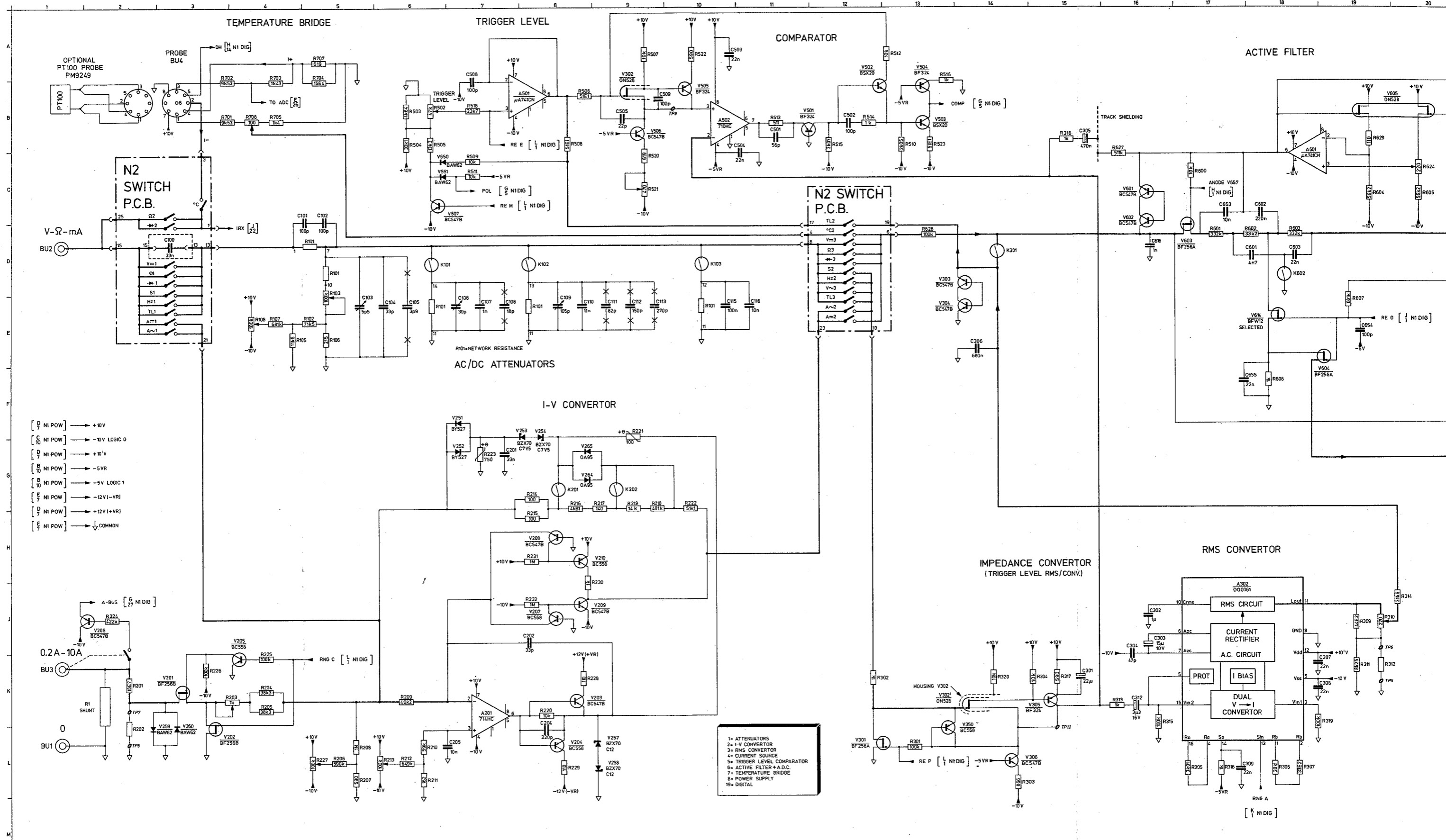
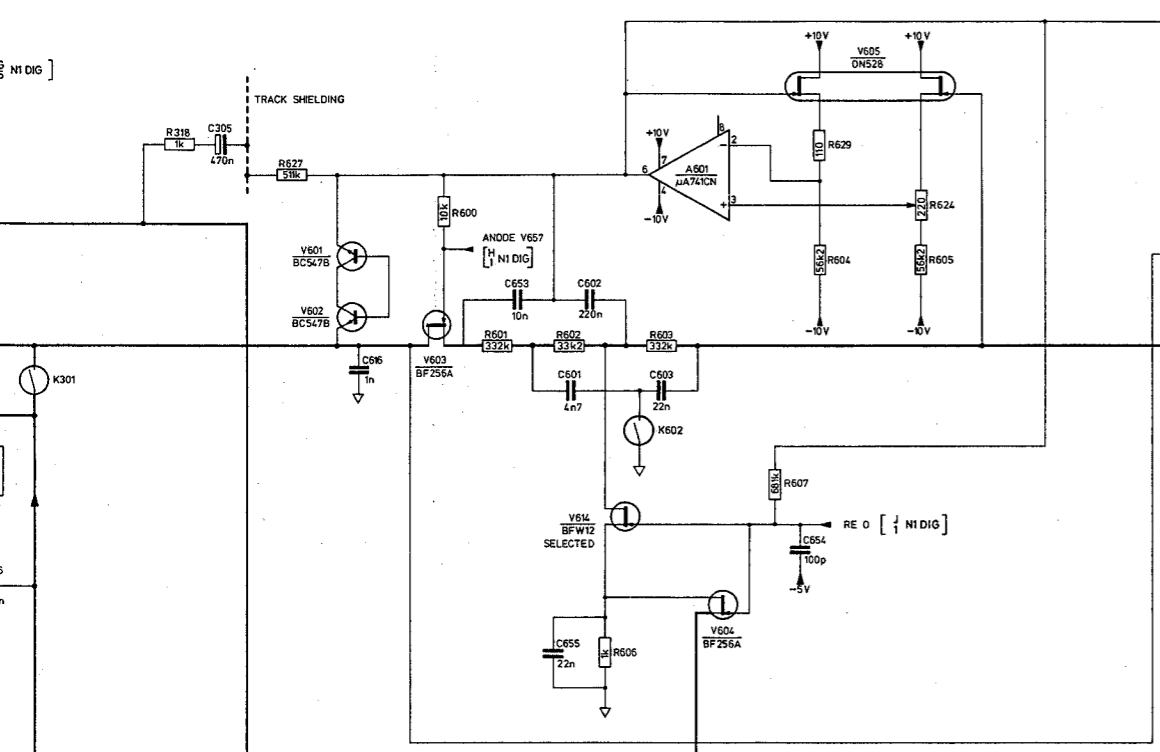
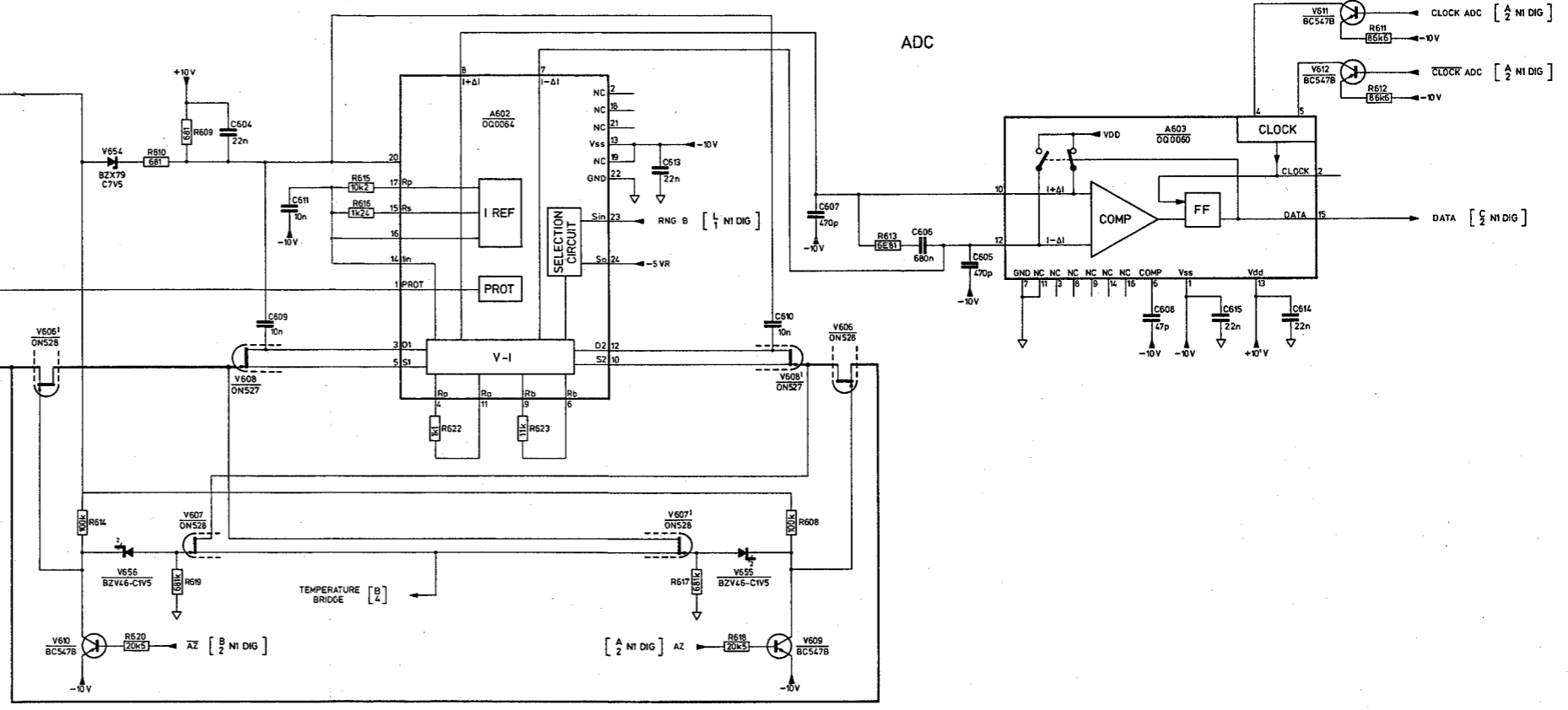

Fig. 63. Analog section diagram

ACTIVE FILTER



ADC



IMPEDANCE CONVERTOR (TRIGGER LEVEL RMS/CONV)

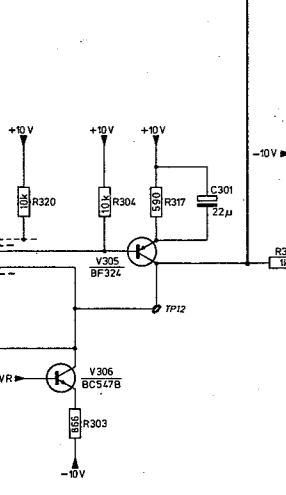

RMS CONVERTOR

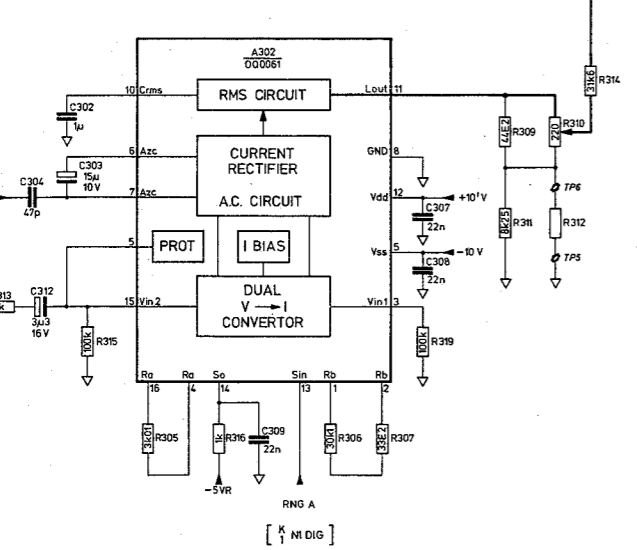

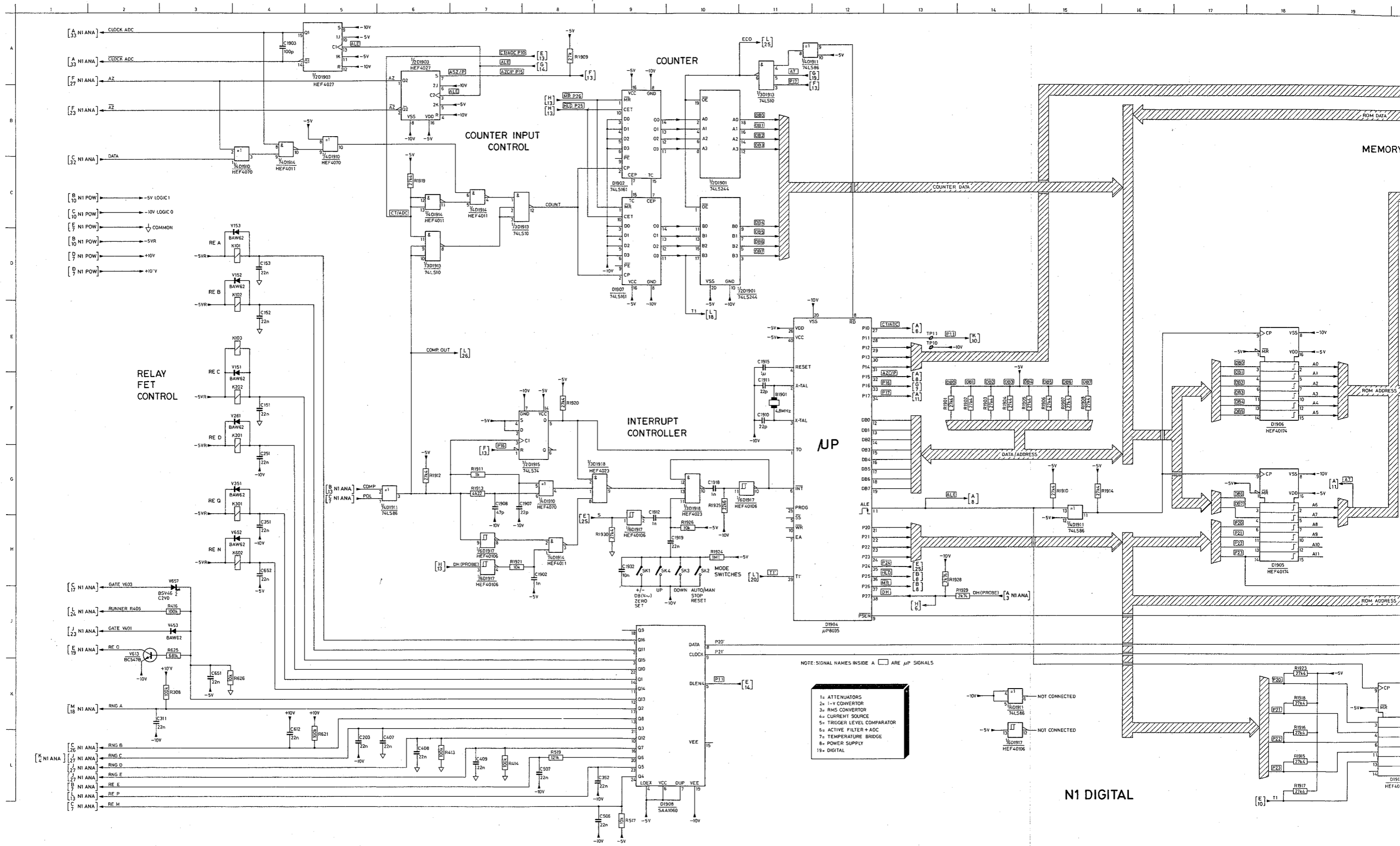

NOTE: SIGNAL NAMES INSIDE A ARE µP SIGNALS

- 1= ATTENUATORS
- 2= 1-V CONVERTOR
- 3= RMS CONVERTOR
- 4= CURRENT SOURCE
- 5= TRIGGER LEVEL COMPARATOR
- 6= ACTIVE FILTER + ADC
- 7= TEMPERATURE BRIDGE
- 8= POWER SUPPLY
- 9= DIGITAL

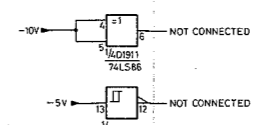

N1 DIGITAL

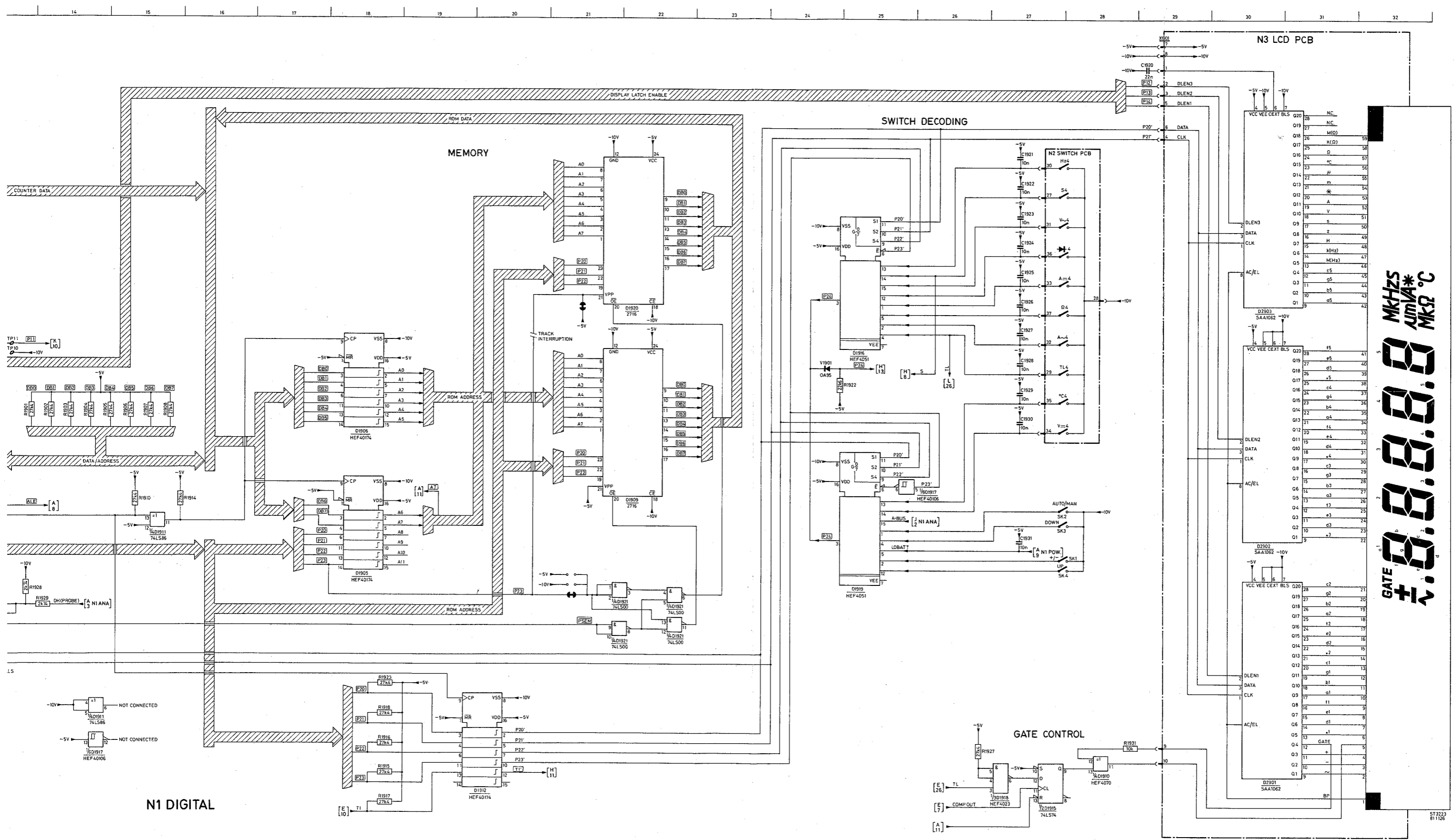

GATE
 0.0.0.0.0.0.0.0.0.0
 MKHZS
 AUMVA*
 MKΩ °C

Fig. 64. Digital section circuit diagram

7. MODIFICATIONS TO THE PM2521

This service manual is based on the instrument numbers DM 01 1145 and onwards. For instruments with a lower number the following modifications are given.

7.1. Modifications to circuit diagrams and p.c.b. lay-out.

The following diagrams must be used:

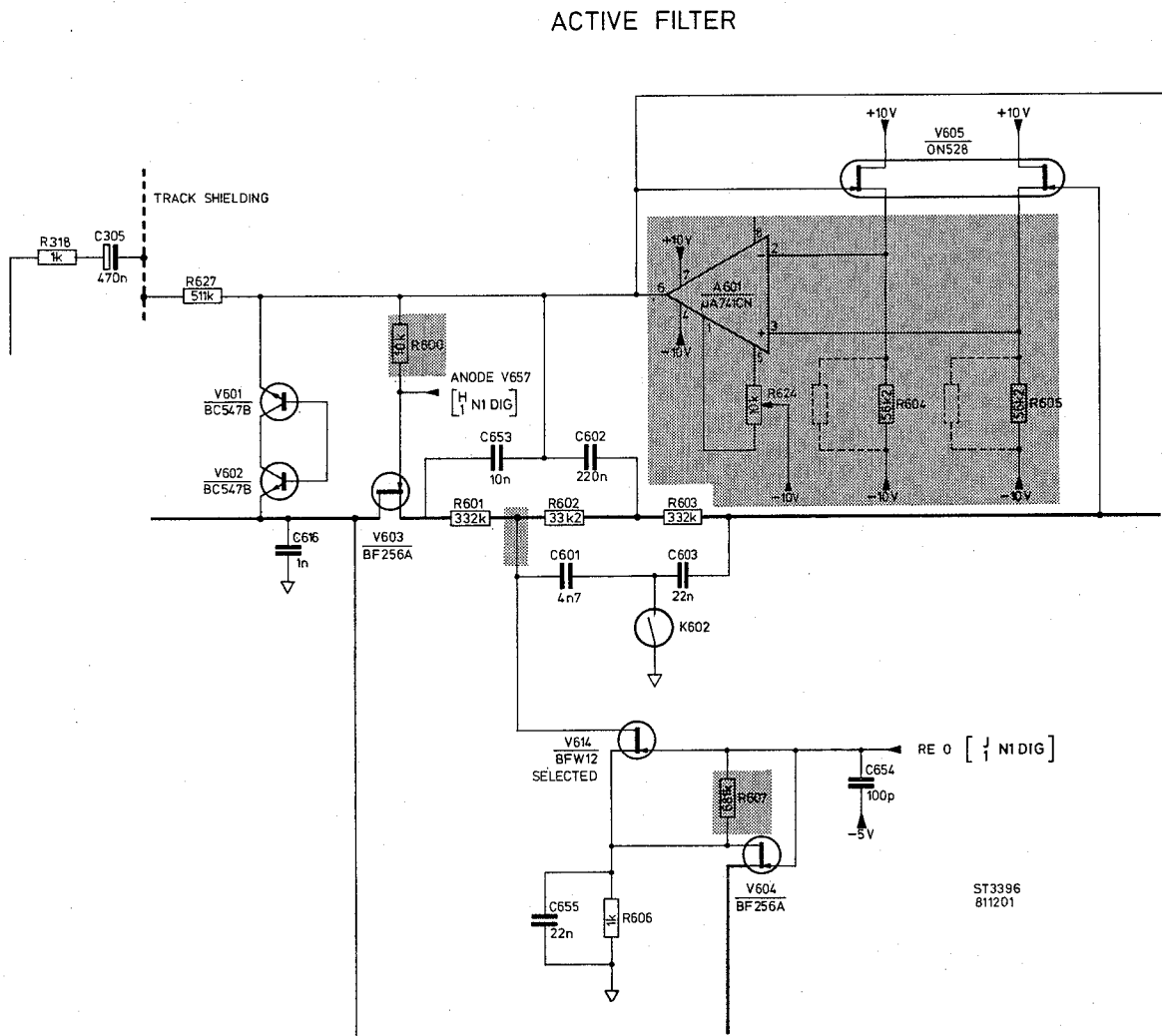
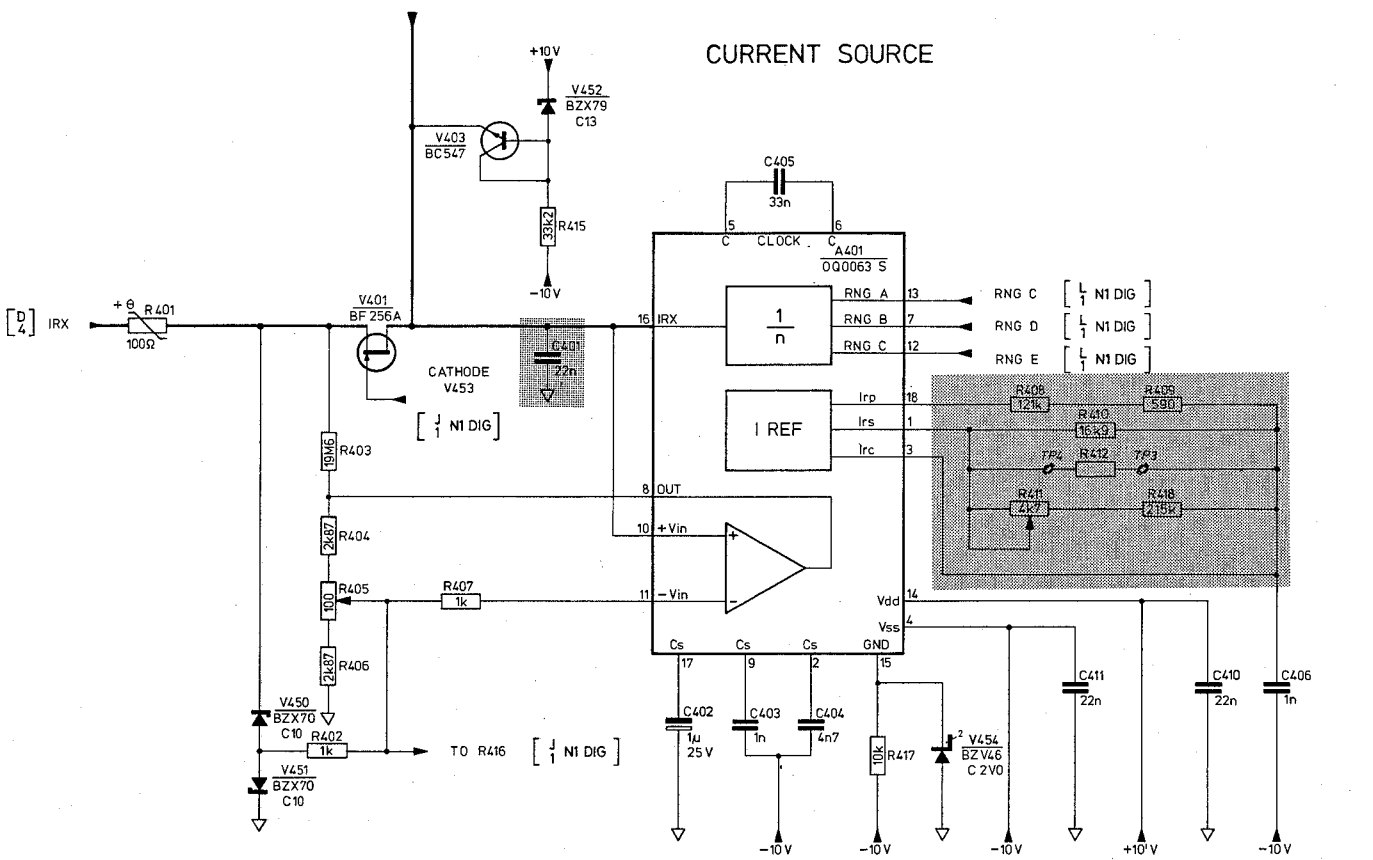
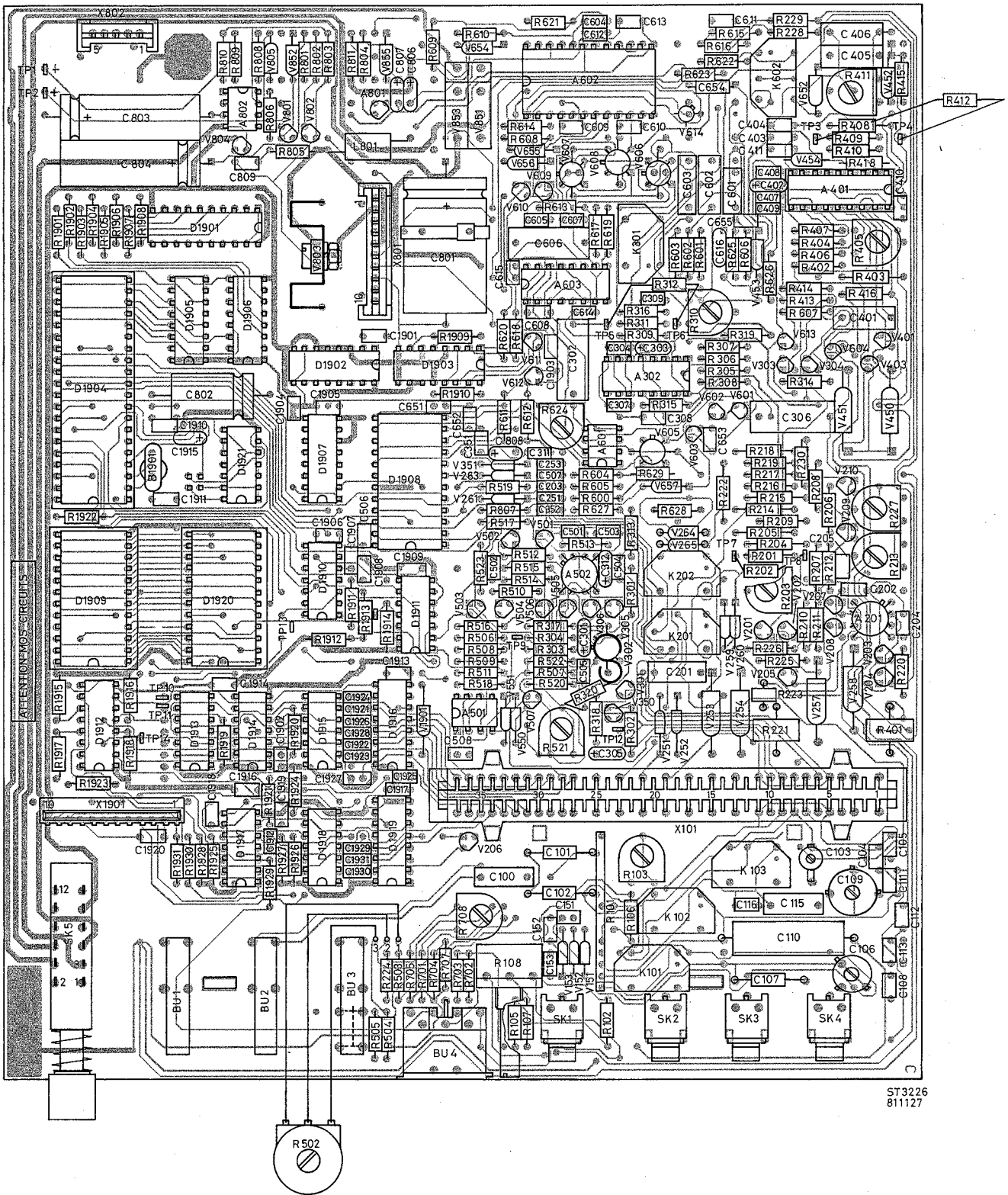

Fig. 65. Modifications to active filter



ST3397
81 11 30

Fig. 66. Modifications to current source



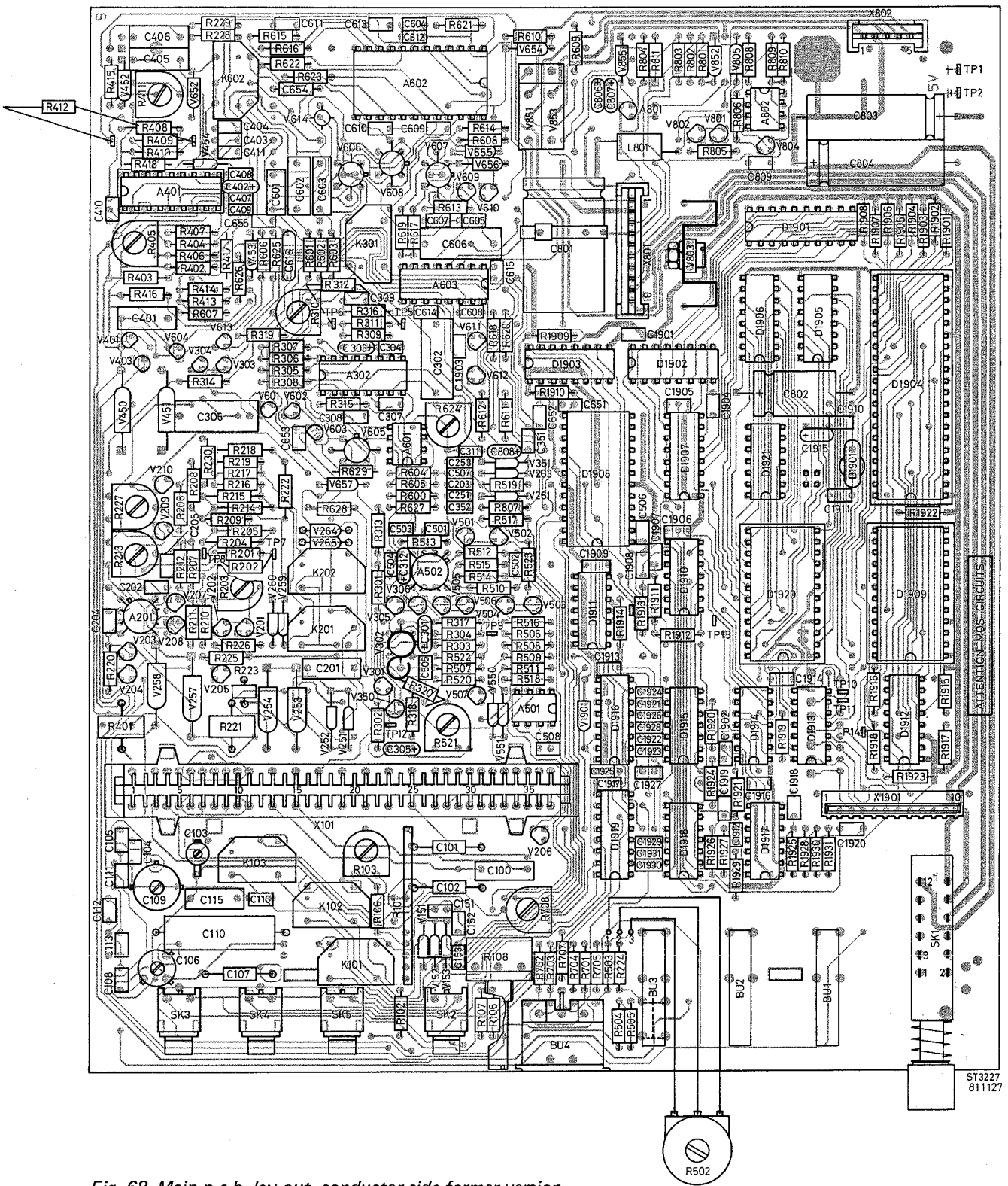

Fig. 68. Main p.c.b. lay-out, conductor side former version

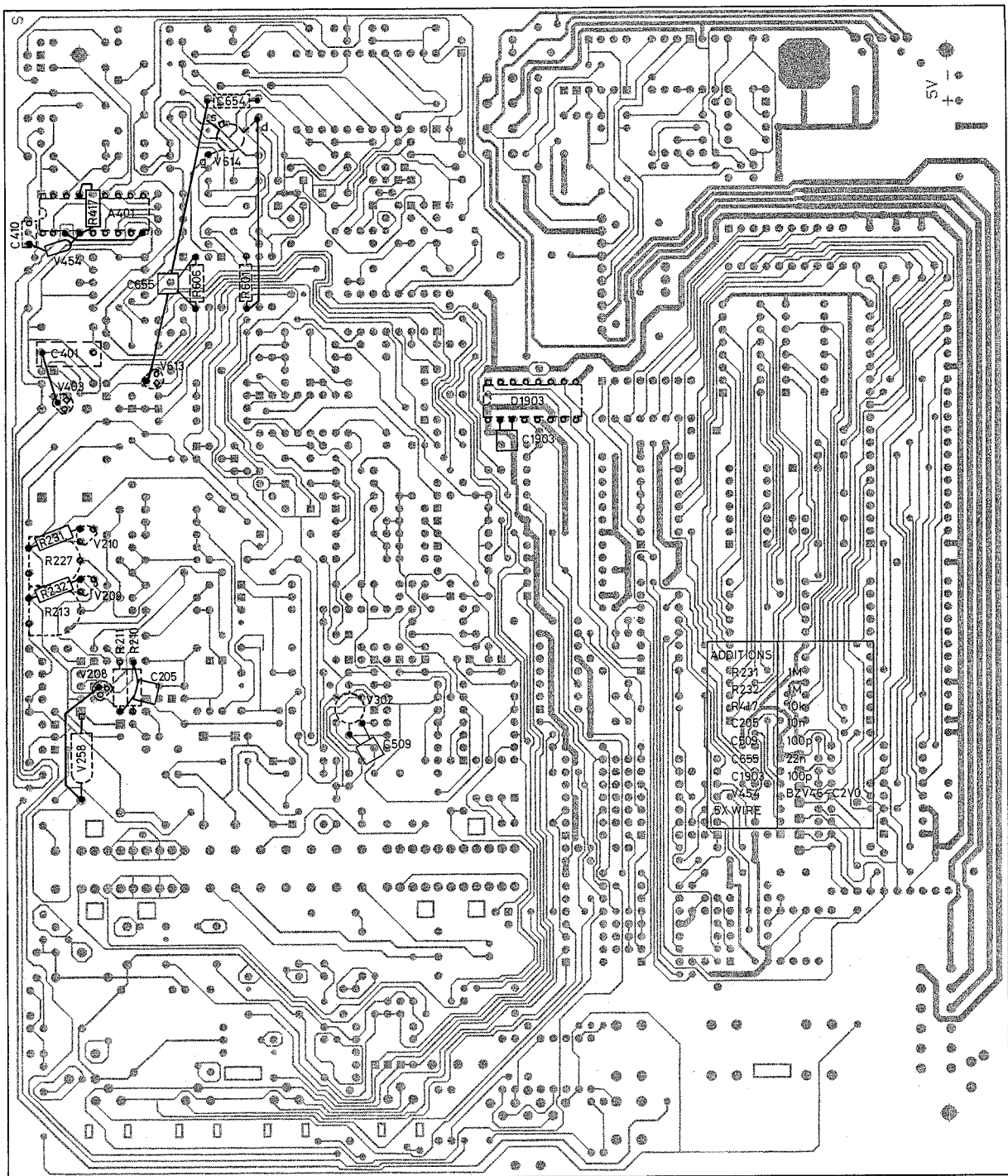

Fig. 69. Additional components on conductor side of main p.c.b.

ST 3243
811127

7.2. MODIFICATION TO COMPONENTS

DM 01 635 upto DM 01 1145

From DM 01 11145 onwards

R600	56k2	(5322 116 54676)	10k	(5322 116 54619)
R624	10k potm.	(4822 100 10035)	220 Ω potm.	(4822 100 10019)
R629	—	—	110 Ω	(5322 116 54474)
R626	68k1	(5322 116 54683)	10k	(5322 116 54619)
R411	4k7 potm.	(4822 100 10036)	47k potm.	(4822 100 10079)
R418	—	—	215k	(5322 116 54728)
R304	5k9	(5322 116 50583)	10k	(5322 116 54619)
R317	1k27	(5322 116 50555)	590 Ω	(5322 116 50561)
R507	5k9	(5322 116 50583)	10k	(5322 116 54619)
R522	1k27	(5322 116 50555)	590 Ω	(5322 116 50561)
R707	887 Ω or 619 Ω (887 = 5322 116 54544)		619 Ω	(5322 116 54529)
R622	1k21 or 1k1 (1k21 = 5322 116 54554)		1k1	(5322 116 54554)
R623	12k1 or 11k0 (12k1 = 5322 116 50572)		11k0	(5322 116 54619)
R231	1M or no resistor placed (5322 116 55535)		1M	(5322 116 55535)
R232	1M or no resistor placed (5322 116 55535)		1M	(5322 116 55535)
V251	BYX10	(4822 130 30195)	BY527	(4822 130 31509)
V252	BYX10	(4822 130 30195)	BY527	(4822 130 31509)
V657	BAW62	(4822 130 30613)	BZV46 C2V0	(4822 130 31248)

7.3. MODIFICATIONS TO THE ADJUSTING PROCEDURE (refer to chapter 3.1).

Adjustment 1: Active filter.

If adjustment is not possible because the potentiometer R624 is turned fully anti-clockwise then solder a resistor of 1M Ω (MR 25,1% E48 series) in parallel across R604 and repeat adjustment 1.

If the potentiometer R624 is turned fully clockwise, then solder a resistor of 1M Ω (MR25,1% E48 series) in parallel across R605 and repeat adjustment 1.

8. COMPONENT DATA

8.1. SEMI CONDUCTORS

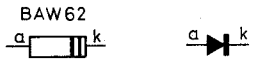
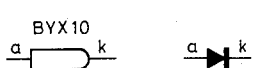
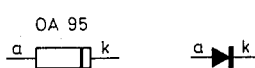
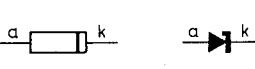
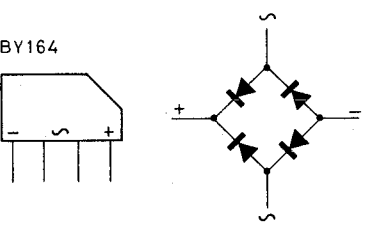
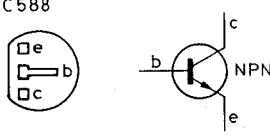
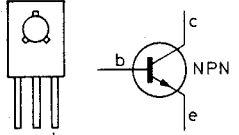
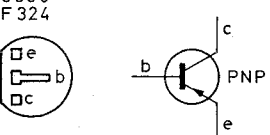
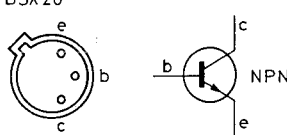
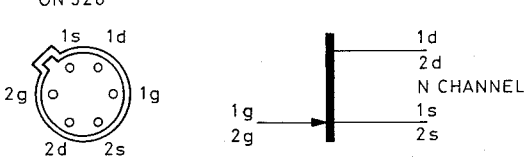
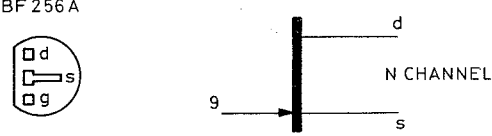
<p>BAW62</p> 	
<p>BYX10</p> 	<p>OA 95</p> 
<p>BZX70-C7V5 C12 C10 BZX79-B13 C7V5 C1V5 C9V1 B5V1 BZV46-C1V5 C2V0</p> 	
<p>BY164</p> 	
<p>BC547B BC588</p> 	<p>BD675</p> 
<p>BC558 BF324</p> 	<p>BSX20</p> 
<p>ON 528</p> 	
<p>BF 256B BF 256A</p> 	

ABSOLUTE MAXIMUM RATINGS 78L05ACS

PARAMETER	RATING	UNIT
Input voltage	30	V
Internal power dissipation	Internally limited	
Storage temperature range		
Metal can (TO-39 type)	-65 to +150	°C
Moulded TO-92	-55 to +150	°C
Operating junction temperature range	0 to +150	°C
Lead temperatures		
Metal can (soldering, 60s time limit)	300	°C
Moulded TO-92 (soldering, 10s time limit)	260	°C

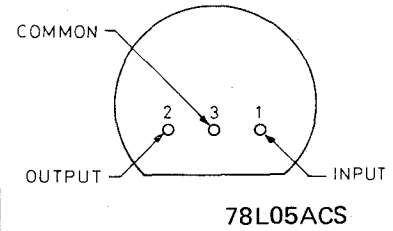

8.2. LOCOS CIRCUITS (HEF)

HEF4011B QUADRUPLE 2-INPUT NAND GATE

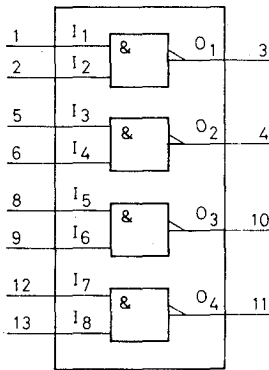

Functional diagram

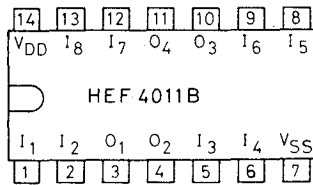

Pinning diagram

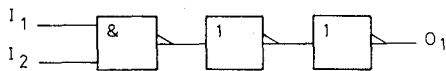

Logic diagram (one gate)

HEF4023B TRIPLE 3-INPUT NAND GATE

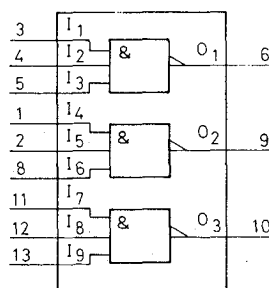

Functional diagram

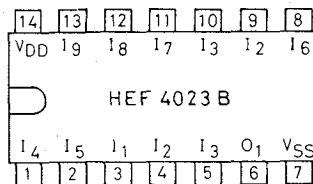

Pinning diagram

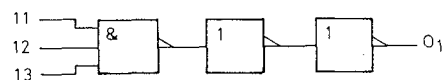

Logic diagram (one gate)

HEF4027B DUAL JK FLIP-FLOP

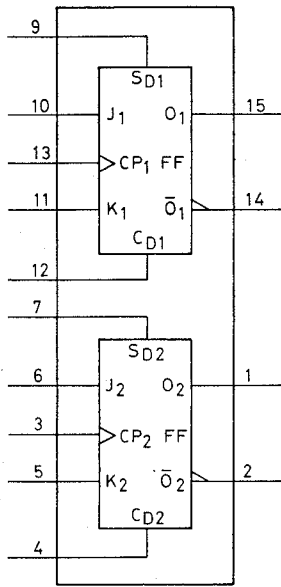

Functional diagram

FUNCTION TABLES

inputs					outputs	
S_D	C_D	CP	J	K	O	\bar{O}
H	L	X	X	X	H	L
L	H	X	X	X	L	H
H	H	X	X	X	H	H

inputs					outputs	
S_D	C_D	CP	J	K	$O_n + 1$	$\bar{O}_n + 1$
L	L	┆	L	L	no change	
L	L	┆	H	L	H	L
L	L	┆	L	H	L	H
L	L	┆	H	H	\bar{O}_n	O_n

H= HIGH state (the more positive voltage)
 L= LOW state (the less positive voltage)
 X= state is immaterial
 ┆ = positive-going transition
 $O_n + 1$ = state after clock positive transition

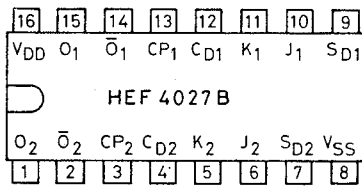

Pinning diagram

PINNING

- J, K synchronous inputs
- CP clock input (L to H edge-triggered)
- S_D asynchronous set-direct input (active HIGH)
- C_D asynchronous clear-direct input (active HIGH)
- O true output
- \bar{O} complement output

Hef4051B 8-CHANNEL ANALOGUE MULTIPLEXER/DEMULTIPLEXER

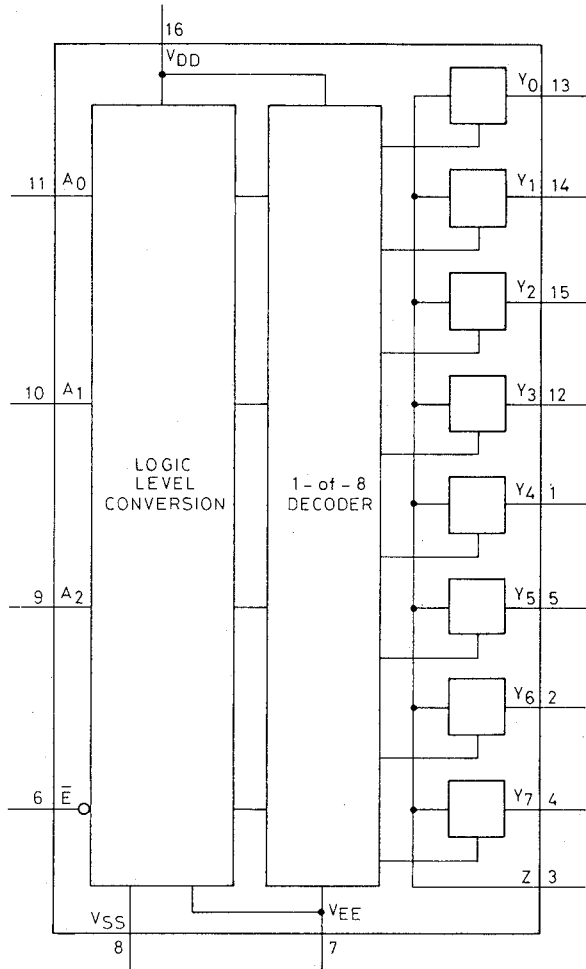

Functional diagram

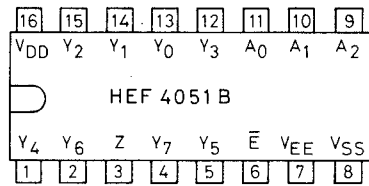

Pinning diagram

PINNING

- Y_0 to Y_7 independent inputs/outputs
- A_0 to A_2 address inputs
- \bar{E} enable input (active LOW)
- Z common input/output

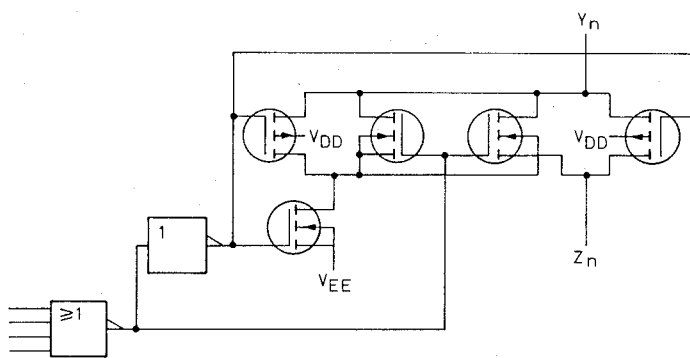

Schematic diagram (one switch)

FUNCTION TABLE

inputs				channel ON
\bar{E}	A_2	A_1	A_0	
L	L	L	L	Y_0-Z
L	L	L	H	Y_1-Z
L	L	H	L	Y_2-Z
L	L	H	H	Y_3-Z
L	H	L	L	Y_4-Z
L	H	L	H	Y_5-Z
L	H	H	L	Y_6-Z
L	H	H	H	Y_7-Z
H	X	X	X	none

- H = HIGH state (the more positive voltage)
- L = LOW state (the less positive voltage)
- X = state in immaterial

HEF4070B QUADRUPLE EXCLUSIVE-OR GATE

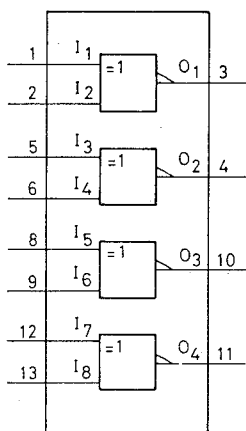

Functional diagram

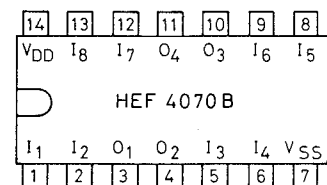

Pinning diagram

TRUTH TABLE

I ₁	I ₂	O ₁
L	L	L
H	L	H
L	H	H
H	H	L

H = HIGH state (the more positive voltage)
 L = LOW state (the less positive voltage)

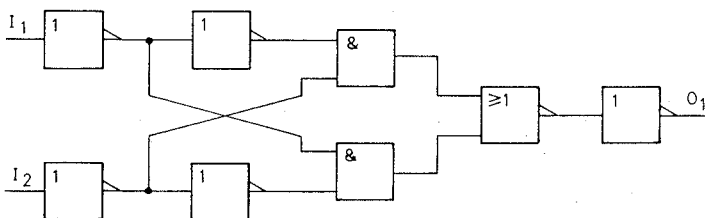

Logic diagram (one gate)

HEF40106B HEX SCHMITT TRIGGER

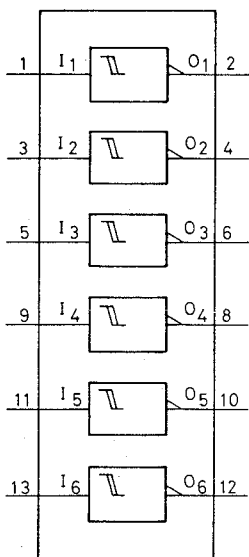

Functional diagram

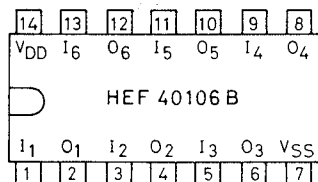

Pinning diagram

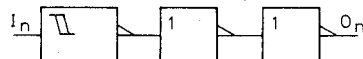

Logic diagram (one inverter)

HEF40174B HEX D-TYPE FLIP-FLOP

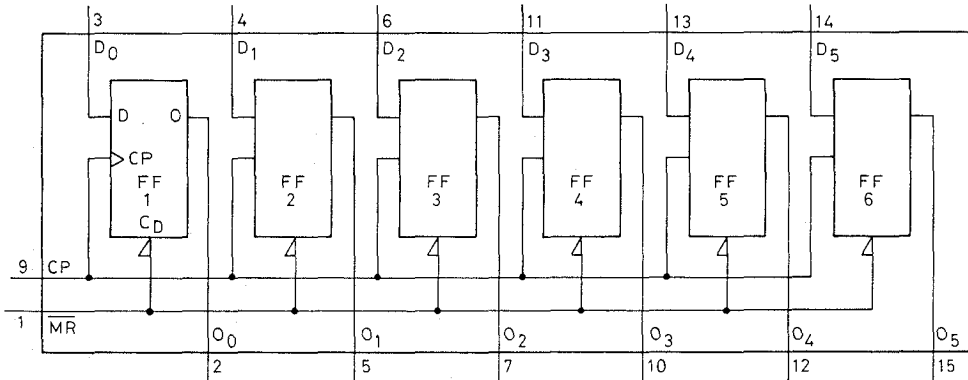

Functional diagram

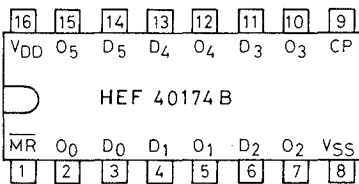

Pinning diagram

PINNING

- D₀ to D₅ data inputs
- CP clock input (LOW to HIGH edge triggered)
- MR master reset input (active LOW)
- O₀ to O₅ buffered outputs

FUNCTION TABLE

inputs			output
CP	D	MR	O
┌	H	H	H
┌	L	H	L
└	X	H	no change
X	X	L	L

- H = HIGH state (the more positive voltage)
- L = LOW state (the less positive voltage)
- X = state is immaterial
- ┌ = positive-going transition
- └ = negative going transition

8.3. OQ CIRCUITS

OQ0060 SWITCHING PART OF THE ADC

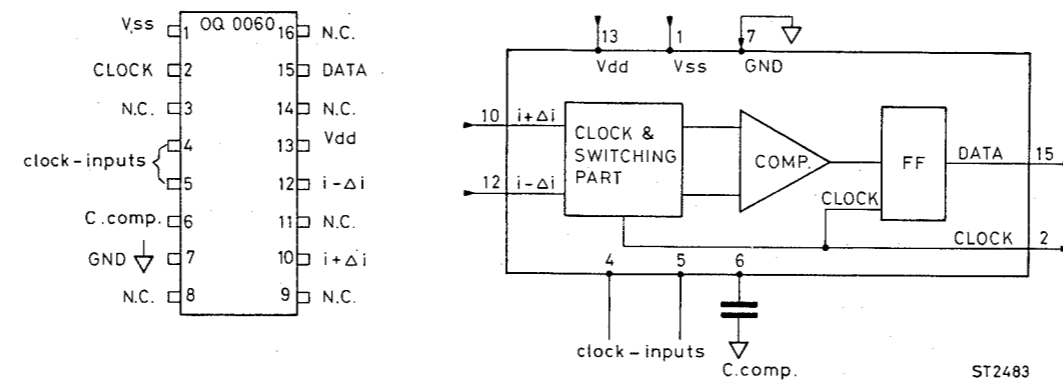

Specification of inputs and outputs

Pin nr.	Name	Description
1	Vss	Supply Negative supply voltage
2	CLOCK	Clock output
3	nc	no connection
4	clock	clock input
5	clock	clock input
6	C comp	Capacitor for compensation Capacitor compensates internal active parts
7	GND	Ground Supply zero ∇
8	n.c.	no connection
9	n.c.	no connection
10	$I + \Delta I$	Current input Input from V-I convertor
11	n.c.	no connection
12	$I - \Delta I$	Current input Input from V-I convertor
13	Vdd	Supply Positive supply voltage
14	n.c.	no connection
15	DATA	Data output Outgoing data with a duty-cycle depending on input voltage of the ADC
16	n.c.	no connection

OQ0061 AC TO DC CONVERTOR

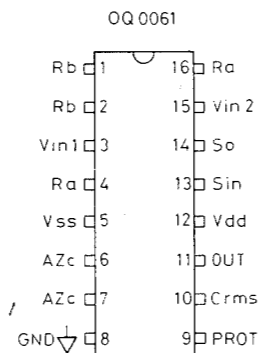
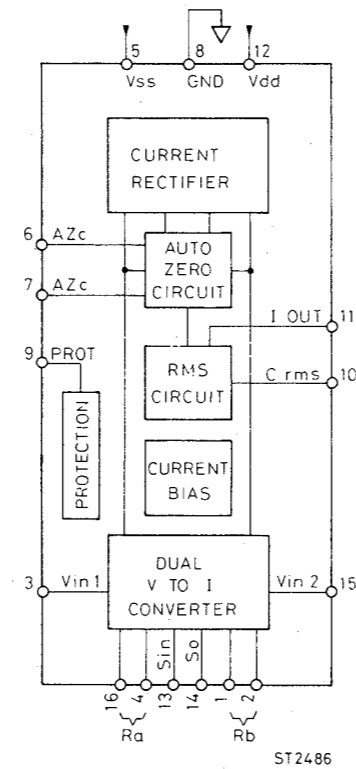

Specifications of inputs and outputs

Pin no.	Name	Description
1	Rb	Range b, conversion resistor
2	Rb	Range b, conversion resistor
3	Vin 1	Voltage input 1
4	Ra	Range a, conversion resistor
5	Vss	SUPPLY
6	AZc	Auto Zero
7	AZc	Decoupling capacitor
8	GND	GROUND
9	PROT	PROTECTION
10	Crms	R.M.S. averaging: capacitor
11	I out	Current output:
12	Vdd	SUPPLY
13	Sin	Range selecting; input
14	So	Range selecting: reference input
15	Vin 2	Voltage input 2;
16	Ra	Range a, conversion; resistor

Sin	So	Ra	Rb	Range	Sensitivity
0	1	X		200mV	0,1V
1	1		X	2V, 20V, 200V and 2000V	1V

NOTE: Above mentioned table is valid for PM2521.

The conversion resistor b is connected between inputs 1 and 2. The resistor determines the basic current of the V-I convertor. Rb is selected dependent on the code of Sin and So.

Input of the V to I convertor in the OQ0061.

The conversion resistor a is connected between inputs 4 and 16. The resistor determines the basic current of the V to I convertor. Ra is selected dependent on the code of Sin and So.

Negative supply voltage.

The auto zero decoupling capacitor C is alternately charged and discharged. When no DC offset is present, the voltage across the capacitor is zero. A DC offset causing a voltage across C, is compensated so no influence is seen upon the output signal.

Supply zero ↓

Protection input.

R.M.S. averaging: capacitor

Output current of the R.M.S. convertor. The current flowing through a known resistor gives the R.M.S. voltage of the unknown input voltage.

Positive supply.

By means of the Sin and So a selection can be made Ra or Rb, which determine the input sensitivity of the AD/DC conv.

OQ0063 PROGRAMMABLE CURRENT SOURCE

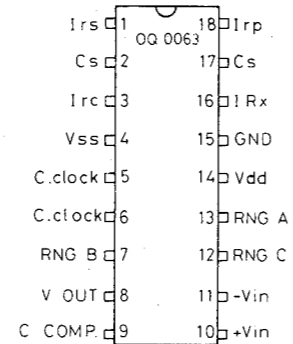
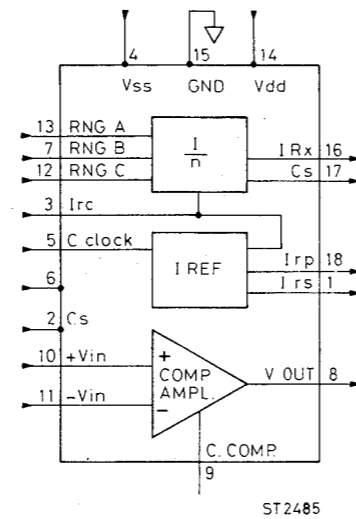

Specification of the inputs and outputs of the OQ0063

Pin no.	Name	Description
1	Irs	Ref. current adjustment With Rs the output current can be adjusted.
2	Cs	Smoothing Capacitor Smoothing capacitor for the switched currents.
3	Irc	I Ref. Common Common connection of Rs and Rp.
4	Vss	Supply Negative supply voltage.
5	C clock	Capacitor for the clock-oscillator.
6	C clock	
7	RNG B	Range B Range information (see 12, 13).
8	V out	Output voltage Output of the compensation amplifier.
9	C comp	C. Compensation Compensation capacitor for the compensation amplifier.
10	+Vin	+ and - input of the compensation/protection amplifier. Compensation: With the amplifier the current consumption of the ADC is compensated during Ω measurements. Protection: With the amplifier also the leak current through the protection diodes during Ω measurements is compensated.
11	-Vin	
12	RNG C	Range C Range A Together with signal RNG B the signals determine the digital range information from the μP .
13	RNG A	
14	Vdd	Supply Positive supply voltage.
15	GND	GROUND \downarrow Supply zero \downarrow
16	I out	Output current.
17	Cs	Smoothing capacitor.
18	Irp	With Rp the temperature-coefficient of the reference current is determined.

Range	Measuring current	RNG A	RNG B	RNG C
1 k Ω	1mA	1	1	1
10 k Ω	100 μA	0	0	0
100 k Ω	10 μA	1	0	0
1M Ω	1 μA	0	1	0
10M Ω	100 nA	1	1	0

OQ0064 V-I CONVERTOR (ADC)

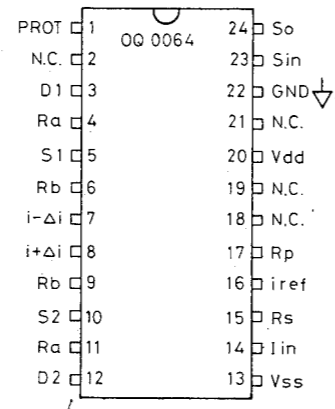
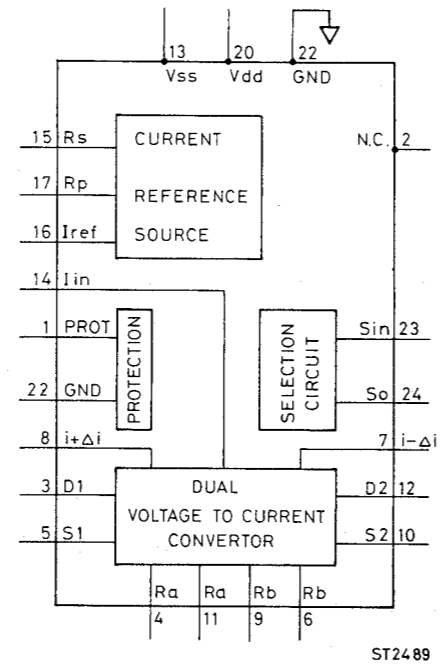

Specification of inputs and outputs

Pin no.	Name	Description
1	PROT	Protection input.
2	n.c.	no connection
3	D1	Drain input for device 1.
4	Ra	Range a conversion resistor (input sensitivity 0,1V).
5	S1	Source input for device 1.
6	Rb	Range b conversion resistor (input sensitivity 1V).
7	I	Current output.
8	I	Current output
9	Rb	Range b conversion resistor (input sensitivity 1V).
10	S2	Source input for device 2.
11	Ra	Range a conversion resistor (input sensitivity 0,1V).
12	D2	Drain input for device 2.
13	Vss	Negative supply voltage.
14	I in	Current input.
15	Rs	Current setting resistor. Adjustment reference current.
16	I ref	Current reference output.
17	Rp	Tc setting resistor. Rp determines temperature coefficient.
18	n.c.	no connection
19	n.c.	no connection
20	Vdd	Positive supply voltage.
21	n.c.	no connection.
22	GND	Supply Zero ↓
23	Sin	Range selecting input (a or b).
24	So	Range selecting reference input.

Sin	So	Ra	Rb	Sensitivity ADC
0	1	X		0,1V
1	1		X	1V

8.3. OQ CIRCUITS

OQ0060 SWITCHING PART OF THE ADC

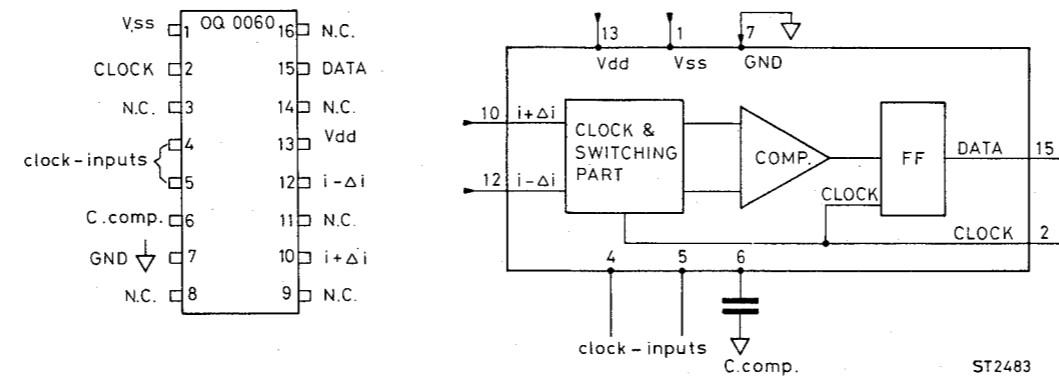

Specification of inputs and outputs

Pin nr.	Name	Description
1	Vss	Supply Negative supply voltage
2	CLOCK	Clock output
3	nc	no connection
4	clock	clock input
5	clock	clock input
6	C comp	Capacitor for compensation Capacitor compensates internal active parts
7	GND	Ground Supply zero ↓
8	n.c.	no connection
9	n.c.	no connection
10	I + ΔI	Current input Input from V-I convertor
11	n.c.	no connection
12	I - ΔI	Current input Input from V-I convertor
13	Vdd	Supply Positive supply voltage
14	n.c.	no connection
15	DATA	Data output Outgoing data with a duty-cycle depending on input voltage of the ADC
16	n.c.	no connection

OQ0061 AC TO DC CONVERTOR

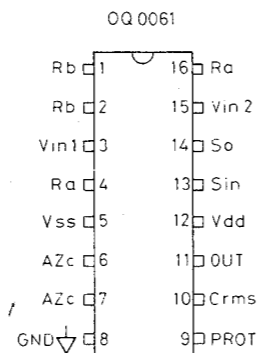
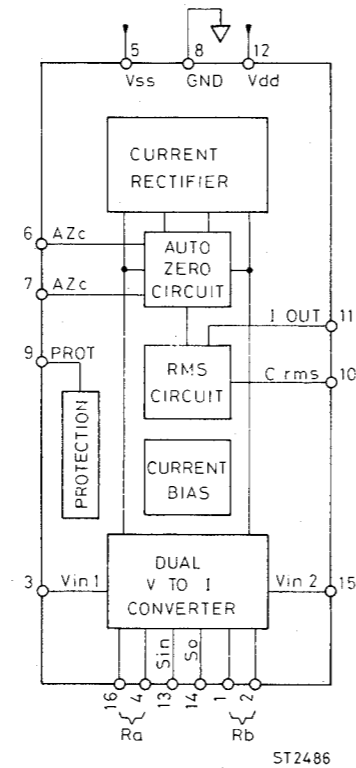

Specifications of inputs and outputs

Pin no.	Name	Description
1	Rb	Range b, conversion resistor
2	Rb	Range b, conversion resistor
3	Vin 1	Voltage input 1
4	Ra	Range a, conversion resistor
5	Vss	SUPPLY
6	AZc	Auto Zero
7	AZc	Decoupling capacitor
8	GND	GROUND
9	PROT	PROTECTION
10	Crms	R.M.S. averaging: capacitor
11	I out	Current output:
12	Vdd	SUPPLY
13	Sin	Range selecting; input
14	So	Range selecting: reference input
15	Vin 2	Voltage input 2;
16	Ra	Range a, conversion; resistor

Sin	So	Ra	Rb	Range	Sensitivity
0	1	X		200mV	0,1V
1	1		X	2V, 20V, 200V and 2000V	1V

NOTE: Above mentioned table is valid for PM2521.

The conversion resistor b is connected between inputs 1 and 2. The resistor determines the basic current of the V-I convertor. Rb is selected dependent on the code of Sin and So.

Input of the V to I convertor in the OQ0061.

The conversion resistor a is connected between inputs 4 and 16. The resistor determines the basic current of the V to I convertor. Ra is selected dependent on the code of Sin and So.

Negative supply voltage.

The auto zero decoupling capacitor C is alternately charged and discharged. When no DC offset is present, the voltage across the capacitor is zero. A DC offset causing a voltage across C, is compensated so no influence is seen upon the output signal.

Supply zero ↓

Protection input.

Output current of the R.M.S. convertor. The current flowing through a known resistor gives the R.M.S. voltage of the unknown input voltage.

Positive supply.

By means of the Sin and So a selection can be made Ra or Rb, which determine the input sensitivity of the AD/DC conv.

Input of the V to I convertor in the OQ0061.

The conversion resistor a is connected between inputs 4 and 16. The resistor determines the basic current of the V to I convertor. Ra is selected dependent on the code of Sin and So.

OO0063 PROGRAMMABLE CURRENT SOURCE

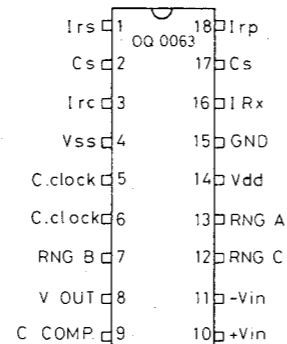
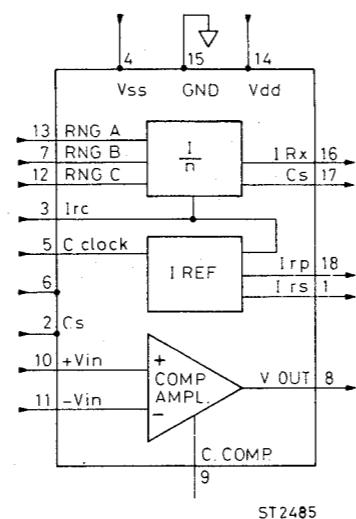

Specification of the inputs and outputs of the OO0063

Pin no.	Name	Description
1	Irs	Ref. current adjustment With Rs the output current can be adjusted.
2	Cs	Smoothing Capacitor Smoothing capacitor for the switched currents.
3	Irc	I Ref. Common Common connection of Rs and Rp.
4	Vss	Supply Negative supply voltage.
5	C clock	Capacitor for the clock-oscillator.
6	C clock	
7	RNG B	Range B Range information (see 12, 13).
8	V out	Output voltage Output of the compensation amplifier.
9	C comp	C. Compensation Compensation capacitor for the compensation amplifier.
10	+Vin	+ and - input of the compensation/protection amplifier. Compensation: With the amplifier the current consumption of the ADC is compensated during Ω measurements. Protection: With the amplifier also the leak current through the protection diodes during Ω measurements is compensated.
11	-Vin	
12	RNG C	Range C Range A Together with signal RNG B the signals determine the digital range information from the μP .
13	RNG A	
14	Vdd	Supply Positive supply voltage.
15	GND	GROUND \downarrow Supply zero \downarrow
16	I out	Output current.
17	Cs	Smoothing capacitor.
18	Irp	With Rp the temperature-coefficient of the reference current is determined.

Range	Measuring current	RNG A	RNG B	RNG C
1 k Ω	1mA	1	1	1
10 k Ω	100 μ A	0	0	0
100 k Ω	10 μ A	1	0	0
1M Ω	1 μ A	0	1	0
10M Ω	100 nA	1	1	0

OQ0064 V-I CONVERTOR (ADC)

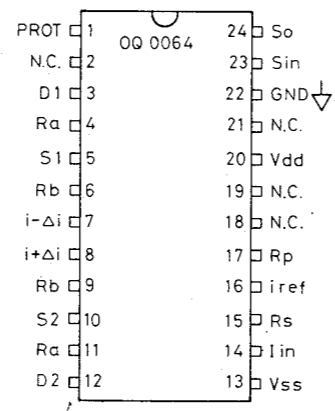
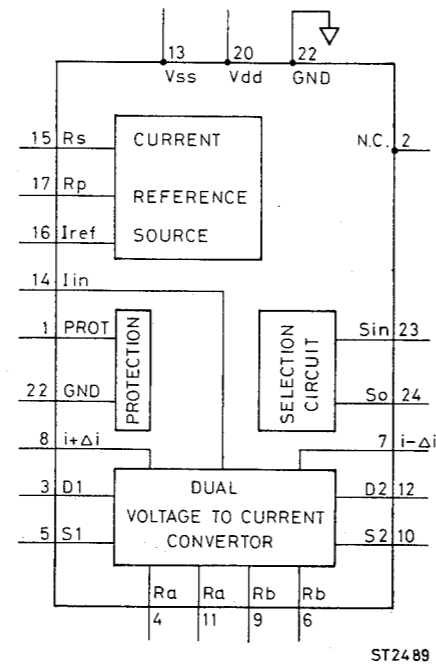

Specification of inputs and outputs

Pin no.	Name	Description
1	PROT	Protection input.
2	n.c.	no connection
3	D1	Drain input for device 1.
4	Ra	Range a conversion resistor (input sensitivity 0,1V).
5	S1	Source input for device 1.
6	Rb	Range b conversion resistor (input sensitivity 1V).
7	I	Current output.
8	I	Current output
9	Rb	Range b conversion resistor (input sensitivity 1V).
10	S2	Source input for device 2.
11	Ra	Range a conversion resistor (input sensitivity 0,1V).
12	D2	Drain input for device 2.
13	Vss	Negative supply voltage.
14	I in	Current input.
15	Rs	Current setting resistor. Adjustment reference current.
16	I ref	Current reference output.
17	Rp	Tc setting resistor. Rp determines temperature coefficient.
18	n.c.	no connection
19	n.c.	no connection
20	Vdd	Positive supply voltage.
21	n.c.	no connection.
22	GND	Supply Zero ↓
23	Sin	Range selecting input (a or b).
24	So	Range selecting reference input.

Sin	So	Ra	Rb	Sensitivity ADC
0	1	X		0,1V
1	1		X	1V

8.4. DISPLAY INTERFACE CIRCUITS

SAA1060 LED DISPLAY/INTERFACE CIRCUIT

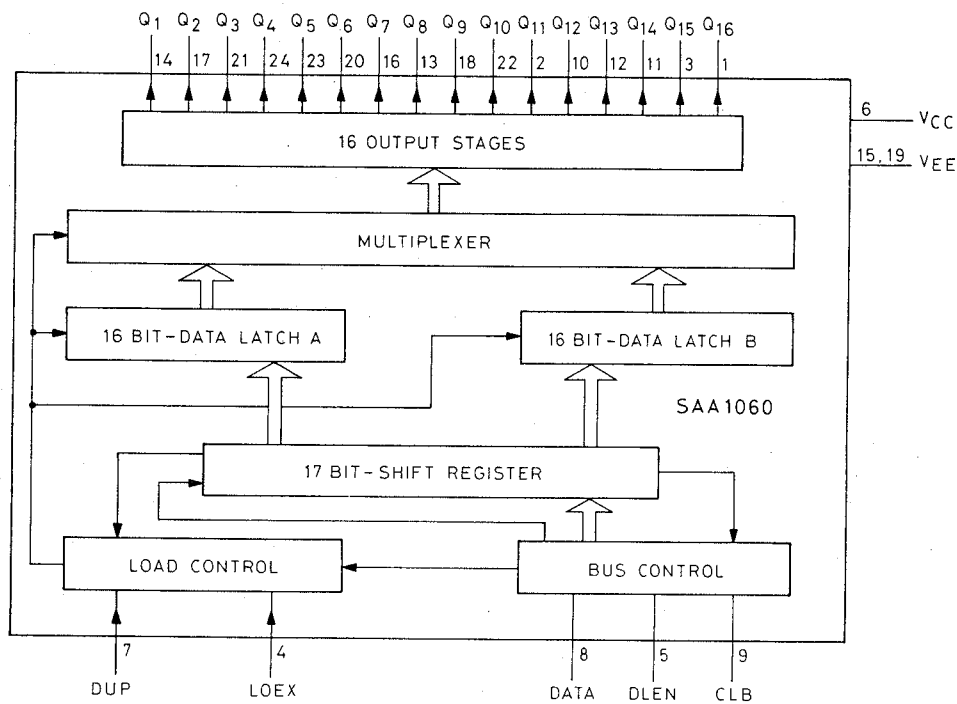

Block diagram

GENERAL DESCRIPTION

Data transmission is initiated by means of a burst of clock pulses (CLB), a data line enable signal (DLEN) and the data signal (DATA). The bus control circuit distinguishes between interference and valid data by checking word length (17 bits) and the leading zero. This allows different bus information to be supplied on the same bus lines for other circuits (e.g. SAA1056 with 16 bits).

The last bit (bit 17) of the data word contains the information which of the two internal latches will be loaded. The input LOEX determines if the latched data of the selected latches is presented directly to the outputs, or synchronized with the data select signal DUP.

The output stages are n-p-n transistors with open collectors. The current capability is designed for the requirements of duplex operation. Two of the outputs (Q_8 and Q_{16}) are arranged for double current, so that 2×2 segments can be connected in parallel.

OPERATION DESCRIPTION

Data inputs (DLEN, DATA)

The SAA1060 processes serially the 18-bit data words synchronized with the clock burst (CLB) and applied to the data input DATA. A command will be accepted only when the data line enable input (DLEN) is HIGH.

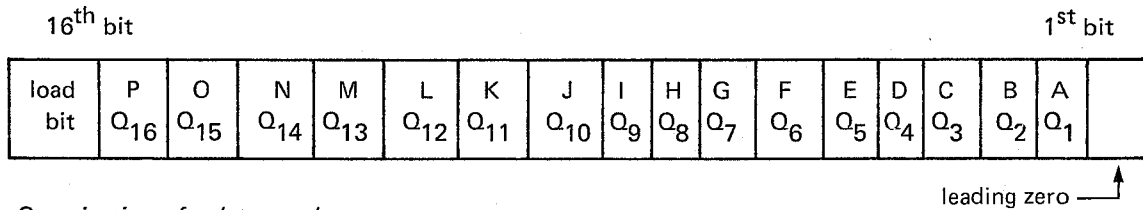

Organization of a data word

Condition for 17th bit:

- 0 = load data latch B
- 1 = load data latch A

The loading of the accepted information in one of the data latches is done by the 19th clock pulse, when DLEN is LOW.

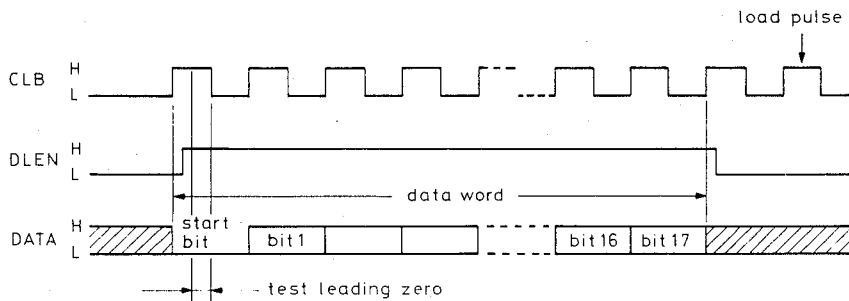

Pulse diagram of the 16-bit data transmission

Each data word must start with a leading zero. The SAA1060 checks the data word for the correct length (18 bits) and also for the leading zero.

The actual data is switched directly to the appropriate outputs. For switching on a segment, a "0" (LOW) is necessary at the appropriate data bit.

Data selection input (DUP)

The logic states at input DUP determine which of the two latch contents can be found on the output.

- 0 = latch A contents
- 1 = latch B contents

Load control input (LOEX)

Input LOEX determines the operation mode in which the device is able to work.

- 0 = duplex mode, i.e. output synchronized with the duplex signal
- 1 = d.c. mode, i.e. output direct from the DUP selected data latch.

When operating in duplex mode at 50Hz, the time between two data words to be transmitted must be > 21ms.

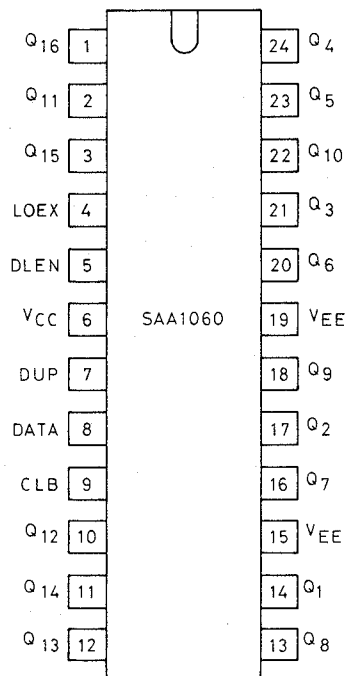

Pinning diagram

RATINGS ($V_{EE} = 0$)

Limiting values in accordance with the Absolute Maximum System (IEC134)

Supply voltage range	V_{CC}	-0.3 to +7V
Total power dissipation	P_{tot}	max. 900mW
Operating ambient temperature range	T_{amb}	-20 to +80°C
Storage temperature range	T_{stg}	-25 to +125°C

SAA1062 LCD DISPLAY/INTERFACE CIRCUIT

GENERAL DESCRIPTION

The SAA1062 is designed to drive a Liquid Crystal Display (LCD) of a digital tuning system. It contains a shift register with programmable length (18 or 21 bits), latches, both synchronized or static, exclusive-OR segment drivers (17 or 20 bits), an l.f. oscillator and a backplane driver for the LCD. The circuit is designed to be driven by a 3 bus structure from a microprocessor and can also be used as a programmable 17 or 20 bits serial-to-parallel decoder. It is also capable of storing 60 bits of information.

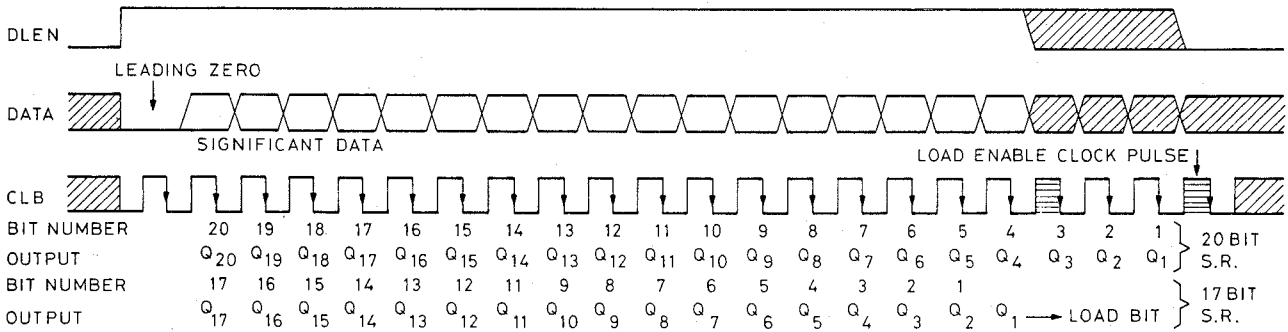

Organization of 18 and 21 bits words; DATA - LOW means segment 'on'

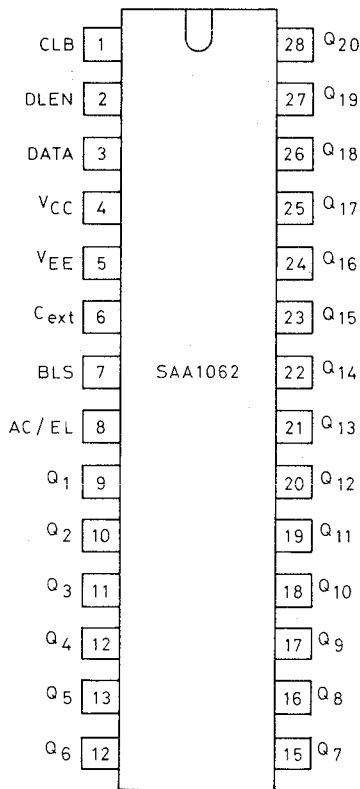

Pinning diagram

8.5. OPERATIONAL AMPLIFIERS

DIFFERENTIAL VOLTAGE COMPARATOR $\mu A710$

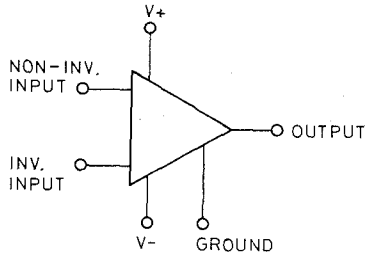

PIN CONFIGURATION (TOP VIEW)

A PACKAGE

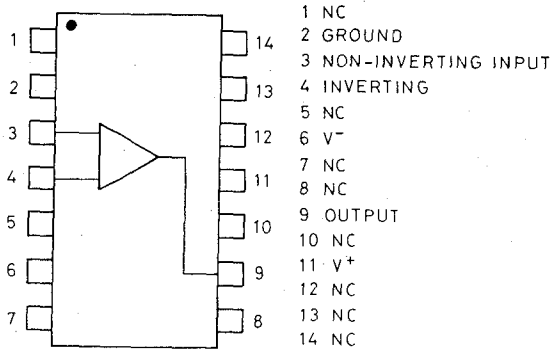

T PACKAGE

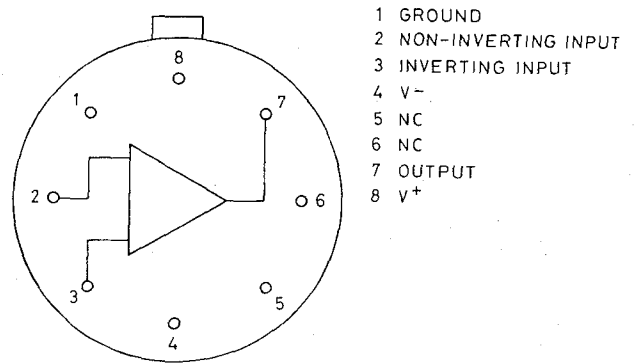

PRECISION OPERATIONAL AMPLIFIER $\mu A714$

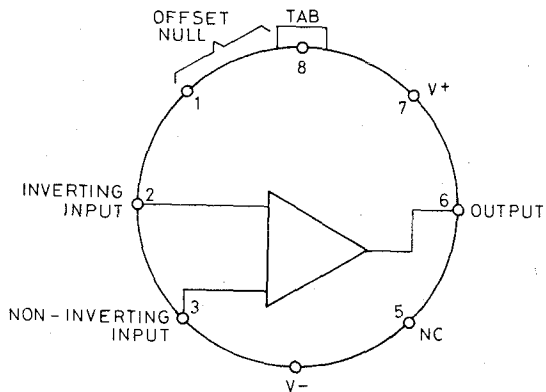

GENERAL PURPOSE OPERATIONAL AMPLIFIER μ A741

PIN CONFIGURATIONS (TOP VIEW)

A PACKAGE

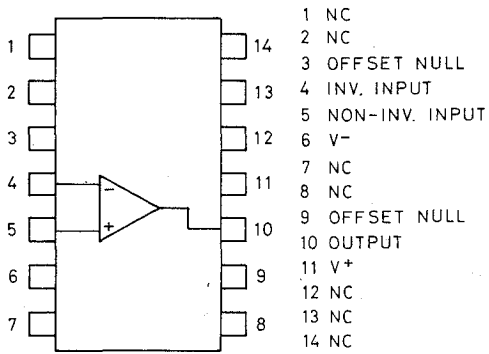

T PACKAGE

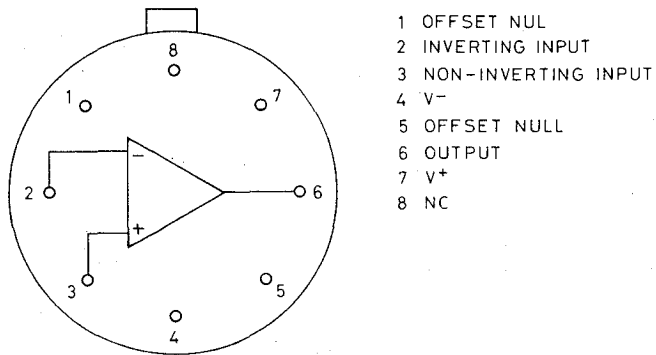

V PACKAGE

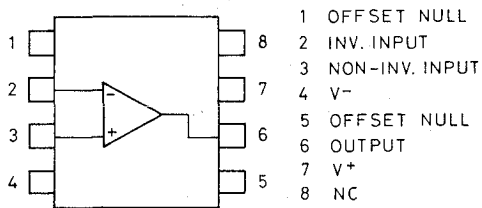

8.6. LOW POWER SCHOTTKY CIRCUITS (LS)

LOW POWER SCHOTTKY 54LS/74LS FAMILY CHARACTERISTICS
DC CHARACTERISTICS OVER OPERATING TEMPERATURES

Parameter	Test conditions	Limits			Unit
		Min	Typ ¹	Max	
V_{IH} Input HIGH voltage	Guaranteed input HIGH voltage for all inputs	2.0			V
V_{IL} Input LOW voltage	Guaranteed input LOW voltage for inputs	Mil		0.7	V
		Com		0.8	V
V_{CD} Input clamp diode voltage	$V_{CC} = \text{Min. } I_{IN} = -18\text{mA}$		-0.65	-1.5	V
V_{OL} Output LOW voltage	$V_{CC} = \text{Min. } I_{OL} = 4.0\text{mA}$		0.25	0.4	V
	$V_{CC} = \text{Min. } I_{OL} = 8.0\text{mA (Com. only)}$		0.35	0.5	V
V_{OH} Output HIGH voltage	$V_{CC} = \text{Min. } I_{OH} = -400\mu\text{A}$	Mil	2.5	3.4	V
		Com	2.7	3.4	V
I_{OH} Output HIGH current (open collector)	$V_{CC} = \text{Min. } V_{OUT} = 5.5\text{V}$			100	μA
I_{OZH} Output "off" current HIGH (3-state)	$V_{CC} = \text{Max. } V_{OUT} = 2.4\text{V}$ $V_{OE} = 2.0\text{V}$			20	μA
I_{OZL} Output "off" current LOW (3-state)	$V_{CC} = \text{Max. } V_{OUT} = 0.4\text{V}$ $V_{OE} = 2.0\text{V}$			-20	μA
I_{IH} Input HIGH current ²	$V_{CC} = \text{Max. } V_{IN} = 2.7\text{V}$			20	μA
I_I Input HIGH current at Max input voltage	$V_{CC} = \text{Max. } V_{IN} = 10\text{V}^3$			0.1	mA
I_{IL} Input LOW current ²	$V_{CC} = \text{Max. } V_{IN} = 0.4\text{V}$			-0.4	mA
I_{OS} Output short circuit current	$V_{CC} = \text{Max. } V_{OUT} = 0\text{V}$	-15		-100	mA

NOTES:

1. Typical limits are at 25°C and $V_{CC}=5.0\text{V}$
2. The specified limits reflect one unit load for the family. When more than one load is connected internally, the limits must be multiplied by the number of connected loads. See the INPUT AND OUTPUT LOADING AND FAN-OUT TABLE on the data sheets for the guaranteed limit for each input.
3. The following LS devices are limited to a 5.5V input breakdown voltage. All inputs of the LS181; clock inputs of LS90, LS92, LS93, LS196, LS197, LS290, LS293, LS390, LS393 and LS490.

**QUAD 2-INPUT NAND GATE
PIN CONFIGURATIONS**

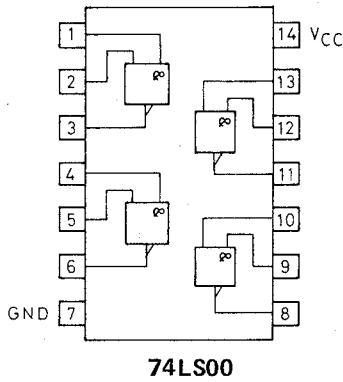

**TRIPLE 3-INPUT NAND GATE
PIN CONFIGURATIONS**

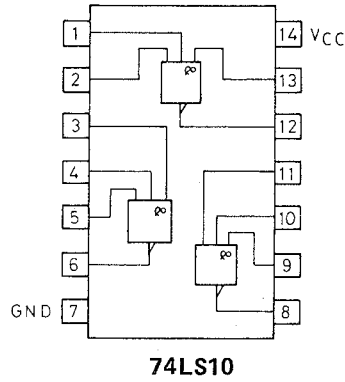

**QUAD 2-INPUT EXCLUSIVE-OR GATE
PIN CONFIGURATIONS**

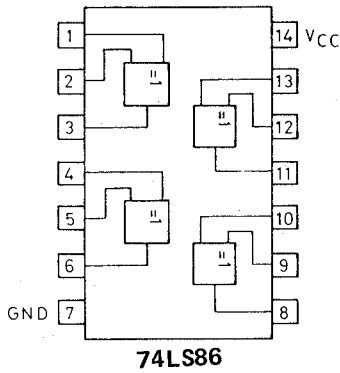

TRUTH TABLE

inputs		output
A	B	Y
L	L	L
L	H	H
H	L	H
H	H	L

L = LOW voltage level.
H = HIGH voltage level.

**74LS244 OCTAL BUFFERS (3-STATE)
PIN CONFIGURATIONS**

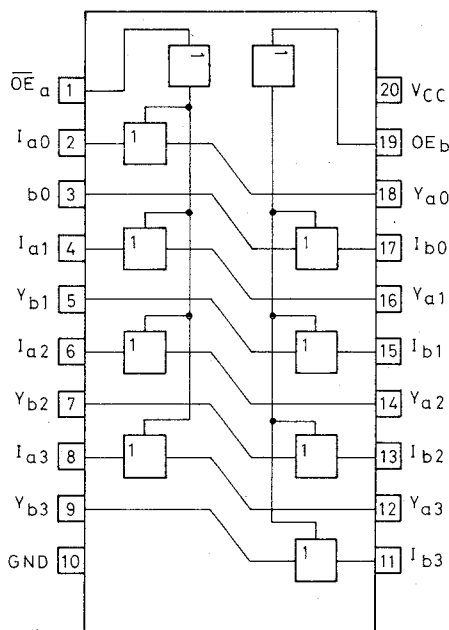

TRUTH TABLE

Inputs				Outputs	
\overline{OE}_a	I_a	\overline{OE}_b	I_b	Y_a	Y_b
L	L	L	L	L	L
L	H	L	H	H	H
H	X	H	X	(Z)	(Z)

H = HIGH voltage level
L = LOW voltage level
X = Don't care
(Z) = High impedance (off) state

74LS74 DUAL D-TYPE FLIP FLOP

PIN CONFIGURATION

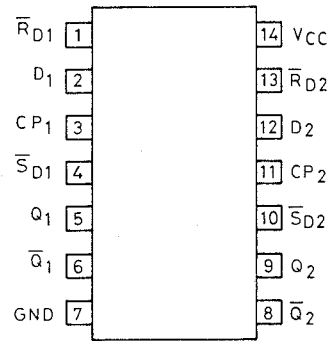

LOGIC SYMBOL

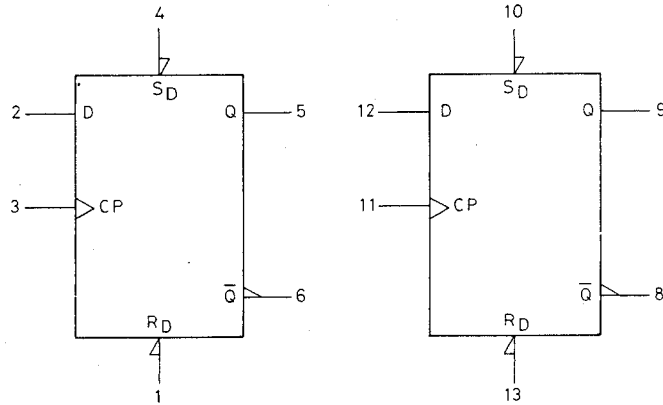

LOGIC DIAGRAM

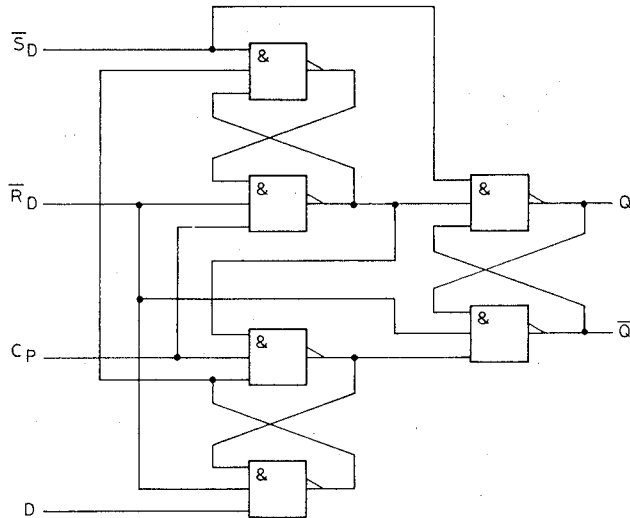

MODE SELECT-TRUTH TABLE

OPERATING MODE	inputs				outputs	
	\bar{S}_D	\bar{R}_D	CP	D	Q	\bar{Q}
Asynchronous Set	L	H	X	X	H	L
Asynchronous Reset (Clear)	H	L	X	X	L	H
Undetermined (c)	L	L	X	X	H	H
Load "1" (Set)	H	H	↑	h	H	L
Load "0" (Reset)	H	H	↑	l	L	H

- H = HIGH voltage level steady state.
- h = HIGH voltage level one setup time prior to the LOW to HIGH clock transition.
- L = LOW voltage level steady state.
- l = LOW voltage level one setup time prior to the LOW to HIGH clock transition.
- X = Don't care.

**74LS161 4-BIT BINARY COUNTER
PIN CONFIGURATION**

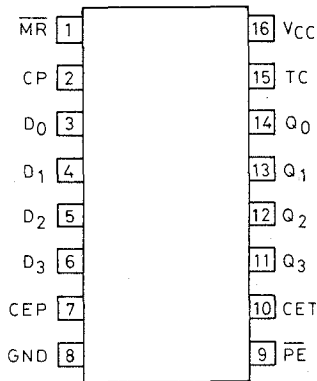

LOGIC SYMBOL

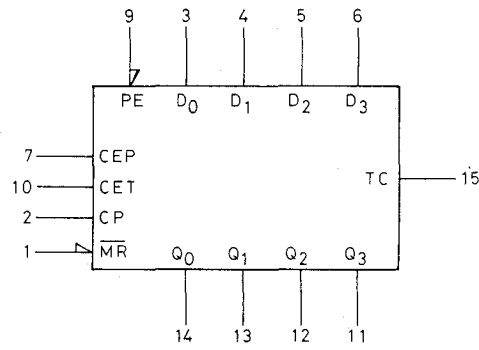

MODE SELECT-FUNCTION TABLE

OPERATING MODE	Inputs						Outputs	
	$\overline{\text{MR}}$	CP	CEP	CET	$\overline{\text{PE}}$	D_n	Q_n	TC
Reset (Clear)	L	X	X	X	X	X	L	L
Parallel Load	H	↑	X	X	l	l	L	L
	H	↑	X	X	l	h	H	(b)
Count	H	↑	h	h	h(d)	X	count	(b)
Hold (do nothing)	H	X	l(c)	X	h(d)	X	Q_n	(b)
	H	X	X	l(c)	h(d)	X	Q_n	L

H = HIGH voltage level steady state

L = LOW voltage level steady state

h = HIGH voltage level one setup time prior to the LOW-to-HIGH clock transition

l = LOW voltage level one setup time prior to the LOW-to-HIGH clock transition

X = Don't care

Q = Lower case letters indicate the state of the referenced output prior to the LOW-to-HIGH clock transition

↑ = LOW-to-HIGH clock transition

8.7. MEMORY AND MICROPROCESSOR

2716

16k (2kx8) UV ERASABLE PROM

PIN CONFIGURATION

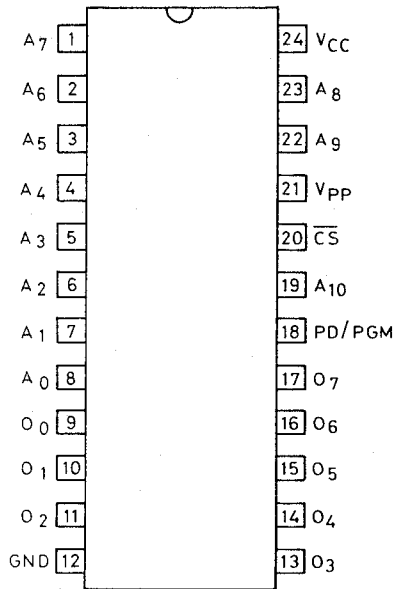

PIN NAMES

A ₀ -A ₁₀	ADDRESSES
PD/PGM	POWER DOWN/PROGRAM
CS	CHIP SELECT
O ₀ -O ₇	OUTPUTS

BLOCK DIAGRAM

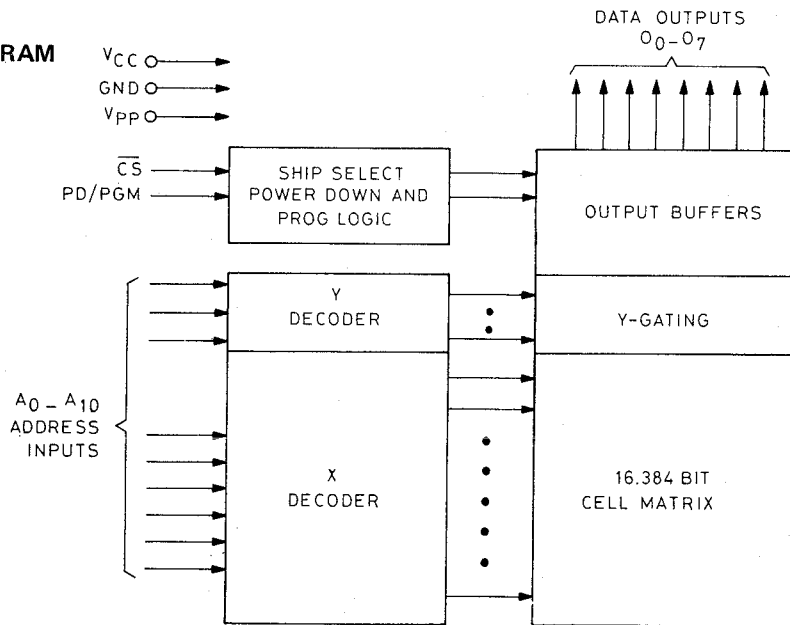

MODE SELECTION

Pins / Mode	CE/PGM (18)	OE (20)	Vpp (21)	V _{CC} (24)	Outputs (9-11, 13-17)
Read	V _{IL}	V _{IL}	+5	+5	D _{OUT}
Standby	V _{IL}	Don't care	+5	+5	High Z
Program	Pulsed V _{IL} to V _{IH}	V _{IH}	+25	+5	D _{IN}
Program Verify	V _{IL}	V _{IL}	+25	+5	D _{OUT}
Program Inhibit	V _{IL}	V _{IH}	+25	+5	High Z

8035

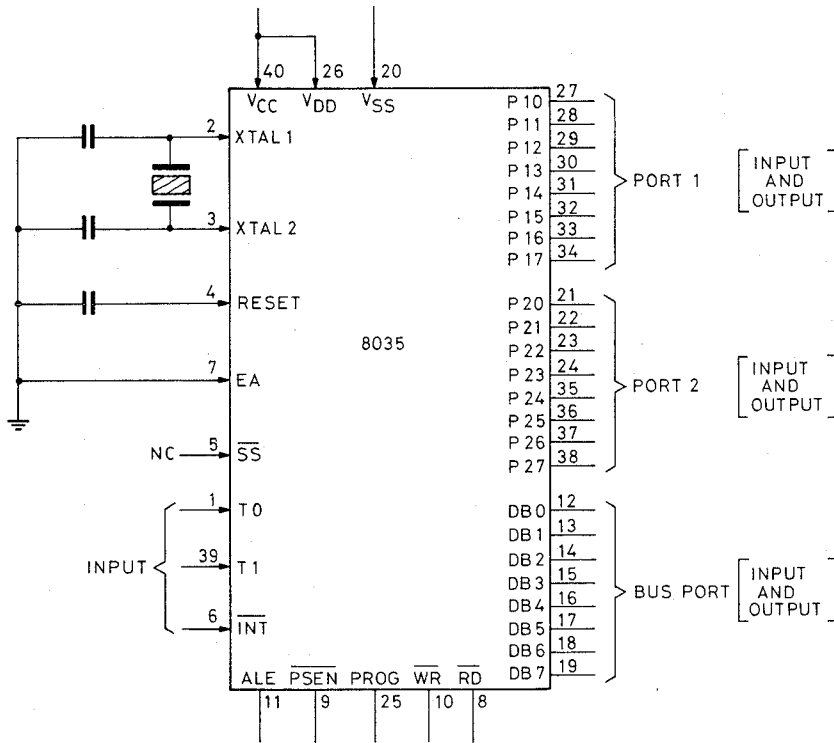

MCS-48 PIN CONFIGURATIONS

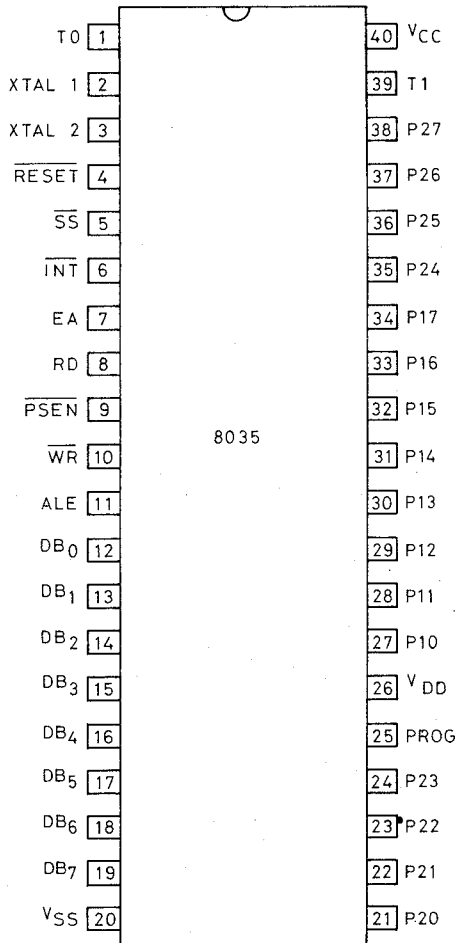

Designation	Pin number	Function
V _{SS}	20	Circuit GND potential
V _{DD}	26	Programming power supply; +25V during program, +5V during operation for both ROM and PROM. Low power standby pin in 8048 ROM version.
V _{CC}	40	Main power supply; +5V during operation and 8748 programming.
PROG	25	Program pulse (+25V) input pin during 8748 programming. Output strobe for 8232 I/O expander.
P10-P17 (Port 1)	27-34	8-bit quasi-bidirectional port. Internal Pullup $\approx 50K\Omega$)
P20-P27 (Port 2)	21-24 35-38	8-bit quasi-bidirectional port. (Internal Pullup $\approx 50K\Omega$) P20-P23 contain the four high order program counter bits during an external program memory fetch and serve as a 4-bit I/O expander bus for 8243.
D0-D7	12-19	True bidirectional port which can be written or read synchronously using the RD, WR strobes. The port can also be statically latched. Contains the 8 low order program counter bits during an external program memory fetch, and receives the addressed instruction under the control of PSEN. Also contains the address and data during an external RAM data store instruction, under control of ALE, RD, and WR.
T0	1	Input pin testable using the conditional transfer instructions JTO and JNT0. T0 can be designated as a clock output using ENTO CLK instruction. T0 is also used during programming.
T1	39	Input pin testable using the JT1, and JNT1 instructions. Can be designated the event counter input using the STRT CNT instruction.
INT	6	Interrupt input. Initiates an interrupt if interrupt is enabled. Interrupt is disabled after a reset. (Active low)
RD	8	Output strobe activated during a BUS read. Can be used to enable data onto the BUS from an external device. (Active low). Used as a Read Strobe to External Data Memory.
RESET	4	Input which is used to initialize the processor. Also used during PROM programming and verification. (Active low). (Internal pullup $\approx 200K\Omega$).
WR	10	Output strobe during a BUS write. (Active low). Used as write strobe to external data memory.
ALE	11	Address Latch Enable. This signal occurs once during each cycle and is useful as a clock output. The negative edge of ALE strobes address into external data and program memory.
PSEN	9	Program Store Enable. This output occurs only during a fetch to external program memory. (Active Low).
SS	5	Single step input can be used in conjunction with ALE to "single step" the processor through each instruction. (Active Low) (Internally pullup $\approx 300K\Omega$).
EA	7	External Access input which forces all program memory fetches to reference external memory. Useful for emulation and debug, and essential for testing and program verification. (Active High) Internal pullup $\approx 10M\Omega$) on 8048/8049, 8035L, 8039 only).
XTAL1	2	One side of crystal input for internal oscillator. Also input for external source.
XTAL2	3	Other side of crystal input.

8.8. RESISTORS

INTEGRATED RESISTOR OM530

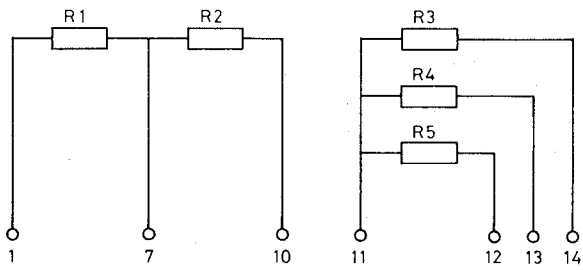
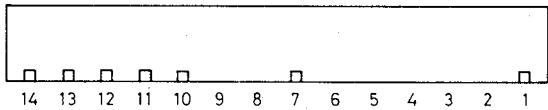
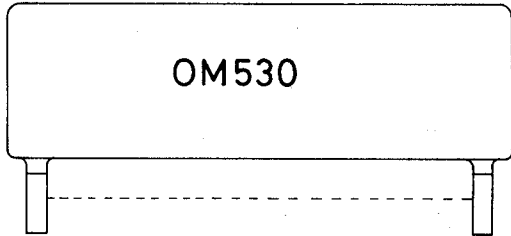

- R1 10 M
- R2 9M96
- R3 555k 555
- R4 50k 505
- R5 5k005

ST3445
820208

**CODING SYSTEM OF FAILURE REPORTING FOR QUALITY
ASSESSMENT OF T & M INSTRUMENTS
(excl. potentiometric recorders)**

The information contents of the coded failure description is necessary for our computerized processing of quality data.

Since the reporting of repair and maintenance routines must be complete and exact, we give you an example of a correctly filled-out PHILIPS SERVICE Job sheet.

①	②	③	/Version	④
Country	Day Month Year	Typenumber		Factory/Serial no.
3 2	1 5 0 4 7 5	O P M 3 2 6 0 0 2		D O 0 0 7 8 3

CODED FAILURE DESCRIPTION ⑥

⑤	Location	Component/sequence no.	Category		⑦																																																																
<table border="1" style="width: 100%; border-collapse: collapse;"> <tr><td style="width: 20px; height: 20px;"><input type="checkbox"/></td><td>Installation</td></tr> <tr><td style="width: 20px; height: 20px;"><input type="checkbox"/></td><td>Pre sale repair</td></tr> <tr><td style="width: 20px; height: 20px;"><input type="checkbox"/></td><td>Preventive maintenance</td></tr> <tr><td style="width: 20px; height: 20px;"><input checked="" type="checkbox"/></td><td>Corrective maintenance</td></tr> <tr><td style="width: 20px; height: 20px;"><input type="checkbox"/></td><td>Other</td></tr> </table>	<input type="checkbox"/>	Installation	<input type="checkbox"/>	Pre sale repair	<input type="checkbox"/>	Preventive maintenance	<input checked="" type="checkbox"/>	Corrective maintenance	<input type="checkbox"/>	Other	<table border="1" style="width: 100%; border-collapse: collapse;"> <tr><td style="width: 20px; height: 20px;"></td><td style="width: 20px; height: 20px;"></td><td style="width: 20px; height: 20px;"></td><td style="width: 20px; height: 20px;"></td></tr> <tr><td style="width: 20px; height: 20px;"></td><td style="width: 20px; height: 20px;"></td><td style="width: 20px; height: 20px;"></td><td style="width: 20px; height: 20px;"></td></tr> <tr><td style="width: 20px; height: 20px;">0 0</td><td style="width: 20px; height: 20px;">2 1</td><td style="width: 20px; height: 20px;"></td><td style="width: 20px; height: 20px;"></td></tr> <tr><td style="width: 20px; height: 20px;"></td><td style="width: 20px; height: 20px;"></td><td style="width: 20px; height: 20px;"></td><td style="width: 20px; height: 20px;"></td></tr> <tr><td style="width: 20px; height: 20px;"></td><td style="width: 20px; height: 20px;"></td><td style="width: 20px; height: 20px;"></td><td style="width: 20px; height: 20px;"></td></tr> </table>									0 0	2 1											<table border="1" style="width: 100%; border-collapse: collapse;"> <tr><td style="width: 20px; height: 20px;">T</td><td style="width: 20px; height: 20px;">S</td><td style="width: 20px; height: 20px;">0</td><td style="width: 20px; height: 20px;">6</td><td style="width: 20px; height: 20px;">0</td><td style="width: 20px; height: 20px;">7</td></tr> <tr><td style="width: 20px; height: 20px;">R</td><td style="width: 20px; height: 20px;">0</td><td style="width: 20px; height: 20px;">6</td><td style="width: 20px; height: 20px;">3</td><td style="width: 20px; height: 20px;">1</td><td style="width: 20px; height: 20px;"></td></tr> <tr><td style="width: 20px; height: 20px;">9</td><td style="width: 20px; height: 20px;">9</td><td style="width: 20px; height: 20px;">0</td><td style="width: 20px; height: 20px;">0</td><td style="width: 20px; height: 20px;">0</td><td style="width: 20px; height: 20px;">1</td></tr> <tr><td style="width: 20px; height: 20px;"></td><td style="width: 20px; height: 20px;"></td><td style="width: 20px; height: 20px;"></td><td style="width: 20px; height: 20px;"></td><td style="width: 20px; height: 20px;"></td><td style="width: 20px; height: 20px;"></td></tr> <tr><td style="width: 20px; height: 20px;"></td><td style="width: 20px; height: 20px;"></td><td style="width: 20px; height: 20px;"></td><td style="width: 20px; height: 20px;"></td><td style="width: 20px; height: 20px;"></td><td style="width: 20px; height: 20px;"></td></tr> </table>	T	S	0	6	0	7	R	0	6	3	1		9	9	0	0	0	1													<table border="1" style="width: 100%; border-collapse: collapse;"> <tr><td style="width: 20px; height: 20px;">5</td></tr> <tr><td style="width: 20px; height: 20px;">2</td></tr> <tr><td style="width: 20px; height: 20px;">4</td></tr> <tr><td style="width: 20px; height: 20px;"></td></tr> <tr><td style="width: 20px; height: 20px;"></td></tr> </table>	5	2	4			Job completed <input checked="" type="checkbox"/>
<input type="checkbox"/>	Installation																																																																				
<input type="checkbox"/>	Pre sale repair																																																																				
<input type="checkbox"/>	Preventive maintenance																																																																				
<input checked="" type="checkbox"/>	Corrective maintenance																																																																				
<input type="checkbox"/>	Other																																																																				
0 0	2 1																																																																				
T	S	0	6	0	7																																																																
R	0	6	3	1																																																																	
9	9	0	0	0	1																																																																
5																																																																					
2																																																																					
4																																																																					
					Working time ⑧ <table border="1" style="width: 100%; border-collapse: collapse;"> <tr><td style="width: 20px; height: 20px;"></td><td style="width: 20px; height: 20px;">1</td><td style="width: 20px; height: 20px;">2</td></tr> </table> Hrs		1	2																																																													
	1	2																																																																			

Detailed description of the information to be entered in the various boxes:

①Country: 3 2 = Switzerland

②Day Month Year 1 5 0 4 7 5 = 15 April 1975

③Type number/Version O P M 3 2 6 0 0 2 = Oscilloscope PM 3260, version 02 (in later oscilloscopes this number is placed in front of the serial no)

④Factory/Serial number D O 0 0 7 8 3 = DO 783 These data are mentioned on the type plate of the instrument

⑤ Nature of call: Enter a cross in the relevant box

⑥ Coded failure description

<p>Location</p> <table border="1" style="width: 100%; border-collapse: collapse;"> <tr><td style="width: 20px; height: 20px;"></td><td style="width: 20px; height: 20px;"></td><td style="width: 20px; height: 20px;"></td><td style="width: 20px; height: 20px;"></td></tr> </table> <p>These four boxes are used to isolate the problem area. Write the code of the part in which the fault occurs, e.g. unit no or mechanical item no of this part (refer to 'PARTS LISTS' in the manual). Example: 0001 for Unit 1 000A for Unit A 0075 for item 75</p> <p>If units are not numbered, do not fill in the four boxes; see Example Job sheet.</p>					<p>Component/sequence no.</p> <table border="1" style="width: 100%; border-collapse: collapse;"> <tr><td style="width: 20px; height: 20px;"></td><td style="width: 20px; height: 20px;"></td><td style="width: 20px; height: 20px;"></td><td style="width: 20px; height: 20px;"></td><td style="width: 20px; height: 20px;"></td><td style="width: 20px; height: 20px;"></td></tr> </table> <p>These six boxes are intended to pinpoint the faulty component. A. Enter the component designation as used in the circuit diagram. If the designation is alfa-numeric, the letters must be written (starting from the left) in the two left-hand boxes and the figures must be written (in such a way that the last digit occupies the right-most box) in the four right-hand boxes. B. Parts not identified in the circuit diagram: 990000 Unknown/Not applicable 990001 Cabinet or rack (text plate, emblem, grip, rail, graticule, etc.) 990002 Knob (incl. dial knob, cap, etc.) 990003 Probe (only if attached to instrument) 990004 Leads and associated plugs 990005 Holder (valve, transistor, fuse, board, etc.) 990006 Complete unit (p.w. board, h.t. unit, etc.) 990007 Accessory (only those without type number) 990008 Documentation (manual, supplement, etc.) 990009 Foreign object 990099 Miscellaneous</p>							<p>Category</p> <table border="1" style="width: 100%; border-collapse: collapse;"> <tr><td style="width: 20px; height: 20px;"></td></tr> </table> <p>0 Unknown, not applicable (fault not present, intermittent or disappeared) 1 Software error 2 Readjustment 3 Electrical repair (wiring, solder joint, etc.) 4 Mechanical repair (polishing, filing, remachining, etc.) 5 Replacement (of transistor, resistor, etc.) 6 Cleaning and/or lubrication 7 Operator error 8 Missing items (on pre-sale test) 9 Environmental requirements are not met</p>	

⑦ Job completed: Enter a cross when the job has been completed.

⑧ Working time: Enter the total number of working hours spent in connection with the job (excluding travelling, waiting time, etc.), using the last box for tenths of hours.

	1	2
--	---	---

 = 1,2 working hours (1 h 12 min.)

Sales and service all over the world

Alger: Bureau de Liaison Philips,
24 bis Rue Bougainville,
El Mouradia, Alger; tel. 565672

Argentina: Philips Argentina S.A.,
Cassila de Correo 3479, (Central), 1430 Buenos Aires;
tel. (1) 70-12421/70-2325/2905/6488

Australia: Philips Scientific & Industrial
Equipment Division, Centre Court,
25 - 27 Paul Street, P.O. Box 119,
North Ryde/NSW 2113; tel. (2) 888-8222

Bangla Desh: Philips Bangla Desh Ltd.,
P.O. Box 62; Ramna, Dacca; tel. 283332

België/Belgique: Philips and MBLE associates,
Philips Scientific and Industrial Equipment Division;
80 Rue des Deux Gares; 1070 Bruxelles,
tel. (2) 523.00.00

Bolivia: Industrias Bolivianas Philips S.A.,
Cajón Postal 2964, La Paz;
tel.: 50029/55270/55604

Brasil: Philips Do Brasil Ltda,
Avenida 9 de Julho 5229; Caixa Postal 8681;
CEP 01407 - Sao Paulo (S.P.);
tel. 2825722

Service Centre:
Sistemas Profissionais
Rua Amador Bueno, 474,
Caixa Postal 3159 - S. Amaro
CEP 04752 - Sto Amara (S.P.);
tel. (11) 2476522

Canada: Philips Test and Measuring Instruments Inc.,
6 Leswyn Road,
Toronto (Ontario) M6A-1K2;
tel. (416) 789-7188

Chile: Philips Chilena S.A.,
Division Profesional, Avda. Santa Maria 0760;
Casilla Postal 2687, Santiago de Chile; tel. 770038

Colombia: Industrias Philips de Columbia S.A.,
Calle 13 no. 51-39, Apartado Aereo 4282,
Bogota; tel. 2600600

Danmark: Philips Elektronik-Systemer A/S,
Afd. for Industri og Forskning; Strandlodsvvej 4,
P.O. Box 1919, 2300 København S,
tel. (1) 572222

Deutschland (Bundesrepublik): Philips GmbH,
Unternehmensbereich Elektronik für
Wissenschaft und Industrie, Miramstrasse 87,
Postfach 310 320; 35 Kassel-Bettenhausen;
tel. (561) 5010

Ecuador: Philips Ecuador S.A.,
Casilla 343, Quito; tel. 239080

Egypt: Resident Delegate Office of Philips Industries,
5 Sherif Street, Corner Eloufi, P.O. Box 1687, Cairo;
tel. 754118/754259/754077.

Eire: Philips Electrical (Ireland) Ltd.
Newstead, Clonskeagh, Dublin 14; tel. (1) 693355

España: Philips Ibérica S.A.E.,
Dpto Aparatos de Medida, Martinez Villergas 2,
Apartado 2065, Madrid 27;
tel. (1) 4042200

Service Centre:
Dpto Tco. de Instrumentación,
Calle de Albasanz 75, Madrid 17;
tel. (1) 2047100

Ethiopia: Philips Ethiopia (Priv. Ltd. Co.),
Ras Abebe Areguay Avenue,
P.O.B. 2565,
Addis Ababa; tel. 448300

Finland: See Suomi

France: S.A. Philips Industrielle et Commerciale,
Division S&I,
105 Rue de Paris, 93 002 Bobigny;
tel. (1) 8301111

Great Britain: Pye Unicam Ltd., York Street,
Cambridge CB1-2PX, tel. (223) 358866
Service Centre:
Beddington Lane, Croydon, Surrey CR9-4EN;
tel. (1) 6843670.

Greece: See Hellas

Hellas: Philips S.A. Hellénique,
54 Avenue Syngrou, P.O. Box 153,
Athens 403; tel. (1) 9215311

Hong Kong: Philips Hong Kong Ltd.,
P.O.B. 2108, St. George's Building, 21st floor,
Hong Kong city; tel. (5) 249246

Service Centre:
Hopewell Centre, 16th floor,
No. 17, Kennedy Road,
Wanchai, Hong Kong;
tel. (5) 283575

India: Peico Electronics & Electricals Ltd.,
S&I Equipment, Shivsagar Estate,
Block "A", Dr. Annie Besant Road,
P.O.B. 6598, Worli, Bombay 4000 18 (WB);
tel. 391431

Indonesia: P.T. Philips Development Corporation,
Jalan Let. Jen Haryone M.T. Kav. 17,
P.O.B. 2287, Jakarta-Selatan; tel. (21) 820808

Iran: Philips Iran Ltd., P.O.B. 1297, Teheran;
tel. 662281/5

Iraq: Philips Iraq W.L.L., Munir Abbas Building,
4th floor; South Gate, P.O. box 5749, Baghdad;
tel. 8880409

Island: Heimilsteaki SF, Saetún 8, Reykjavik;
tel. 24000

Islas Canarias: Philips Ibérica S.A.E.,
Triana 132, Las Palmas, Casilla 39-41,
Santa Cruz de Tenerife

Italia: Philips S.p.A., Sezione S&I/T&M;
Viale Elvezia 2, 20052 Monza; tel. (39) 36351

Japan: See Nippon

Jordan: Philips Delegate Office,
P.O. Box 35268, Amman; tel. 43998

Kenya: Philips (Kenya) Ltd.,
01 Kalou Road, Industrial Area,
P.O.B. 30554, Nairobi; tel. 557999

Kuwait: Delegate Office of Philips Industries,
P.O. Box 3801, Safat, Kuwait; tel. 428678

Lebanon: Philips Middle East S.A.R.L.;
P.O. Box 11670, Beirut, tel. 382300

Malaysia: Philips Malaysia Sdn Bhd.,
Lot 2, Jalan 222, Section 14,
P.O. Box 2163, Petaling Jaya,
Selangor; tel. 574411

México: Philips Mexicana S.A. de C.V.,
Div. Científico Industrial, Calle Durango 167,
Apartado Postal 24-328, Mexico 7 (D.F.);
tel. 544-91-99

Morocco: S.A.M.T.E.L., Casa Bandoeng,
B.P. 10896, Casablanca; tel. 303192

Nederland: Philips Nederland B.V.,
Hoofdgroep PPS, Boschdijk 525, Gebouw VB,
5600 VB Eindhoven; tel. 793333

Service centre:
Technische Service Prof. Aktiviteiten
Hurkstrat 42, Gebouw HBK,
5600 MC Eindhoven; tel. 723094

Ned. Antillen: Philips Antillana N.V.,
Postbus 523, Willemstad, Curaçao;
tel. 37575/37475

New Zealand: Philips Electrical Industries of N.Z. Ltd.,
Scientific and Industrial Equipment Division;
Horlor Street, P.O. Box 2097,
Naenae, Wellington; tel. 678639

Nigeria: Associated Electronic Products (Nigeria) Ltd.,
Ikroodu Road, P.O.B. 1921, Lagos; tel. 900160/61

Nippon: NF Trading Co. Ltd.,
Kirimoto Bldg. 11-2,
Tsunashima Higashi 1 - Chome, Kohoku-ku,
Yokohama

Norge: Norsk A.S. Philips,
Industri og Forskning, Essendrops gate 5,
Postboks 5040, Oslo 3; tel. (2) 463890
Service Centre:
Postboks 1 Manglerud, Oslo 6; tel. (2) 336270

Oesterreich: Oesterreichische Philips Industrie GmbH,
Abteilung Industrie Elektronik,
Breitenfurterstrasse 219, A-1230 Wien;
tel. (222)-841611/15.

Pakistan: Philips Electrical Co. of Pakistan Ltd.,
El-Markz, M.A. Jinnach Road, P.O.B. 7101,
Karachi 3; tel. 70071

Paraguay: Philips del Paraguay S.A.,
Casilla de Correo 605, Asunción;
tel. 48045/46919

Perú: Philips Peruana S.A.,
Av. Alfonso Ugarte 1268
Apartado Aereo 1841, Lima 100, tel. 326070

Philippines: Philips Industrial Development Inc.,
2246 Pason Tamo, P.O.B. 911,
Makati Rizal, 3116, Manila; tel. 868951/868959

Portugal: Philips Portuguesa S.A.R.L.,
Av. Eng. Duarte Pacheco 6, Apartado 1331, Lisboa 1000;
tel. (19) 683121/9

Service Centre:
Servicos Técnicos Profissionais, Outurela,
2795 Linda-a-Velha; tel. (19) 2180071

Saudi Arabia: Delegate Office Philips Industries,
Sabreen Bldg., Airport Road, P.O. Box 9844,
Riyadh; tel. 4777808/4778463

Schweiz-Suisse-Svizzera: Philips A.G.,
Allmendstrasse 140, Postfach, CH-8027 Zürich;
tel. (1) 4882211/4882629

Singapore: Philips Singapore Private Ltd.,
Lorong 1, Tao Payoh, 1st floor,
P.O. Box 340, Toa Payoh Central Post Office,
Singapore 1231; tel. (2) 538811
Service Centre:
403 Delta House, 4th floor,
No. 2 Alexandra Road,
Singapore 0315; tel. 2712555

South Africa: South African Philips (Pty) Ltd.,
2 Herb Street, New Doornfontein, P.O.B. 7703,
Johannesburg 2000; tel. (11) 6140411

South-Korea: Philips Electronics (Korea) Ltd.,
P.O. Box 3680, Seoul; tel. 794 4202

Suomi: Oy Philips Ab.,
Kalvokatu 8,
P.O. Box 10255,
00101 Helsinki 10; tel. 17271
Service Centre:
P.O. Box 11, SF-02631 Espoo 63;
tel. (0) 523122

Sverige: Svenska A.B. Philips,
Philips Industri Elektronik, Lidingövägen 50,
Fack, S11584 Stockholm; tel. (8) 635000

Syria: Philips Moyen-Orient S.A., Rue Fardoss 79,
Immeuble Kassar and Sadate, B.P. 2442, Damas,
tel. 118605/221650/228003

Taiwan: Philips Taiwan Ltd.,
San Min Building, P.O. Box 22978, Taipei;
tel. (2) 5631717

Tanzania: Philips (Tanzania) Ltd.,
Box. 20104, Dar es Salaam; tel. 29571/4

Thailand: Philips Electrical Co. of Thailand Ltd.,
283 Silom Road, P.O. Box 961, Bangkok 5;
tel. 233-6330/9

Tunisia: S.T.I.E.T., 32 bis, Rue Ben Ghedham,
Tunis; tel. 244268/243025

Türkiye: Türk Philips Ticaret A.S.,
Posta Kutusu 504, Bevoglu,
Istanbul 1; tel. 435910

United Arab Emirates: Philips Delegate Office,
P.O. Box 2567, Dubai; tel. 220641/220642

Uruguay: Industrias Philips del Uruguay S.A.,
Avda Uruguay 1287, Casilla de Correo 294,
Montevideo; tel. 915641/44

U.S.A.:
Philips Test and Measuring Instruments Inc.,
California, Garden Grove 92645
12882 Valley View Street, Suite 9;
tel. : (213) 594-8741 / (714) 898-5000
California, Milpitas 95035
489 Valley Way;
tel. (408) 946-6722
Florida, Orlando 32805
750 S Orange Blossom Trail, Suite 206;
tel. (305) 422-8131
Georgia, Norcross 30071
7094 Peachtree Industrial Blvd., Suite 220;
tel. (404) 586-0238
Illinois, Elk Grove Village 60007
175 Scott Street;
tel. (312) 640-7860
Massachusetts, Woburn 01801
21 Olympia Avenue;
tel. (617) 935-3972
Minnesota, Minneapolis 55420
7801 Metro Parkway, Suite 109;
tel. (612) 854-2426
New Jersey, Mahwah 07430
85 McKee Drive;
tel. (201) 529-3800, Toll-free (800) 631-7172

Venezuela: Industrias Venezolanas Philips S.A.,
Apartado Aereo 1167, Caracas 107;
tel. (2) 393811/353533

Zaire: S.A.M.E./S.Z.A.R.L., B.P. 16636, Kinshasa,
tel. 31887/8

Zambia: Philips Electrical Zambia Ltd.,
Mweneshi Road, P.O.B. 31878, Lusaka;
tel. 218511/218701

Zimbabwe: Philips Electrical (PVT) Ltd.,
62, Untali Road, P.O. Box 994, Beverley/Salisbury;
tel. 47211

For information on change of address:
N.V. Philips' Gloeilampenfabrieken,
Test and Measuring Instruments, Building TQ III-4,
5600 MD Eindhoven - The Netherlands

For countries not listed:
N.V. Philips' Gloeilampenfabrieken, S&I Export;
Test and Measuring Instruments, Building TQII-3,
5600 MD Eindhoven - The Netherlands



PHILIPS

SERVICE	Scientific & Analytical Equipment
	Test & Measuring Instruments
	Industrial Automation
	Advanced Automation Systems
	Welding

**Scientific &
Industrial
Equipment
Division**

820607

PM2521/22

SME94

Already issued : SME93
Re : Service documentation for the battery power supply

The service manual of the PM2521 together with this information sheet comprise the service manual for the PM2521/22.

CONTENTS

1. CIRCUIT DESCRIPTION

- 1.1. General
- 1.2. Charging circuit
- 1.3. Level convertors
- 1.4. Schmitt trigger

2. ACCESS

3. FAULT-FINDING

4. CHECKING AND ADJUSTING

5. PARTS LIST

- 5.1. Resistors
- 5.2. Capacitors
- 5.3. Semiconductors
- 5.4. Integrated circuits
- 5.5. Miscellaneous

6. CIRCUIT DIAGRAMS

9499 478 12511

PRINTED IN THE NETHERLANDS

1. CIRCUIT DESCRIPTION

1.1. GENERAL

The PM2521/22 version is a standard PM2521 that includes a built-in battery power supply.

The battery power supply part consists of one Pb cell and a circuit that converts the battery voltage into +5V, +13V and -13V.

The circuit of the battery power supply can be subdivided into three main parts:

- Charging circuit
- Two level converters
- Schmitt trigger

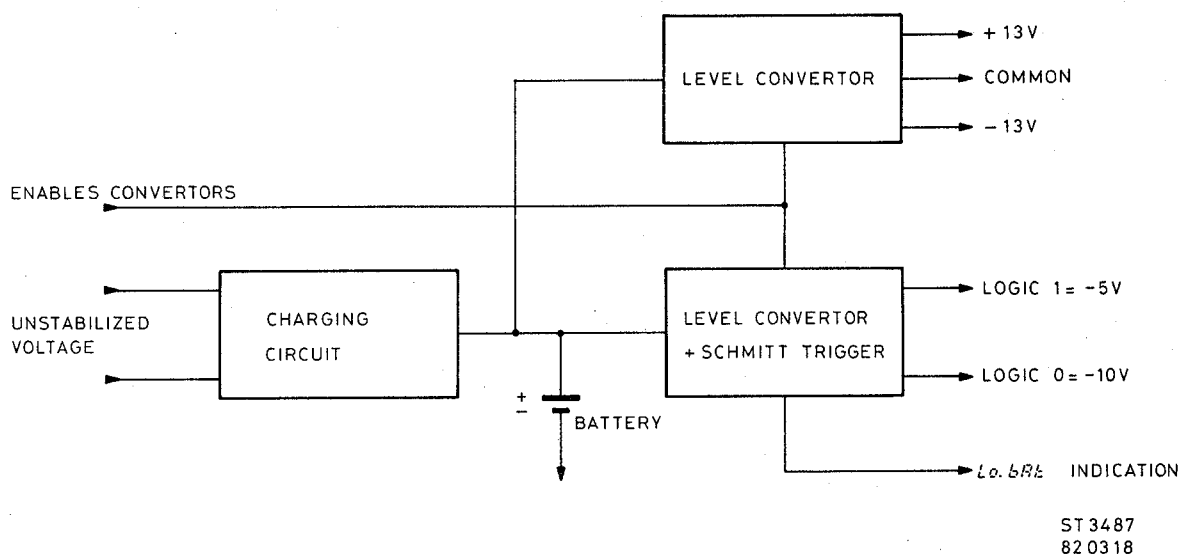

Fig. 1. Block diagram-battery power supply

1.2. CHARGING CIRCUIT (refer to the overall circuit Fig. 6.).

If the battery is charged, by the power supply (power switch in position "OFF", PM2521 connected to the mains) the voltage on point 2 of X101 is stabilized by A101. The output voltage of A101 is the charging voltage for the battery.

When the temperature changes, the output voltage is compensated by V101, so the required charging voltage is always available.

In the position "OFF" the converters are disabled by means of two diodes V202 and V203. By this means, the battery is prevented from discharging via the converters.

1.3. LEVEL CONVERTORS

When the battery is being discharged, (power switch in position "ON", PM2521 disconnected from the mains) the battery voltage is supplied to V501. Due to this the circuit which is made by T501, A401 (Q3), R502 begins to oscillate. This oscillation produces a positive voltage (+13V) on point 3 of X101 and a negative voltage (-13V) on point 6 of X101 (with respect to pin 4 of X101).

The centre pin of T501 is fed to the base of Q1 (A401) and this provides a base current for V401 and V402. The result is a voltage of +5V on pin 5 of X101 (with respect to pin 8 of X101).

1.4. SCHMITT TRIGGER

The Schmitt trigger circuit consists of two transistors Q4 and Q5 (A401).

When the voltage of the battery drops below 5,5V, the Schmitt trigger switches the output (pin 7 of X101) from +5V to 0V (with respect to pin 8 of X101).

2 ACCESS

Dismantling the battery power supply:

- Remove the top cover as described in Chapter 2 of the PM2521 Service Manual.
- Disconnect the connector X101. (Fig. 2, item 1.).
- Remove the two screws from the battery power supply cover. (Fig. 2, item 2.).
- Lever up the cover and remove it.
- Remove the two screws. (Fig. 2, item 3.).
- The battery and the printed-circuit board can now be removed.

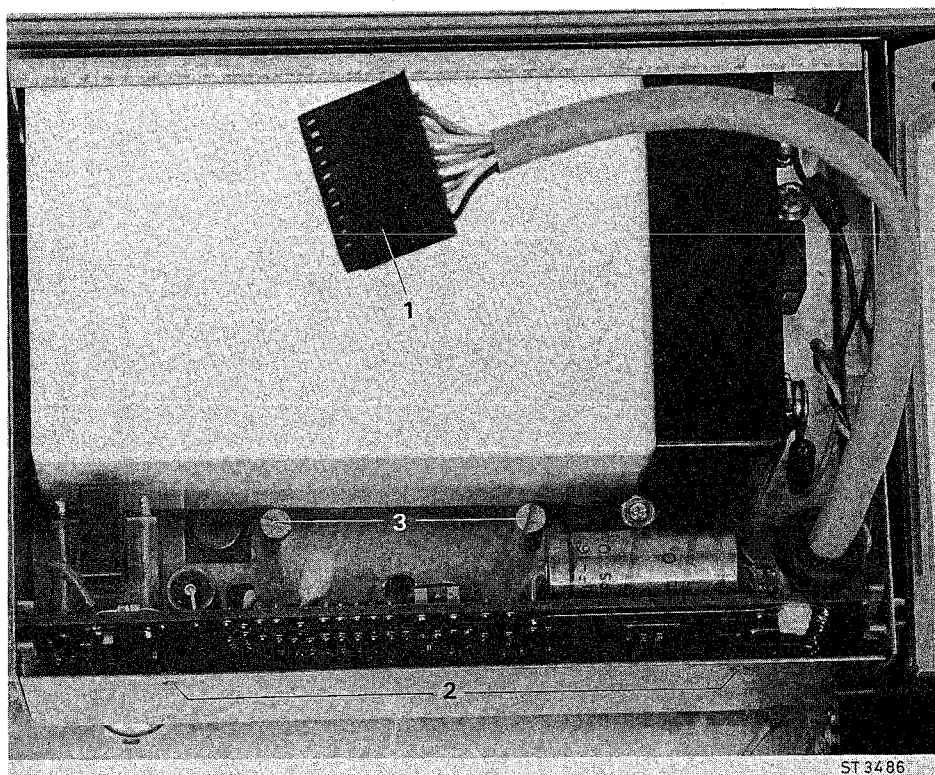
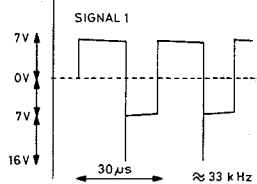
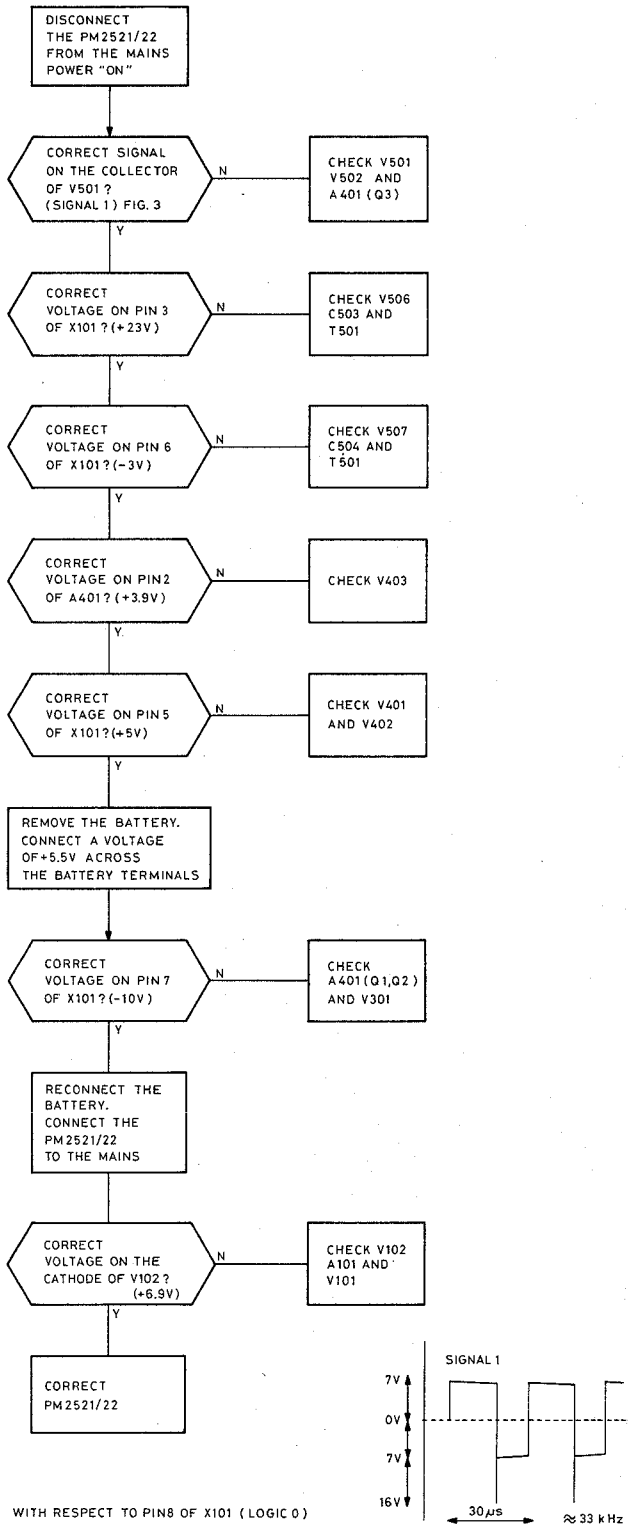

Fig. 2. Dismantling the battery power supply

3. FAULT-FINDING

The following flow-chart offers a simple method of locating faults in the PM2521/22.



ST3488
82 05 12

Fig. 3. Waveform-collector V501

4. CHECKING AND ADJUSTING

- Disconnect the battery power supply from the PM2521/22.
- Remove the battery.
- In its place, fit a $1k\Omega$ resistor across the battery terminals of the power supply unit.
- Connect a voltage of +10V (20mA) across points 10 (+) and 8 (-) of the printed-circuit board.
- With preset R105, adjust the voltage across the external $1k\Omega$ resistor to 6,9V.
- Remove the $1k\Omega$ resistor and connect a voltage of +7V (1A) between the battery terminals (red=+).
Fit the connector X101 of the battery unit to X101 of the PM2521/22.
- Switch on the PM2521 and adjust the voltage between points 5 (+) and 8 (-) to +5,0V.
- Connect a voltage of 5,5V across the battery terminals.
With preset R301, adjust the voltage on point 14 of A401 so that the voltage goes from -5V to -10V (not reverse).
- Remove the voltage from the battery terminals and refit the battery.
- Check the discharge current ($\approx 700mA$).
- Check the voltage across C503 is between +12V and +15,5V.
- Check the voltage across C504 is between -12V and -15,5V.
- Connect the PM2521/22 to the mains and check the charging current is between 5mA and 400mA.

5. PARTS LIST

5.1. RESISTORS

<i>Ordering number</i>	<i>Value (Ω)</i>	<i>Tol. (%)</i>	<i>Item</i>
5322 116 55615	20	5%	R101
5322 116 55614	6,49	0,5%	R102
5322 116 55614	6,49	0,5%	R103
5322 116 54502	216	1%	R104
4822 100 10019	220	20%	R105
5322 116 54541	825	1%	R106
5322 116 54696	100K	1%	R201
4822 100 10029	2K2	20%	R301
4822 116 51253	10K	1%	R302
5322 116 50729	4K22	1%	R303
5322 116 54696	100K	1%	R304
4822 116 51253	10K	1%	R305
4822 116 51253	10K	1%	R306
5322 116 54651	26K1	1%	R401
5322 116 50506	154	1%	R402
5322 116 50608	6K19	1%	R403
5322 116 50593	16K2	1%	R404
4822 100 10036	4K7	1%	R405
5322 116 54597	5K36	1%	R406
5322 116 50536	464	1%	R501
5322 116 54632	14K7	1%	R502

5.2. CAPACITORS

<i>Ordering number</i>	<i>Value (F)</i>	<i>Tol. (%)</i>	<i>V</i>	<i>Item</i>
4822 124 20777	1000 μ	-10+50	16	C101
4822 124 20977	15 μ	20	16	C201
4822 124 10204	2,2 μ	20	16	C401
4822 124 20945	33 μ	20	10	C402
4822 124 20679	100 μ	-10+50	10	C501
4822 122 31439	270 P	2	100	C502
4822 124 20699	47 μ	-10+50	25	C503
4822 124 20699	47 μ	-10+50	25	C504

5.3. SEMICONDUCTORS

<i>Ordering number</i>	<i>Description</i>	<i>Item</i>
4822 130 31248	BZV46-C2V0	V101
4822 130 30195	BYX10 RECT	V102
4822 130 30195	BYX10 RECT	V201
4822 130 30613	BAW62	V202
4822 130 30613	BAW62	V203
4822 130 44568	BC557B	V301
4822 130 40824	BD140	V401
4822 130 44568	BC557B	V402
5322 130 34916	BZX79-C3V9	V403
5322 130 44593	BC369	V501
4822 130 30613	BAW62	V502
4822 130 34398	BZX79-C24	V503
4822 130 30613	BAW62	V504
4822 130 30613	BAW62	V505
5322 130 34605	BAX12A	V506
5322 130 34605	BAX12A	V507

5.4. INTEGRATED CIRCUITS

<i>Ordering number</i>	<i>Description</i>	<i>Item</i>
4822 209 80591	LM317T VOLT REG NS	A101
5322 209 84111	CA3086	A401

5.5. MISCELLANEOUS

<i>Ordering number</i>	<i>Description</i>	<i>Item</i>
5322 148 84061	TRAFO TFU15	T501
4822 253 20018	FUSE 1A FAST	F101
5322 158 10052	HF CHOKE 38W-band	L501
5322 158 10052	HF CHOKE 38W-band	L502

6. CIRCUIT DIAGRAMS

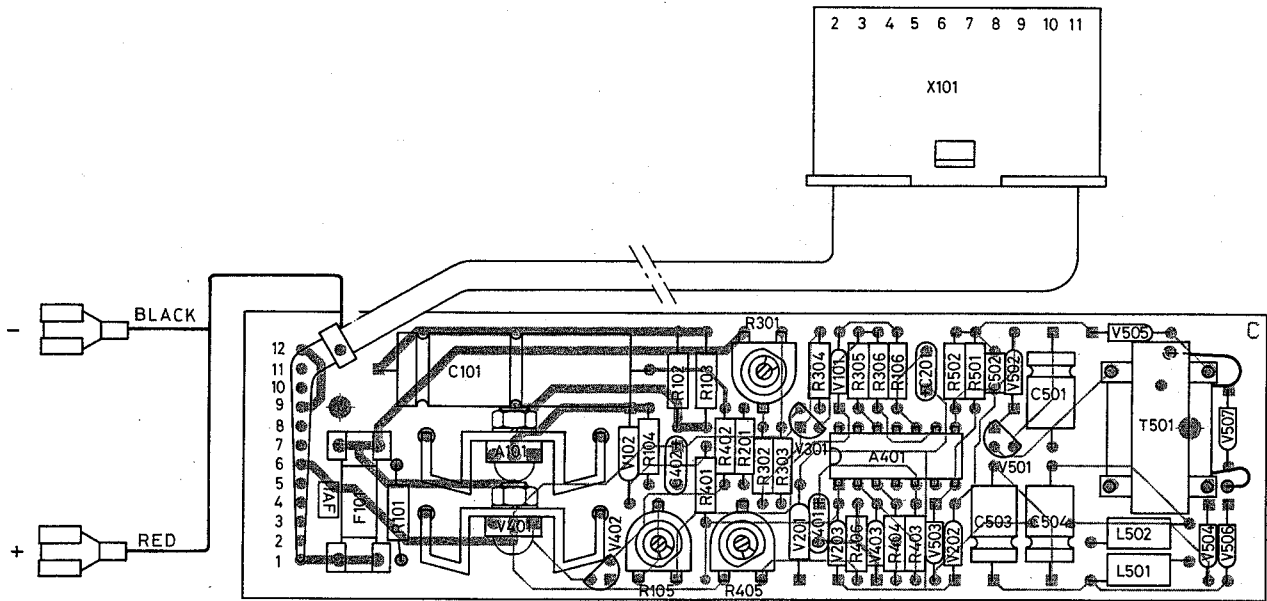

Fig. 4. Main p.c.b. lay-out, component side

RD 3468
82 05 07

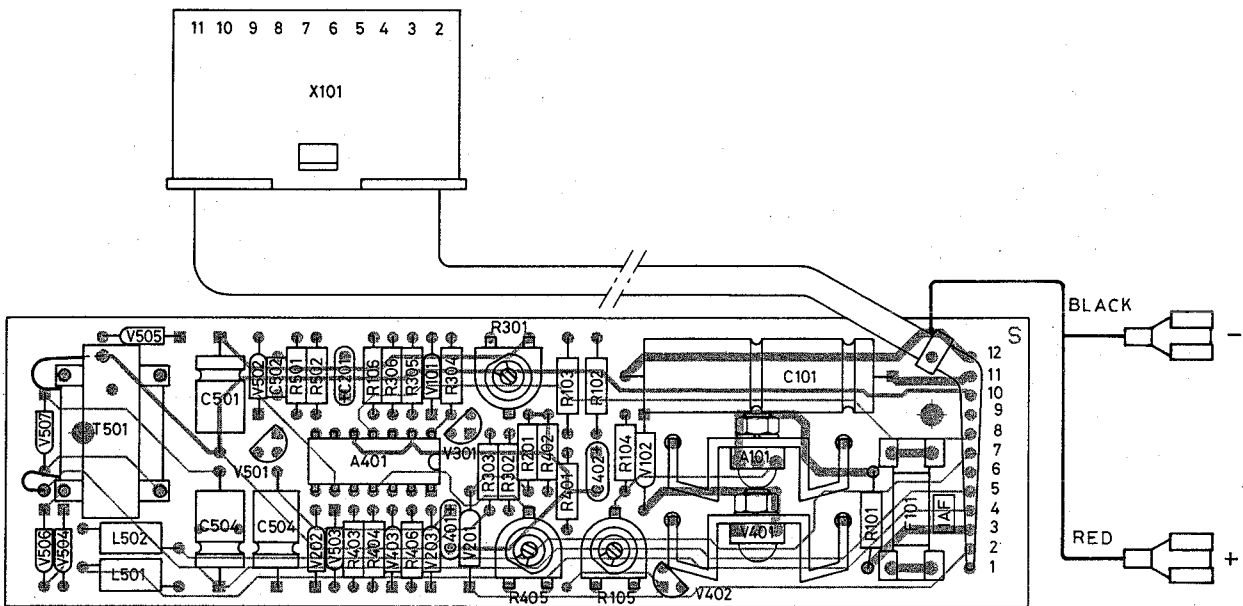
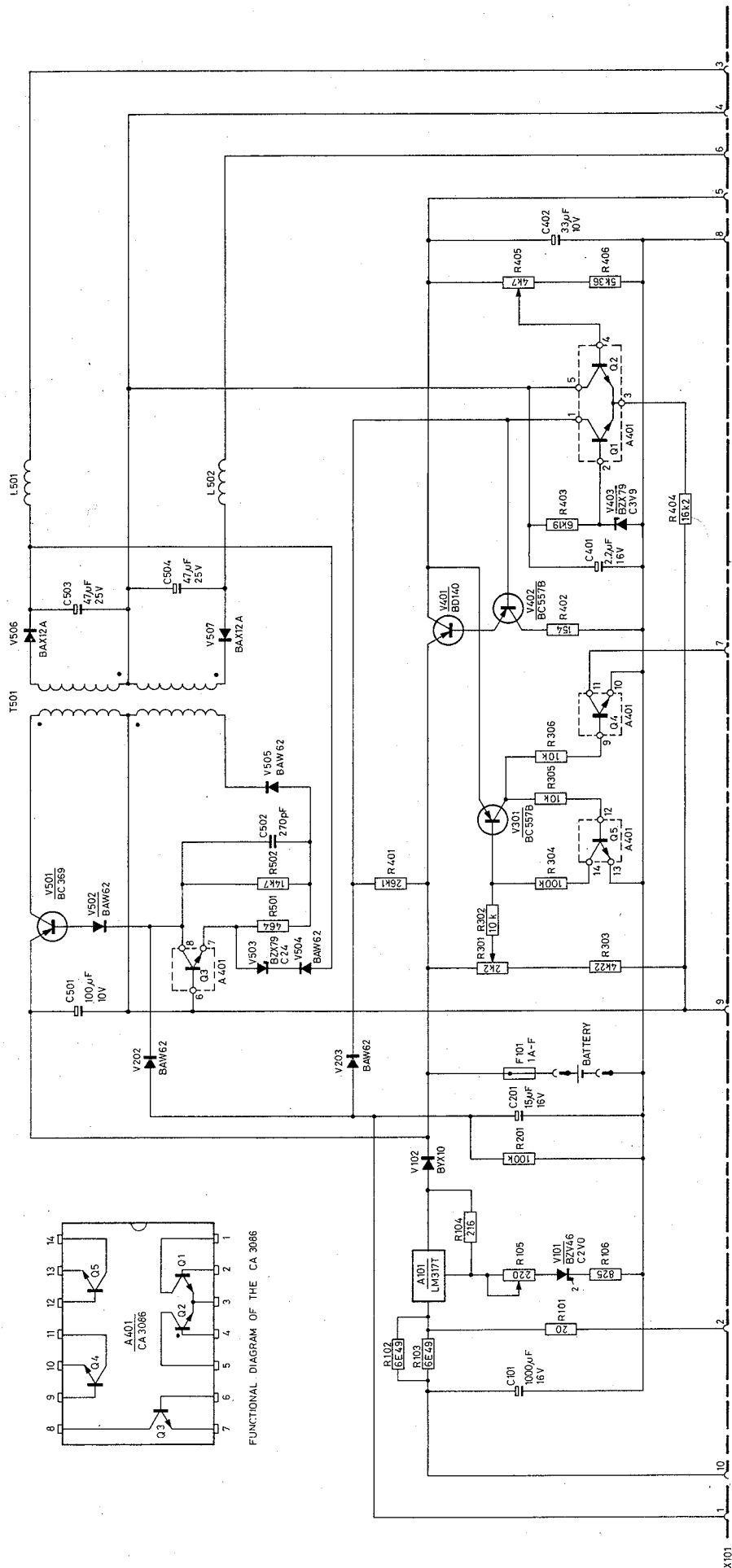

Fig. 5. Main p.c.b. lay-out, conductor side

ST 3469
82 05 07



ST 3467
81.05.07

Fig. 6. Circuit diagram

X101



PHILIPS

SERVICE

Cryogenic Equipment / Electro Chemistry /
Electron Optics / Electronic Weighing /
Industrial Data Systems / Numerical Control /
Philips Pollution Measuring / Radiation Measuring Equipment /
Test and Measuring Equipment / Welding Equipment /
X-Ray Analytical Equipment

equipment for science and industry

811110

PM 2521

SME 90

Already issued : —
Re : Erratum of the technical data

This erratum gives the complete specification of:

- Alternating voltage measurements (section 2.1.2.)
- Alternating current measurements (section 2.1.4.)
- dB measurements (section 2.1.5.) and
- Counter measurements (section 2.1.9.)

By this information, the given specification in the mentioned sections of the operating manual (9499 470 15901) are no longer valid.

2.1.2. Alternating voltage measurements

Ranges

mV	200
V	2 20 200 2000

Maximum input voltage in range 2000 V

600 V

Resolution

10 μ V in range 200 mV

Measured value less than 0,5 % of range is displayed as zero

Number of representation units

21000

Accuracy

(valid between 3 % and 100 % of range)

Range 200 mV up to and including 200 V	
40 Hz - 500 Hz	\pm (0,3 % of reading + 0.15 % of range)
at 20 kHz	\pm (1 % of reading + 0.15 % of range)
at 100 kHz	\pm (5 % of reading + 1 % of range)

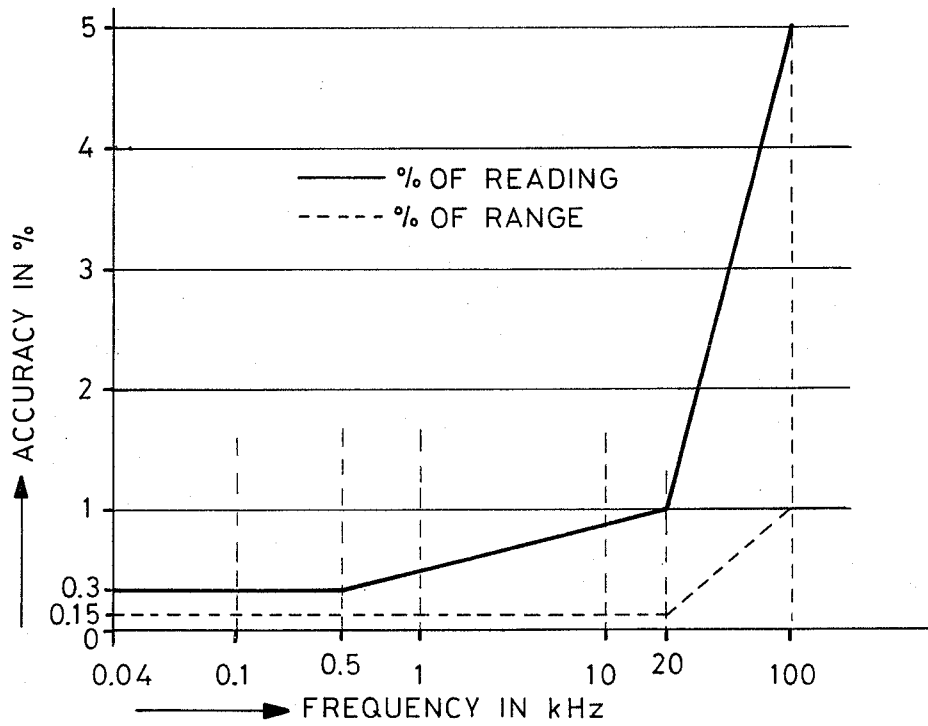

ST 3354

Range 2000 V	
40 Hz - 60 Hz	$\pm (0.3 \% \text{ of reading} + 0.15 \% \text{ of range})$

$\pm (0.03 \% \text{ of reading } / ^\circ\text{C} + 0.01 \% \text{ of range } / ^\circ\text{C})$

Temperature coefficient

Input impedance

Range	Input impedance
200 mV 2 V	20 M Ω /60 pF
20 V	11 M Ω /85 pF
200 V 2000 V	10 M Ω /95 pF

Common Mode Rejection Ratio (CMRR)

100 dB for dc signals
80 dB for ac signals 50 Hz or 60 Hz $\pm 1\%$

AC detector

RMS convertor, ac coupled

Crest factor

2 at range end

Response time

1.5 s without ranging
3 s including ranging

Maximum input voltage

In all ranges:
 Between Hi and Lo 600 V rms
 Between Hi and earth 1000 V rms
 Between Lo and earth 400 V rms
 Maximum dc voltage 400 V
 Maximum VHz product 10^7

2.1.4. Alternating current measurements

Ranges

μA	2	20	200
mA	2	20	200
A	2	20	

Maximum input current in range 20 A

10 A

Resolution

1 nA in range 2 μA

Measured value less than 0.5 % of range is displayed as zero

Number of representation units

2100

Accuracy

40 Hz - 200 Hz \pm (0.4 % of reading + 0.15 % of range)

(valid between 3 % and 100 % of range)

Temperature coefficient

\pm (0.03 % of reading / $^{\circ}\text{C}$ + 0.01 of range / $^{\circ}\text{C}$)

Voltage drop over shunt

Range	Voltage drop	Frequency
2 μA 20 μA 200 μA 2 mA	< 2.5 mV	50 Hz
20 mA 200 mA	< 25 mV	
2 A 20 A	< 250 mV	

AC detector

RMS convertor, ac coupled

Crest factor

2 at range end

Response time

1 s without ranging

3 s including ranging

Protection

Range 2 μA - 20 mA; 250 V rms

Range 200 mA - 20 A are not protected

$I_{\text{max.}} = 20 \text{ A}$ for 20 seconds

Maximum Common Mode voltage

400 V rms, 560 V peak

Maximum input voltage

In all ranges:

Between Hi and Lo 250 V rms

Between Hi and earth 400 V rms

Between Lo and earth 400 V rms

2.1.5. dB measurements (valid in function $V_{\sim \text{rms}}$)

Range

-57,7 dB ... +57,7 dB

0 dB reference

1 mW in 600 Ω , 0.775 V or when selecting the relative reference function with pushbutton ZERO SET at the front of the PM 2521

Resolution

0.1 dB

Measured value less than -57.7 dB is displayed as -99.9 dB

Number of representation units

999

Accuracy

Signals	Frequency	Accuracy
-31,7 dB ... +47 dB	40 Hz - 20 kHz 20 kHz - 100 kHz	\pm 0.2 dB \pm 1 dB
-50 dB ... -31,7 dB	40 Hz - 20 kHz	\pm 2 dB
-57,7 dB ... -50 dB	40 Hz - 20 kHz	\pm 3 dB
> +47 dB	40 Hz - 500 Hz	\pm 1,5 dB

Temperature coefficient

0.02 dB/°C

Signals	Impedance
0 V - 1.8 V	20 M Ω //60 pF
1.8 V - 18 V	11 M Ω //85 pF
18 V - 600 V	10 M Ω //95 pF

Common Mode Rejection Ratio (CMRR)

100 dB for dc signals
80 dB ac signals 50 Hz or 60 Hz \pm 1 %

AC detector

RMS convertor, ac coupled

Crest factor

2 at range end

Response time

3 s

Relative reference setting

With pushbutton ZERO SET at the front of the PM 2521

Maximum input voltages

In all ranges:

Between Hi and Lo 600 V rms

Between Hi and earth 1000 V rms

Between Lo and earth 400 V rms

Maximum dc voltage 400 V

Maximum VHz product 10^7 **2.1.9. Counter measurements (Hz)**

Ranges

kHz	10	100
MHz	1	10

Range selection

Range 100 kHz, 1 MHz and 10 MHz; Manual or automatic
Range 10 kHz; Manual only

Resolution

0.1 Hz in range 10 kHz

Number of representation units

99999

Accuracy for counter measurements

Range	Accuracy
10 kHz	\pm (0.005 % of reading + 0.001 % of range)
100 kHz	
1 MHz	
10 MHz	\pm (0.01 % of reading + 0.001 % of range)

Gate time

Range	Gate time
10 kHz	10 s
100 kHz	1 s
1 MHz	100 ms
10 MHz	10 ms

Conversion rate

Range	Rate
10 kHz	1 conv./10 s
100 kHz	1 conv./s
1 MHz	
10 MHz	

Trigger mode

On positive going crossings of the + trigger level
On negative going crossings of the - trigger level

Counter sensitivity

DC to 1 MHz 150 mV peak

1 MHz to 10 MHz 300 mV peak

Resolution 1 mV

Trigger level adjustment

With thumbwheel at the front of the PM 2521

Bereits veröffentlicht : —
 Betrifft : Erratum for Technische Daten

Dieses Korrekturblatt enthält die vollständige technische Beschreibung von:

Wechselspannungsmessungen (Abschnitt 2.1.2.)
 Wechselstrommessungen (Abschnitt 2.1.4.)
 dB-Messungen (Abschnitt 2.1.5.) und
 Zählermessungen (Abschnitt 2.1.9.)

Hierdurch werden die Angaben in den genannten Abschnitten der Bedienungsanleitung 9499 470 15901 ungültig.

2.1.2. Wechselspannungsmessungen

Bereiche

mV	200
V	2 - 20 - 200 - 2000

Maximale Eingangsspannung im 2000 V Bereich 600 V

Auflösung 10 μ V im 200 mV Bereich
 Gemessener Wert kleiner als 0,5% des Bereichs wird als Null angezeigt.

Anzahl der Anzeigeeinheiten 21000

Fehlergrenze
 (geltend zwischen 3 % und 100 % des Bereichs)

Bereich 200 mV bis einschliesslich 200 V	
40 Hz - 500 Hz	\pm (0,3 % der Ablesung + 0,15 % des Bereichs)
bei 20 kHz	\pm (1 % der Ablesung + 0,15 % des Bereichs)
bei 100 kHz	\pm (5 % der Ablesung + 1 % des Bereichs)

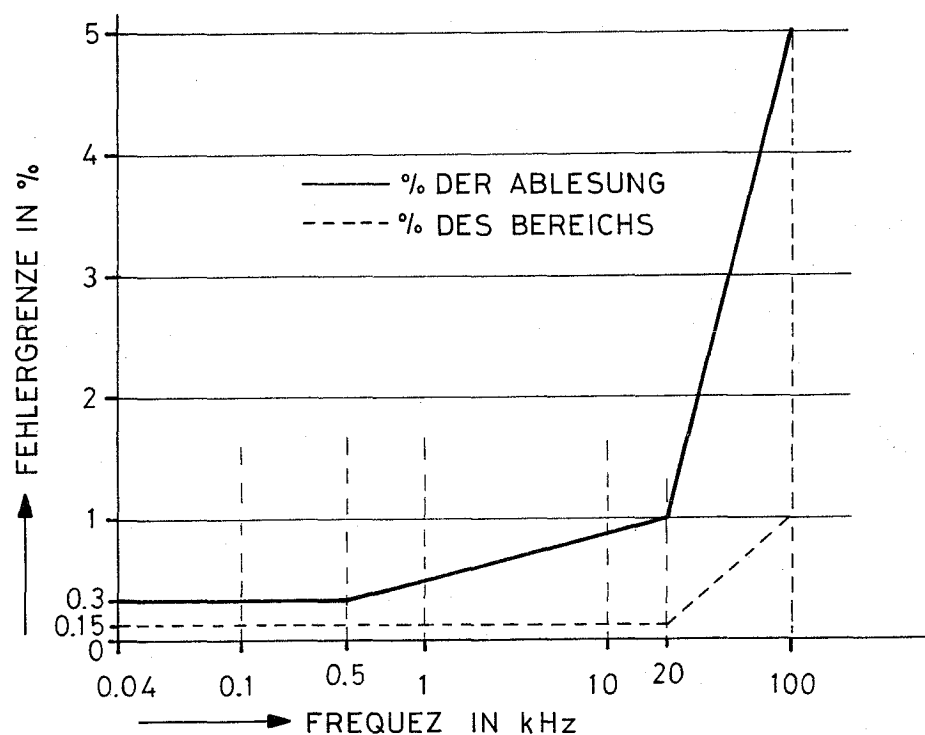

ST 3355

2000 V Bereich	
40 Hz - 60 Hz	$\pm (0,3 \% \text{ der Ablesung} + 0,15 \% \text{ des Bereichs})$

Temperaturkoeffizient

 $\pm (0,03 \% \text{ der Ablesung} / ^\circ\text{C} + 0,01 \% \text{ des Bereichs} / ^\circ\text{C})$

Eingangsimpedanz

Bereich	Eingangsimpedanz
200 mV 2 V	20 M Ω //60 pF
20 V	11 M Ω //85 pF
200 V 2000 V	11 M Ω //95 pF

Gleichtaktunterdrückung (CMRR)

100 dB für Gleichspannungssignale
80 dB für Wechselspannungssignale 50 oder 60 Hz $\pm 1 \%$

Wechselspannungsdetektor

Effektivwertkonverter, wechselspannungsgekoppelt.

Scheitelfaktor

2 bei Bereichsende

Ansprechzeit

1,5 s ohne Bereichsumschaltung
3 s einschliesslich Bereichsumschaltung

Maximale Eingangsspannungen

In allen Bereichen:
Zwischen Hi und Lo 600 V_{eff}
Zwischen Hi und Erde 1000 V_{eff}
Zwischen Lo und Erde 400 V_{eff}
Maximale Gleichspannung 400 V
Maximales VHz-Produkt 10⁷**2.1.4. Wechselstrommessungen**

Bereiche

μA	2 20 200
mA	2 20 200
A	2 20

Maximaler Eingangsstrom im 20 A Bereich

10 A

Auflösung

1 nA im 2 μA Bereich
Gemessener Wert kleiner als 0,5 % des Bereichs wird als Null angezeigt

Anzahl der Anzeigeeinheiten

2100

Fehlergrenze
(geltend zwischen 3 % und 100 % des Bereichs)40 Hz - 200 Hz $\pm (0,4 \% \text{ der Ablesung} + 0,15 \% \text{ des Bereichs})$

Temperaturkoeffizient

 $\pm (0,03 \% \text{ der Ablesung} / ^\circ\text{C} + 0,01 \% \text{ des Bereichs} / ^\circ\text{C})$

Spannungsabfall über Shunt

Bereich	Spannungsabfall	Frequenz
2 μA 20 μA 200 μA 2 mA	< 2,5 mV	50 Hz
20 mA 200 mA	< 25 mV	
2 A 20 A	< 250 mV	

Wechselspannungsdetektor

Effektivwert-Konverter, wechselspannungsgekoppelt

Scheitelfaktor

2 bei Bereichsende

Ansprechzeit

1 s ohne Bereichsumschaltung
3 s einschliesslich Bereichsumschaltung

Überlastungsschutz

Bereich $2 \mu\text{A} - 20 \text{ mA}$; $250 V_{\text{eff}}$
 Bereiche $200 \text{ mA} - 20 \text{ A}$ sind nicht geschützt
 $I_{\text{max.}} = 20 \text{ A}$ über 20 Sekunden

Maximale Gleichtaktspannung

$400 V_{\text{eff}}$, $560 V_{\text{Spitze}}$

Maximale Eingangsspannung

In allen Bereichen:
 Zwischen Hi und Lo $250 V_{\text{eff}}$
 Zwischen Hi und Erde $400 V_{\text{eff}}$
 Zwischen Lo und Erde $400 V_{\text{eff}}$

2.1.5. dB-Messungen (geltend in Funktion V~)**Bereich**

$-57,7 \text{ dB} \dots +57,7 \text{ dB}$

dB-Nullreferenz

1 mW in 600Ω $0,775 \text{ V}$ oder bei Wahl der relativen Referenzfunktion mit Drucktaste ZERO SET auf der Frontplatte des PM 2521.

Auflösung

$0,1 \text{ dB}$

Gemessener Wert kleiner als $-57,7 \text{ dB}$ wird als $-99,9 \text{ dB}$ angezeigt

Anzahl der Anzeigeeinheiten

999

Fehlergrenze

Signale	Frequenz	Genauigkeit
$-31,7 \text{ dB} \dots +47 \text{ dB}$	$40 \text{ Hz} - 20 \text{ kHz}$ $20 \text{ kHz} - 100 \text{ kHz}$	$\pm 0,2 \text{ dB}$ $\pm 1 \text{ dB}$
$-50 \text{ dB} \dots -31,7 \text{ dB}$	$40 \text{ Hz} - 20 \text{ kHz}$	$\pm 2 \text{ dB}$
$-57,7 \text{ dB} \dots -50 \text{ dB}$	$40 \text{ Hz} - 20 \text{ kHz}$	$\pm 3 \text{ dB}$
$> +47 \text{ dB}$	$40 \text{ Hz} - 500 \text{ Hz}$	$\pm 1,5 \text{ dB}$

Temperaturkoeffizient

$0,02 \text{ dB}/^\circ\text{C}$

Eingangsimpedanz

Signale	Impedanz
$0 - 1,8 \text{ V}$	$20 \text{ M}\Omega // 60 \text{ pF}$
$1,8 - 18 \text{ V}$	$11 \text{ M}\Omega // 85 \text{ pF}$
$18 - 600 \text{ V}$	$11 \text{ M}\Omega // 95 \text{ pF}$

Gleichtaktunterdrückung (CMRR)

100 dB für Gleichspannungssignale
 80 dB Wechselspannungssignale 50 Hz oder $60 \text{ Hz} \pm 1 \%$

Wechselspannungsdetektor

Effektivwert-Konverter, wechsellspannungsgekoppelt

Scheitelfaktor

2 bei Bereichsende

Ansprechzeit

3 s

Relative Referenzeinstellung

Mit Drucktaste ZERO SET auf der Frontplatte des PM 2521

Maximale Eingangsspannungen

In allen Bereichen:
 Zwischen Hi und Lo $600 V_{\text{eff}}$
 Zwischen Hi und Erde $1000 V_{\text{eff}}$
 Zwischen Lo und Erde $400 V_{\text{eff}}$

Maximale Gleichspannung 400 V
 Maximales VHz Produkt 10^7

2.1.9. Frequenzmessungen (Hz)**Bereiche**

kHz	10	100
MHz	1	10

Bereichswahl

Bereich 100 kHz , 1 MHz und 10 MHz : manuell oder automatisch
 Bereich 10 kHz : nur manuell

Auflösung	0,1 Hz im 100 kHz Bereich										
Anzahl der Anzeigeeinheiten	99999										
Fehlergrenze für Zählermessungen	<table border="1"> <thead> <tr> <th>Bereich</th> <th>Fehler</th> </tr> </thead> <tbody> <tr> <td>10 kHz 100 kHz 1 MHz</td> <td>$\pm (0,005 \% \text{ der Anzeige} + 0,001 \% \text{ des Bereichs})$</td> </tr> <tr> <td>10 MHz</td> <td>$\pm (0,01 \% \text{ der Anzeige} + 0,001 \% \text{ des Bereichs})$</td> </tr> </tbody> </table>	Bereich	Fehler	10 kHz 100 kHz 1 MHz	$\pm (0,005 \% \text{ der Anzeige} + 0,001 \% \text{ des Bereichs})$	10 MHz	$\pm (0,01 \% \text{ der Anzeige} + 0,001 \% \text{ des Bereichs})$				
Bereich	Fehler										
10 kHz 100 kHz 1 MHz	$\pm (0,005 \% \text{ der Anzeige} + 0,001 \% \text{ des Bereichs})$										
10 MHz	$\pm (0,01 \% \text{ der Anzeige} + 0,001 \% \text{ des Bereichs})$										
Torzeit	<table border="1"> <thead> <tr> <th>Bereich</th> <th>Torzeit</th> </tr> </thead> <tbody> <tr> <td>10 kHz</td> <td>10 s</td> </tr> <tr> <td>100 kHz</td> <td>1 s</td> </tr> <tr> <td>1 MHz</td> <td>100 ms</td> </tr> <tr> <td>10 MHz</td> <td>10 ms</td> </tr> </tbody> </table>	Bereich	Torzeit	10 kHz	10 s	100 kHz	1 s	1 MHz	100 ms	10 MHz	10 ms
Bereich	Torzeit										
10 kHz	10 s										
100 kHz	1 s										
1 MHz	100 ms										
10 MHz	10 ms										
Umsetzrate	<table border="1"> <thead> <tr> <th>Bereich</th> <th>Rate</th> </tr> </thead> <tbody> <tr> <td>10 kHz</td> <td>1 Um./10 s</td> </tr> <tr> <td>100 kHz 1 MHz 10 MHz</td> <td>1 Um./s</td> </tr> </tbody> </table>	Bereich	Rate	10 kHz	1 Um./10 s	100 kHz 1 MHz 10 MHz	1 Um./s				
Bereich	Rate										
10 kHz	1 Um./10 s										
100 kHz 1 MHz 10 MHz	1 Um./s										
Triggerart	<p>Auf positiv gehende Überschreitungen des "+" Triggerpegels Auf negativ gehende Überschreitungen des "-" Triggerpegels</p>										
Zählerempfindlichkeit	<p>DC bis 1 MHz; 150 mV_{peak} 10 MHz bis 10 MHz; 300 mV_{peak} Auflösung: 1 mV</p>										
Triggerpegeljustierung	Mittels Daumenrad auf der Frontplatte des PM 2521										

Déjà publié : —
 Concerne : Erratum caractéristiques techniques

Le présent erratum donne les spécifications complètes de:

Mesures de tensions alternatives (section 2.1.2.)
 Mesures de courants alternatifs (section 2.1.4.)
 Mesures de dB (section 2.1.5.) et
 Mesures par compteur (section 2.1.9.)

Conformément à la présente information, les spécifications données dans les sections mentionnées du mode d'emploi 9499 470 15901 ne sont plus valables.

2.1.2. Mesures de tension alternative

Gammes

mV	200
V	2 20 200 2000

Tension maximale d'entrée dans la gamme
 2000 V

600 V

Résolution

10 μ V dans la gamme 200 mV

Une valeur mesurée inférieure à 0,5 % de gamme est affichée
 comme zéro

Nombre d'unités de représentation

21000

Précision (valable entre 3 % et 100 %
 de gamme)

Gamme 200 mV à 200 V inclus	
40 Hz - 500 Hz	\pm (0,3 % d'affichage + 0,15 % de gamme)
a 20 kHz	\pm (1 % d'affichage + 0,15 % de gamme)
a 100 kHz	\pm (5 % d'affichage + 1 % de gamme)

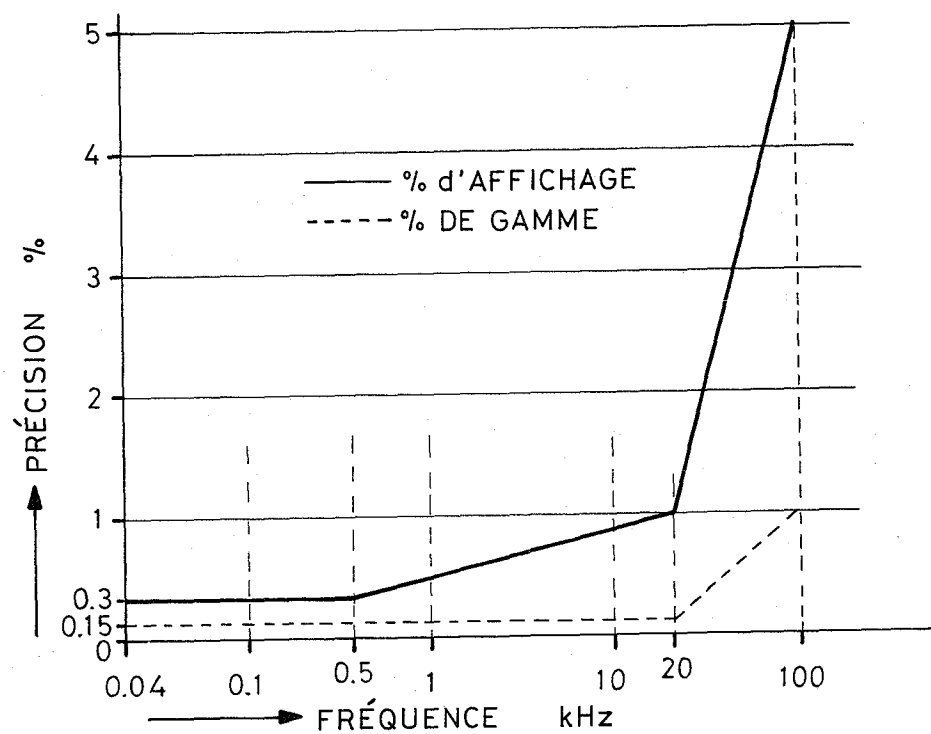

ST 3356

Gamme 2000 V	
40 Hz à 60 Hz	$\pm (0,3 \% \text{ d'affichage} + 0,15 \% \text{ de gamme})$

Coefficient de température

 $\pm (0,03 \% \text{ de l'affichage } / ^\circ\text{C} + 0,01 \% \text{ de gamme } / ^\circ\text{C})$

Impédance d'entrée

Gamme	Impédance d'entrée
200 mV 2 V	20 M Ω //60 pF
20 V	11 M Ω //85 pF
200 V 2000 V	10 M Ω //95 pF

Réjection en mode commun (CMRR)

100 dB pour signaux continus
80 dB pour signaux alternatifs ou 50 ou 60 Hz $\pm 1 \%$

Déecteur alternatif

Convertisseur efficace, couplage capacitif

Facteur de crête

2 en fin de gamme

Temps de réponse

1,5 s sans sélection automatique de gamme
3 s avec sélection automatique de gamme

Tensions maximale d'entrée

Dans toutes les gammes:

entre Hi et Lo 600 V_{eff}entre Hi et terre 1000 V_{eff}entre Lo et terre 400 V_{eff}

Tension maximale continu: 400 V

Produit VHz maxi: 10⁷

2.1.4. Mesures de courant alternatif

Gammes

μA	2 20 200
mA	2 20 200
A	2 20

Courant maximal d'entrée dans la gamme 20 A

10 A

Résolution

1 nA dans la gamme 2 μA

Valeur mesurée inférieure à 0,5 % de la gamme est affichée comme zéro

Nombre d'unités de représentation

2100

Précision

40 Hz - 200 Hz $\pm 0,4 \% \text{ de l'affichage} + 0,15 \% \text{ de la gamme}$

Coefficient de température

 $\pm (0,03 \% \text{ de l'affichage } / ^\circ\text{C} + 0,01 \% \text{ de gamme } / ^\circ\text{C})$

Perte de tension par le shunt

Gamme	Perte de tension	Fréquence
2 μA 20 μA 200 μA 2 mA	< 2,5 mV	50 Hz
20 mA 200 mA	< 25 mV	
2 A 20 A	< 250 mV	

Déecteur alternatif

Convertisseur efficace, couplage capacitif

Facteur de crête

2 en fin de gamme

Temps de réponse

0,7 s sans sélection automatique de gamme
3 s avec sélection automatique de gamme

Protection

Gamme $2 \mu\text{A} - 20 \text{ mA}$; $250 V_{\text{eff}}$
 Gamme $200 \text{ mA} - 20 \text{ A}$; n'est pas protégée
 $I_{\text{max.}} = 20 \text{ A}$ pendant 20 secondes

Tension maxi en mode commun

400 V_{eff} , 560 V crête

Tension maxi d'entrée

dans toutes les gammes:
 entre Hi en Lo 250 V_{eff}
 entre Hi et terre 400 V_{eff}
 entre Lo et terre 400 V_{eff}

2.1.5. Mesures dB (valables en fonction $V_{\sim \text{rms}}$)

Gamme

-57,7 dB à +57,7 dB

0 dB référence

1 mW pour 600Ω 0,775 V ou en sélectionnant la
 référence relative à l'aide du bouton-poussoir ZERO SET
 à l'avant du PM 2521

Résolution

0,1 dB
 Valeur mesurée inférieure à -57,7 dB est affichée comme
 -99,9 dB

Nombre d'unités de représentation

999

Précision

Signaux	Frequence	Précision
-31,7 dB ... +47 dB	40 Hz - 20 kHz 20 kHz - 100 kHz	$\pm 0,2 \text{ dB}$ $\pm 1 \text{ dB}$
-50 dB ... -31,7 dB	40 Hz - 20 kHz	$\pm 2 \text{ dB}$
-57,7 dB ... -50 dB	40 Hz - 20 kHz	$\pm 3 \text{ dB}$
> +47 dB	40 Hz - 500 Hz	$\pm 1,5 \text{ dB}$

Coefficient de température

0,02 dB/°C

Impédance d'entrée

Signaux	Impédance
0 - 1,8 V	20 M Ω //60 pF
1,8 - 18 V	11 M Ω //85 pF
18 - 600 V	10 M Ω //95 pF

Réjection en mode commun (CMRR)

100 dB pour signaux continus
 80 dB pour signaux alternatifs 50 ou 60 Hz $\pm 1 \%$

Déecteur alternatif

Convertisseur efficace, couplage capacitif

Facteur de crête

2 en fin de gamme

Temps de réponse

3 s

Réglage de référence relative

Avec bouton-poussoir ZERO SET à l'avant du PM 2521

Tensions maximales d'entrée

Dans toutes les gammes:
 entre Hi et Lo 600 V_{eff}
 entre Hi et terre 1000 V_{eff}
 entre Lo et terre 400 V_{eff}
 Tension maximale en continu: 400 V
 Produit VHz maxi: 10^7

2.1.9. Mesures de fréquence (Hz)

Gammes

kHz	10	100
MHz	1	10

Sélection de gamme

Gamme 100 kHz, 1 MHz et 10 MHz; manuelle ou
 automatique
 Gamme 10 kHz; manuelle

Résolution

0,1 Hz dans la gamme 10 kHz

Nombre d'unités de représentation

99999

Précision pour les mesures de fréquence

Gamme	Précision
10 kHz 100 kHz 1 MHz	$\pm (0,005 \% \text{ d'affichage} + 0,001 \% \text{ de gamme})$
10 MHz	$\pm (0,01 \% \text{ d'affichage} + 0,001 \% \text{ de gamme})$

Temps de porte

Gamme	Temps de porte
10 kHz	10 s
100 kHz	1 s
1 MHz	100 ms
10 MHz	10 ms

Taux de conversion

Gamme	Taux
10 kHz	1 conv./10 s
100 kHz 1 MHz 10 MHz	1 conv./s

Mode de déclenchement

Par dépassement positif du niveau de déclenchement +
Par dépassement négatif du niveau de déclenchement -

Sensibilité de compteur

continu à 1 MHz; 150 mV_{crête}
10 MHz à 100 MHz; 300 mV_{crête}
Résolution: 1 mV

Réglage du niveau de déclenchement

Avec bouton moleté à l'avant



PHILIPS

SERVICE	Scientific & Analytical Equipment
	Test & Measuring Instruments
	Industrial Automation
	Advanced Automation Systems
	Welding

**Scientific &
Industrial
Equipment
Division**

820607

PM2521

SME95

Already issued : SME93, SME94
 Re : Modifications to the PM2521

From serial number DM 01 3010 on, the PM2521 complies with the VDE safety specifications.
 This modifies the safety input sockets, safety mains cord, etc.
 The service manual of the PM2521 (9499 475 01911), SME93, SME94 and this information sheet should be used.

1. Modification to the part list

Chapter	Part	Old code number	New code number
5.2.	Carrying handle	5322 498 50126	5322 532 14709 ^{498 45 105} 498 54 105
5.3.	Front	5322 447 74009	5322 447 70000 ⁵³
5.3.	TL Potentiometer knob	5322 414 34269	5322 414 30035
5.5.1.	Input sockets	5322 532 14709	5322 267 30435
5.5.1.	Switch for high current ranges	5322 492 62405	deleted
5.5.2.	10A shunt	5322 115 84046	5322 115 80115
<i>Netzbuchse ohne Erdstift</i>			5322 267 30 434

Additions to the part list.

Test prod. black	5322 264 20045
Test prod. red	5322 264 20064
Lead black	5322 321 20572
Lead red	5322 321 20573

2. Modifications to circuit diagrams

The following diagram must be used to adapt the transformer (refer to fig. 58. of the service manual).

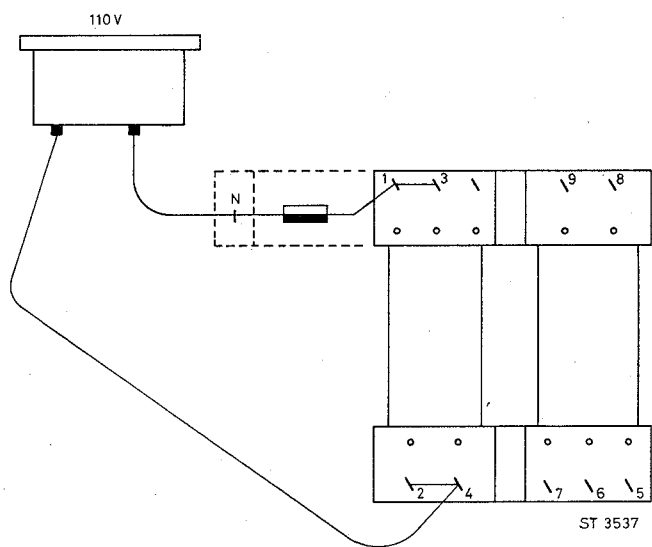
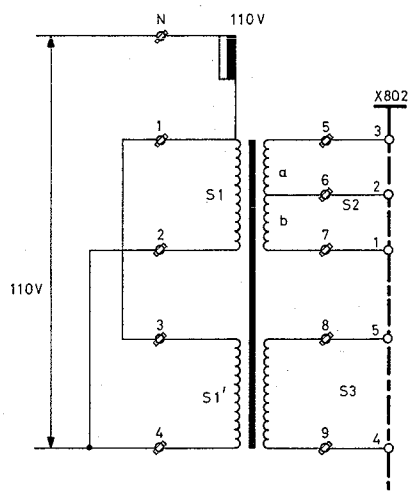
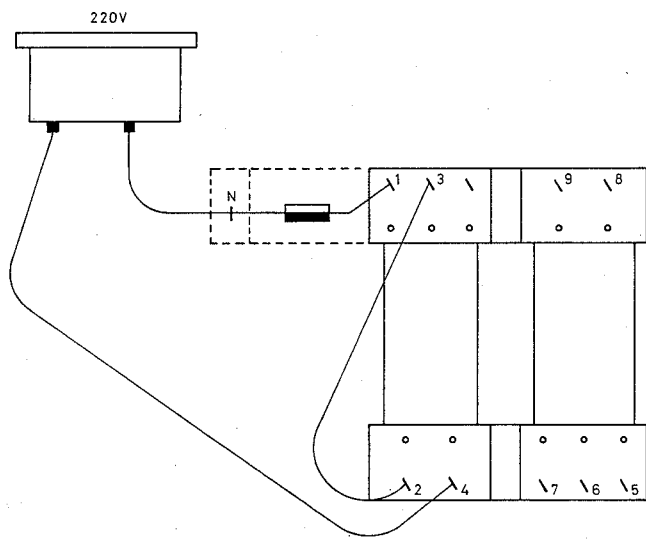
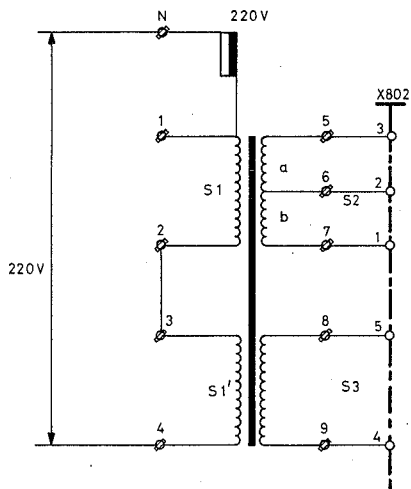
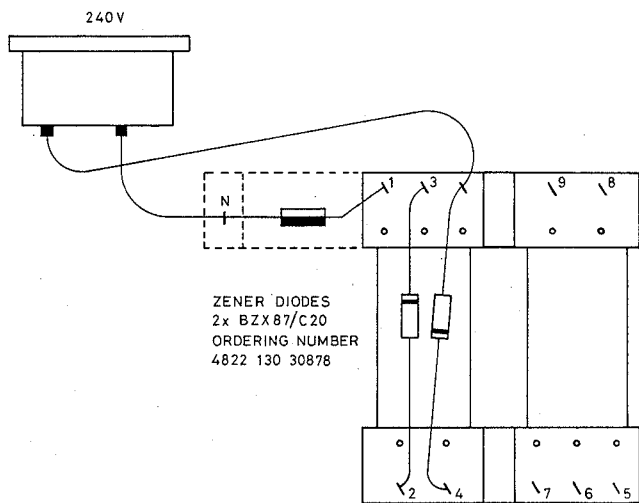
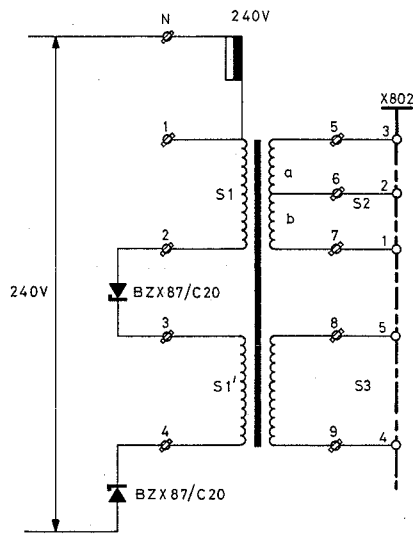

Fig. 58. Adapting the mains transformer



PHILIPS

SERVICE	Scientific & Analytical Equipment
	Test & Measuring Instruments
	Industrial Automation
	Advanced Automation Systems
	Welding

Scientific & Industrial Equipment Division

820214

PM 2521

SME101

Already issued :SME 93, SME 94, SME 95.
 Re :1. Erratum of SME 95
 2. Replacement of ROM's (2x2k--->1x4k)

As documentation for the PM 2521 the service manual 9499 475 01911, SME 93, SME 94, SME 95 and this information sheet should be used.

1. Erratum of SME 95

The following code numbers should be added and modified.

Chapter	Part	Old code number	New code number
5.1	Mains connector	5322 267 44135	5322 267 30434
5.2	Carrying handle	5322 498 50126	5322 498 54105
5.3	Front	5322 447 74009	5322 447 70053
	Test prod. red	5322 264 20064	5322 264 20046

2. ROM's (2x2k--->1x4k)

From serial number DY 02 6611 onwards, the PM 2521/02... is supplied with one 4k ROM.

POS.NR.	Description	Ordering code	Replaced by	Description
D1909	ROM (2k)	5322 209 54696	obsolete	
D1920	ROM (2k)	5322 209 54699	5322 209 81665	ROM (4k)

If an instrument, with 2x2k ROM's, has to be modified to an instrument with a 4k ROM, proceed as follows:

- Unsolder the two soldering spots (see fig 1 and fig 2 item 1)
- Repair the track interruption (see fig 1 item 2)
- Place a jumper. Ordering code 5322 263 64007 (see fig 1 item 3)

9499 478 13211

PRINTED IN THE NETHERLANDS

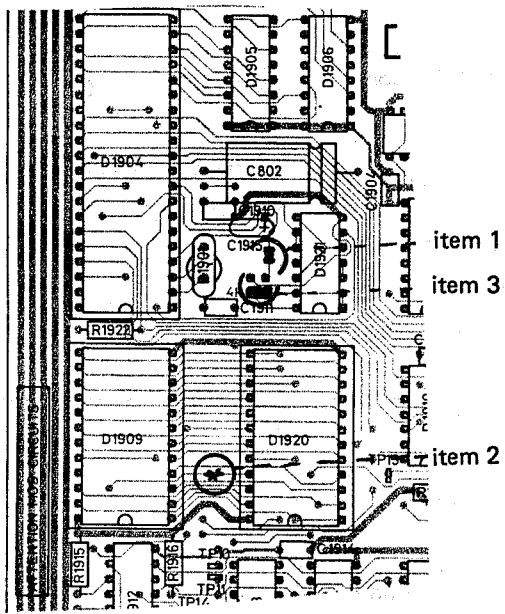

Fig. 1. Main p.c.b. lay-out, component side

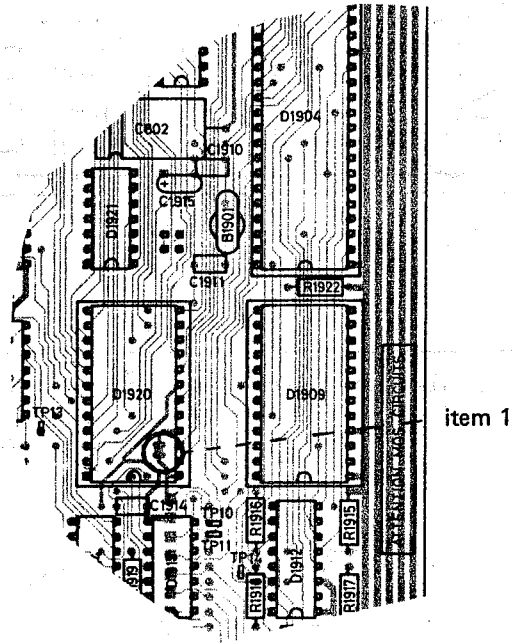

Fig. 2. Main p.c.b. lay-out, conductor side



PHILIPS

SERVICE	Scientific & Analytical Equipment
	Test & Measuring Instruments
	Industrial Automation
	Advanced Automation Systems
	Welding

**Scientific &
Industrial
Equipment
Division**

830916

PM 2521

SME 107

1. Review of the service publications already issued.
2. Review of the existing versions.

1. Review of service publications.
 - standard service manual
 - service informations SME 93, SME 94, SME 107.

Attention: This service information (SME 107) replaces SME 95 and SME 101.

2. Existing versions.
 - 2.1 PM 2521/01 up to serialnumber DY 3010.
This is the standard version, see the service manual.
 - 2.2 PM 2521/02 from serialnumber DY 3010 onwards.
The instruments comply with the VDE safety specifications.

Modifications with respect to version PM 2521/01:

- Service parts list

Part	Code number
Mains connector	5322 267 30434
Front	5322 447 70053
TL Potentiometer knob	5322 414 30035
Input sockets	5322 267 30435
Switch for high current ranges	deleted
10 A shunt	5322 115 80115
Test prod. black	5322 264 20045
Test prod. red	5322 264 20046
Lead black	5322 321 20572
Lead red	5322 321 20573

- Circuit diagrams

The following diagram must be used to adapt the transformer (refer to fig. 58 of the service manual).

9499 478 13811

PRINTED IN THE NETHERLANDS

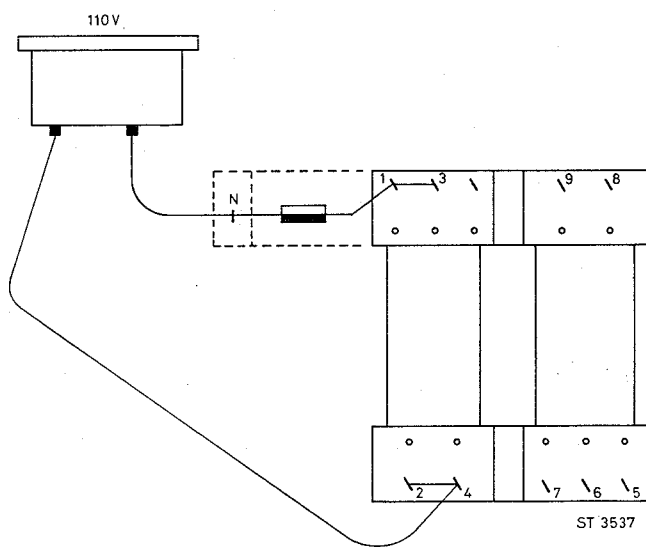
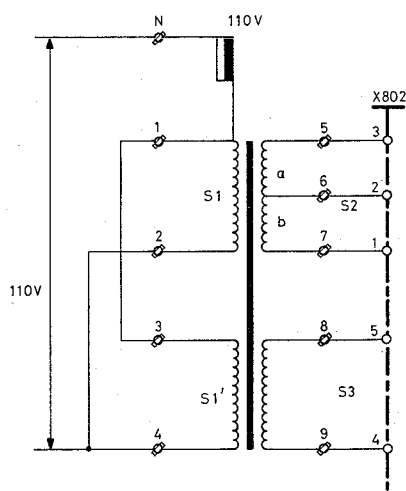
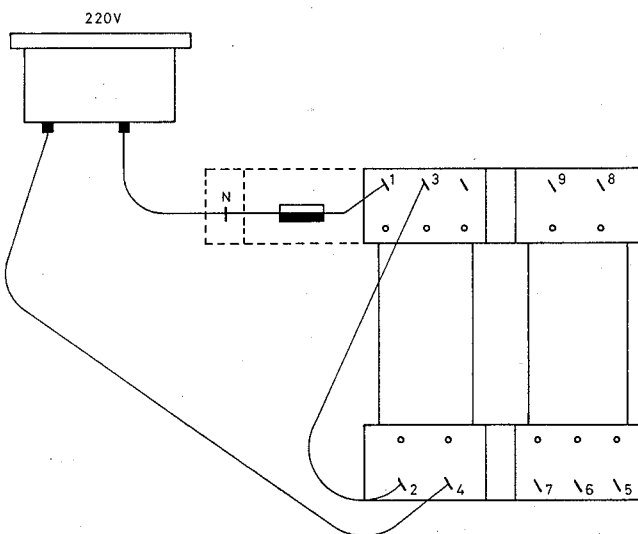
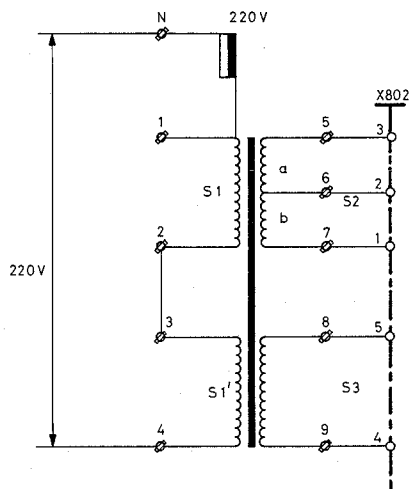
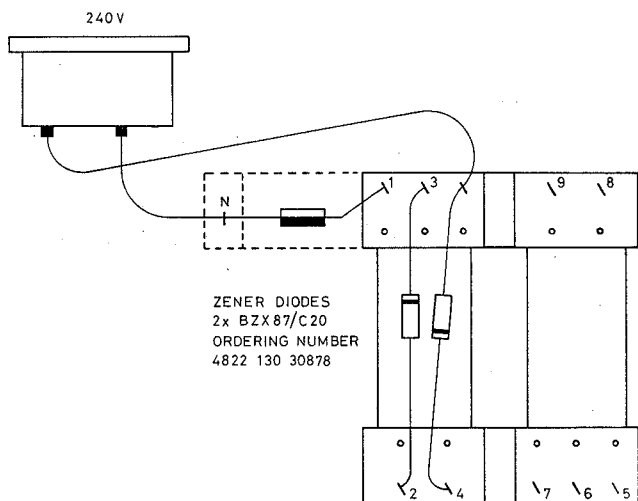
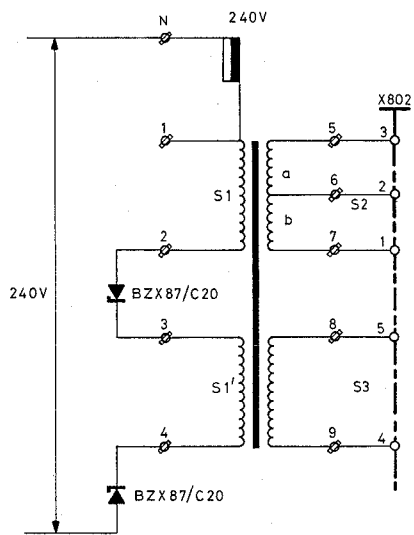

Fig. 58. Adapting the mains transformer

2.3 PM 2521/02 from serialnumber DY 6611 onwards.
 These instruments are provided with a 4K ROM.

Pos.no	Description	Ordering code	Replaced by	Description
D1909	ROM (2K)	5322 209 54696	obsolete	
D1920	ROM (2K)	5322 209 54697	5322 209 81665	ROM (4K)

If an instrument, with 2x2K ROM's, has to be modified to an instrument with a 4K ROM, proceed as follows:

- Unsolder the two soldering spots (see fig. 1 and 2 item 1)
- Repair the track interruption (see fig. 1 item 2)
- Place a jumper. Ordering code 5322 263 64007 (see fig. 1 item 3)

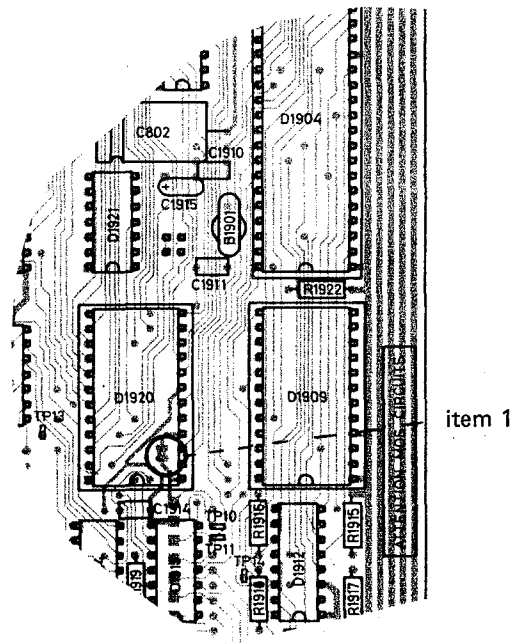
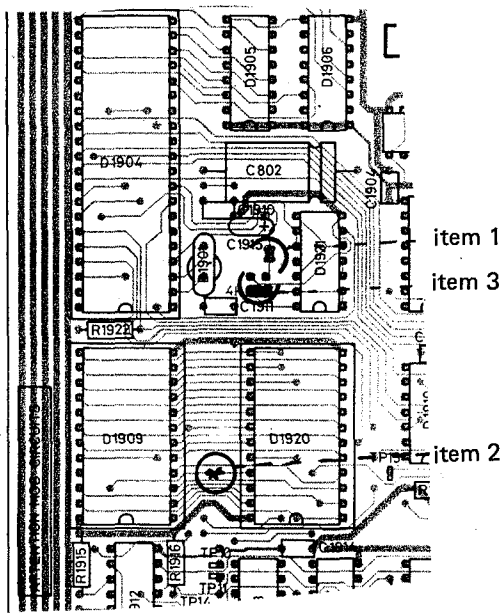

Fig. 1. Main p.c.b. lay-out, component side

Fig. 2. Main p.c.b. lay-out, conductor side

2.4 PM 2521/03 from serial number DY 7611 onwards.
The instruments are delivered in the new colours. (brown)

Modifications with respect to version PM 2521/02

- service parts list

Part	Codenummer
Input sockets	5322 267 30487
Top cover assy.	5322 694 54017
Bottom cover assy.	5322 447 70069
Front	5322 447 70071
Function selector	5322 414 40016
Adjust knob	5322 414 40019
Knob for mains switch	5322 414 20034
Knobs for range selection	5322 414 60037
Handle	5322 498 54105

2.5 PM 2521/22 and PM 2521/23 (battery versions of the PM 2521)

The difference between the PM 2521/22 and the PM 2521/23 is that the PM 2521/22 is delivered in the old colours and the PM 2521/23 in the new colours.

Therefore the service manual for the PM 2521/22 version has to be used for the PM 2521/23 as well.

1. CIRCUIT DESCRIPTION

1.1. GENERAL

The circuit of the Automatic Multimeter PM2521 can be subdivided into three main functional sections as shown in Fig. 1.:

- Analog section
- Control section
- Display section

Each of the sections is described separately in conjunction with the overall circuit diagrams (Fig. 62, 63 and 64).

However, basic circuit diagrams of the various stages are included, within the text, where considered necessary to assist in a better understanding of the more complex parts of the overall circuit. For the principles of operation of the instrument, the reader is referred to the PM2521 Operating Manual.

1.2. SURVEY OF MAIN SECTIONS

The functional circuit blocks within the three main sections, analog, control and display and the basic signal paths are shown in block diagram Fig. 2.

1.2.1. Analog section

The analog section comprises the following input measuring signal facilities:

- a) A voltage measuring path consisting of:
 - A.C./D.C. voltage attenuator
 - R.M.S. convertor (OQ 0061)
 - Active filter
 - ADC (OQ 0064/OQ 0060)
- b) A current measuring path consisting of:
 - A.C./D.C. active I-V convertor
 - R.M.S. convertor
 - Active filter
 - ADC
- c) A resistance/diode measuring path consisting of:
 - Current source (OQ 0063)
 - Active filter
 - ADC
- d) A temperature measuring path consisting of:
 - Thomson bridge
 - Current source
 - ADC
- e) A timer/counter path consisting of:
 - A.C./D.C. voltage attenuator
 - Trigger level circuit

NOTE: The OQ integrated circuits used in this instrument are specially designed LSI circuits for multimeter applications to ensure high accuracy and stability.

Automatic Multimeter PM2521

Instruction Manual

9499 473 00111

820701

Repair by
Signature Analysis

S&I

Scientific & Industrial Equipment Division



PHILIPS

Automatic Multimeter PM2521

Repair by Signature Analysis

Instruction Manual

9499 473 00111

820701

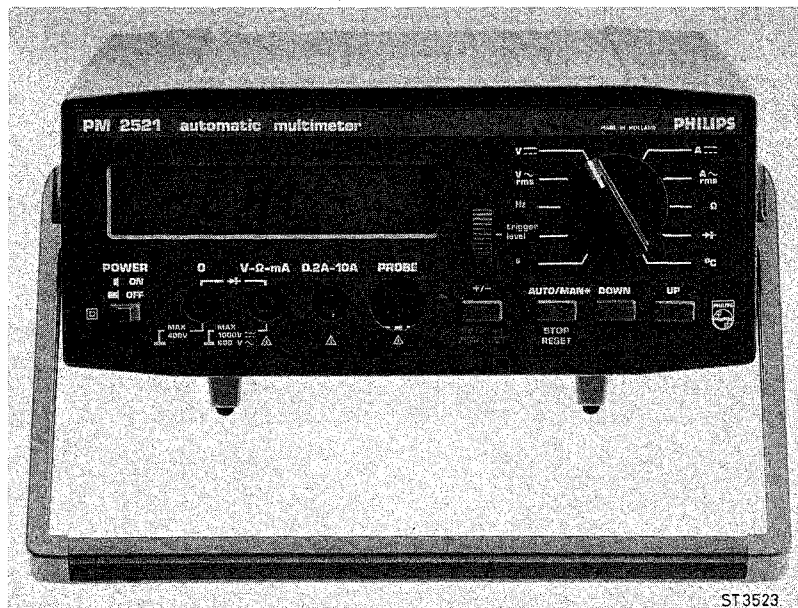

PHILIPS

CONTENTS

Page

1.	General		1
2.	Why use a signature analyser?		1
3.	Check with a signature analyser		1
4.	Type of signature analyser to be used		1
5.	Settings and connection of the signature analyser		2
6.	Brief description of the tests		2
7.	How to use the documentation and the testrom?		3
8.	Fault-finding hints		3
9.	How to order the signature analysis testrom and the documentation?		3
10.	Testing the PM2521		4
10.1.	General		4
10.2.	Free Run test		5
10.3.	Ram and I/O test	test 0	7
10.4.	Visual LCD test	test 1	9
10.5.	Switch decoding test	test 2	10
10.6.	Relay and FET test	test 3	11
10.7.	Static relay and FET test	test 4	12
10.8.	Counter and counter input control test	test 5	14
10.9.	Interrupt controller test	test 6	15

REPAIR BY SIGNATURE ANALYSIS

1. GENERAL

For repair by signature analysis a testrom has been developed. This testrom enables the user to test the digital part of the PM2521 by means of signature analysis. It also enables troubleshooting at component level in the circuit under test, by comparing the actual signature to the correct one. So the trouble-shooter can trace back the faulty node. In total there are 8 tests. In the testrom 7 tests have been implemented and one test is made with the help of the free run facility of the PM2521.

2. WHY USE A SIGNATURE ANALYSER ?

Thanks to the microcomputer in the digital part of the PM2521, the instrument can be very small. Due to this the bus structure is very complex. Data flow on the bus becomes complex and cannot be analysed with an oscilloscope and voltmeter any longer. Therefore the need to test and service the digital part is acute. The trouble-shooting involves the detection of circuit failure and the localization of faults at the source. Finding the fault source in a bus system, such as the bus in the PM2521, with complex feedbacks can be difficult. But opening the feedbacks paths and using the signature analyser makes fault-finding easy.

3. CHECK WITH A SIGNATURE ANALYSER

The signature analyser checks the digital part of the PM2521 by detecting the bit stream at various circuits nodes, and displaying them as hexadecimal signatures.

To do this the PM2521 supplies the signature analyser with three gating signals, or in some cases four: START, STOP, CLOCK and QUALIFIER.

START signals the beginning of a measurement and prepares the signature analyser to receive information from the data probe. STOP closes this measurement. In cases of measuring signatures with RC delays, a QUALIFIER has to be used to stop the incoming information for a short period of time. The CLOCK is the system clock of the PM2521 under test to accept the data synchronously.

NOTE: The active edge of each of these gating signals must be selectable.





4. TYPE OF SIGNATURE ANALYSER TO BE USED ?

The signature analyser to be used in combination with the PM2521 should have the following capabilities:

- Selectable edges of; START, STOP and CLOCK
- A QUALIFIER
- Signatures in the following sequence:

DIGIT	DISPLAY	DIGIT	DISPLAY
0000	0	1000	8
0001	1	1001	9
0010	2	1010	A
0011	3	1011	C
0100	4	1100	F
0101	5	1101	H
0110	6	1110	P
0111	7	1111	U

5. SETTINGS AND CONNECTION OF THE SIGNATURE ANALYSER.

SETTING SIGNATURE ANALYSER		CONNECTION SIGNATURE ANALYSER		
NAME	EDGE	NAME	TESTPOINT	SIGNAL NAME
START	 (neg)	START	TP 14	P17 (D1904 pin 34)
STOP	 (pos)	STOP	TP 14	P17 (D1904 pin 34)
CLOCK	 (pos)	CLOCK	TP 15	\overline{ALE} (D1911 pin 11)
GROUND	---	GROUND	TP 1	Logic 0
QUALIFIER	 (neg)	QUALIFIER	D1903 pin 7	AZC/P
	 (pos)		D1903 pin 2	\overline{AZ}

NOTE: 1. The qualifier is only necessary for test 3 and 5.
2. The testrom must be placed in the D1909 socket.

6. BRIEF DESCRIPTION OF THE TESTS

Free run test

With this test it is possible to measure signatures on the address latches and the databus of the processor. This is necessary to check if the data can be taken from the testrom.

Test 0 (ram and I/O test)

This test checks the internal RAM of the microcomputer. When the RAM is good it will also test the I/O ports of the microcomputer. Only then can signatures be measured on the I/O ports, databus and ROMs. It also activates the connections of the L.C.D. unit.

Test 1 (visual L.C.D. test, no S.A.)

The test fills the display, segment after segment. When a connection to a segment is broken, that segment will not light. When two connections are short circuit, then two segments will be lit simultaneously. In this test signature analysis is not provided.

Test 2 (switch decoding test)

Test 2 activates the circuit necessary for reading the function switch, and the +/–, AUTO, DOWN, UP, 10 Amp. input bus, and the battery low input. Signatures can be measured on IC's D1912, D1916, D1919 and on I/O port 2. (P20, P21, P22, P23 and P25). The signatures on P25 depends on the position of the function switch and keys, pressed or not pressed.

Test 3 (relay/fet switch test)

This test activates the circuit for relay/fet switch control. Signatures can be measured on the inputs of D1908, and the outputs driving the relays. The outputs of D1908 are activated sequentially. Outputs driving the fet's will give stable signatures, but with an oscilloscope it is also possible to see if the fet's are switching.

Test 4 (static relay/fet switch test, no S.A.)

This test is not intended for signature analysis. It sets the relay/fet's in the state, according to the selected function and range. It can also change the internal program status. With the button +/–, the polarity can be changed if the V_{-} , A_{-} , or the function trigger level is selected. With the button AUTO/MAN*, the internal program status can be changed. (normal measurements, AUTOCAL 0,1V or 1V, IZERO 200mA or 2A). So it is possible to make measurements in the analog part of the PM2521.

Test 5 (counter test)

Test 5 activates the counter and counter input control circuit, and the AZC flip-flop D1903. Signature analysis is possible.

Test 6 (interrupt controller test)

Test 6 activates the interrupt control circuit. Signature analysis in this test is also possible.

NOTE: All the signatures are given in circuit diagrams.

*The signatures signed with a * seem to be logic 0 or logic 1 signatures, but the difference is that they have activity at that point. (blinking lamp)
(e.g. only logic 0 or logic 1 between start and stop).*

7. HOW TO USE THE DOCUMENTATION AND THE TESTROM

This service manual should be used in combination with the service manual of the PM2521. The user of the fault-finding procedure in the PM2521 service manual will be directed to a certain part of the PM2521. If the fault-finding procedure does not solve the problem, then select a signature analysis test which is associated with the part of the PM2521.

Begin always with the microcomputer, or with the inputs of the integrated circuits, and try to find the faulty node. Bear in mind that when the faulty node has been found, more than one circuit can cause the faulty signature.

8. FAULT-FINDING HINTS

The first thing to do is to get an analysis of what is wrong. If this is not possible (e.g. continuously —cal—), get the PM2521 in the free run mode by breaking the bus system between the microcomputer and the ROMs. This is done by removing the ROMs.

The microcomputer is now forcing—in some instruction that will cause a repeated increment of the address lines. So at this point the microcomputer is scanning the whole address field.

With START and STOP lines from the signature analyser, both connected to the most significant address bit and triggering on different edges, a measurement will be defined. Connecting the CLOCK line of the signature analyser to the ALE signal of the microcomputer and selecting the edge at which the address is valid, the input probe will get a signature at every address line.

By touching the probe in every test to a logic 1 level, a characteristic signature is obtained. This is the result of shifting ones (logic 1) in for every cycle that occurs while the gate is open. So the characteristic signature can be used to diagnose this condition elsewhere. The logic 0 is always a signature of "0000". Assume there are no bad signatures in the free-run test, then the TESTROM can be placed in the D1909 socket and it is possible to start measuring with test 0.

If an incorrect part can be located with the fault-finding procedure it is recommended to start with the test which is responsible for that fixed part of the PM2521.

To do this, short circuit TP10 and TP11 for a short period.

9. HOW TO ORDER THE SIGNATURE ANALYSIS TESTROM AND THE DOCUMENTATION

Under ordering number 5322 694 54013 the testrom and the documentation can be ordered from Concern Service.

10. TESTING THE PM2521

10.1. General

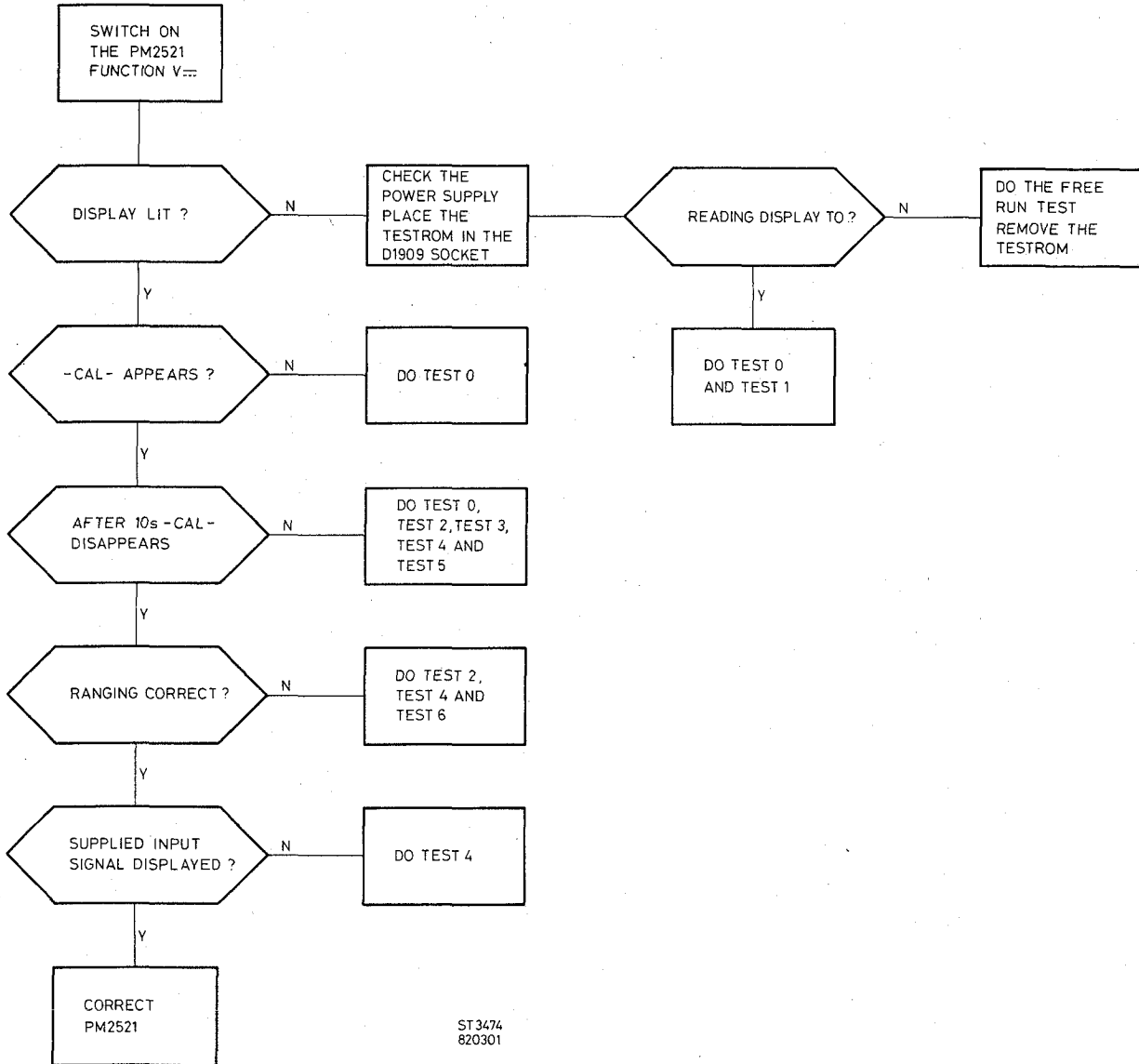

ST 3474
820301

10.2. Free-run test.

Settings signature analyser

Setting	Edge	Testpoint	Signalname
start	⌋ (neg)	D1905 pin 12	A10
stop	⌋ (pos)	D1905 pin 12	A10
clock	⌋ (pos)	TP15	ALE
ground	—	TP1	logic 0

NOTE: 1. Remove D1909 and D1920 (ROMs).
 2. Signals with a * seem to be logic 0 or logic 1 but still show activity. (blinking led.)
 3. Reference logic 0 = 0000
 logic 1 = 8P54

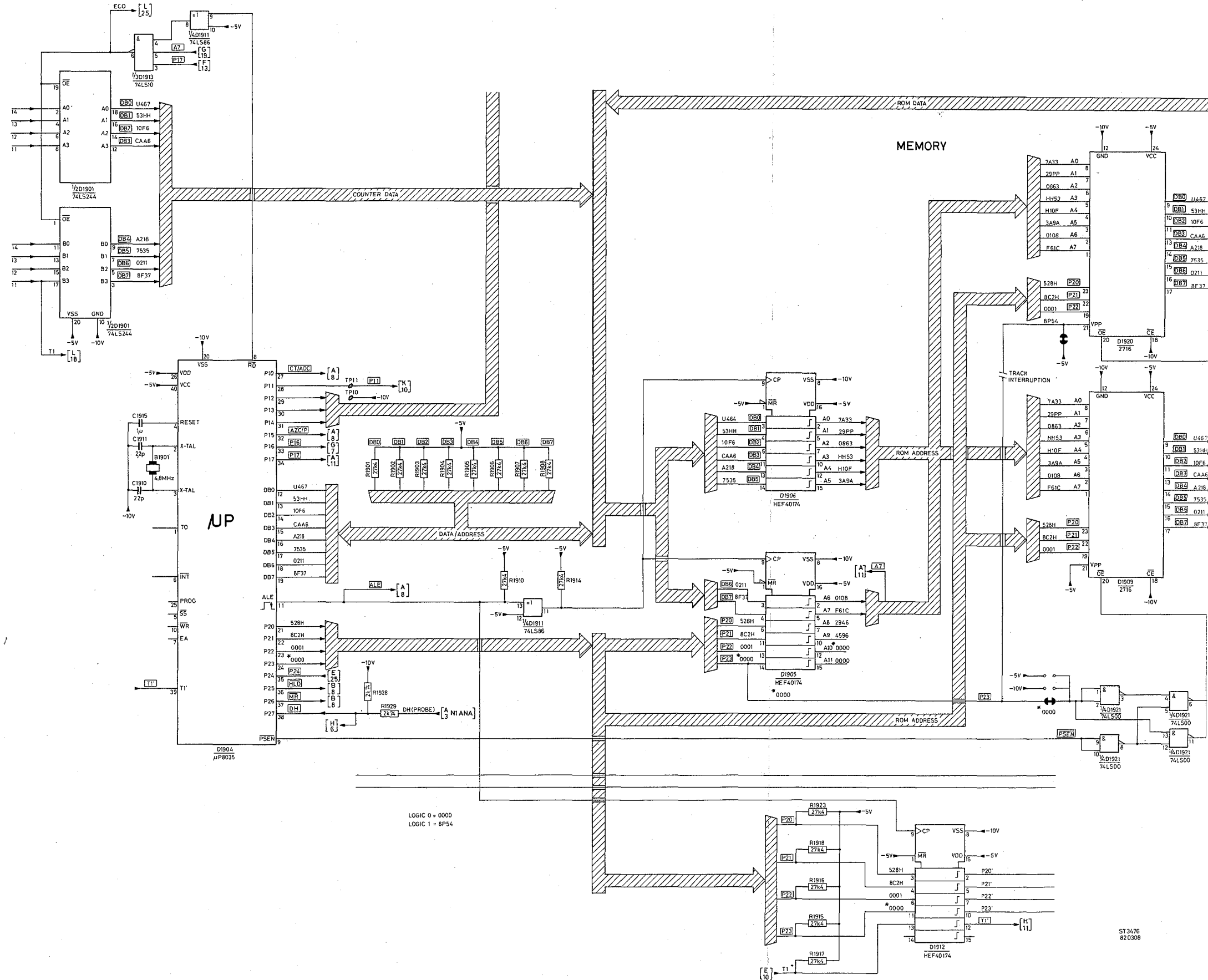
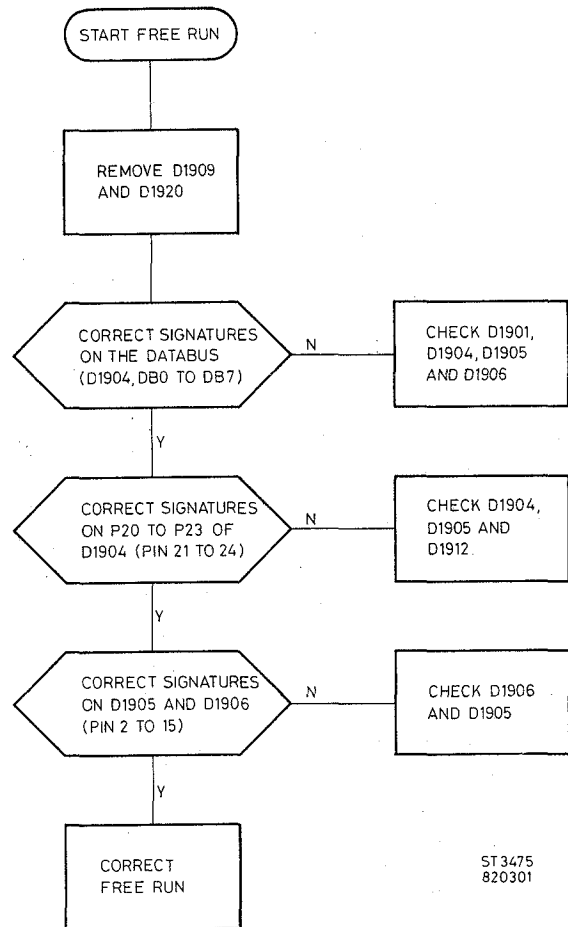

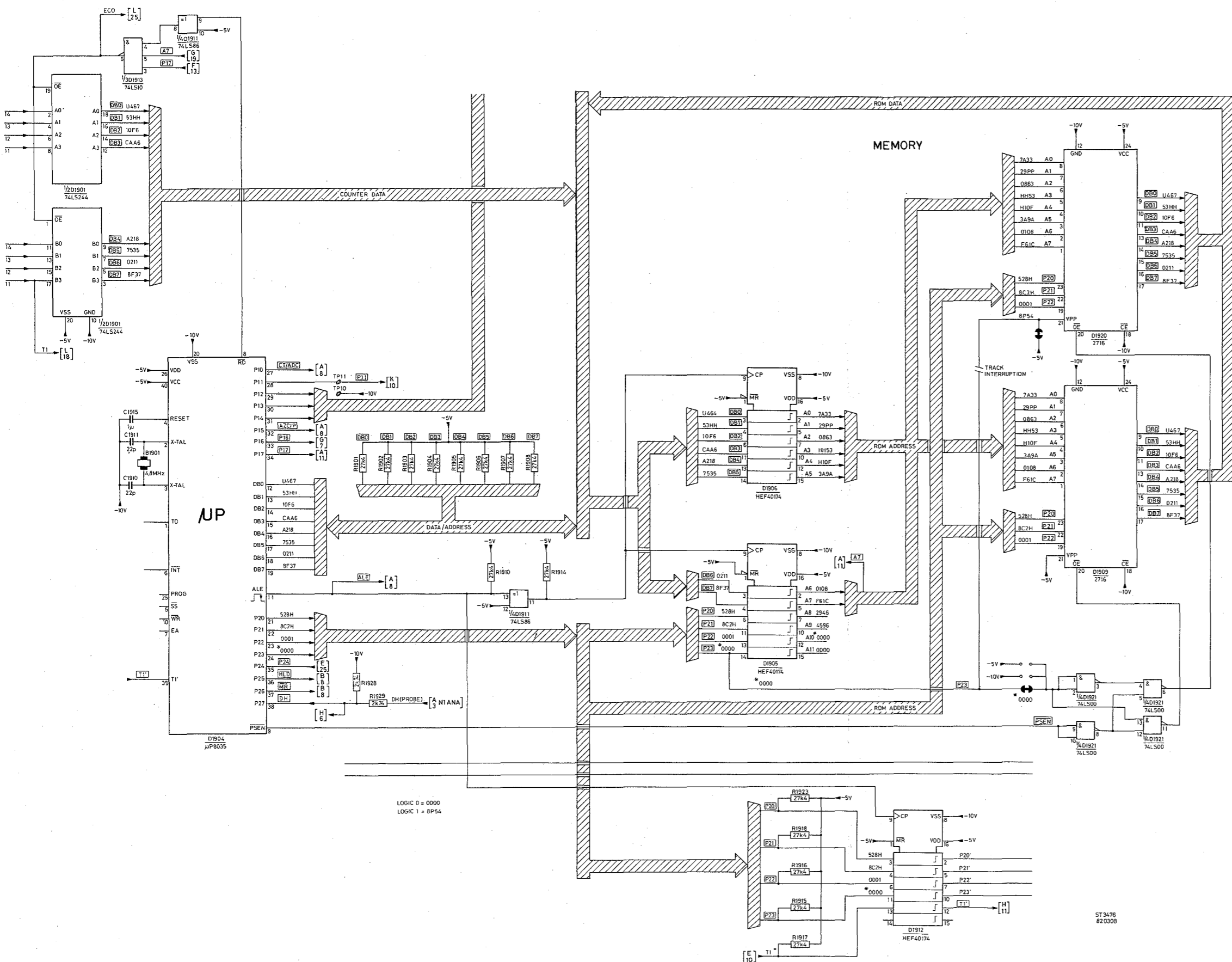

573476
420308

10.3. Test O (RAM and I/O test)

Settings signature analyser

Setting	Edge	Testpoint	Signalname
start	⌊ (neg)	TP14	P17 (D1904 pin 34)
stop	⌋ (pos)	TP14	P17 (D1904 pin 34)
clock	⌋ (pos)	TP15	ALE (D1911 pin 11)
ground	—	TP1	Logic 0

- NOTE: 1. The testrom placed in the D1909 socket.
 2. Reference logic 0 = 0000.
 logic 1 = HCH5
 3. Reading display: $\underline{\text{E}} \square$

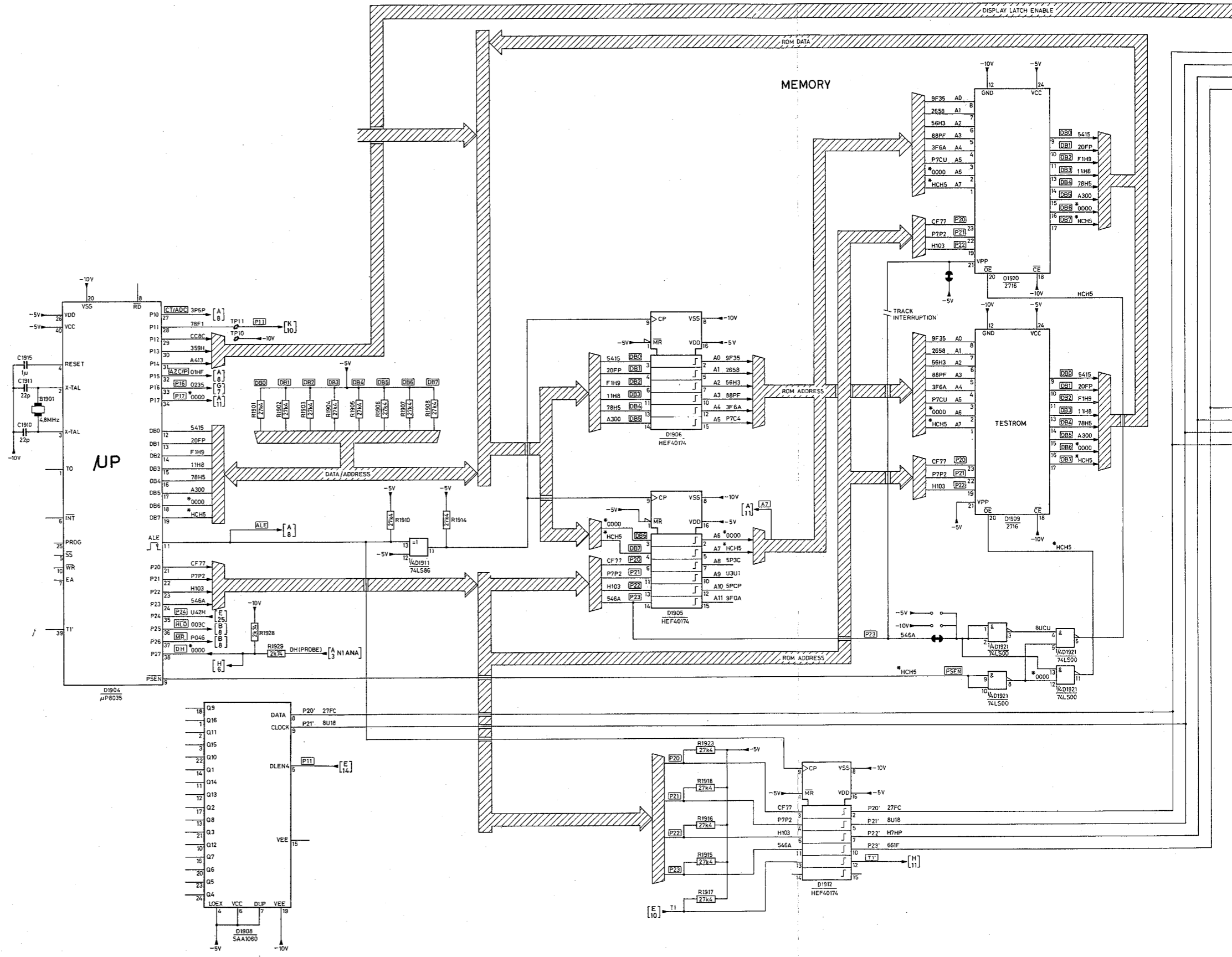

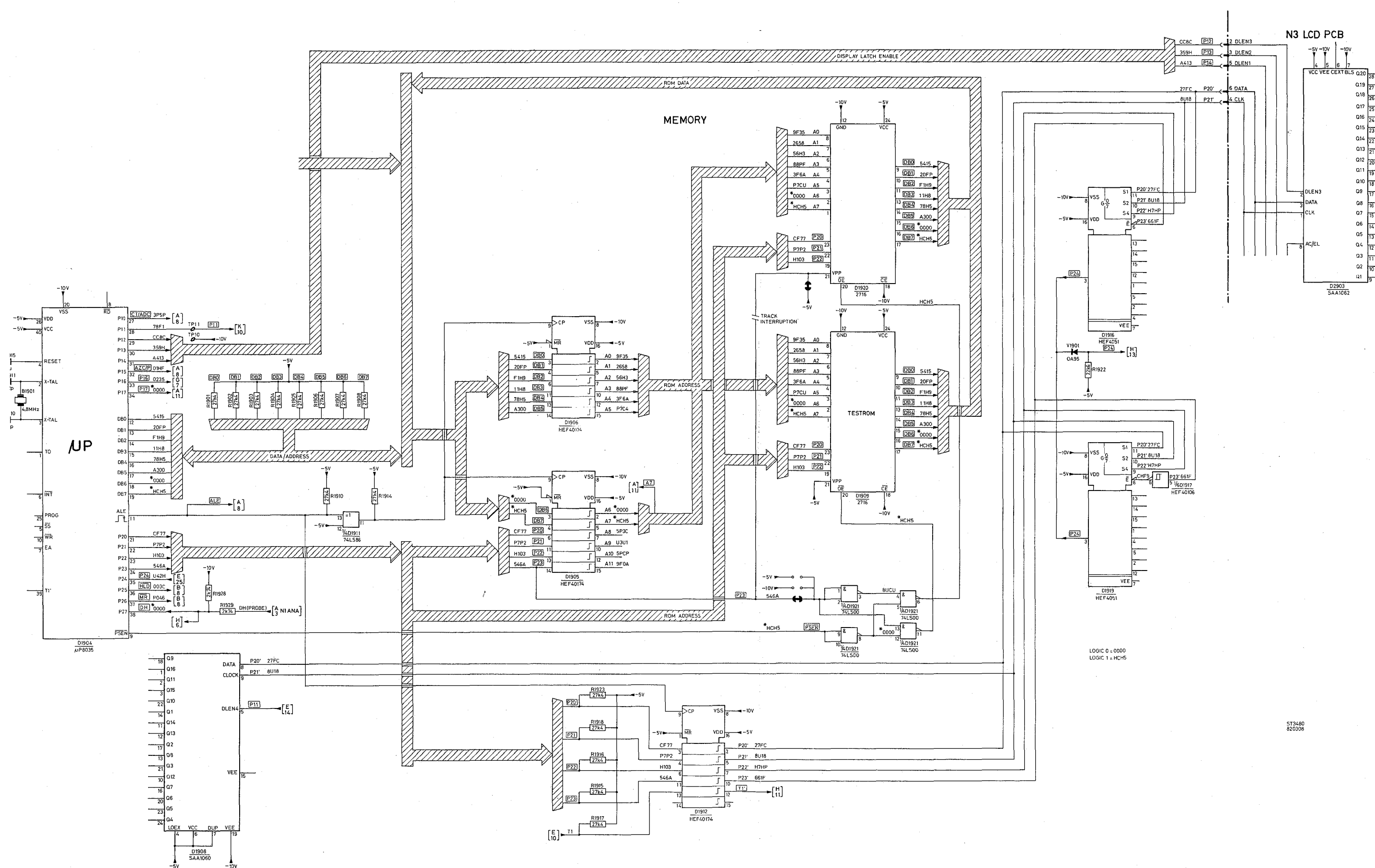

N3 LCD PCB

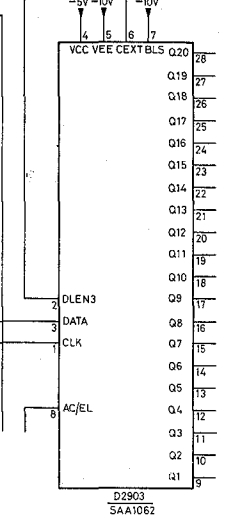

LOGIC 0 = 0000
LOGIC 1 = HCH5

10.4. Test 1 (visual L.C.D. test, no S.A.)

This test is a visual L.C.D. test which fills the display, segment after segment. If all segments are lit the display becomes empty and the whole measuring sequence starts again.

Only when all segments are lit can the test be stopped by short circuiting TP10 and TP11.

When a connections are short circuited then the segments will light simultaneously.

- NOTE: 1. Testrom placed in D1909 socket (Both ROMs removed)
 2. Short circuit TP10 and TP11
 3. Reading on display: All segments will be filled.

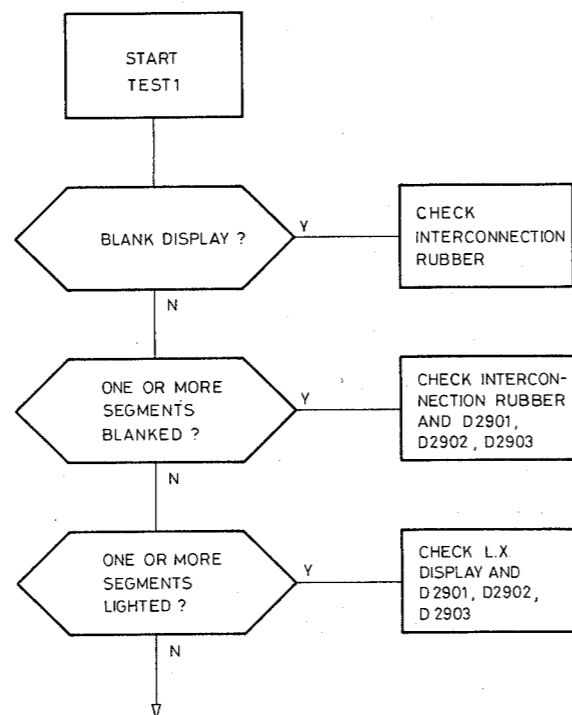

ST3473
820301

CONNECTION TABLE

CONNECTIONS D2901 D2902 D2903		D2901	LX-display	D2902	LX-display	D2903	LX-display
Output no.	Pin no.	Char.	Pin no.	Char.	Pin no.	Char.	Pin no.
Q1	9		2	.3	22	a5	42
Q2	10	-	3	d3	23	b5	43
Q3	11	+	4	e3	24	g5	44
Q4	12	GATE	5	f3	25	c5	45
Q5	13	.1	6	a3	26	M (Hz)	46
Q6	14	d1	7	b3	27	k (Hz)	47
Q7	15	e1	8	g3	28	Hz	48
Q8	16	f1	9	c3	29	Z	49
Q9	17	a1	10	.4	30	s	50
Q10	18	b1	11	d4	31	V	51
Q11	19	g1	12	e4	32	A	52
Q12	20	c1	13	f4	33	*	53
Q13	21	.2	14	a4	34	m	54
Q14	22	d2	15	b4	35	μ	55
Q15	23	e2	16	g4	36	°C	56
Q16	24	f2	17	c4	37	Ω	57
Q17	25	a2	18	.5	38	k (Ω)	58
Q18	26	b2	19	dB	39	M (Ω)	59
Q19	27	g2	20	e5	40	n.c.	-
Q20	28	c2	21	f5	41	n.c.	-

10.5. Test 2 Switch decoding test

Due to the capacitors in the circuit which read-out the function switch, the signatures on point 3 of D1916 and D1919 (P24) are unstable. Therefore the microcomputer reads the signatures on P24 and sends them to P25. This gives a stable signature which can be measured by the signature analyser.

Settings signature analyser

Setting	Edge	Testpoint	Signalname
start	⌋ (neg)	TP14	P17 (D1904 pin 34)
stop	⌋ (pos)	TP14	P17 (D1904 pin 34)
clock	⌋ (pos)	TP15	ALE (D1911 pin 11)
ground	—	TP1	Logic 0

- NOTE: 1. The testrom placed in the D1909 socket. (Both ROMs removed).
 2. Short circuit TP10 and TP11.
 3. Reading on display **EE**
 4. Reference logic 0 = 0000
 logic 1 = C66C

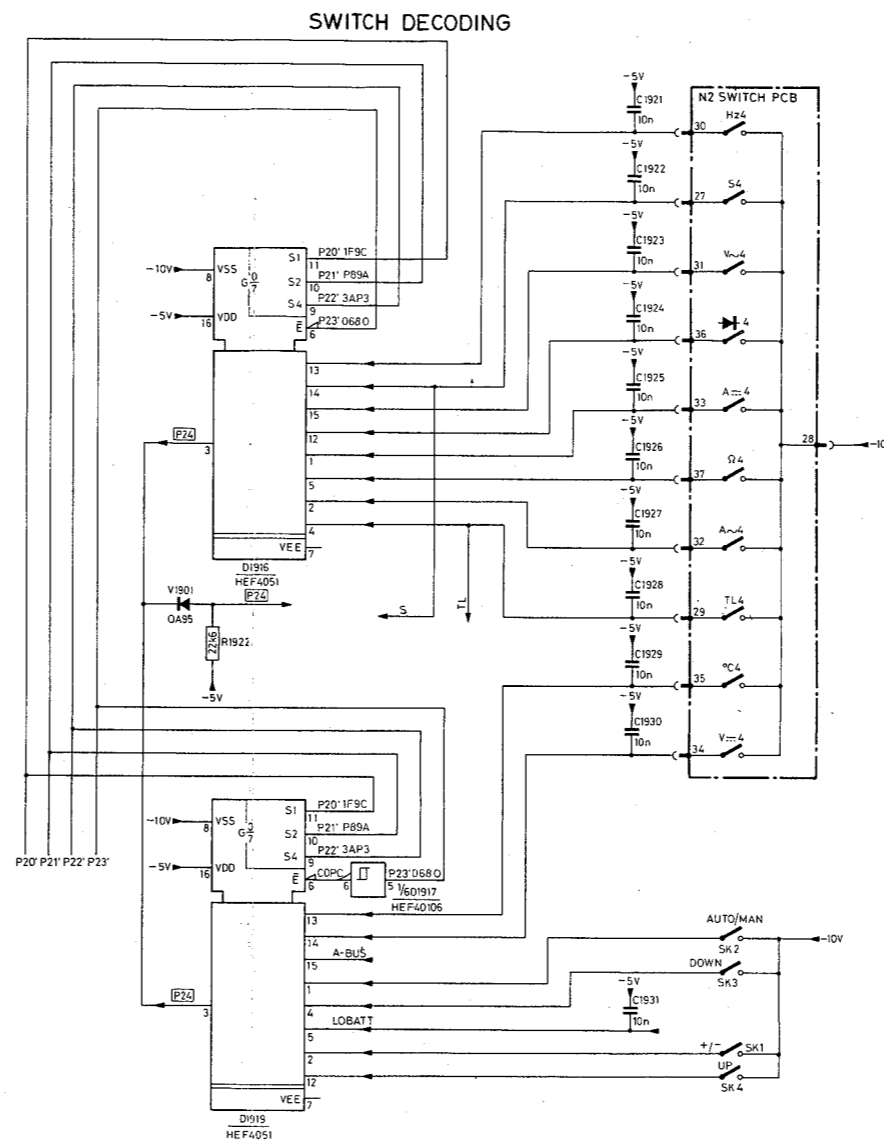
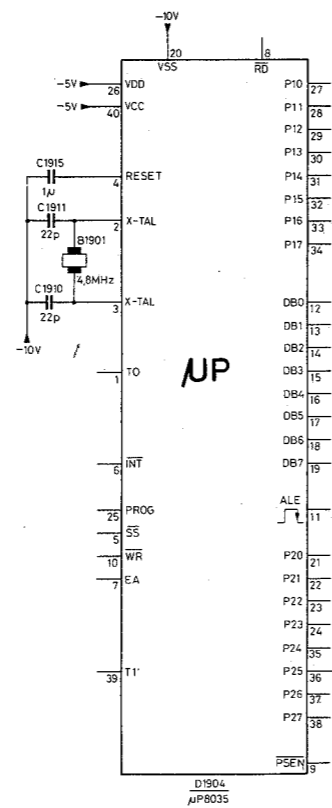

POSITION	SIGNATURE
V _{CC}	3A08
V _{SS}	7F0F
Hz	45AU
TRIGGER LEVEL	8076
S	968A
C	251C
Ω	139P
A _~	A514
A _~	5AU2
A _~	677C
V _{CC} AND ↑	HU11
V _{CC} AND AUTO/MAN	538F
V _{CC} AND DOWN	3AF7
V _{CC} AND UP	1C2P
V _{CC} AND A BUS (LEAD IN A BUS)	7520

LOGIC 0 = 0000
 LOGIC 1 = C66C

ST 3479
 820309

10.6. Test 3 (Relay and FET test).

Setting	Edge	Testpoint	Signalname
start	⌋ (neg)	TP14	P17
stop	⌋ (pos)	TP14	P17
clock	⌋ (pos)	TP15	ALE
qualifier	⌋ (neg)	D1903 pin 7	AZC/P
qualifier	⌋ (pos)	D1903 pin 2	AZ
ground	—	TP1	Logic 0

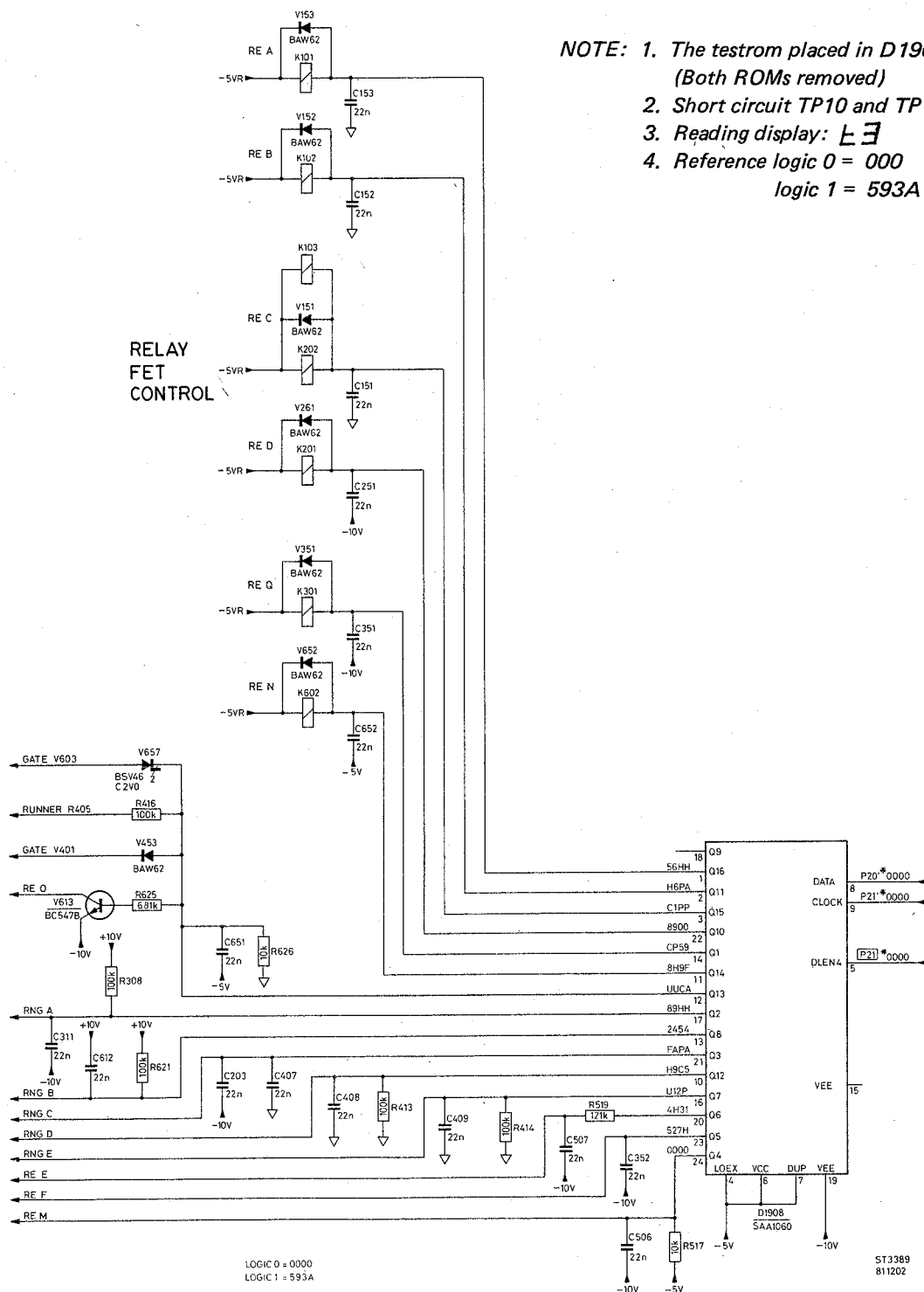

10.7. Test 4 (Static relay and FET test, no. S.A.)

This test sets all the RELAYS/FETS corresponding to the selected function and range. With the +/- button the AZ status can be changed, and also in the functions V_{\sim} , A_{\sim} , and trigger level, the polarity can be changed. Pushing the AUTO/MAN* button starts another measurement.

POSSIBLE READINGS BY PRESSING THE UP, DOWN AND +/- BUTTONS.

Position	Readings	Position	Readings
V=	+/- PO-t4 mV	A=	+/- P.O-t4 uA
	+/- P.O-t4 V		+/- PO.-t4 uA
V~	+/- PO.-t4 V	A~	+/- PO.-t4 uA
	+/- PO-t4 V		+/- P.O-t4 mA
Hz	+/- PO-t.4 V	°C	+/- PO.-t4 mA
	~ PO-t.4 V		With lead in the A-bus
Trigger level	~ P.O-t4 V	Diode	+/- PO.-t4 mA
	~ PO.-t4 V		+/- P.O-t4 mA
s	~ PO-t.4 V	Ω	+/- PO.-t4 mA
	~ PO-t.4 V		~ PO.-t4 mA
s	P.O-t4 KHz	Ω	~ P.O-t4 mA
	PO.-t4 KHz		~ PO.-t4 mA
s	.PO-t4 MHz	Ω	With lead in the A-bus
	P.O-t4 MHz		~ PO.-t4 mA
s	gate +/- P.O-t4 V	Ω	~ P.O-t4 mA
	gate +/- PO.-t4 V		~ PO.-t4 mA
s	gate +/- PO.-t4 V	Ω	~ P.O-t4 mA
	gate +/- PO-t.4 V		~ PO.-t4 mA
s	P.O-t4 s	Ω	PO.-t4 Ω
	PO.-t4 s		P.O-t4 KΩ
s	PO-t.4 s	Ω	PO.-t4 KΩ
	PO-t.4 s		P.O-t4 KΩ
s	PO-t4 s	Ω	P.O-t4 MΩ
	PO-t4 s		PO.-t4 MΩ

NOTE: In these ranges the relays are also set.

By pressing the auto/man* button the measurement number can be changed.

NUMBER OF PRESSINGS	RELAYS SETTING	DISPLAY
0	normal measurement	...PO....
1	AUTO CAL 0.1V	...P1....
2	normal measurement	...P2....
3	IZERO 200mA	...P3....
4	normal measurement	...P4....
5	AUTO CAL 1V	...P5....
6	normal measurement	...P6....
7	IZERO 2A	...P7....

DESCRIPTION

When making a normal measurement (..PO...) the microcomputer sets all the relays and FET's which are necessary to make a measurement. For instance: Select the V_{m} function and the range 200mV. The relays and FET's which are now set can be found in the relay table. So it is possible to determine if the relays are really set.

When making an AUTOCAL 0,1V (..P1...) the microcomputer programs the OQ 0063 so that a current of 100 μA flows through R606, which causes a voltage drop of 100mV across it. With this test it is possible to measure this voltage.

In the position AUTOCAL 1V (..P5...) the microcomputer programs the OQ 0063 to give a current of 1mA through R606. The result is 1V across R606.

With the I ZERO measurements, normally the offset is measured in the I-V convertor. (current offset). In the ..P3... and the ..P7... tests these IZERO measurements are simulated. (see relay table on page 52 and page 53 of the PM2521 service manual).

In all these tests (..PO... to ..P7...) the AZ status can be changed. This means that the input of the ADC can be selected. To do this push the +/- button. Thanks to this it is possible to measure the input voltage, or the voltage across the R606 resistance, on the input of the ADC (pin 5 and pin 10 of the OQ 0064)

Example:

When there is no input signal, the voltage on pin 5 and pin 10 of the ADC is 0,460V. (with respect tot the 0 input socket)

Set 200mV on the input terminals. After attenuation the voltage on point 6 of A601 is 100mV.

This voltage of 100mV causes either a voltage of 0,360V on pin 5 of A602 or a voltage of 0,360V on pin 10 of A602, depending on the state of the AZ flip-flop. ($0,460\text{V} - 0,1\text{V} = 0,360\text{V}$).

So the input voltage after attenuation degrades the voltage on pin 5 or pin 10 corresponding to the input signal.

10.8. Test 5 (Counter and counter input control test).

Settings signature analyser

Setting	Edge	Testpoint	Signalname
start	⌋ (neg)	TP14	P17
stop	⌋ (pos)	TP14	P17
clock	⌋ (pos)	TP15	ALE
ground	—	TP1	logic 0

- NOTE: 1. Testrom placed in D1909 socket (Both ROMs removed)
 2. Short circuit TP10 and TP11
 3. Reading on display: **ES**
 4. Connect point 1 of D1910 to logic 0
 5. Adjust with R502 the signature on D1911 point 2 to 0000
 6. Select the signature on point 15 of D1903 with the +/- button: 154H
 7. Reference logic 0 = 0000
 logic 1 = 3UH7

