

System Multimeter PM2534 - PM2535

Service Manual

4822 872 35313
900205



ST5665



ST4845



PHILIPS

IMPORTANT

In correspondence concerning this system, please quote the type number and serial number of the units as given on the type plate.

NOTE: The design of this system is subject to continuous development and improvement. Consequently, this system may incorporate minor changes in detail from the information contained in this manual.

THIS SERVICE MANUAL REPLACES:

- the first edition Service Manual 4822 872 35302
- the second edition Service Manual 4822 872 35312
- Service note SME 126, 4822 872 38308
- Service note SME 130, 4822 872 38313
- Service note SME 132, 4822 872 38315

1.	SAFETY INSTRUCTIONS	1-1
2.	CHARACTERISTICS AND PERFORMANCE TEST	2-1
3.	CIRCUIT DESCRIPTION	3-1
3.1	Explanation of the block diagram	3-1
3.2	Detailed description	3-6
3.3	Analog section	3-6
3.3.1	V dc measurement	3-7
3.3.2	V ac measurement	3-9
3.3.3	DC/AC current measurements	3-11
3.3.4	Resistance measurement	3-11
3.3.5	Temperature measurement	3-12
3.3.6	Multiplexer	3-12
3.3.7	Control of analog section	3-12
3.3.8	Guard circuit	3-12
3.3.9	Analog to Digital conversion	3-13
3.3.9.1	General	3-13
3.3.9.2	ADC principle	3-13
3.3.9.3	Automatic zero	3-14
3.3.9.4	DAC	3-14
3.3.10	Reference voltages	3-14
3.3.11	Inguard-outguard connection	3-15
3.4	Digital section	3-15
3.4.1	Software description	3-15
3.4.2	RAM/ROM	3-16
3.4.3	I ² C bus	3-16
3.5	IEEE/IEC interface	3-17
3.5.1	Receiving	3-17
3.5.2	Transmitting	3-17
3.6	Display/keyboard	3-18
3.7	Data of components	3-18
3.7.1	8031 AH microcomputer	3-18
3.7.2	MAF 8441	3-22
3.7.3	DAC 08 E	3-24
3.7.4	TL 7705A	3-25
3.7.5	OM 503	3-26
3.7.6	SA 1045	3-27
3.7.7	OQ 0300	3-28
3.7.8	OQ 0301	3-29
3.7.9	SA 1300	3-31
3.7.10	PCF 8574	3-31
3.7.11	OQ 0068	3-33
3.7.12	LTC 1052	3-34
4.	DISMANTLING THE INSTRUMENT	4-1
4.1	Removing the cover	4-1
4.2	Removing the top screening	4-2

4.3	Removing the bottom screening	4-2
4.4	Removing the front assembly	4-2
5.	CHECKING AND ADJUSTING	5-1
5.1	General information	5-1
5.2	Calibration adjustments.....	5-1
5.3	Adjusting the PM2534/PM2535 using a controller.....	5-4
6.	CORRECTIVE MAINTENANCE	6-1
6.1	Special parts	6-1
6.2	Replacing parts	6-2
6.2.1	Parts on the PCB	6-2
6.2.2	LX-display, window and interconnection rubber	6-2
6.2.3	Input unit	6-3
6.2.4	Interchanging input unit	6-4
6.2.5	Fuses	6-4
6.3	Trouble shooting	6-5
7.	SAFETY INSPECTION AND TESTS AFTER REPAIR AND MAINTENANCE IN THE PRIMARY CIRCUIT	7-1
7.1	General directives	7-1
7.2	Safety components	7-1
7.3	Checking the protective earth connection	7-1
7.4	Adaption to the local mains	7-2
7.5	Adaption to the local mains frequency	7-2
8.	PARTS LIST	8-1
8.1	Mechanical parts	8-1
8.2	Electrical parts	8-3
9.	CIRCUIT DIAGRAMS AND PRINTED CIRCUIT BOARDS LAY-OUTS	9-1
10.	GLOSSARY OF TERMS	10-1
11.	MODIFICATIONS	
11.1	Hardware modifications	11-1
11.2	Software modifications	11-7

1. SAFETY INSTRUCTIONS

Read this page carefully before installation and use of the instrument.

The following clauses contain information, cautions and warnings which must be followed to ensure safe operation and to retain the instrument in a safe condition.

Adjustment, maintenance and repair of the instrument shall be carried out only by qualified personnel.

1.1 GENERAL CLAUSES

- 1.1.1 **WARNING:** The opening of covers or removal of parts, except those to which access can be gained by hand, is likely to expose live parts and accessible terminals which can be dangerous to life.
- 1.1.2 The instrument shall be disconnected from all voltage sources before it is opened.
- 1.1.3 Bear in mind that capacitors inside the instrument can hold their charge even if the instrument has been separated from all voltage sources.
- 1.1.4 **WARNING:** Any interruption of the protective earth conductor inside or outside the instrument, or disconnection of the protective earth terminal, is likely to make the instrument dangerous. Intentional interruption is prohibited.
- 1.1.5 Components that are important for the safety of the instrument may only be renewed by components obtained through your local Philips organisation.
- 1.1.6 After repair and maintenance in the primary circuit, safety inspection and tests, as mentioned in Section 7 must be performed.

CHARACTERISTICS AND PERFORMANCE TEST

CHARACTERISTICS

For the characteristics of the PM2534 and PM2535 refer to chapter 2 of the operating manuals of these instruments.

The hardware of the PM2534 and the PM2535 is almost identical. Differences are indicated where necessary.

PERFORMANCE TEST FOR THE PM2534 AND PM2535

The meter should be calibrated and in operating condition when the customer receives it.

The following performance tests are provided to ensure that the meter is in a proper operating condition. If the instrument fails any of the performance tests, then calibration adjustment and /or repair is needed. To perform these tests, you will need a :

- * Fluke 5700 A Multifunction calibrator (or equivalent).
- * Philips PM9264/01 four wire OHM cable.

Each of the measurements listed in the following steps assume the instrument is being tested after a one-hour warmup, in an environment with an ambient temperature of 18 to 28°C, and a relative humidity of less than 80 %.

NOTE: All measurements listed in the performance test tables are made in the initial measuring speeds. These speeds are automatically switched on when the functions are selected.

The ranges of the meter must be selected in the manual ranging mode.

PROCEDURE

1. Power-up the meter and allow it to stabilize for one hour.
2. Connect a cable from the output HI and LO connectors of the Fluke 5700 A to the V- Ω -mA and 0 connectors on the PM2534/PM2535.

Select the function and range on the meter and the input level from the calibrator using the values listed in the tables.

The display should read between the minimum and the maximum values listed in the tables.

FUNC.	RANGE	INPUT LEVEL	FREQ.	DISPLAY	
				MINIMUM	MAXIMUM
Vdc	300 mV	short	-	- 000.005	+ 000.005
	300 mV	+ 300.000 mV	-	+ 299.974	+ 300.026
	300 mV	- 300.000 mV	-	- 300.026	- 299.974
	3 V	+ 3.00000 V	-	+ 2.99981	+ 3.00019
	3 V	- 3.00000 V	-	- 3.00019	- 2.99981
	30 V	+ 10.0000 V	-	+ 09.9989	+ 10.0011
	30 V	+ 15.0000 V	-	+ 14.9986	+ 15.0014
	30 V	+ 30.0000 V	-	+ 29.9985	+ 30.0015
	30 V	- 30.0000 V	-	- 30.0015	- 29.9985
	300 V	+ 300.000 V	-	+ 299.978	+ 300.022
300 V	- 300.000 V	-	- 300.022	- 299.978	
Vac	300 mV	short	-	000.00	000.00
	300 mV	300.00 mV	400 Hz *	299.10	300.90
	300 mV	200.00 mV	40 Hz	199.30	200.70
	300 mV	200.00 mV	1 KHz	199.30	200.70
	300 mV	200.00 mV	50 KHz	193.00	207.00
	3 V	3.0000 V	40 Hz	2.9910	3.0090
	3 V	3.0000 V	400 Hz	2.9910	3.0090
	3 V	3.0000 V	400 Hz *	2.9910	3.0090
	3 V	3.0000 V	50 KHz	2.9100	3.0900
	30 V	12.000 V	1 KHz	11.946	12.054
	30 V	20.000 V	20 KHz	19.720	20.280
	30 V	30.000 V	50 KHz	29.100	30.900
	300 V	100.00 V	1 KHz	099.50	100.50
	300 V	200.00 V	1 KHz	199.30	200.70
	300 V	300.00 V	1 KHz	299.10	300.90

* = Filter off.

FUNC.	RANGE	INPUT LEVEL	FREQ.	DISPLAY	
				MINIMUM	MAXIMUM
RTW	3 K Ω	short	-	-	0.00010
	3 K Ω	100 Ω	-	0.09988	0.10012
	3 K Ω	1 K Ω	-	0.99970	1.00030
	30 K Ω	10 K Ω	-	09.9970	10.0030
	300 K Ω	100 K Ω	-	099.970	100.030
	3 M Ω	1 M Ω	-	0.99950	1.00050
	30 M Ω	10 M Ω	-	09.989	10.011
	300 M Ω	100 M Ω	-	098.3	101.7
RFW **	3 k Ω	short	-	-	0.00010
	3 K Ω	100 Ω	-	0.09988	0.10012
	3 K Ω	1 K Ω	-	0.99970	1.00030
	30 K Ω	10 K Ω	-	09.9970	10.0030
	300 K Ω	100 K Ω	-	099.970	100.030
	3 M Ω	1 M Ω	-	0.99950	1.00050
$^{\circ}$ C	0 $^{\circ}$ C	100 Ω **	-	- 0.2	+ 0.2

** = Use the four wire ohm cable PM9264/01

Connect the PM9264/01 to the PROBE connector of the PM 2534/2535 and the HI and LO connectors of the Fluke 5700.

Remove the leads from the V- Ω -A and 0 connector of the PM 2534/2535.

FUNC.	RANGE	INPUT LEVEL	FREQ.	DISPLAY	
				MINIMUM	MAXIMUM
Idc	30 mA	open	-		00.0015
	30 mA	+ 10 mA	-	+ 09.9955	+ 10.0045
	30 mA	+ 20 mA	-	+ 19.9925	+ 20.0075
	30 mA	+ 30 mA	-	+ 29.9895	+ 30.0105
	3 A	+ 50 mA	-	+ 0.04984	+ 0.05016
	3 A	- 50 mA	-	- 0.05016	- 0.04984
	3 A	+ 200 mA	-	+ 0.19979	+ 0.20021
	3 A	- 200 mA	-	- 0.20021	- 0.19979
	3 A	+ 2 A	-	+ 1.99670	+ 2.00330
3 A	- 2 A	-	- 2.00330	- 1.99670	
Iac	30 mA	20 mA	50 Hz	19.930	20.070
	30 mA	20 mA	400 Hz	19.930	20.070
	30 mA	20 mA	1 KHz	19.930	20.070
	3 A	2 A	50 Hz	1.9930	2.0070
	3 A	2 A	400 Hz	1.9930	2.0070
	3 A	2 A	1 KHz	1.9930	2.0070

3. CIRCUIT DESCRIPTION

3.1. EXPLANATION OF THE BLOCK DIAGRAM (refer to figure 3.2)

The PM2534 can be subdivided into three parts.

1. Analog part
2. Digital part
3. Display-keyboard part

In the analog section all signals to be measured are converted into DC voltages. These DC voltages are attenuated by a DC attenuator or amplified by a DC amplifier.

AC voltages are attenuated by an AC attenuator or amplified by an AC amplifier. The signal is converted into a DC voltage and applied to a multiplexer.

For AC/DC current measurements two shunts are used, one for 30 mA and one for 3A measurement.

For resistance measurements the PM2534 uses a programmable current source.

For °C measurements a Pt-100 temp. probe (PM9249 e.g.) must be used. The measured analog signals are multiplexed, and via an ADC and a buffer sent to the microprocessor.

The digital part has as most important; the microprocessor (8031). The microprocessor takes care, together with the software in the ROM (and RAM) that the instructions are carried out.

It communicates via I²C bus. Also there are possibilities for connecting instruments with an IEC-625 and IEEE-488 bus. System 21 can be connected as well.

In event of a microprocessor failure that mixes data and addresses the watchdog takes care of automatic initialisation. This causes an interrupt on the microprocessor.

The display is an LCD display and consist of 7 segments - and two numeric displays. It contains also status indicators.

The keyboard consists of sixteen pushbuttons to control and select the functions.

BLANK PAGE

BLANK PAGE

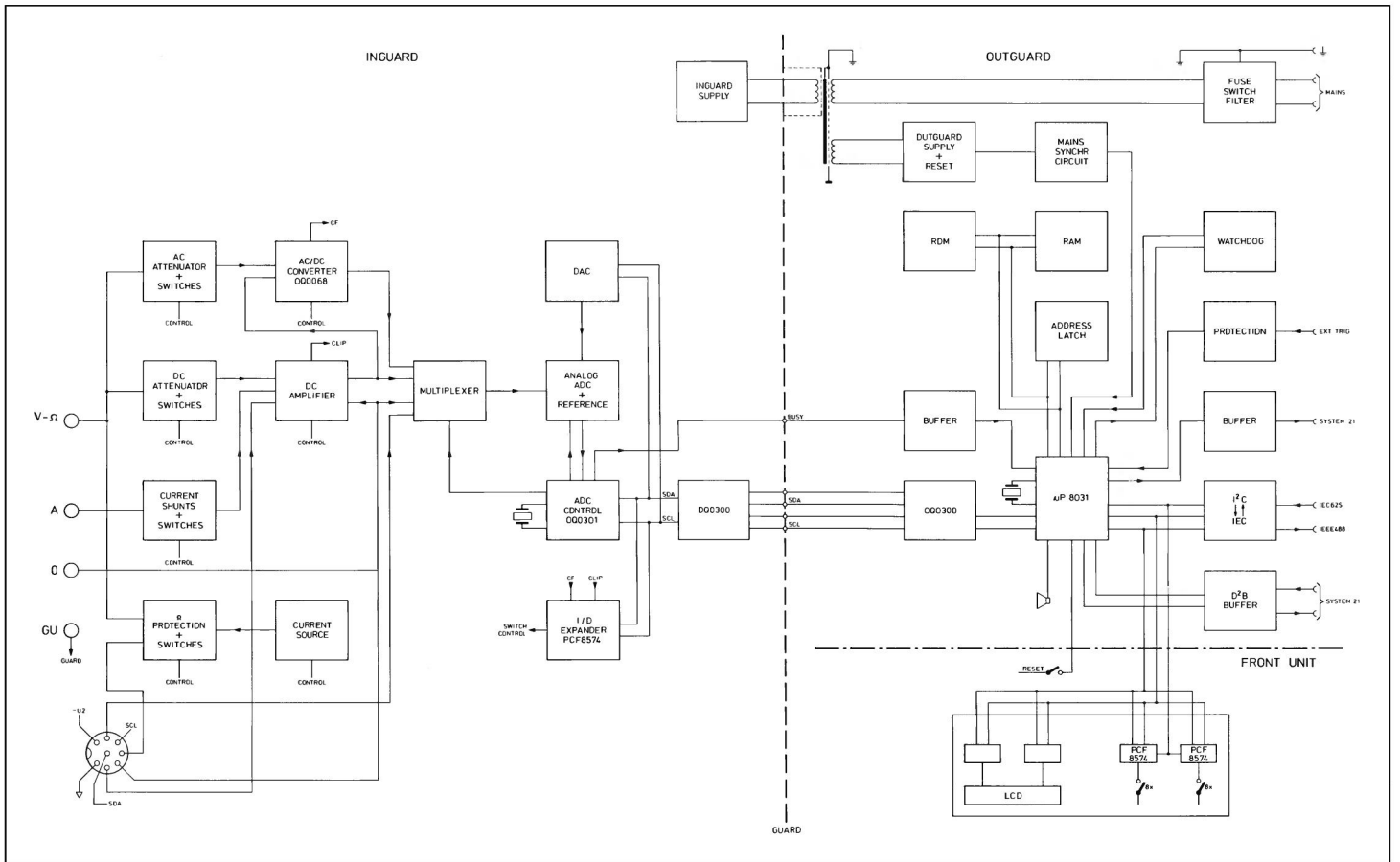

514920
860307

Figure 3.1

3.2 DETAILED DESCRIPTION

The PM2534 automatic multimeter can be subdivided into four functional sections, which are:

1. Analog section
2. Digital section
3. Interface
4. Display/keyboard section

The Analog section and the ADC are situated in the inguard section. The inguard section is the part of the instrument situated in an additional screening. The control section, display keyboard section and the interfaces are situated in the outguard section.

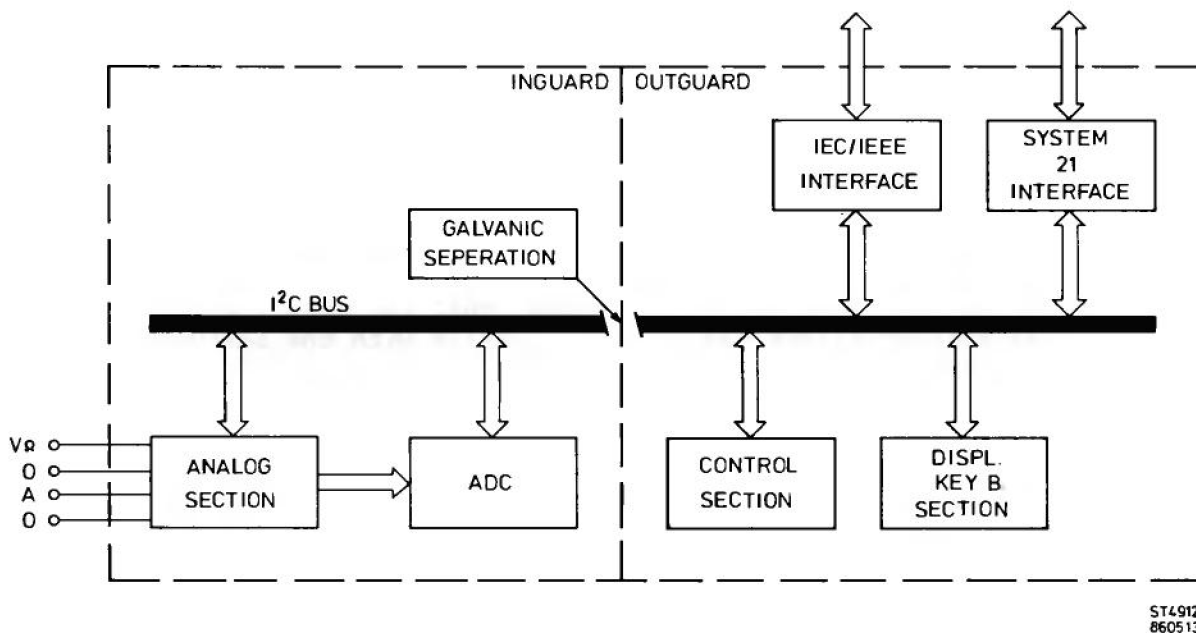

Figure 3.2 Block diagram

3.3 ANALOG SECTION

General

The analog section converts all the quantities to be measured into DC voltages which are then applied via a DC amplifier, or an AC amplifier and RMS converter, (in case of AC quantities) to the analog-digital converter (ADC).

All measuring functions are manually selected, but microprocessor controlled. The ranges can either be selected manually or automatically, also microprocessor controlled.

It is possible to start a measurement on the instrument and a provision is made to start external (TRIGGER).

3.3.1 V $\overline{\text{...}}$ measurement

The input voltage to be measured is applied to a DC attenuator and a DC amplifier:

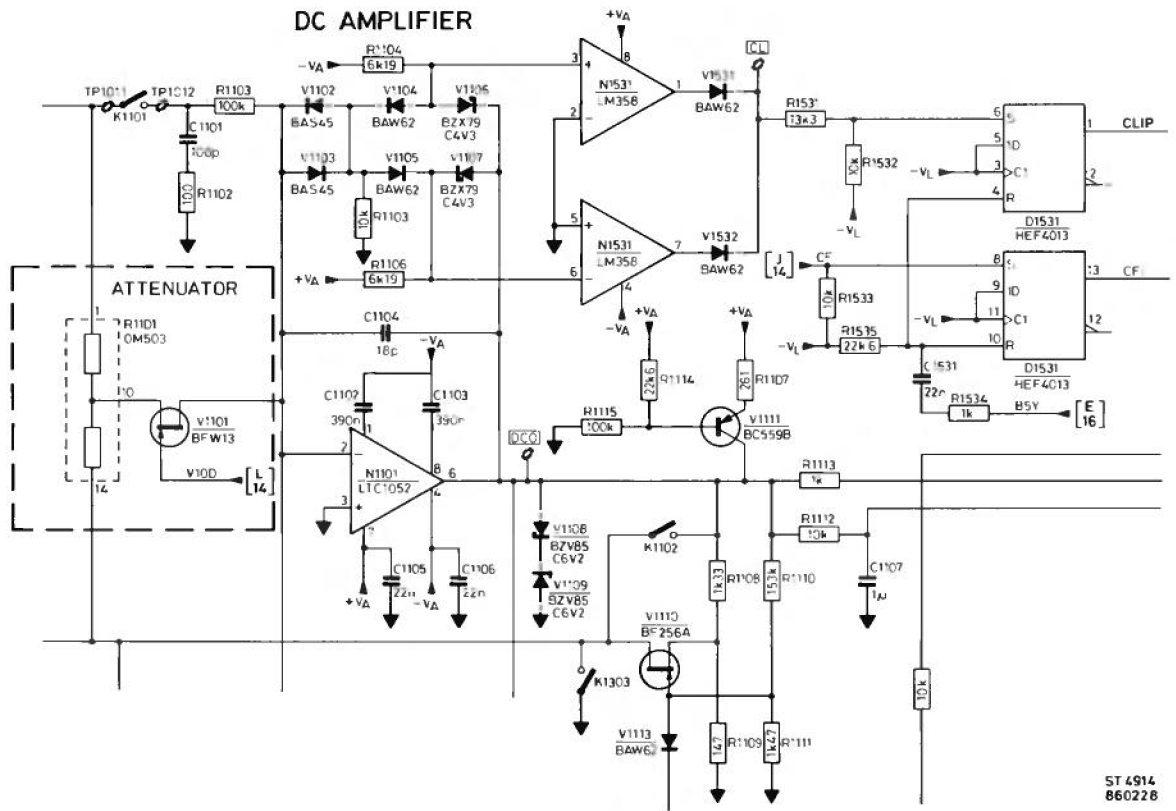

ST 4914
860228

Figure 3.3 V $\overline{\text{...}}$ measurements

The attenuator is a thin film resistor network (R1101). The attenuation is switched by FET (V1101), amplification is switched by reed relay (K1102), both are controlled by microprocessor.

The combination of attenuation and amplification gives the ranges.

Range	Attn.	GAIN DC AMPL.	Range end
300 mV	1	10	-3 V
3 V	1	1	
30 V	100	10	
300 V	100	1	

A DC voltage of -3 V is applied to the ADC at positive input voltage.

The DC amplifier is a chopper-stabilised, low drift amplifier. It uses an integrated switching oscillator to chop the DC signal into a square wave. This signal can be amplified more easily. An equivalent drift voltage of approximately $0,01 \mu\text{V}/^\circ\text{C}$ can be obtained in this way. The DC input is chopped by an electronic switch, amplified and fed back to compensate for the offset voltage due to temperature drift. The principle of the DC amplifier is shown in a simple diagram.

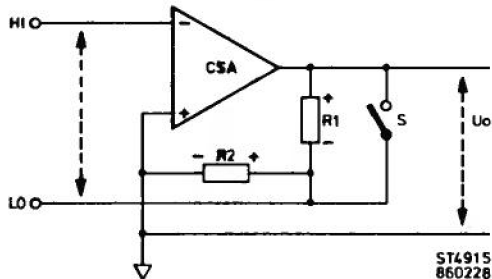

Figure 3.4 DC amplifier principle

The chopper-stabilised amplifier is a negative feedback amplifier, with a virtual earth. When the switch is open, the gain is 10, when closed, the gain is 1.

NOTE: The LO input is not connected to circuit zero.

The resistors R1108 and R1109 are used to give an amplification of 10 (K1102 open) and an amplification of 1 (K1102 closed). V1110 is closed before K1102 opens (make before break) to get always a defined amplification. R1110 and R1111 are used to give the gate of V1110 the same voltage as the source, so $U_{gs} = 0\text{V}$. The current delivered by the chopper amplifier is too low, so V1111 is used to help the chopper amplifier.

Protection.

When a higher voltage is on the input sockets, than the range allows, the voltage on pin 6 of N1101 drifts to -4,5 V or +4,5 V (depending on the polarity of the input signal).

The result is that diodes V1102, V1104 and V1106 will conduct, and the voltage on pin 6 is clamped.

When the diodes start conducting, the output of the comparator (N1531) changes and this state is kept by the flip-flop D1531. It is indicated on the display as ↑ clipping, BSY will reset this (end of measurement).

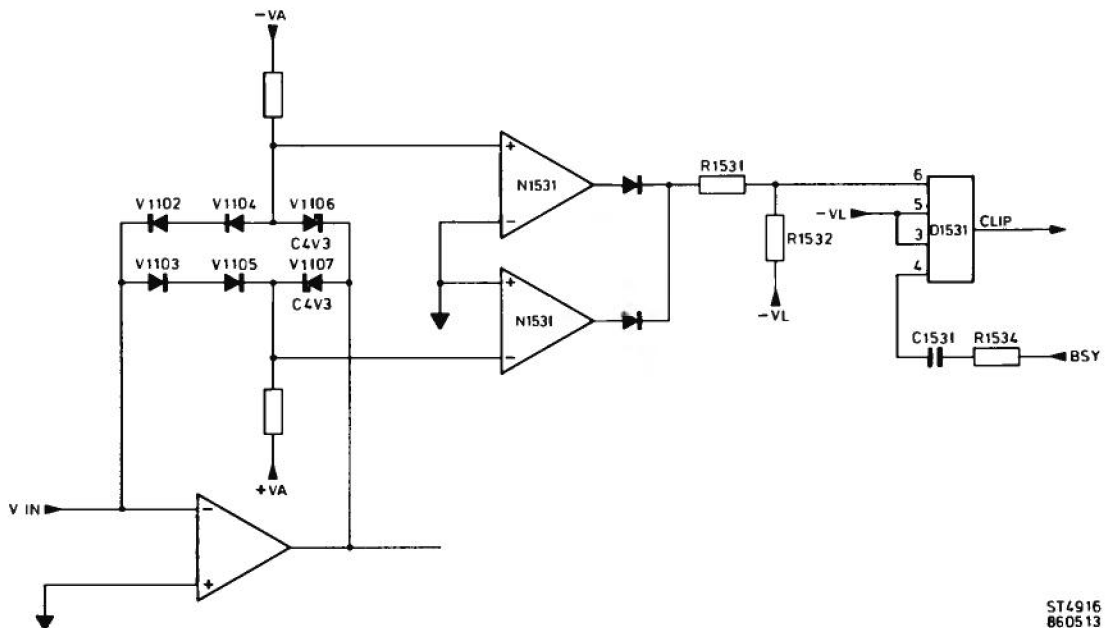

ST4916
860513

Figure 3.5 Clip indication

V~ measurement

The input voltage to be measured is applied to the AC voltage attenuator where, by means of a RC networks switched by a FET, the attenuation factor is changed (figure 3.6).

The attenuated signal is then passed to the RMS converter which produces a DC signal between 0 and 3 V depending on the RNG input.

When measuring AC voltages, the series capacitor blocks any DC input. The 100x attenuation is achieved by V1301.

RANGE	ATTN.	0Q0068 sensitivity	RANGE END
300 mV	1	300 mV	3 V
3 V	1	3 V	
30 V	100	300 mV	
300 V	100	3 V	

In the RMS converter the difference between I_1 , and I_2 is converted into current in a dual V - I converter. The current is determined by V_{in}/R and the state of the RNG signal (where R is either R1308 or R1309). This RNG selects the input sensitivity of the RMS converter. The current in the AC-to-DC converter is rectified and then converted into a current again by the RMS section. This current is proportional to the RMS value of the input signal. Capacitor C1311 and C1310 provide the automatic zero (AZC) compensation for the RMS converter. The output of the RMS converter is converted into a voltage by resistor R1310. In the RMS converter there is also an output to indicate whether the crest factor has been exceeded. When point 9 of the OQ0068 becomes logic 1, the CF (point 9) indicates via latch D1531 to the microcomputer that the crest factor is exceeded. K1303 is closed during measurement. With the filter pushbutton the measurable frequency range is shifted from 400 Hz (filter off) to 40 HZ (filter on). This is achieved with V1303 and V1304 which switch additional capacitors into the RMS circuit.

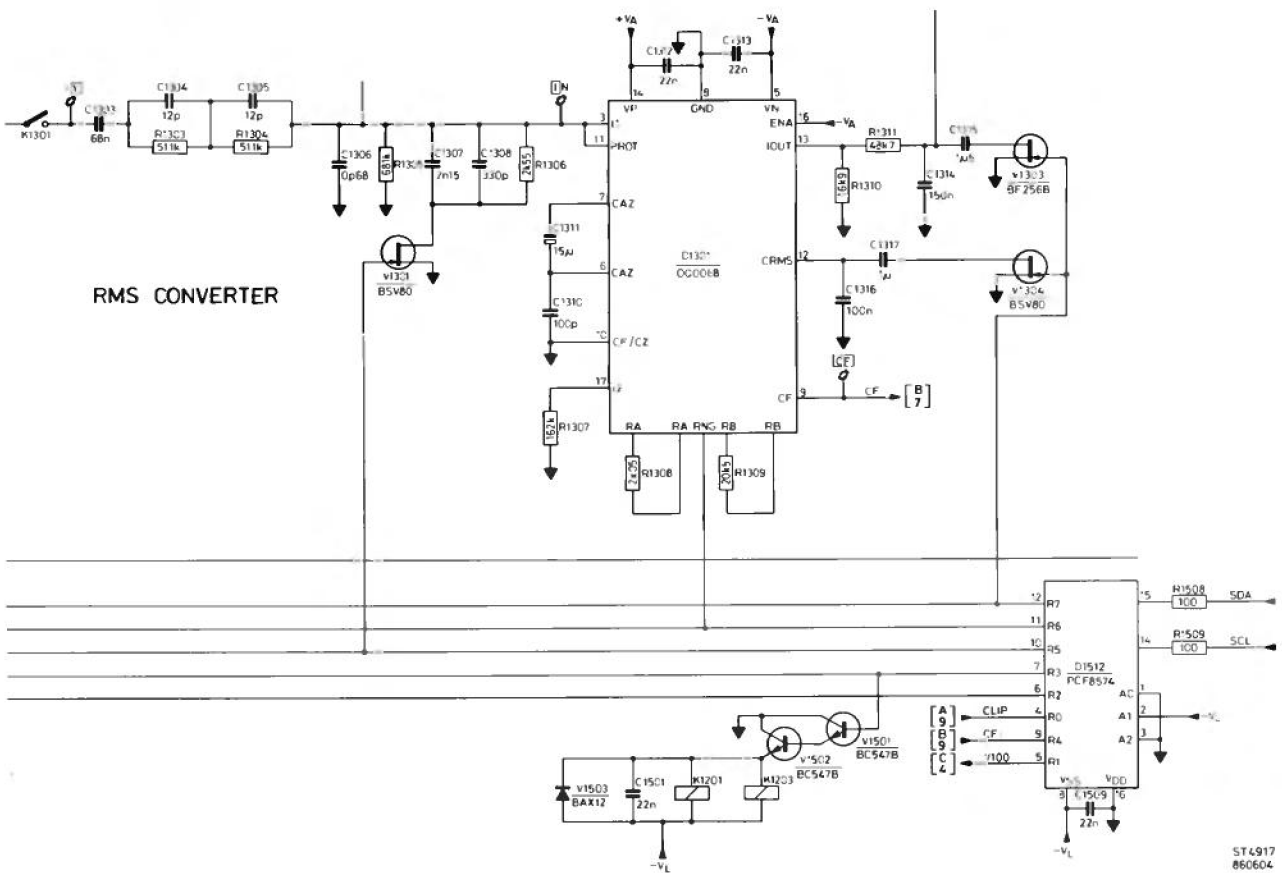

Figure 3.6 RMS converter

3.3.3 DC/AC current measurements

In the function A, two ranges are available (30 mA and 3 A). The ranges are determined by shunt R1153 and the input impedance of the ADC. The ranges are protected by fuse F1102. If the voltage across NTC R1152 becomes too high, the thyristor starts conducting and the fuse will blow.

Range	Shunt	DC ampl
+ 30 mA	150 mV	10x
+ 3 A	150 mV	10x

The AC input current ranges are shunted in the same way as the DC currents. The voltage from the shunt is supplied to the I₁ input of the RMS converter. Input I₂ of the 0Q0068 is earthed via resistor R1307.

Range	Shunt	sensitivity via 0Q0068
30 mA	150 mV	0,3 V
3 A	150 mV	3 V

3.3.4 Resistance measurement

The unknown resistance is connected between VΩ and 0 V input sockets and supplied internally by a constant current source (figure 3.7). This current results in a potential difference across the resistor that is proportional to the resistance value.

The unknown resistance may either be connected to the VΩ input socket for two wire measurements in this way, or connected in a 4-wire configuration to the Probe socket using a four-wire test lead.

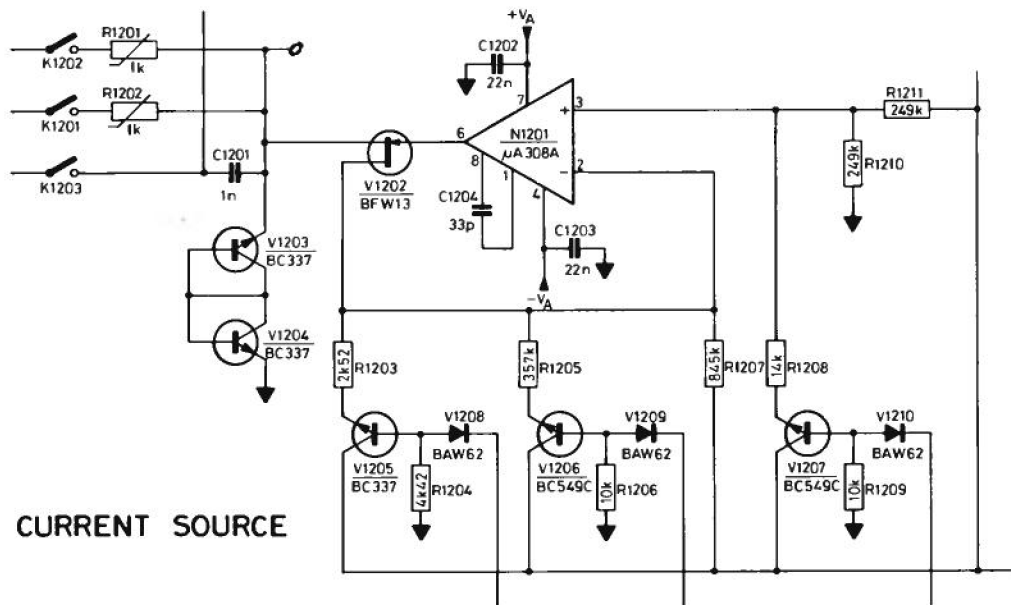

ST4968
860429

Figure 3.7 Current source

The measuring currents are derived from the current source which is built around N2101. By switching resistors in the feedback of this opamp it will change the currents.

RANGE		MEASURING CURRENT	
3	k Ω	1	mA
30	k Ω	100	μ A
300	k Ω	10	μ A
3	M Ω	1	μ A
30	M Ω	300	nA
300	M Ω	300	nA

On pin 3 half of the negative reference voltage is present. As the amplification of opamp N1201 is 1, the voltage across R1207 is $5\text{ V} : 2 = 2.5\text{ V}$. This is valid when V1207 is closed. If transistor V1207 conducts, the voltage across R1207 will decrease to 250 mV. Depending on whether transistor V1205 and/or V1206 is openend, the current through the unknown resistor is changed or constant.

For 2-wire measurement, K1202 is closed, K1201 and K1203 are closed to perform 4-wire measurements. In this case (4-wire) the resistance of the measuring leads is compensated.

3.3.5 Temperature measurement

When $^{\circ}\text{C}$ is selected, the constant current 1 mA is routed from pin 2 of the probe connector X201 or X202, which is connected via the probe to one end of the Pt-100 resistance thermometer. The other lead is connected to earth. This current gives a voltage drop which depends on the resistance value across the Pt-100 probe.

The voltage drop is measured via two other points of X201 or X202 (4-wire measurement). 0°C will give a voltage of 100 mV. The 100 mV offset is subtracted in the microcomputer so that 0°C will be displayed.

3.3.6 Multiplexer

All the measuring signals are supplied to a multiplexer. This multiplexer connects one input to the output (D1402 pin 3), depending on the code on pins 11, 10 and 9 of D4051. The signals are indirectly controlled by the μP .

3.3.7 Control of Analog Section

The selection of the analog measuring functions is made under μP control by the manually-selected or remote commands from the keyboard or interface.

Analog control actions are carried out from the μP .

These actions are performed with the aid of an I²C device (I/O expander) and a part of the OQ0301.

3.3.8 Guard circuit

The front-panel guard can be internally connected (via a switch) to a shield that isolates the 0 (Lo) input socket of the PM2534 from ground (earth).

This shield increases the impedance between the LO terminal and ground to improve common-mode rejection, which gives an improved measuring accuracy, especially for small input signal.

The guard should be connected to the same input potential as the Lo input terminal. For asymmetrical inputs, this will usually be earth.

3.3.9 Analog to Digital conversion. (ADC)

3.3.9.1 General

The ADC converts the analog quantities to be measured into their digital equivalents for measurement by the μP . The operating and timing functions for the ADC are derived from the μP via the OQ0301. The basic principle used for the ADC is the conversion of analog signals into digital form by integration (the dual slope system).

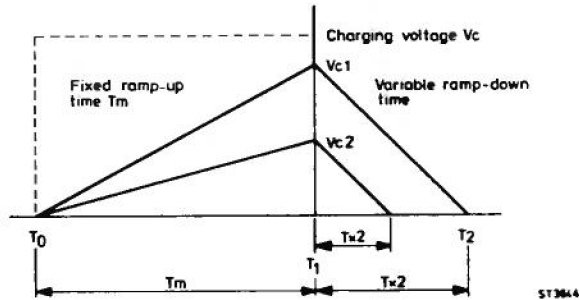

Figure 3.8 Dual slope system

3.3.9.2 ADC principle

The quantity to be measured (the unknown voltage V_x presented to the input) is applied together with a precise reference voltage via switching circuits to an integrator stage. This integrator is followed by a comparator, as shown:

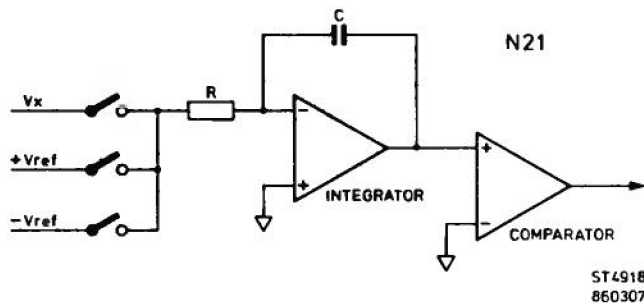

Figure 3.9 ADC principle

The integrator is charged linearly via the switch for a fixed time by an unknown voltage V_x , and then discharged over a variable time T_x by the reference voltage V_{ref} .

If the value of V_x is different, then the charging voltage amplitude is different (V_{c2}) and consequently the time taken to discharge is different. The fixed charging time T_m (ramp-up time) is measured by counting a pre-determined number of pulses in a counter (OQ0301). This counter is then used to count the number of pulses during the discharge time T_x (ramp-down time). The END of the ramp-down phase is detected by the comparator. This detection occurs as the integrator voltage reaches zero volts.

At the END of the ramp-up time, the polarity of the comparator output determines which reference voltage, $+V_{\text{ref}}$ or $-V_{\text{ref}}$ has to be chosen in the ramp-down period.

This depends on the input signal: a negative signal requires a positive reference voltage and vice versa.

3.3.9.3 Automatic zero

Incorrect Zero-crossing of the comparator can occur after the ramp-down phase because of drift offsets in the integrator and comparator circuits. This is eliminated in practice by automatic zero correction. During the AZC phase, the input of the integrator is short-circuited and any offset voltage of the integrator and comparator is loaded into a capacitor. This offset voltage is subtracted or added depending on polarity at the result.

3.3.9.4 DAC

A DAC is added in the ADC circuit to obtain higher resolution. The zero of the ADC is shifted every measurement to obtain the last digit of the reading.

Assume that the first measurement consist of 18201 points. After ten measurement the reading still will be 18201. By shifting the zero of the ADC in a positive or negative direction an extra digit is obtained. The counter which counts the pulses during the ramp-down period is stopped if the ramp-down signal crosses the zero. When the zero is next shifted the crossing will be on another point. If this is done ten times then there are also results with 18200 points. Adding these results and dividing them by 10 will give a reading with an extra digit.

In speed 1, 100 results are used in a similar way to obtain the last two digits.

3.3.10 Reference Voltage (Source + 5 V and - 5 V)

The reference voltage source circuit is shown in figure 3.10.

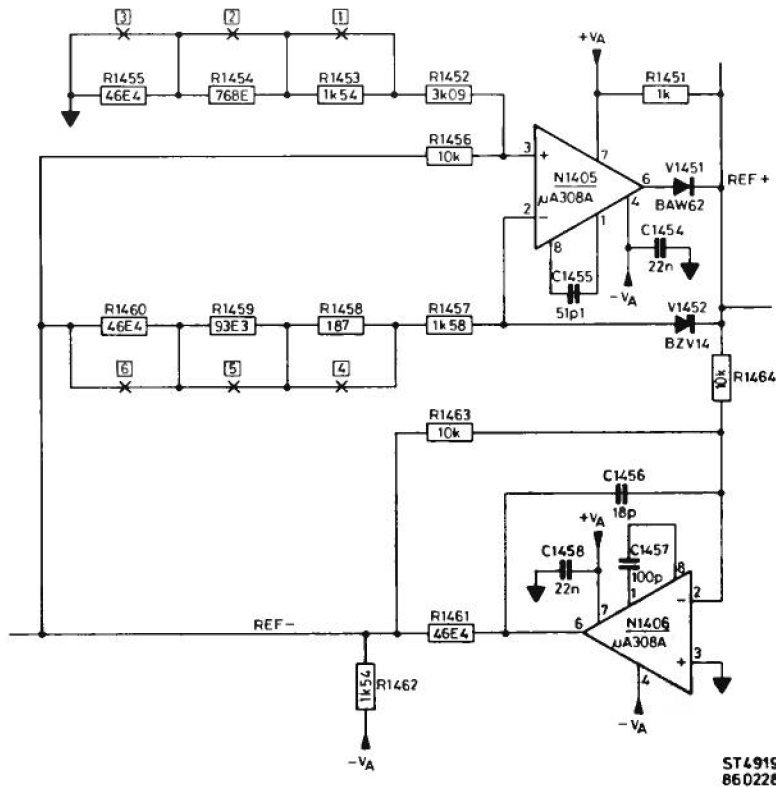

ST4919
860228

Figure 3.10 Reference Voltage

The current through V1452 must be 2 mA. This is performed with R1457, R1458, R1459 and R1460. The voltage drop is then 6,5 V with a very low temperature coefficient. The cathode of V1452 will be + 5 V, so between pin 2 and pin 3 must be 1,5 V.

The negative voltage is made with an inverter. The + 5 V is supplied to pin 2 from the N1406, and the output will be - 5 V. The resistors R1453, R1454, R1455, R1458, R1459 and R1460 are for adjustment.

3.3.11 Inguard-outguard connection

To reduce the influence of interference between the measuring circuits (INGUARD) and the digital circuits (OUTGUARD) the PM2534 is provided with a galvanic separation.

The galvanic separation consists of opto-couplers (H1802 - H1805). The communication between inguard and outguard is provided by the I²C bus.

On the bus the traffic is bi-directional. Two opto-couplers are used for the SCL line, and two opto-couplers are used for the SDA line. One optocoupler is used to indicate that the ADC is ready with a measurement. The OQ0300's are used to control the direction on the bus.

3.4 DIGITAL SECTION

The PM2534 uses the 8031 microcomputer and one ROM in the digital part to control the multimeter.

(For details of the 8031 refer to section 3.7.1)

3.4.1 Software description

The software carries out some routines to measure and evaluate the applied input signal. The main tasks of the software are mentioned here:

1. Output/input to the IEEE-488/IEC-625 interface.
2. Carry out the different trigger modes.
3. Perform the status byte.
4. Translate the input of the interface to a internal code.
5. Carry out all System 21 actions.
6. Read the function switch, data-hold probe etc.
7. Measure the input signal.

The last action can be subdivided into the following flow-chart.

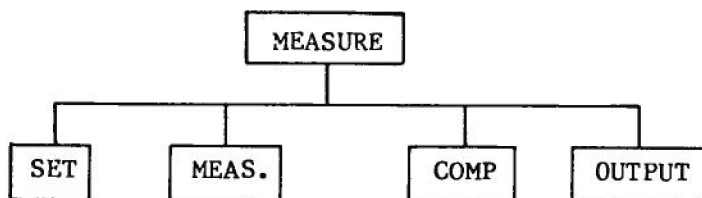

Figure 3.11 Flow chart

The routines outlined in the main flow-chart can be outlined as follows.

SET-UP routine	This routine sets-up the OQ 0301. The microcomputer reads the calibrated value out of the RAM and sends it to the OQ 0301. The relay and FET switches in the analog part are set.
Measure routine	In this routine the PM2534 is measuring. It starts the measurement and collects the counts of the OQ 0301.
Calculate routine	This routine obtains the final measuring value from the following calculations. The following calculations may be made: <ul style="list-style-type: none"> - Calculate the temperature in the °C function (linearisation) - Calculate with the offset (subtract from measured value)
Output routine	The output routine translates the measure result to ASCII for display or interfaces.

3.4.2 RAM/ROM

The PM2534 has a 2 K or 8 K RAM (see Modifications 11.1 :9). In this RAM all the calibration values are stored. A battery G1601 supplies the RAM if the power is switched off. In the PM2535 a RAM of 8 kbytes is used. In this RAM, additional information is stored like burst measurements and sequence parameters.

The PM2534 has a 16 or 32 K ROM (see Modifications 11.1 :7), in the PM2535 a 32 K ROM is used.

External trigger circuit

Via the external trigger input a measurement can be started. When the input is pulled down, a pulse on pin 9 of D 1802 will interrupt the processor. After the interrupt, the processor starts a new measurement.

3.4.3 I²C bus

The I²C bus differs considerably from the conventional bus structures in that data-transfer is effected in a bit-serial, rather than in byte-parallel format.

In a conventional microcomputer such as the 8048 for instance, 12 address, 8 data and 4 control lines are necessary for parallel data transfer. The I²C 8440 microcomputer on the other hand requires only 2 lines to transfer serially the same amount of data. Chips used for ADC, RAM and LCD drivers are I²C compatible and also use the same two lines.

These two lines are respectively the SDL (serial data line) and the SCL (serial clock line), the function of which is to synchronise data-transfer between the appropriate I²C devices.

Almost any number of devices can be connected to the I²C bus. Each device is allocated its own specific 7-bit address which enables any two of these devices to communicate with each other upon receipt of a message prefixed with the appropriate 7-bit address.

This specific 7-bit address usually comprises a fixed address part (4 bits) and a user definable part (3 bits).

The latter is assignable by tying "Define Address" pins to high or low levels.

Address recognition is effected in the I²C interface hardware of each device and this eliminates the need for decoding logic. The use of an automatically invoked arbitration procedure, which prevents two or more devices from transmitting simultaneously, makes I²C technology eminently suitable for a multiprocessor system.

For further information about I²C see: Philips Data Handbook: Integrated circuits for digital systems in radio, audio and video equipment.

3.5 IEEE/IEC INTERFACE

The IEEE/IEC interface processor communicates with the main processor via the I²C bus. It acts as a slave of the main processor. This interface processor handles the complete handshake of the IEC/IEEE interface.

3.5.1 Receiving

If the system controller sends a listen address (MLA) via the DIO lines (ATN is true), D1905 and D1906 are switched to the receive direction. Also via the hardware NDAC (no data accepted) is generated. The TA (talker active) signal is high so that the input of D1905 and D1906 (Special GPIB devices) is low. This means that a part of D1906 acts as input and another part as output.

D1906 iutputs: NDAC, NRFD, SRQ

D1906 inputs: DAV, REN, ATN, EOI, IFC

Then the microcomputer starts handshaking the device address on the bus. If the device address on the bus is the same as the device address selected, the microprocessor starts to handshake in the other data bytes.

3.5.2 Transmitting

After the microcomputer has received MTA (my talk address) or in talk-only mode as described, the interface becomes talker. This means that D1905 and D1906 are now transmitters. The bytes on P0 are now data for the controller. If the interface becomes talker, it makes P13 low.

The GPIB device D 1906 is switched to the following configuration.

D1906 outputs: DAV, SRQ, EOI

D1906 inputs: NDAC, NRFD, REN, ATN, IFC

The PM2534 is now handshaking so that the bytes are sent to a controller or another device. At the end of the databytes the PM2534 generates EOI. The interface will remain talker until the Listener address is again on the bus, or after an IFC command is connected to the interrupt system of the interface.

3.6 DISPLAY/KEYBOARD

The PCF 8576 is a circuit designed to drive a Liquid Crystal Display with up to 160 segments. A 2-line I²C bus structure enables serial data transfer with the microcomputer.

A LCD is an AC device. Therefore, for multiplexing, the information of the segment line is important for each segment that will be driven by that line.

The reference voltage for the driver is obtained from transistor V2102 and zener diode V2101.

To change the viewing angle the reference voltage can be adjusted with potentiometer R2105.

On the same PCB the keyboard is situated. Pushing a switch will be read by the microcomputer via the I²C bus. This is done by scanning lines P0 to P7 to obtain which switch is pressed.

3.7 DATA OF COMPONENTS

3.7.1 8031AH single-component 8-bit microcomputer

- 8031AH - Control-Oriented CPU with RAM and I/O
- 128K Accessible External Memory
- 218 User Bit-Addressable Locations
- 128 x 8 RAM
- 32 I/O Lines (Four 8-Bit Ports)
- Two 16-Bit Timer/Counters
- Programmable Full-Duplex Serial Channel

The 8031AH is Intel's HMOS version of the High performance 8-bit 8031 microcomputer. While the 8031AH features the same powerful architecture and instruction set as its HMOS predecessor, it offers the additional benefit of lower power supply current.

The 8031AH provides a cost-effective solution for those controller applications requiring up to 64 Kbytes of program and/or 64 Kbytes of data storage. Specifically, the 8031AH contains 128 bytes of read/write data memory; 32 I/O lines configured as four 8-bit parallel ports; two 16-bit timer/counters.

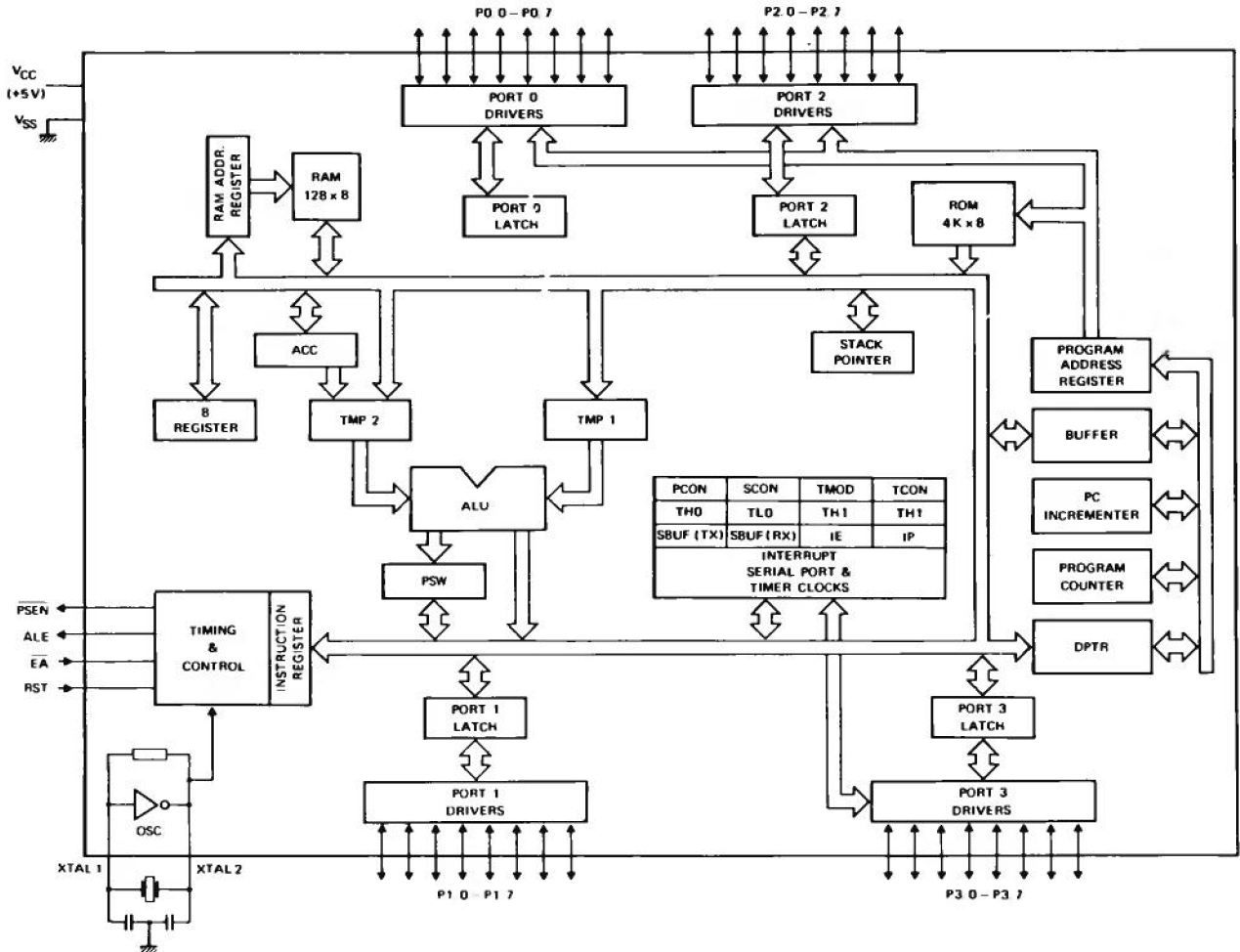

Figure 3.12 Block Diagram

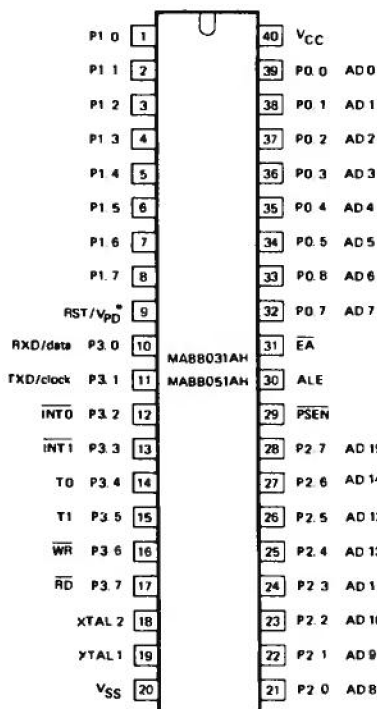

Figure 3.13 Pin Configuration

8031AH PIN DESCRIPTIONS

V_{SS}
Circuit ground potential.

V_{CC}
5V power supply input for normal operation and program verification.

Port 0

Port 0 is an 8-bit open drain bidirectional I/O port. It is also the multiplexed low-order address and data bus when using external memory. It is used for data output during program verification. Port 0 can sink (and in bus operations can source) eight LS TTL loads.

Port 1

Port 1 is an 8-bit quasi-bidirectional I/O port. It is also used for the low-order address byte during program verification. Port 1 can sink/source four LS TTL loads.

Port 2

Port 2 is an 8-bit quasi-bidirectional I/O port. It also emits the high-order address byte when accessing external memory. It is used for the high-order address and the control signals during program verification. Port 2 can sink/source four LS TTL loads.

Port 3

Port 3 is an 8-bit bidirectional I/O port with internal pullups. It also serves the functions of various special features of the MCS-51 Family, as listed below:

Port Pin	Alternate Function
P3.0	RXD (serial input port)
P3.1	TXD (serial output port)
P3.2	INT0 (external interrupt)
P3.3	INT1 (external interrupt)
P3.4	T0 (Timer/counter 0 external input)
P3.5	T1 (Timer/counter 1 external input)
P3.6	WR (external Data Memory write strobe)
P3.7	RD (external Data Memory read strobe)

The output latch corresponding to a secondary function must be programmed to a one (1) for that function to operate. Port 3 can sink/source four LS TTL loads.

RST

A high on this pin for two machine cycles while the oscillator is running resets the device. A small external pulldown resistor ($\approx 8.2k\Omega$) from RST to V_{SS} permits power on reset when a capacitor ($\approx 10\mu F$) is also connected from this pin to V_{CC} .

ALE

Address Latch Enable output for latching the low byte of the address during accesses to external memory. ALE is activated at a constant rate of 1/6 the oscillator frequency except during an external data memory access at which time one ALE pulse is skipped. ALE can sink/source 8 LS TTL inputs.

PSEN

The Program Store Enable output is a control signal that enables the external Program Memory to the bus during external fetch operations. It is activated every six oscillator periods except during external data memory access. PSEN remains high during internal program execution.

EA

When held at a TTL high level, the 8051AH executes instructions from the internal ROM when the PC is less than 4096. When held at a TTL-low level, the 8031AH/8051AH fetches all instructions from external Program Memory. Do not float EA during normal operation.

XTAL 1

Input to the inverting amplifier that forms part of the oscillator. This pin should be connected to ground when an external oscillator is used.

XTAL 2

Output of the inverting amplifier that forms part of the oscillator, and input to the oscillator signal when an external oscillator is used.

3.7.2 MAF 8441 single-chip 8-bit microcontroller

DESCRIPTION

The MAB/F8441 is a device with 4K ROM/128 RAM bytes plus 8-bit LED-driver

It has 20 quasi-bidirectional I/O port lines, one serial I/O line, one single-level vectored interrupt, an 8-bit timer event counter and on-board clock oscillator and clock circuits.

This microcontroller is designed to be an efficient controller as well as an arithmetic processor. The microcontrollers have extensive bit handling abilities and facilities for both binary and BCD arithmetic.

For detailed informations see the "Users manual Single-chip microcomputers".

Features:

- 8-bit: CPU, ROM, RAM and I/O in a single 28-lead DIL package
- 128 RAM bytes
- 20 quasi-bidirectional I/O port lines
- Two testable inputs: one of which can be used to detect zero cross-over, the other is also the external interrupt input
- Serial I/O that can be used in single or multi-master systems (serial I/O data via an existing port line and clock via a dedicated line)
- Internal oscillator, generated with inductor, crystal, ceramic resonator or external source
- Over 80 instructions all of 1 or 2 cycles
- Single 5 V power supply ($\pm 10\%$)

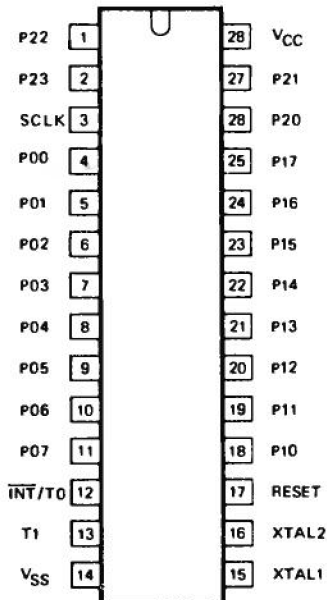

Figure 3.14 Pinning

PINNING	DESIGNATION	
V _{SS}	14	Ground
V _{CC}	28	Power supply, + 5 V
P00-P07	4-11	Port 0, 8-bit quasi-bidirectional I/O port
P10-P17	18-25	Port 1, 8-bit quasi-bidirectional I/O port
P20-P23	26, 27, 1, 2	Port 2, 4-bit quasi-bidirectional I/O port; P23 is the serial data I/O in serial I/O mode
SCLK	3	Bidirectional clock for serial I/O
INT/T0	12	External interrupt input (sensitive to a negative-going edge min LOW > 7 clock pulses, min HIGH > 4 clock pulses), testable using the JTO or JNT0 instructions.
T1	13	Input pin, testable using the JT1 or JNT1 instructions. It can be designated as event counter input using the STRT CNT instruction. It can also be used to detect zero cross-over of slowly moving AC inputs.
RESET	17	Input to initialize the processor (active HIGH).
XTAL1	15	Connection to timing component (crystal) that determines the frequency of the internal oscillator. It is also the input for an external clock source.
XTAL2	16	Connection to other side of the timing component.

3.7.3 D/A convertor DAC-08 E

DESCRIPTION

The DAC-08 series of 8-bit monolithic digital-to-analog converters provide very high-speed performance coupled with outstanding applications flexibility.

Advanced circuit design achieves 85ns setting times with very low "glitch" energy and at low power consumption.

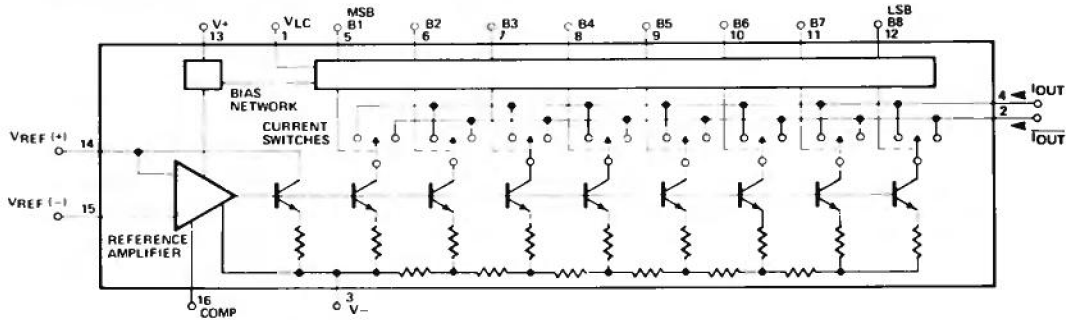

Figure 3.15 Block diagram

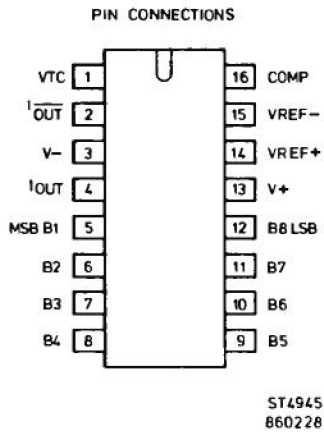

Figure 3.16 Pin connections

3.7.4 TL7705A, supply voltage supervisor (watchdog)

- Power-On Reset Generator
- Automatic Reset Generation After Voltage Drop
- Wide Supply Voltage Range ... 3 V to 18 V
- Precision Voltage Sensor
- Temperature-Compensated Voltage Reference
- True and Complement Reset Outputs
- Externally Adjustable Pulse Width

Description

The TL7702A series are monolithic integrated circuit supply voltage supervisors specifically designed for use as reset controllers in microcomputer and microprocessor systems. During power-up the device tests the supply voltage and keeps the RESET and RESET outputs active (high and low, respectively) as long as the supply voltage has not reached its nominal voltage value. Taking RESIN low has the same effect. To ensure that the microcomputer system has reset, the TL7702A then initiates an internal time delay that delays the return of the reset outputs to their inactive states. Since the time delay for most microcomputers and microprocessors is in the order of several machine cycles, the device internal time delay is determined by an external capacitor connected to the D_T input (pin 3).

$$t_d = 1.3 \times 10^4 \times C_T$$

Where: C_T is in farads (F) and t_d is in seconds(s)

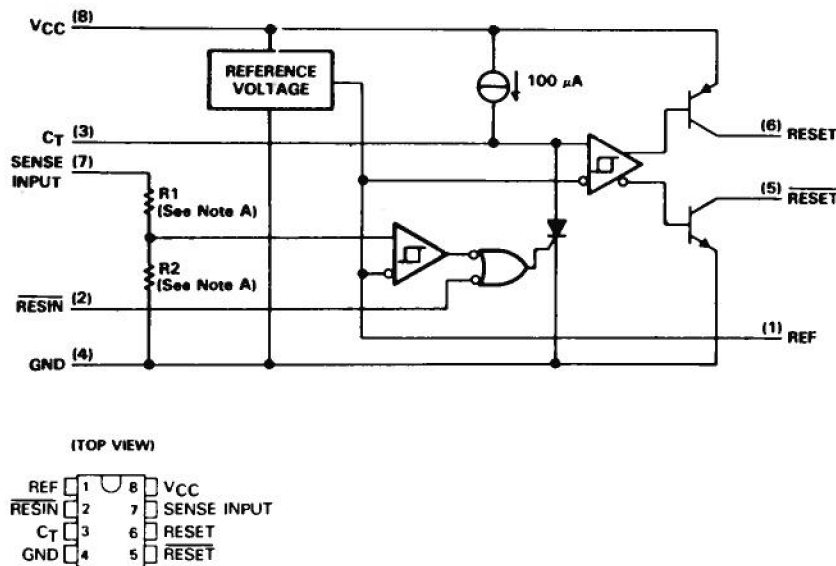

Figure 3.17 Functional block diagram

3.7.5 OM 503 Thin Film resistor network

This is a specially-made resistor network.

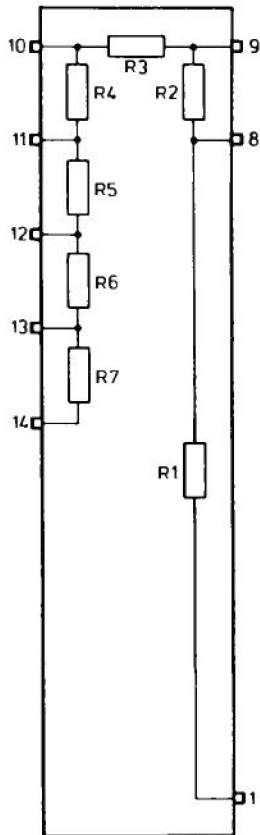

Figure 3.18

Resistor values

Name	nom. value	abs. tol.
R1	8998K	0,8 %
R2	4K668	2 %
R3	898K	0,95 %
R4	518E4	2 %
R5	89K78	0,95 %
R6	52K32	2 %
R7	9K98	0,95 %

3.7.6 SA 1045 P D²B driver comparator circuit

FUNCTION : Driver comparator Circuit
for Domestic Digital Bus
D²B.

PACKAGE : 8 pins plastic DIL SOT97C.1

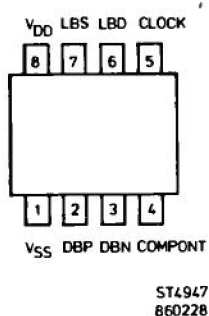

Figure 3.19

PINNING

PIN	SIGNAL	TYPE
1	V _{SS}	0 V Supply
2	DBP	ODP/CI IP Input
3	DBN	ODN/CI CI Comparator Input
4	Compout	OP OP Push-pull Output
5	clock	IP ODN Open Drain N-output
6	LBD	IP ODP Open Drain P-output
7	LBS	OP
8	V _{DD}	+ Supply

The driver / detector chip consists of 3 main blocks:

- 1- analog driver / detector
- 2- digital filter
- 3- power-on-reset

1. The analogue driver / detector is a copy of the same part in the D²B-IC. It performs the driving and sensing of the D²B-lines. The sensing happens on certain levels with a certain hysteresis over a high common-mode-range. The driver is either tri-state or puts defined levels on the lines. This part meets the electrical D²B-specification.
2. The digital filter cannot follow high frequent changes on the bus lines and so performs the necessary noise-reduction. The input data must be stable within 2 clocks or it is not taken in.
3. The power-on-resets the whole chip at power-on. It resets the filter and switches off the analogue part.

The driver can be controlled by signal LBD, the output of the detection is LBS. DBN and DBP is the bus line I/O and Compout is the direct comparator output.

3.7.7 OQ0300 bus control

Description

The OQ0300 consists of two equal circuits with a common supply current source and voltage reference.

Each of these equal circuits interfaces one of the I²C bus lines to a pair of opto-couplers. One of these couplers transmits the I²C information to the other side of the galvanic separation while the other coupler receives information from the other side of the galvanic separation.

In case of a multimaster system, attention should be given to the the over all propagation delay of the galvanic separation.

The OQ0300 can be adapted to the dark current - light current ratio of the photodiode used in the optocoupler.

The enable input enables both LED driver stages.

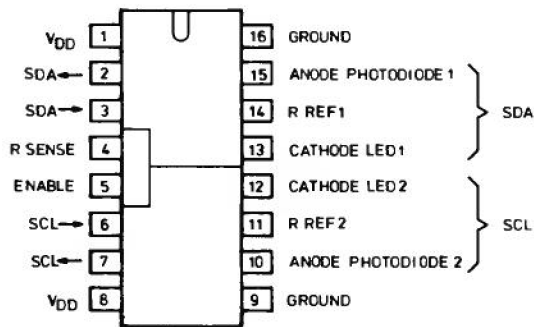

ST4948
860228

Figure 3.20 Pinning

3.7.8 OQ 0301 ADC Control

General

The OQ0301 is designed as an ADC control circuit for a 3-phase integrating ADC system with I²C compatible serial data transfer. It contains three 24-bit serial in-parallel out shift register, a 23-bit synchronous counter which can be parallel loaded from one of the 3 shift-registers, a 24-bit parallel in-serial out shift-register for reading the result of the counter and a full comparator for timing possibilities of the counter.

Further, it contains the ADC-control logic for controlling a 3-phase integrating ADC circuit and a clock oscillator controlled by an external crystal.

The OQ0301 has an I²C-interface (with slave control).

The timing for the several phases is done by the OQ0301 and also the counting of clock pulses for the result of an ADC cycle:

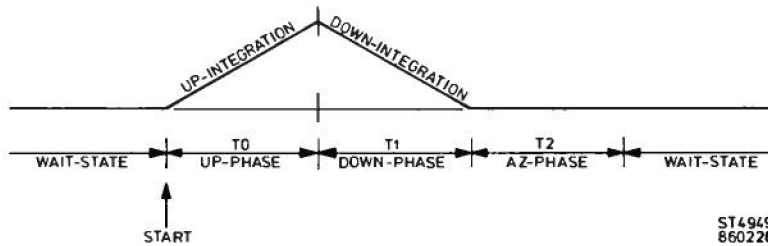

Figure 3.21

If the ADC control is in the WAIT-state a start can be generated and the ADC control starts the UP-phase. The timing of the UP-phase is done by presetting a 23-bit synchronous upcounter and by upcounting until the counter is full.

Then the DOWN-phase is started. In the DOWN-phase the counter counts the clock pulses to get the result and is stopped by a COMP(arator) signal, which comes from the analog ADC-circuit. If in case of a fault the DOWN-phase is not stopped by the COMP signal, it will be stopped when the counter is full (therefore the counter is also pre-settable for the DOWN-phase to get a defined max. DOWN-timing in case of a fault). When the DOWN-phase is ready, the contents of the counter is transferred to the output shiftregister and the AZ-phase is started. The timing of the AZ-phase is done by presetting the counter and then by upcounting until the counter is full. After the AZ-phase is done, the ADC control goes to the WAIT-state and the next ADC-cycle can be started.

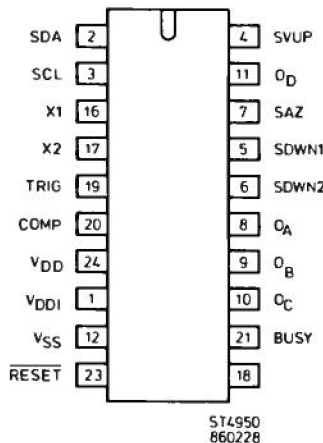

Figure 3.22 Pinning

Inputs	
SDA SCL X1 X2	I ² C-BUS CRYSTAL INPUTS FOR INTERNAL OSCILLATOR AND ALSO FOR INPUT OF EXTERNAL CLOCK
TRIG	TRIGGER INPUT
COMP	COMPARTOR INPUT (FROM ADC)
RESET	RESET OQ0301 (SAME AS POWER ON)
V _{DD} V _{DDI} V _{SS}	SUPPLY

Outputs	
SVUP SAZ SDWN1 SDWN2	ADC CONTROL LINES
O _A O _B O _C O _D	OUTPUTS OR ADC CONTROL LINES (SELECTABLE)
BUSY	OUTPUT LINE FOR DIRECT BUSY OR READY CONTROL

3.7.9 SAA1300 tuner switching circuit

The SAA1300 is used for switching on and off the supply lines of various circuit parts via an I²C bus signal. It contains 5 output stages which are capable of supplying up to 100 mA in the ON state or sinking up to - 100 μ A in the OFF state. Current limiting and short-circuit protection are included.

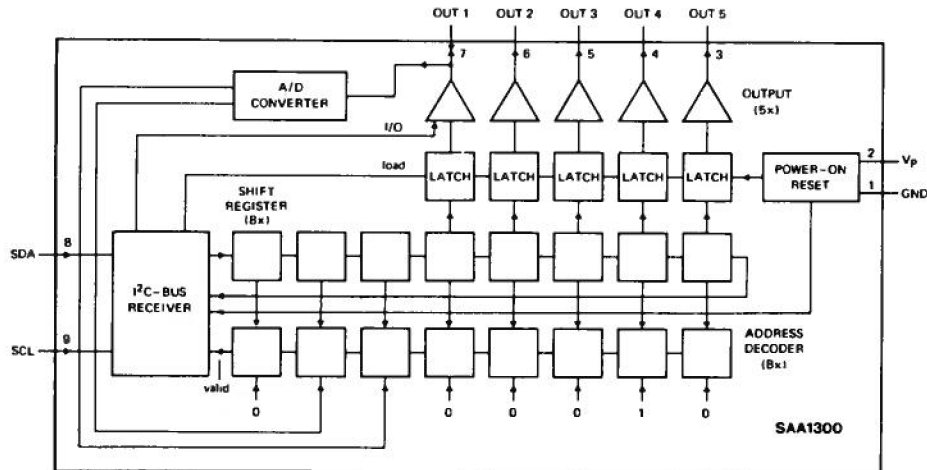

Figure 3.23 Block diagram

PINNING

pin no.	symbol	function
1	GND	ground
2	V _p	positive supply
3	OUT5	outputs
4	OUT4	
5	OUT3	
6	OUT2	
7	OUT1	
8	SDA	} I ² C bus
9	SCL	

3.7.10 PCF8574 remote 8-bit I/O for I²C bus

DESCRIPTION

The PCF8574 is a single-chip silicon gate CMOS circuit. It provides remote I/O expansion for the MAB8400 and PCF8500 microcomputer families via the two-line serial bidirectional bus (I²C). The device consists of an 8-bit quasi-bidirectional port and an I²C interface. The PCF8574 has low current consumption and includes latched outputs with high current drive capability for directly driving LEDs.

Features

- Operating supply voltage 2,5 V to 6 V
- Bidirectional expander
- Open drain interrupt output
- 8-bit remote I/O port for the I²C bus
- Latched outputs with high current drive capability for directly driving LEDs
- Address by 3 hardware address pins for the use of up to 8 devices (up to 16 possible with mask option)

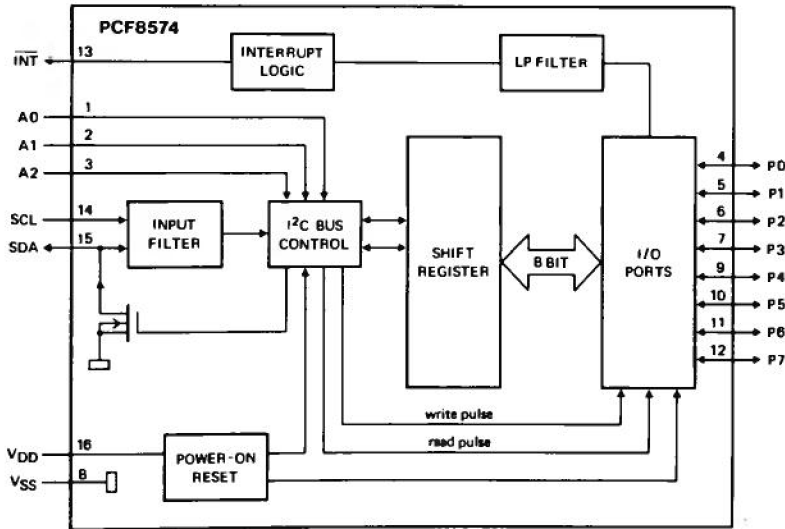

Figure 3.24 Block diagram

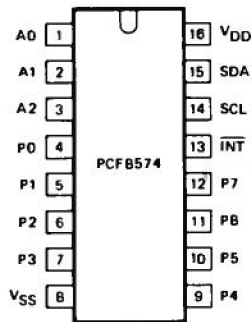

Figure 3.25 Pinning diagram

1 to 3	A0 to A2	address inputs
4 to 7	P0 to P3	8-bit quasi-bidirectional I/O port
9 to 12	P4 to P7	
8	V _{SS}	negative supply
13	INT	interrupt output
14	SCL	serial clock line
15	SDA	serial data line
16	V _{DD}	positive supply

3.7.11 OQ0068A AC/DC convertor (RMS)

DESCRIPTION

The OQ0068 is an integrated AC voltage to DC current converter for use in measuring equipment. The output current is proportional to the RMS value of the input voltage.

Special features are:

- Enable input for power-down mode
- Range input for selection of 2 resistor programmed ranges
- Crest Factor or Zero Crossing output selection
- Low leakage input clamp
- Automatic offset compensation

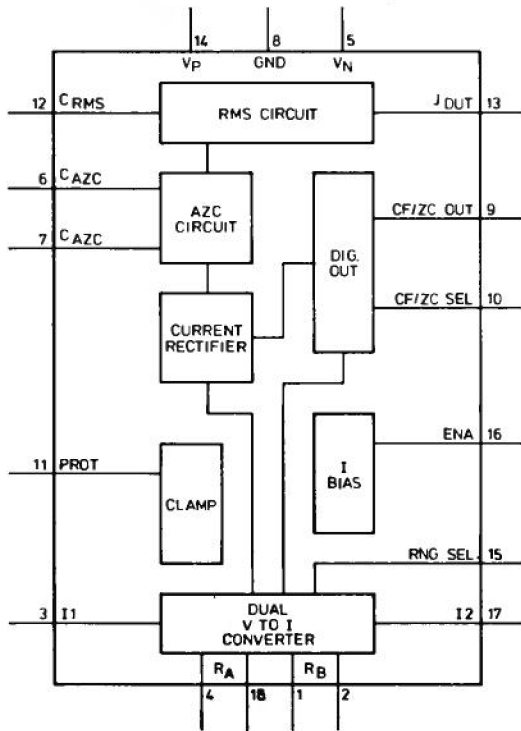
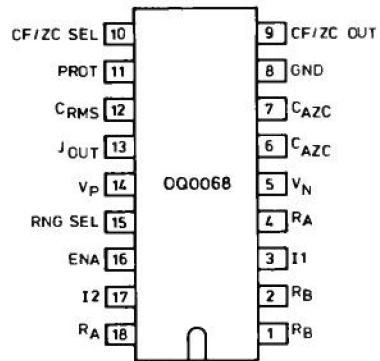

Figure 3.26 Block diagram OQ0068A



ST4470
840727

Figure 3.27 Pinning OQ0068A

OPERATION MODES

ENA	SEL	CF/ZC	SEL RNG	FUNCTION
1		X	X	Power-down mode
0		1	0	Low range measurement mode
0		1	1	High range measurement mode
0		0	0	Low range Counter mode
0		0	1	High range Counter mode

PIN DESCRIPTION

- | | |
|--|---|
| <p>1 RB Range resistor B</p> <p>2 RB Range resistor B</p> <p>3 I1 Input 1</p> <p>4 RA Range resistor A</p> <p>5 VN Negative supply</p> <p>6 CAZ Autozero capacitor</p> <p>7 CAZ Autozero capacitor</p> <p>8 GND Ground</p> <p>9 CF/ZC OUT Digital output</p> | <p>10 CF/ZC SEL Digital output select</p> <p>11 PROT Input protection clamp</p> <p>12 CRMS Integrating capacitor</p> <p>13 IOUT Current output</p> <p>14 VP Positive supply</p> <p>15 RNG SEL Range selection</p> <p>16 ENA Enable input</p> <p>17 I2 Input 2</p> <p>18 RA Range resistor A</p> |
|--|---|

3.7.12 Linear LTC1052 chopper-stabilized operational amplifier

DESCRIPTION

The LTC1052 are low noise chopper-stabilized opamps manufactured using Linear Technology's enhanced LTCMOSTM silicon gate process. Chopper-stabilization constantly corrects offset voltage errors. Both initial offset and changes in the offset due to time, temperature and common-mode voltage are corrected. This, coupled with picoampere input currents, gives these amplifiers unmatched performance.

Low frequency (1/f) noise is also improved by the chopping technique. Instead of increasing continuously at a 3dB/octave rate, the internal chopping causes noise to decrease at low frequencies.

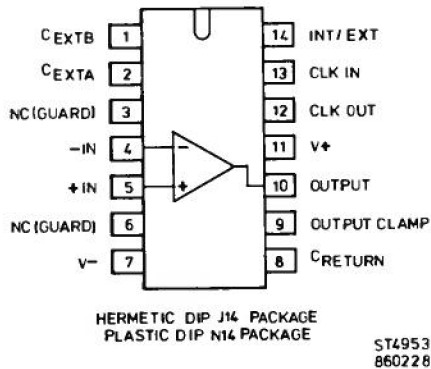

Figure 3.28 Pin connections

4. DISMANTLING THE INSTRUMENT

GENERAL INFORMATION

This section provides the dismantling procedures required for the removal of components during repair operations. All circuit boards removed from the instrument must be adequately protected against damage, and all normal precautions regarding the use of tools must be observed. During dismantling a careful note must be made of all disconnected leads so that they can be reconnected to their correct terminals during re-assembly.

CAUTION: Damage may result if:

- the instrument is switched on when a circuit board has been removed.
- a circuit board is removed within one minute after switching-off the instrument.

Disconnect measuring terminals before opening.

4.1 REMOVING THE COVER (Figure 4.1)

- Remove the fixing screws (rear and bottom of the instrument)
- Pull the cover back from the front
- Remove the plastic connecting rails

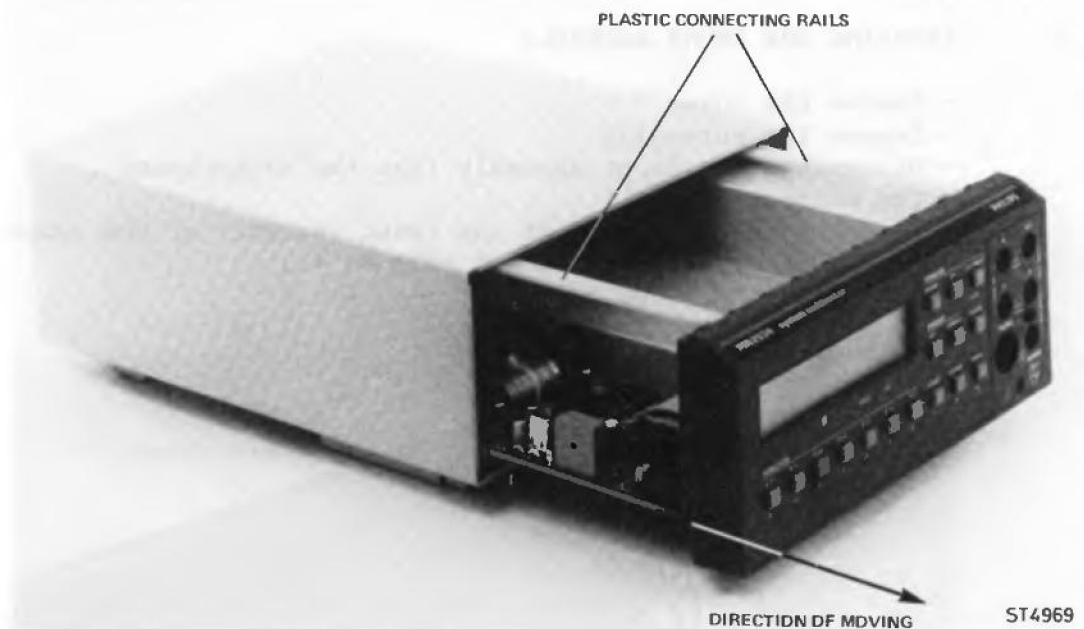

Figure 4.1

4.2 REMOVING THE TOP SCREENING (Printed circuit board, component side)

- Remove the cover
- Remove the two fixing screws of the screening (bottom)
- Push the screening in the direction of the front (figure 4.2 arrow 1)
- Lift up the screening (figure 4.2 arrow 2)

4.3 REMOVING THE BOTTOM SCREENING (Printed circuit board, conductor side)

- Place the instrument upside down
- Push screening in the direction of the rear (figure 4.2 arrow 3)
- Lift up screening (figure 4.2 arrow 4)

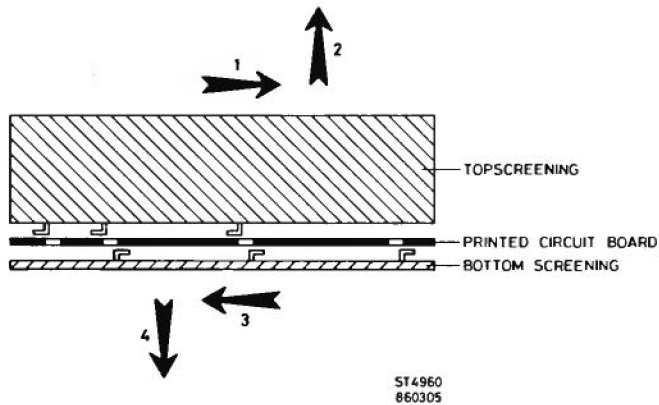

Figure 4.2

4.4 REMOVING THE FRONT ASSEMBLY

- Remove the cover
- Remove the screening
- Disconnect the front assembly from the motherboard (by connector X2101)
- Bend out the two hooks of the front assembly at the component side of the printed circuit board (figure 4.3)
- Pull back the front assembly

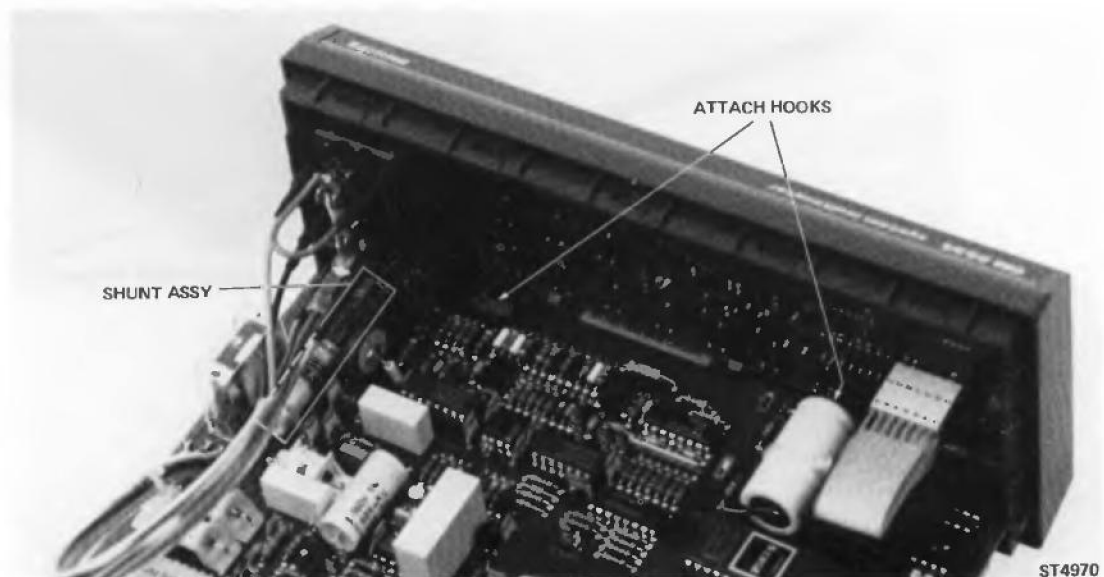

Figure 4.3

5. CHECKING AND ADJUSTING

5.1 GENERAL INFORMATION

The following information provides the complete checking and adjusting procedures. As various control functions are interdependent, a certain order of adjustment is necessary. The procedure is, therefore, presented in a sequence which is best suited to this order, cross-reference being made to any circuit which may affect a particular adjustment. Before any check or adjustment, the instrument must attain its normal operating temperature.

- Warming-up time under average conditions is 30 minutes.
- Where possible, instrument performance should be checked before any adjustment is made.
- All limits and tolerances given in this Section are calibration guides, and should not be interpreted as instrument specifications. The latter are published in the operating manual of this instrument.
- Tolerances given are for the instrument under test and do not include test equipment error.
- All controls which are mentioned without item numbers are located on the outside of the instrument.

5.2 CALIBRATION ADJUSTMENTS

The calibration adjustment procedure consists of two parts:

- Part A, to be used when components in the reference voltage circuit or the ADC circuit are replaced.
- Part B, to be used in all other cases.

PART A, adjustment of reference voltages and ADC

REFERENCE VOLTAGE ADJUSTMENT

If components in the reference voltage circuit are replaced, the reference voltage must be adjusted. Proceed as follows:

- Replace the wires 1 to 6 next to the resistors R1453, R1554, R1455, R1458, R1459 and R1460 if cut.
- Measure the voltage U_{ref} between points P and N (Fig. 6.5, bottom right hand corner) with an accuracy better than 0.1 %.
- Depending on the measured U_{ref} , the wires indicated in the table below with an asterisk (*) must be cut.

$U_{ref} >$	1	2	3	4	5	6
10.00	-	-	-	*	*	*
10.20	-	-	*	*	*	-
10.40	-	*	-	*	-	*
10.55	-	*	*	*	-	-
10.70	*	-	-	-	*	*
10.85	*	-	*	-	*	*
11.00	*	*	-	-	-	*
11.15	*	*	*	-	-	-

- Measure again the voltage between point P and N. If the voltage is lower than 10.00 volt replace the wires again and choose a value in the table which belongs to a lower value of U_{ref} .

ADC ADJUSTMENT

If components in the ADC circuit are replaced, or when the instrument must be set to another mains voltage frequency (see chapter 7), the dead band zero must be adjusted.

Proceed as follows:

- Set the instrument in function Vdc, range 3 V and speed 2.
- Supply alternating a voltage of +0.3 mV and -0.3 mV to the input
- Replace R1424 with a resistance box (5 kOhm up to 20 kOhm, steps according to the E96 resistance series). Adjust the resistance value until the difference between the displayed values for an input voltage of +0,3 mV and -0,3 mV is 60 counts \pm 1 count. Only the difference between the indications is important!
- Replace the resistance box with a resistor (MR25, E96, 1%) of the found value

example: +0.3 mV shows 0.00020 V difference = 60 counts
 -0.3 mV shows -0.00040 V

PART B, CALIBRATION ADJUSTMENT

PROCEDURE (See figure 5.1)

- Via the CAL switch (pencil operation) the CALIBRATION ENABLE mode is entered. While pressing the CAL switch, the RESET switch must be pressed. Release the RESET switch before releasing the CAL switch. In the CALIBRATION ENABLE mode the instrument is normally measuring.
- Press the CHECK key (PM2535 SHIFT CHECK) to start CALIBRATING
- Select the FUNCTION and RANGE to be calibrated with the FUNCTION and UP/DOWN keys respectively
- supply the required INPUT SIGNAL (see tables on page 5-5 to 5-9) to the input terminals
 The accuracy of the input signal, mentioned in the table part B is 5 times better than the 90 days accuracy of the meter.
- press SINGLE TRIGGER to calibrate.
 If the calibration is successful, the meter responds with a r (ready) at the end of the displayed value.
 If the supplied signal is not correct (out of range), or the range cannot be calibrated the meter responds with FAIL.
- Repeat this procedure for all functions and ranges to be calibrated.

By pressing the END (SHIFT CHECK for the PM2535) key, the meter leaves the CALIBRATION MODE, but stays in the CALIBRATION ENABLE mode. After RESET or POWER ON the CALIBRATION ENABLE mode is left.

Flow chart of the CALIBRATION ADJUSTMENT procedure:

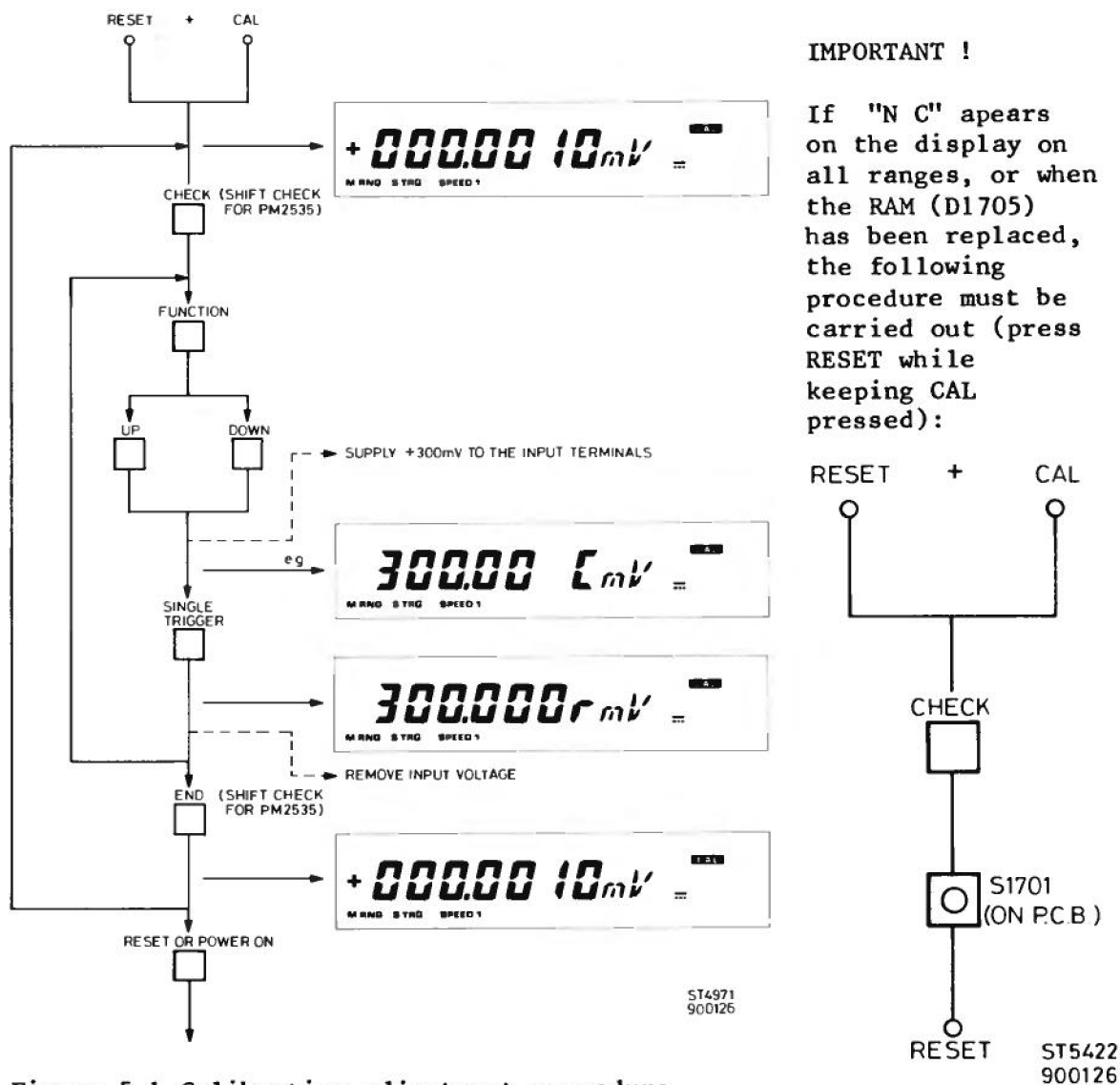

Figure 5.1 Calibration adjustment procedure

RECOMMENDED CALIBRATION EQUIPMENT:

- * Fluke 5700 calibrator
- * Valhalla 2724A Programmable resistance standard for the resistance ranges up to and including 3 MOhm; not for the ranges 30 and 300 MOhm !
- * Resistance box 8122 240 29971 for the 30 MOhm and 300 MOHM ranges. The box, providing a 30 MOhm and 300 MOhm resistance with the required accuracy can be ordered at the T&M Supply Centre Almelo in the Netherlands.

5.3 ADJUSTING THE PM2534/PM2535 USING A CONTROLLER

The calibration mode can be called via the IEC/IEEE-bus. To use this feature, a program string must be sent to the PM2534/PM2535. First the calibration enable mode must be entered. (Press the CAL and RESET switch and release the RESET switch before releasing the CAL switch).

Via the command CAL ON the calibration mode is enabled.

To calibrate a function with a range, select via the commands described in the operating manual, the function and range. The calibration can be started by sending a trigger command "X1" or "GET". After the calibration is finished the next function/range can be selected. The calibration mode is left by sending CAL OFF to the instrument. By this the calibration enable mode is entered again.

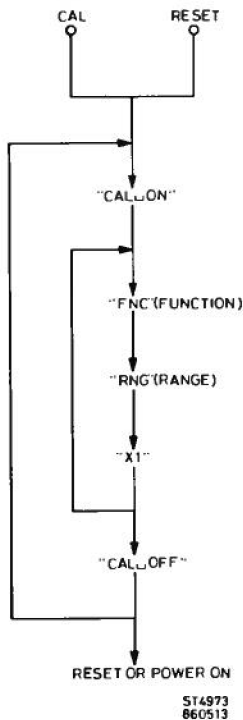

Figure 5.3 Flow-chart

Example with P2000C controller (cal enable mode already entered!)

```

10 IEC INIT
20 IEC PRINT #22, "CAL ON"      : cal-mode enabled
30 IEC PRINT #22, "FNC VDC"    : function volt DC
40 IEC PRINT #22, "RNG 30"     : range 30 volt
50 IEC PRINT #22, "X1"         : trigger
60 IEC PRINT #22, "CAL OFF"    : cal enable mode entered
70 IEC END
  
```

CALIBRATION TABLES

No	Adjustment	Preparation	Input signal	Display before calibration	Press	Display after calibration (displays first -----) Values ± 1 count	Remarks
1	Vdc 300 mV zero	Set instrument in: V=, 300mV	Short-circuit the V and 0-socket	300.00 C mV=	Single Trigger	+000.000r mV=	
	+300 mV			300.00 C mV=	Single Trigger	+300.000r mV=	
	-300 mV			300.00 C mV=	Single Trigger	-300.000r mV=	
2	Vdc 3 V zero	Set instrument in: V=, 3 V	Short-circuit the V and 0-socket	3.0000 C V=	Single Trigger	+0.00000r V=	
	+3 V			3.0000 C V=	Single Trigger	+3.00000r V=	
	-3 V			3.0000 C V=	Single Trigger	-3.00000r V=	
3	Vdc 30 V zero	Set instrument in: V=, 30 V	Short-circuit the V and 0-socket	30.000 C V=	Single Trigger	+0.00000r V=	
	+30 V			30.000 C V=	Single Trigger	+30.0000r V=	
	-30 V			30.000 C V=	Single Trigger	-30.0000r V=	
4	Vdc 300 V zero	Set instrument in: V=, 300 V	Short-circuit the V and 0-socket	300.00 C V=	Single Trigger	+000.000r V=	After the 300 V calibration you must wait at least 1 minute before continuing with another calibration!
	+300 V			300.00 C V=	Single Trigger	+300.000r V=	
	-300 V			300.00 C V=	Single Trigger	-300.000r V=	

CALIBRATION TABLES (CONTINUED)

No	Adjustment	Preparation	Input signal	Display before calibration	Press	Display after calibration (displays first -----) Values ± 1 count	Remarks
5	Vac 300 mV 300 mV 400 Hz	Set instrument in: V ⁻ , 300mV	300 mV $\pm 0.06\%$ 400 Hz	300.00 C mV ⁻	Single Trigger	300.00 r mV ⁻	
6	Vac 3 V 3 V 400 Hz	Set instrument in: V ⁻ , 3 V	3 V $\pm 0.06\%$ 400 Hz	3.0000 C V ⁻	Single Trigger	3.0000 r V ⁻	
7	Vac 30 V 30 V 400 Hz	Set instrument in: V ⁻ , 30 V	30 V $\pm 0.06\%$ 400 Hz	30.000 C V ⁻	Single Trigger	30.000 r V ⁻	
8	Vac 300 V 300 V 400 Hz	Set instrument in: V ⁻ , 300 V	300 V $\pm 0.06\%$ 400 Hz	300.00 C V ⁻	Single Trigger	300.00 r V ⁻	After the 300 V calibration you must wait at least 1 minute before continuing with the next calibration!
9	Ohm 2-wire pre cal zero precal open input precal 30 M Ω	Set instrument in: Ω -2w, autoranging	Short-circuit the V Ω and 0-socket open input 30 M Ω $\pm 0.02\%$	00.00 PC M Ω 0P.EN PC M Ω 30.000 PC M Ω	Single Trigger Single Trigger Single Trigger	0P.EN PC M Ω 30.000 PC M Ω 30.000 C M Ω	
10	Ohm 2-wire zero 3 k Ω	Set instrument in: Ω -2w, 3 k Ω	Short-circuit the V Ω and 0-socket 3 k Ω $\pm 0.004\%$	3.0000 C k Ω 3.0000 C k Ω	Single Trigger Single Trigger	0.00000r k Ω 3.00000r k Ω	

CALIBRATION TABLES (CONTINUED)

No	Adjustment	Preparation	Input signal	Display before calibration	Press	Display after calibration (displays first -----) Values ± 1 count	Remarks
11	Ohm 2-wire zero	Set instrument in: Ω -2w, 30 k Ω	Short-circuit the V Ω and 0-socket	30.000 C k Ω	Single Trigger	00.0000r k Ω	
	30 k Ω					30.0000r k Ω	
12	Ohm 2-wire zero	Set instrument in: Ω -2w, 300 k Ω	Short-circuit the V Ω and 0-socket	300.00 C k Ω	Single Trigger	000.000r k Ω	
	300 k Ω					300.000r k Ω	
13	Ohm 2-wire zero	Set instrument in: Ω -2w, 3 M Ω	Short-circuit the V Ω and 0-socket	3.0000 C M Ω	Single Trigger	0.00000r M Ω	
	3 M Ω					3.00000r M Ω	
14	Ohm 2-wire zero	Set instrument in: Ω -2w, 30 M Ω	Short-circuit the V Ω and 0-socket	30.000 C M Ω	Single Trigger	00.0000r M Ω	
	30 M Ω					30.0000r M Ω	
15	Ohm 2-wire zero	Set instrument in: Ω -2w, 300 M Ω	Short-circuit the V Ω and 0-socket	300.00 C M Ω	Single Trigger	000.00r M Ω	
	300 M Ω					300.00r M Ω	

CALIBRATION TABLES (CONTINUED)

No	Adjustment	Preparation	Input signal	Display before calibration	Press	Display after calibration (displays first -----) Values ± 1 count	Remarks
16	Ohm 4-wire zero	Set instrument in: Ω -4w, 3 k Ω	Short-circuit the Ω -4w input socket	3.0000 C k Ω	Single Trigger	0.00000r k Ω	
	3 k Ω			Single Trigger	3.00000r k Ω		
17	Ohm 4-wire zero	Set instrument in: Ω -4w, 30 k Ω	Short-circuit the Ω -4w input socket	30.000 C k Ω	Single Trigger	00.0000r k Ω	
	30 k Ω			Single Trigger	30.0000r k Ω		
18	Ohm 4-wire zero	Set instrument in: Ω -4w, 300 k Ω	Short-circuit the Ω -4w input socket	300.00 C k Ω	Single Trigger	000.000r k Ω	
	300 k Ω			Single Trigger	300.000r k Ω		
19	Ohm 4-wire zero	Set instrument in: Ω -4w, 3 M Ω	Short-circuit the Ω -4w input socket	3.0000 C M Ω	Single Trigger	0.00000r M Ω	
	3 M Ω			Single Trigger	3.00000r M Ω		
20	Adc 30 mA zero	Set instrument in: A, 30 mA	open input	30.000 C mA=	Single Trigger	+00.0000r mA=	
	+30 mA			Single Trigger	+30.0000r mA=		
	-30 mA			Single Trigger	-30.0000r mA=		

CALIBRATION TABLES (CONTINUED)

No	Adjustment	Preparation	Input signal	Display before calibration	Press	Display after calibration (displays first -----) Values ± 1 count	Remarks
21	Adc 3 A	Set instrument in: A~, 3 A	open input	3.0000 C A =	Single Trigger	+0.0000r A~	
	zero						
	+2 A						
	-2 A						
22	Asc 30 mA	Set instrument in: A~, 30 mA	30 mA $\pm 0.06\%$ 400 Hz	30.000 C mA~	Single Trigger	30.000r mA~	
	30 mA 400 Hz						
23	Asc 3 A	Set instrument in: A~, 3 A	2 A $\pm 0.07\%$ 400 Hz	3.0000 C A~	Single Trigger	2.0000r A~	

6. CORRECTIVE MAINTENANCE

6.1 SPECIAL PARTS

In addition to the standard electronic components, some special components are used:

- Components, manufactured or selected by Philips to meet specific performance requirements.
- Components which are important for the safety of the instrument.

ATTENTION: Both type of components may only be replaced by components obtained through your local Philips organisation or representative. These components have been marked in the Parts List by a *.

6.2 REPLACING PARTS

NOTE: SWITCH OFF MAINS BEFORE REMOVING PARTS.

6.2.1 Parts on the PCB

- Dismantle PM2534 (refer to section 4.1)
- Remove screening

6.2.2 LX- display, window and interconnection rubber

- Dismantle PM2534 (refer to section 4.1)
- Remove screening (refer to section 4.2)
- Remove front assembly (refer to section 4.4)
- Bend out the six hooks and lift the PCB out of the front assembly (figure 6.1)
- Push the attach hooks out of the holes at the component side of the PCB and lift the LCD display from the PCB (see figure 6.2).

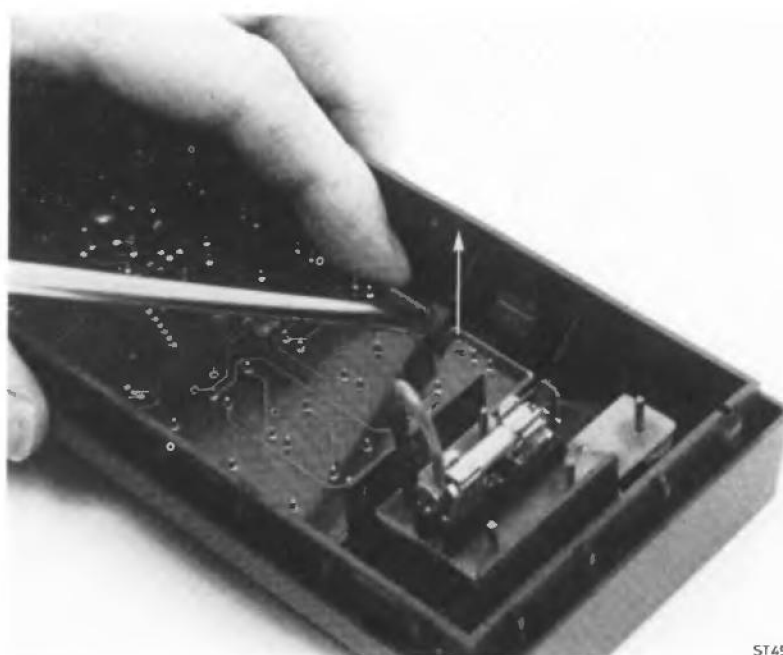

ST4974

Figure 6.1

The assembly of the display consists of four main parts (figure 6.2). All parts can be replaced separately.

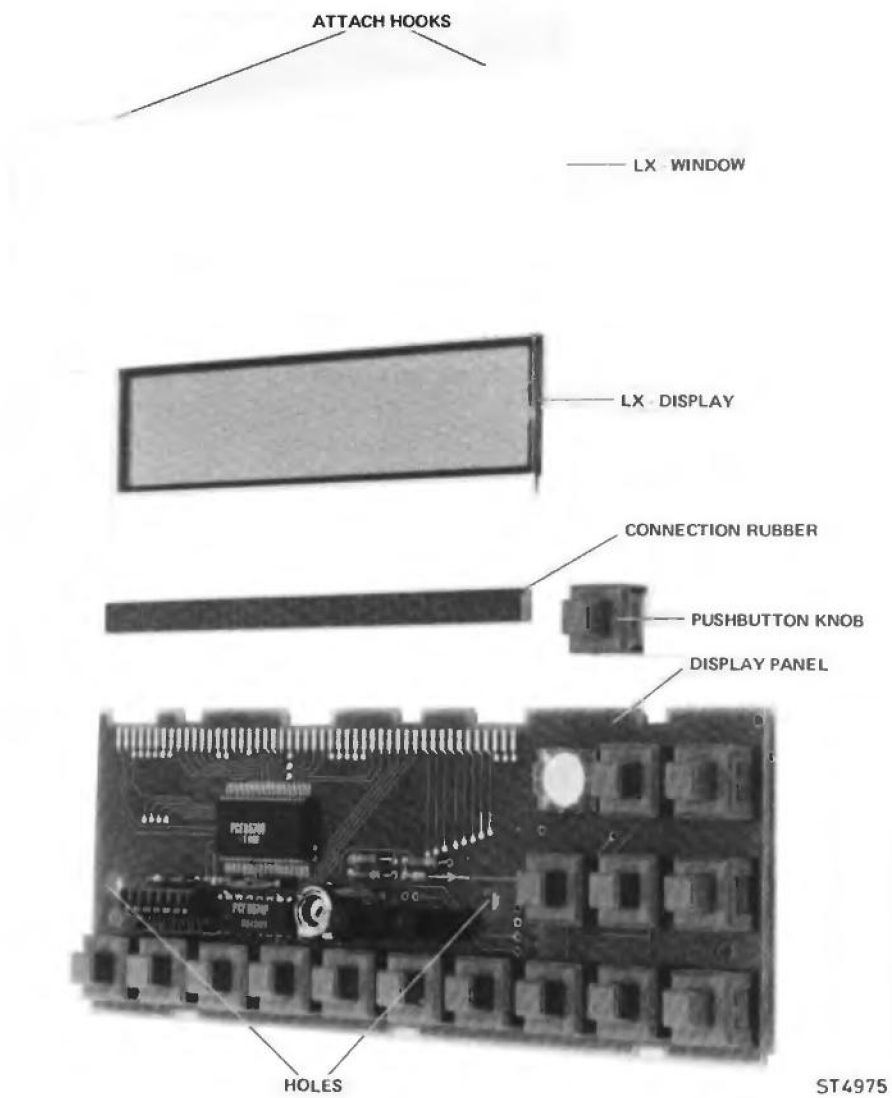
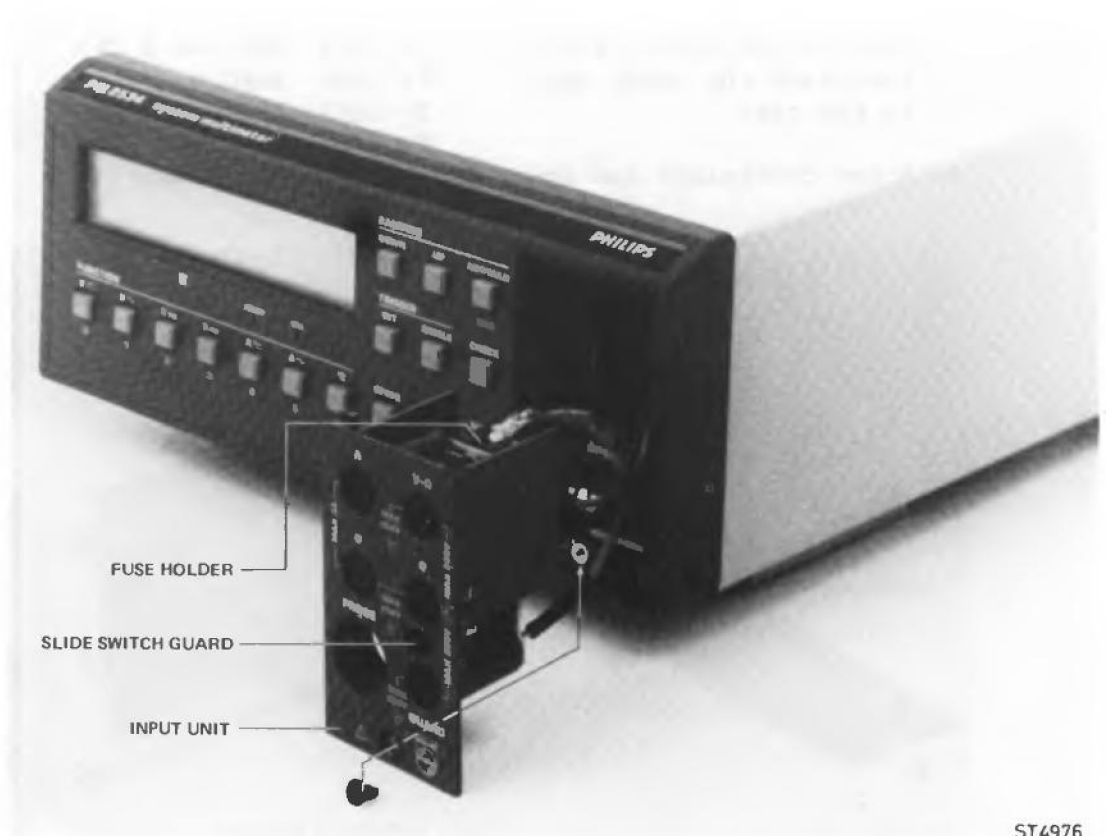

Figure 6.2

6.2.3 Input unit

- Dismantle the PM2534 (refer to section 4.1).
- Remove the screening (refer to section 4.2).
- Remove the fixing screw (figure 6.3).
- Pull out the input from the front assembly.
- Remove the wires from the input unit.
- Remove fixing screw in the fuseholder.
- Desolder the two wires of the switch.
- Lift-up PCB.
- Take care of the contact springs (ZERO and GUARD).
- Demount switch by using a pair of tweezers (be careful not to break the plastic mounting pins).



ST4976

Figure 6.3

6.2.4 Interchanging input unit (figure 6.4)

- It is possible to mount the input unit at the rear, often used in system configuration.

To do this proceed as follows:

- Dismantle PM2534
 - Remove screening
 - Remove fixing screws (front and rear) from the input unit front and the coverplate (rear)
 - Pull the input unit out of the front assembly
 - Remove the wires from the input unit
 - Remove coverplate at the rear
 - Place coverplate in front assembly
- | | | |
|----------------------------|---------|------------------|
| | Tp 1010 | RED = V Ω |
| - Connect the input cables | Tp 1009 | BLACK = 0 (V) |
| and place the input unit | Tp 1006 | BLEU = guard |
| in the rear | Tp 1007 | BROWN = A |
| | Tp 1008 | GREY = 0 (A) |
- Screw coverplate and input unit to the instrument

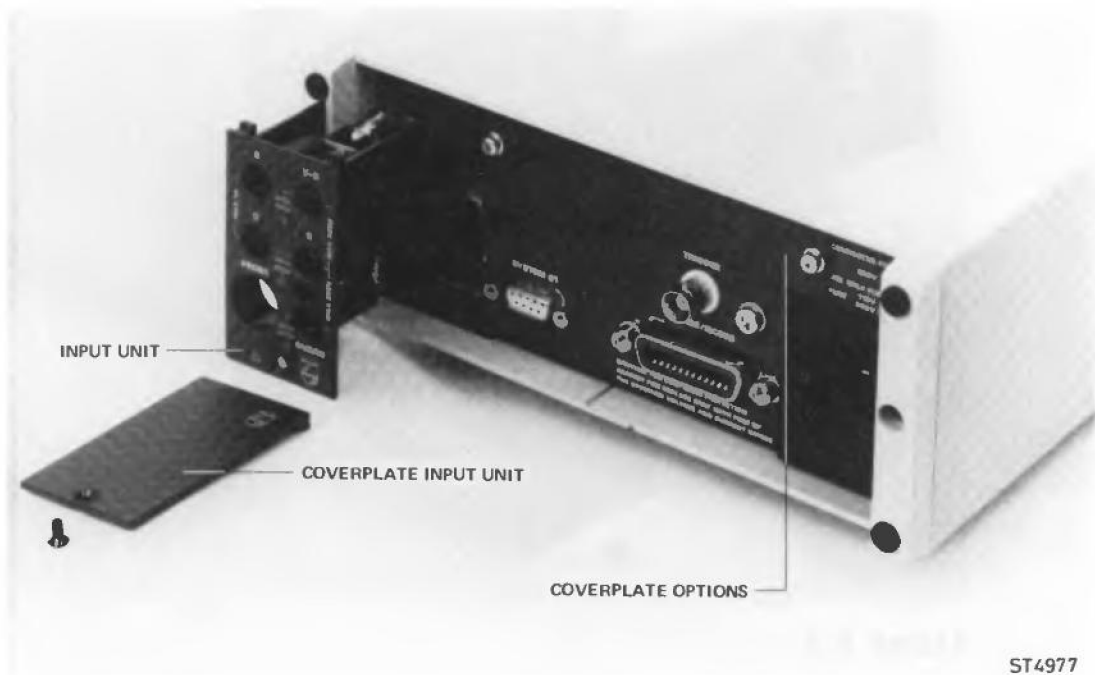

Figure 6.4

6.2.5 Fuses

Change fuse on the input unit

- Remove fixing screw in the input unit
- Pull the input unit out of the front assembly
- Replace fuse F1102 3,15A Fast blow

Change fuse F1901 on the motherboard (SYST 21)

- Dismantle PM2534
- Replace fuse F1901 200 mA Slow blow

6.3 TROUBLESHOOTING

The troubleshooting can be subdivided into two parts.

A: NORMAL MEASUREMENTS

For measurements with a multimeter and oscilloscope, the testpoints on the printed circuit board can be used.

This part provides a diagram with testpoint locations (figure 6.5), and an overview of wave forms and voltages on these testpoints. The testpoint numbers correspond with the those in the circuit diagrams (section 9).

Built-in tests are provided for the RAM, ROM and display (page 6-12)

A switching table, indicating the status of switching FETS and relays is given on page 6-13.

B: REPAIR BY SIGNATURE ANALYSIS USING A TESTROM.

Repair can be done with the aid of a testrom (ordering code 5322 694 54039). In this testrom, tests are implemented for signature analysis, ADC and display testing.

If repair has to be carried out, the following points should be taken in to account in order not to damage the instrument.

- Take care to avoid short-circuiting with measuring clips
- Use a miniature soldering iron (35 W max.)
- Use an acid-free solder
- After repair, the instrument should be calibrated (section 5)

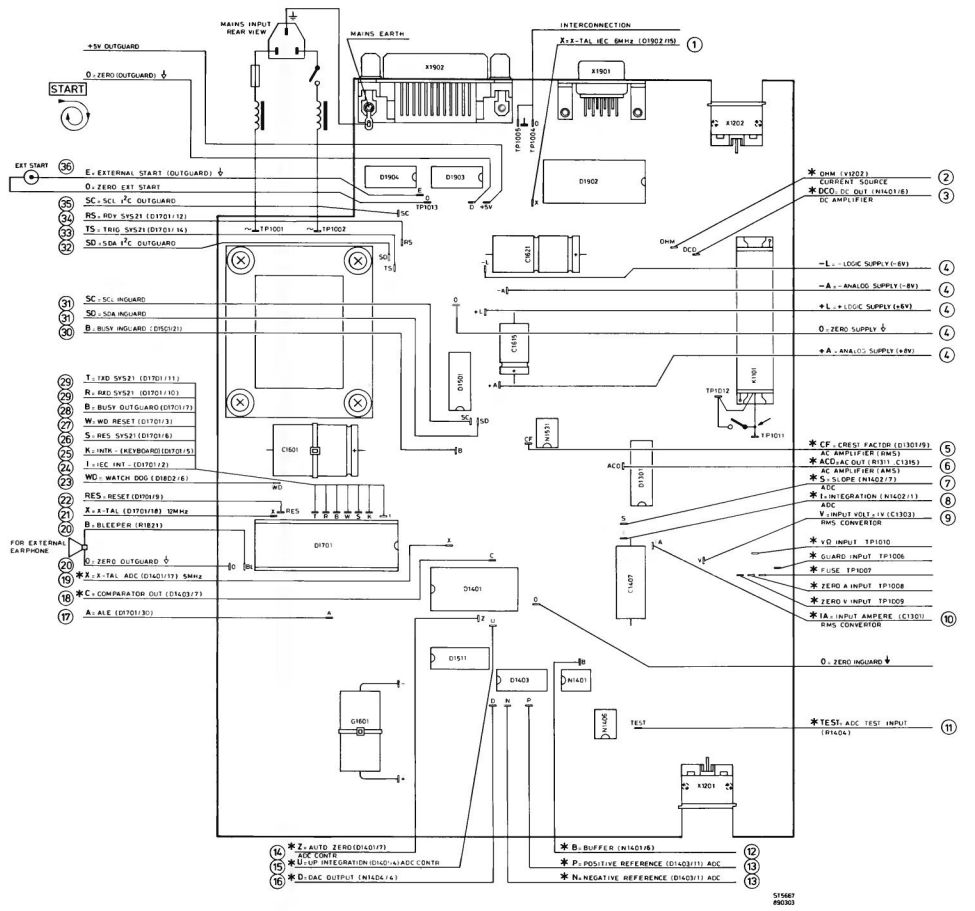

Figure 6.5 TEST PIN LOCATION

PART A

SIGNALS ON TESTPINS (refer to figure 6.5)





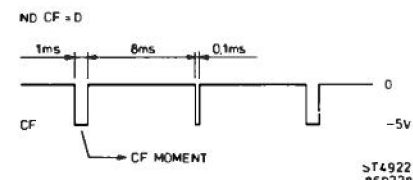
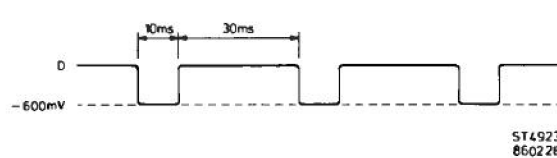

* = INGUARD SIGNALS WITH RESPECT TO ZERO INGUARD

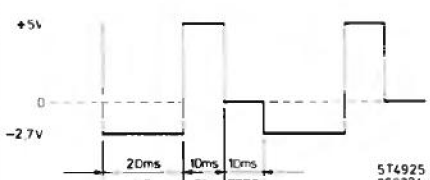
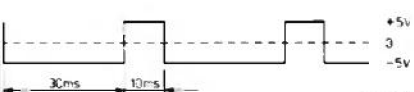
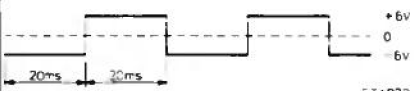
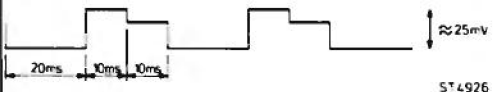

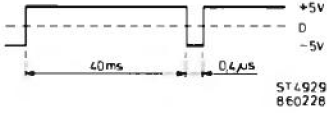
(NO) = OUTGUARD SIGNALS WITH RESPECT TO ZERO OUTGUARD

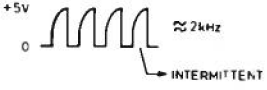
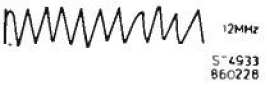
Remark: Take care with earthing in the d.c. functions

Testpin Figure	SIGNAL NAME (BEGINS WITH START)	PICTURE
① 9.4	X - TAL IEC 6 MHz (D1902/15)	
② 9.3	* OHM = Current source (V1202)	DC voltage $\approx -1,5$ V lk input <div style="margin-left: 150px;">↙ dependent on current</div>
③ 9.3	* DCO = DCout amplifier (N1101/6)	DC voltage + input = -V - input = +V range end = 3 V clamp = 5 V
④ 9.1	-L = -Logic supply +L = +Logic supply -A = -Analog supply +A = +Analog supply 0 = Zero supply	-6 V +6 V -8 V +8 V ↓
⑤ 9.3	* CF = Crest factor AC amplifier AC voltage in ≈ 8 V	
⑥ 9.3	* ACO = AC out a.c. amplifier (R1311/C1315)	DC voltage 0 → -V Clamp = -3 V
⑦ 9.3	* S = slope ADC (N1402/7)	Input = +2,7 V, speed 2  At - input, the signal is reversed

<p>⑧ 9.3</p>	<p>* I = Integration ADC (N1402/1)</p>	<p>Input +2,7 V, speed 2</p>  <p>5T4924 860228</p> <p>At - input, the signal is reversed</p>
<p>⑨ 9.3</p>	<p>* V = Input volt rms converter (C1303)</p>	<p>Follows AC input voltage to rms converter</p>
<p>⑩ 9.3</p>	<p>* IA = Input ampère rms convertor (C1301)</p>	<p>AC voltage from shunt to rms convertor</p>
<p>⑪ 9.3</p>	<p>* TEST = ADC test input (A1409/R1404)</p>	<p>To set a DC voltage in ADC test mode (to be followed)</p>
<p>⑫ 9.3</p>	<p>* B = output Buffer (N1401/6)</p>	<p>Input +2,7 V, speed 2</p>  <p>5T4925 860324</p> <p>UP = input connected DN = + ref connected ZERO = zero connected</p>
<p>⑬ 9.3</p>	<p>* P = Positive + reference (N1403/11) * N = Negative - reference (N1403/1)</p>	<p>+5 V -5 V</p>
<p>⑭ 9.3</p>	<p>* Z = Auto zero (D1401/7) ADC control</p>	 <p>5T4928 860228</p>
<p>⑮ 9.3</p>	<p>* U = Up integration (D1401/4) ADC control</p>	<p>Input +2,7 V, speed 2</p>  <p>5T4927 860228</p>
<p>⑯ 9.3</p>	<p>* D = Dac output (N1404/4)</p>	<p>Input +2,7 V, speed 2</p>  <p>5T4926 860228</p>

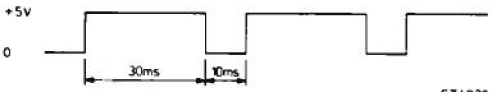
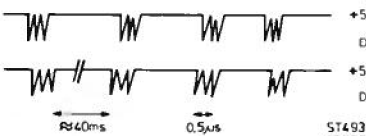
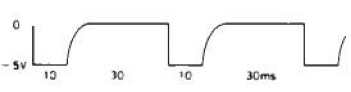
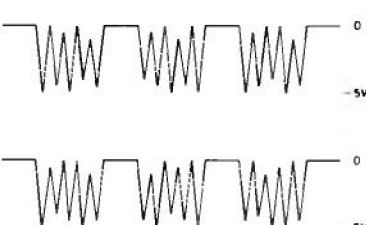
<p>①7 9.4</p>	<p>A = ALE (D1701/30)</p>	<p>Input +2,7 V, speed 2</p>  <p>ST4931 860228</p>
<p>①8 9.3</p>	<p>* C = Comparator output</p>	<p>Input +2,7 V, speed 2</p>  <p>ST4929 860228</p>
<p>①9 9.3</p>	<p>* X = X-TAL ADC 5 MHz (D1401/7)</p>	 <p>ST4930 860228</p>
<p>②0 9.4</p>	<p>B = Bleeper 0 = 0 bleeper</p>	 <p>ST4932 860228</p>
<p>②1 9.4</p>	<p>X = X-TAL up (D1701/18) 12 MHz</p>	 <p>ST4933 860228</p>
<p>②2 9.4</p>	<p>RES = Reset (D1701/9)</p>	 <p>ST4934 860228</p>
<p>②3 9.4</p>	<p>WD = Watchdog (D1802/6)</p>	 <p>ST4939 860228</p>
<p>②4 9.4</p>	<p>I = IEC interrupt (IEC INT-) (D1701/2)</p>	<p>Only when bus instr. is connected</p>
<p>②5 9.4</p>	<p>K = Interrupt from keyboard (D1701/5) (INTK-)</p>	 <p>ST4938 860228</p>
<p>②6 9.4</p>	<p>S = Reset sys 21 (D1701/6)</p>	<p>Logic 1 (+5 V)</p>
<p>②7 9.4</p>	<p>W = WD Reset (D1701/3) (watch dog)</p>	 <p>ST4937 860228</p>

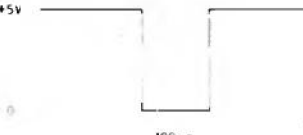
<p>②⑧ 9.4</p>	<p>B = Busy outguard (D1701/7)</p>	<p>Input +2,7 V, speed 2</p>  <p>ST4936 860228</p>
<p>②⑨ 9.4</p>	<p>T = transmit sys 21 (D1701/11) R = receive sys 21 (D1701/10)</p>	 <p>ST4935 860228</p>
<p>③⑩ 9.3</p>	<p>B = Busy inguard</p>	 <p>REFER TO BUSY OUTGUARD</p> <p>ST4943 860-79</p>
<p>③① 9.3</p>	<p>SC = SCL I²C inguard SD = SDA I²C inguard</p>	 <p>ST4942 860429</p>
<p>③② 9.4</p>	<p>SD = SDA I²C outguard</p>	 <p>ST4940 860228</p>
<p>③③ 9.4</p>	<p>TS = Trigger sys 21 (D1701/14)</p>	<p>Logic 1</p>
<p>③④ 9.4</p>	<p>RS = Ready sys 21 (D1701/12)</p>	<p>Logic 1</p>
<p>③⑤ 9.4</p>	<p>SC = SCL I²C outguard</p>	 <p>ST4941 860429</p>
<p>③⑥ 9.4</p>	<p>E = External Start (Outguard) 0 = Zero</p>	<p>Refer to specification Signal "EXINT-"</p>  <p>ST5054 860429</p>

Built-in tests

The ROM, RAM and display of the PM2534 and PM2535 can be tested by the standard software of the instrument. These tests only indicate a failure (ERROR on display); they do not locate the faulty component.

To activate the PM2534 test proceed as follows:

- Push 4 times the "CHECK" switch. Display ==> tEST 0
- Push the "1" switch. Display ==> tEST 1
- Push the "END" switch. START of internal tests

To activate the PM2535 test proceed as follows:

- Push the "SHIFT" switch.
- Push the "CHECK" switch.
- Push 3 times the "ENTER" switch. Display ==> tEST 0
- Push the "1" switch. Display ==> tEST 1
- Push the "ENTER" switch. START of internal tests

The flow chart below shows how to select the tests after the procedure described above has been carried out.

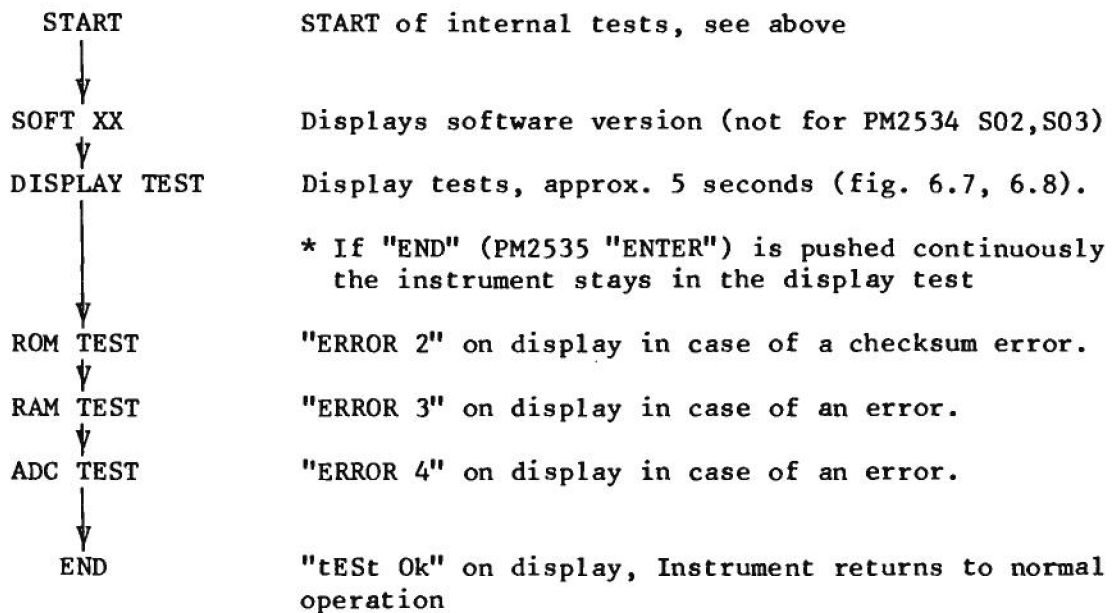
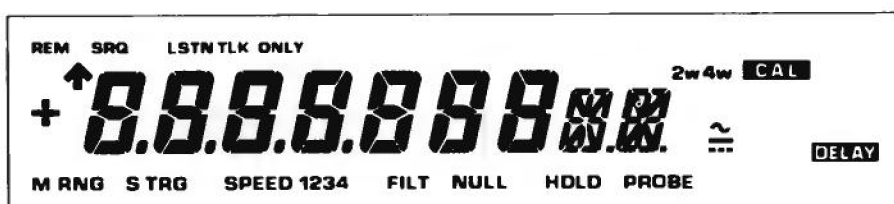

Figure 6.6 Built-in tests

In the display test of the PM2534, the following is displayed:



ST4979

Figure 6.7 PM2534 display in display test

In the display test of the PM2535, the following is displayed:



ST4980

Figure 6.8 PM2535 display in display test

Table of control signals for relays and FETs:

Function	Range	D1513					D1512						D1401			
		7 01	6 02	5 03	4 04	3 05	5 R1	6 R2	7 R3	10 R5	11 R6	12 R7	8 OA	9 OB	10 OC	11 OD
V dc	300 mV	0	0	0	1	0	0	0	0	0	0	0	*a	*b	0	1
	3 V	0	0	1	1	0	0	0	0	0	0	0	*a	*b	0	0
	30 V	0	0	0	0	0	1	0	0	0	0	0	*a	*b	0	1
	300 V	0	0	1	0	0	1	0	0	0	0	0	*a	*b	0	0
V ac	300 mV	0	1	0	0	0	0	0	0	0	0	x	0	0	1	0
	3 V	0	1	0	0	0	0	0	0	0	1	x	0	0	1	0
	30 V	0	1	0	0	0	0	0	0	1	0	x	0	0	1	0
	300 V	0	1	0	0	0	0	0	0	1	1	x	0	0	1	0
Ohm-2W	3 k	1	0	1	1	0	0	0	0	0	0	1	0	0	0	0
	30 k	1	0	1	1	0	0	0	0	1	0	1	0	0	0	0
	300 k	1	0	1	1	0	0	0	0	0	1	0	0	0	0	0
	3 M	1	0	1	1	0	0	0	0	1	1	0	0	0	0	0
	30 M	1	0	1	1	0	0	0	0	1	0	0	0	0	0	0
	300 M	1	0	1	1	0	0	0	0	1	0	0	0	0	0	0
Ohm-4W	3 k	0	0	0	0	0	0	0	1	0	0	1	1	1	0	0
	30 k	0	0	0	0	0	0	0	1	1	0	1	1	1	0	0
	300 k	0	0	0	0	0	0	0	1	0	1	0	1	1	0	0
	3 M	0	0	0	0	0	0	0	1	1	1	0	1	1	0	0
A dc	30 mA	0	0	0	0	1	0	1	0	0	0	0	*a	*b	0	1
	3 A	0	0	0	0	0	0	1	0	0	0	0	*a	*b	0	1
A ac	30 mA	0	0	0	0	1	0	0	0	0	0	x	0	0	1	0
	3 A	0	0	0	0	0	0	0	0	0	0	x	0	0	1	0
°C	850 °C	0	0	0	0	0	0	0	1	0	0	1	1	1	0	0

x depends on FILTER ON/OFF

filter on : x = 1
filter off: x = 0

*a and *b depend on MEASURING SPEED:

speed 1+2 : *a = 0 ; *b = 1
speed 3+4 : *a = 1 ; *b = 0

1 = 0 Volt (+6 Volt for D1401); relay contact closed, FET conducting
0 = -6 Volt; relay contact open, FET not conducting

PART B Tests with Signature Analysis and Testrom

Brief description of Signature Analysis.

1. General

For repair by signature analysis a testrom has been developed. This testrom enables the user to test the digital part of the PM2534 by means of Signature Analysis.

Troubleshooting is now possible to component level by a circuit under test, by comparing the actual signature with the correct one.

In total there are 10 tests. In the testrom, 9 tests have been implemented and one test is made with the free-run facility of the PM2534.

2. Why use a Signature Analyser?

When using a microcomputer, the bus structure is very complex. In case of a failure, it cannot be analysed with an oscilloscope or voltmeter. The signature analyser can be used now. Finding faults in a difficult bus system can best be done by opening the feedback part, and then it will become easy.

Brief description of the tests.

Free-run test:

With this test it is possible to measure signatures on the address latches and the databus of the processor. This is necessary to check if the data can be taken from the testrom.

Test 0 (digital part and galvanic separation).

This test checks the I/O parts and the galvanic separation between inguard and outguard.

Test 1 (I²C bus and switch decoding)

In this test the I²C lines are checked. Also the decoding of the switches on the display pcb are tested.

Test 2 - Test 4 (ADC)

These tests are for testing the ADC. A voltage (depends on which test) on the input of the ADC is present. In the ADC circuit the various voltages can be measured.





Test 5 - Test 9

With these tests the display is tested. A short-circuit between two segments, backplanes etc. can be seen on the display.

3. Free-run test

- Remove jumper S1702
- Signals with a * seem to be logic 0 or logic 1 but still show activity (blinking LED)
- Reference: logic 0 = 0000
logic 1 = 0003

Setting signature analyser

Setting	Edge/Mode	Connections	Test point	Signal name
start		start	D1701 pin 28	AD 15
stop		stop	D1701 pin 28	AD 15
clock		clock	D1701 pin 29	program store enable
ground		ground	0	0

NAME	LOCATION	
ADDRESS BUS	D1702	SIGNATURES
A 0	pin 6	UUUU
A 1	pin 9	FFFF
A 2	pin 12	8484
A 3	pin 5	P763
A 4	pin 2	1U5P
A 5	pin 15	0356
A 6	pin 16	4759
A 7	pin 19	6F9A
	D1701	
A 8	pin 21	7791
A 9	pin 22	6321
A 10	pin 23	37C5
A 11	pin 24	6U28
A 12	pin 25	4FCA
A 13	pin 26	4868
A 14	pin 27	94P1
A 15	pin 28	0002

For measuring signatures on the data bus the clock must be connected to ALE (D1701 pin 30). On the signature analyser the falling edge of the clock must be selected.

Setting	Edge mode	Connections	Testpoint	Signal name
clock		clock	A	ALE

SIGNATURES ON THE DATA BUS

DATABUS	D1701	SIGNATURES
D 0	pin 39	UUUU
D 1	pin 38	FFFF
D 2	pin 37	8484
D 3	pin 36	P763
D 4	pin 35	1U5P
D 5	pin 34	0356
D 6	pin 33	4759
D 7	pin 32	6F9A

If a PM2544 signature analyser is used, the following can also be measured.

Frequencies: { D1701 pin 18 XTAL/1 and 19 XTAL/2, 12 MHz
 { D1701 pin 29 $\overline{\text{PSEN}}$ and 30 ALE, 2 MHz

TEST EXT.START CIRCUIT

Time measurements

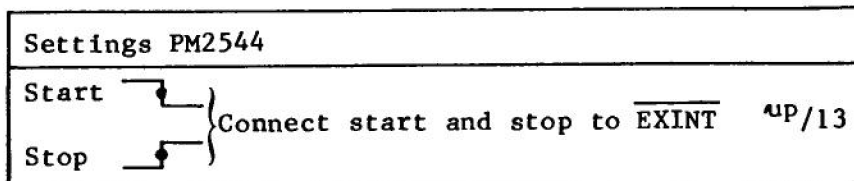

Short-circuit the EXT TRIG input to earth.
 The time measured must be between 40-150 us.

TEST WATCHDOG

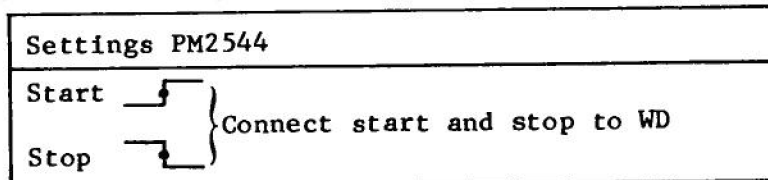



Short-circuit test pin W to earth.
 The time measured must be between 200-600 msec.

4. Test 0

- Switch off the POWER and remove the EPROM D1703
- Check your testrom type, it must be a 256 K type (27256); if it is a 64 K type (2764), refer to section 10.1 Modification 6.
- Place the TEST ROM in the socket of D1703.
- Connect the anode of V1703 (located near D1703) to test pin 0 (zero outguard, see figure 6.5 on page 6-7), to avoid a reset of the RAM
- Connect test pin -L (logic supply -6 V inguard) to the zero of the +5 V outguard supply (test pin 0, refer to figure 6.5 on page 6-7).
- Switch on the meter (the display shows tEst 0) and measure the signatures as given on the next pages.

- Signals with a * seem to be logic 0 or 1 but still show activity (blinking LED)
- Reference: logic 0 = 0000
logic 1 = 82CP

Setting signature analyser

Setting	Edge/Mode	Connections	Testpoint	Signal name
Start/stop		Start/stop	RS	RDY SYS
Clock		Clock	A	ALE
Qualifier		Qualifier	TS	TRI SYS
Ground		Ground	0	0

D1701 pin	SIGNATURE
1	82CP*
2	0000
3	FFAP
4	AU4A
5	PAOF
6	PPA8
7	0000
8	H9A5
9	0000
10	282P
11	4578
12	82CP*
13	3383
14	82CP*
15	0439
16	6573
17	8240
18	82CP
19	0000
20	0000
21	82CP
22	82CP
23	0000
29	82CP
31	0000
33	82CP
34	458A
35	C334
36	U6CP
37	39C2
38	72AH
39	6UPP
40	82CP

→ Signature on test pin SD
(inguard and outguard)

→ Signature on test pin SC
(inguard and outguard)

IC D1401		IC D1401	
Pin	Signature	Pin	Signature
1	CCAA	15	CCAA
4	0000	16	CCAA
5	0000	17	Unstable
6	0000	18	CCAA
7	CCAA	19	0000
8	7743	20	Unstable
9	C96F	21	0000
10	FAP1	22	CCAA
11	C631	23	CCAA
12	0000	24	CCAA

RES SYS 21 (27)

The next signatures must be measured on test pin S (outguard). If an IC, connected with the I²C bus, is receiving data, it sends back an acknowledge. If no acknowledge is received from that I²C, the signature changes.

All I²C integrated circuits ok, signature: 0462 (RES SYS 21 (27))





The following signatures can be measured on pin S if the devices mentioned in the table not sending acknowledge:

IC's not sending acknowledge	SIGNATURES
ALL IC's OK	0462
D1404	781H
D1511	067U
D1512	APC9
D1513	1H56
D1902	C8P9
D2101	PO2C
D2201	31C4

5. Test 1 (I²C devices)

- Select test 1 with S1701 (test 1 on display)
- Reference: logic 0 0000
 logic 1 CCAA
- The anode of V1703 must be connected to test pin 0.(zero outguard) to avoid reset of RAM
- Test pin -L (inguard) must be connected 0 (zero outguard)

Setting signature analyser

Setting	Edge/Mode	Connections	Testpoint	Signal name
Start/stop		Start/stop	RS	RDY SYS
Clock		Clock	A	ALE
Qualifier		Qualifier	TS	TRI SYS
Ground		Ground	0	0

IC D1511		IC D1512		IC D1513	
Pin	Signatures	Pin	Signatures	Pin	Signatures
1	0000	1	CCAA	1	0000
2	CCAA	2	0000	2	CCAA
3	CCAA	3	CCAA	3	8999
4	F7C7	4	P3C9	4	Unstable
5	2P1P	5	CA9A	5	4P43
6	A3C1	6	999F	6	9P08
7	133P	7	1CA0	7	FFPF
8	0000	8	0000		
9	5C47	9	6AHO		
10	2299	10	641F		
11	F6F1	11	1AA2		
12	5H93	12	74HC		
13	CCAA	13	0000		
16	CCAA	16	CCAA		

- Pushing a switch on the front will also give a different signature on PIN S (outguard).

PUSHBUTTON	SIGNATURE
0	92P4
1	A365
2	9HUF
3	6AU5
4	08PP
5	C479
6	F683
7	0P92
8	176U
9	PUC7
INT	H4F9
SINGLE	8595
CHECK	6817
DOWN	628U
UP	7UA7
AUT/MAN	485H

The following signatures can be measured on the I/O expander D2201 (display pcb).

IC D2201			
Pin	Signature	Pin	Signature
1	CAAA	9	0000
2	-	10	C607
3	-	11	1022
4	CAAA	12	2U3U
5	OAC2	13	3203
6	C1F7	14	CCAA
7	P8FH	15	0000
8	2656	16	0000

6. Test 2, 3 and 4 Description of the tests

Tests 2, Test 3 and Test 4 are in principle the same tests, they test the ADC with different voltages on the input.

Voltage on pin 3 of D1402 in TEST 2 = -3 V

Voltage on pin 3 of D1402 in TEST 3 = +0,6 V

Voltage on pin 3 of D1402 in TEST 4 = 0 V

- Test 2 signals

Test 2 can be selected with S1701 (Test 2 on display)

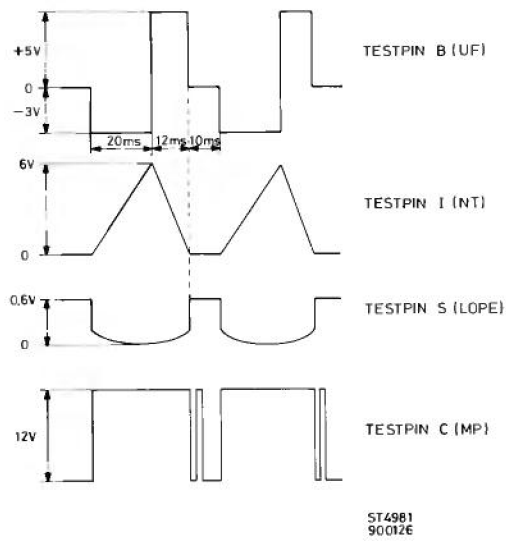

Figure 6.9 Test 2 signals

- Test 3 signals

Test 3 can be selected with S1701 (Test 3 on display)

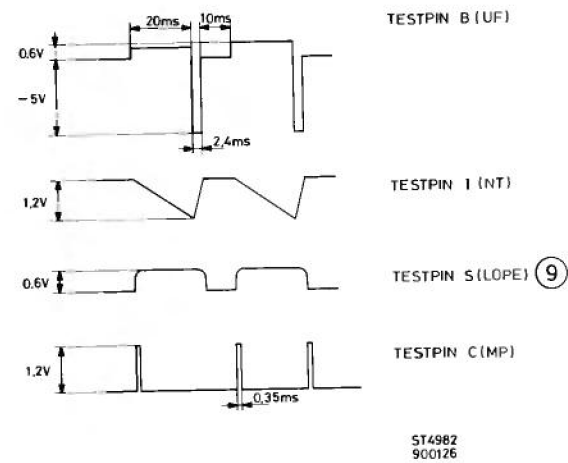
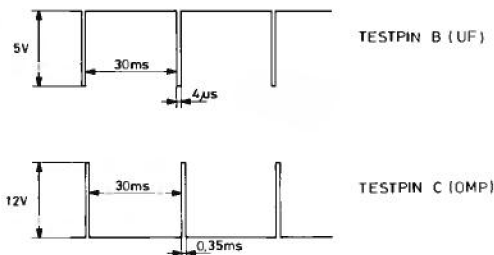

Figure 6.10 Test 3 signals

- Test 4 signals

Test 4 can be selected with S1701 (Test 4 on display)



ST4983
900126

Figure 6.11 Test 4 signals

7. Test 5-9

Test 5 - Test 9 are for testing the display (visual), they can be selected with S1701.

- Test 5

In test 5 all segments are on.

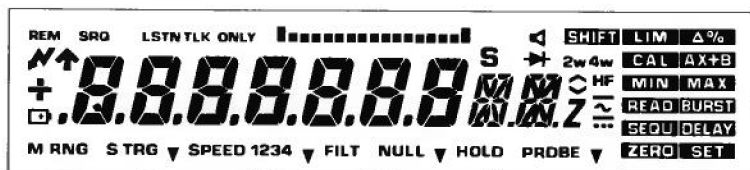

ST4962

Figure 6.12 Test 5 signals

Test 6

In this test all even segments (S_0, S_2, S_4 - etc.) are on.



ST4963

Figure 6.13 Test 6 signals

Test 7

In this test all odd segments (S_1, S_3, S_5 , etc.) are on.

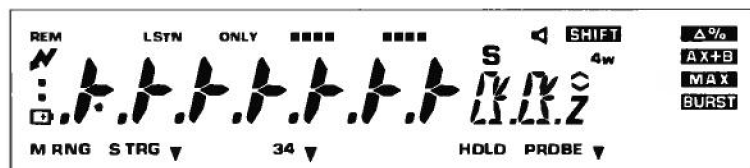

ST4964

Figure 6.14 Test 7 signals

Test 8

All segments from backplanes 1 and 3 are on.

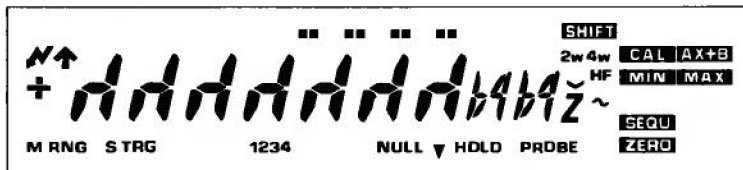

ST4965

Figure 6.15 Test 8 signals

Test 9

All segments from the backplanes 0 and 2 are on.

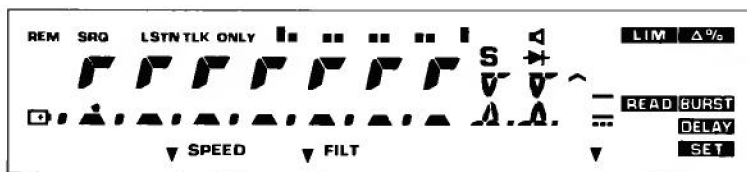

ST4966

Figure 6.16 Test 9 signals

7. SAFETY INSPECTION TESTS AFTER REPAIR AND MAINTENANCE IN THE PRIMARY CIRCUIT

7.1 GENERAL DIRECTIVES

- Take care that the creepage distance and clearances have not been reduced.
- Before soldering, the wires should be bent through the holes of solder tags, or wrapped around the tag in the form of an open U, or Wiring rigidity shall be maintained by cable clamps or cable lacing.
- Replace all insulating guards and plates.

7.2 SAFETY COMPONENTS

Components in the primary circuit may only be replaced by components selected by Philips, see also 8.

7.3 CHECKING THE PROTECTIVE EARTH CONNECTION

The correct connection and condition is checked by visual control and by measuring the resistance between the protective lead connection at the plug and the cabinet/frame. The resistance shall not be more than 0,5 Ohm. During measurements the mains cable should be removed. Resistance variations indicate a defect.

7.4 ADAPTATION TO THE LOCAL MAINS

For adaptation to the local mains the wiring positioned under the mains transformer must be altered.

Proceed as follows:

- Remove the cover
- Change the drawing as shown in figure 7.1 (230 V, 1 connection; 115 V, 2 connections).

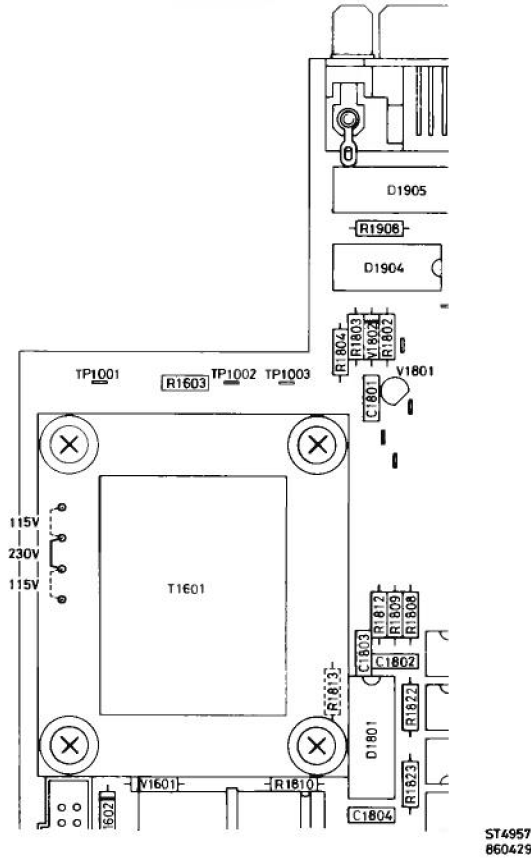

Figure 7.1 Adaption to the local mains

7.5 ADAPTATION TO THE LOCAL MAINS FREQUENCY

For adaptation to 60 Hz the 5 MHz X-tal (G1401) must be changed for a 6 MHz X-tal (codenr. 5322 242 74364). Also a new adjustment must be made for the ADC control (refer to Chapter 5 page 5.4 adjustment number 2).

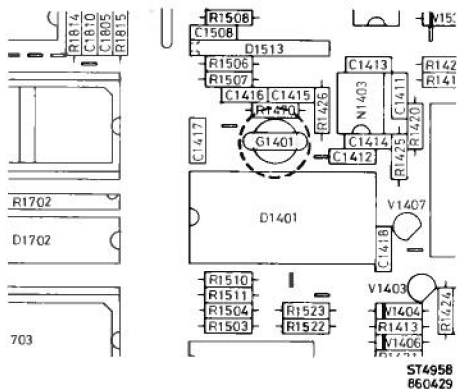

Figure 7.2

8. PARTS LIST

NOTE: if a component is marked *x (x is a number), you must refer to modification x, in Section 11, "MODIFICATIONS".

8.1 MECHANICAL PARTS

Description	Ordering no.	Figure
L.C.D.	5322 130 90279	6.2
Pushbutton knob all functions	5322 414 20031	6.2
Pushbutton knob SHIFT/ENTER (white)	5322 414 60146	
Window	5322 450 60633	6.2
Front assembly (PM2534)	5322 447 70087	
Front assembly (PM2535)	5322 447 90691	
Input unit	5322 694 54034	6.3
Contact spring (input)	4822 530 80158	
Fuseholder	5322 256 34079	6.3 and 8.1
Slide switch (guard)	5322 277 21046	6.3
Reed contact	5322 280 24126	8.1
Flat cable	5322 321 21307	8.1
Jumper	5322 263 60062	8.1
Foot (rear)	5322 462 10258	8.2
Footplug (rear)	5322 462 40109	8.2
Foot (bottom)	5322 462 10259	8.2
Footplug (bottom)	5322 462 44148	8.2
Lever (left)	5322 405 90307	8.2
Lever (right)	5322 405 90308	8.2
Handle	5322 498 50193	8.2
PCB guide	5322 290 60588	
Plastic connecting rail	5322 460 60398	4.1
Coverplate (input unit)	5322 460 60397	6.4
Coverplate (options)	5322 460 60399	6.4
Measuring pin black	5322 264 20045	
Measuring pin red	5322 264 20046	
Lead black	5322 321 20572	
Lead red	5322 321 20573	
Adapter red	5322 264 20051	
Adapter black	5322 264 20052	
Mains cable	5322 321 10388	
Fuse F 5x20 3,15 A	4822 253 20025	
Fuse T 5x20 63 mA	4822 253 30004	
Fuse T 5x20 125 mA	4822 253 30007	
Fuse T 5x20 200 mA	4822 253 30012	
Screw special M3x13	5322 502 13163	
Inter connection rubber	5322 267 50753	
8-p Din plug, male	5322 266 44031	
Mains input connector (fuse holder and mains switch included)	5322 265 30406	

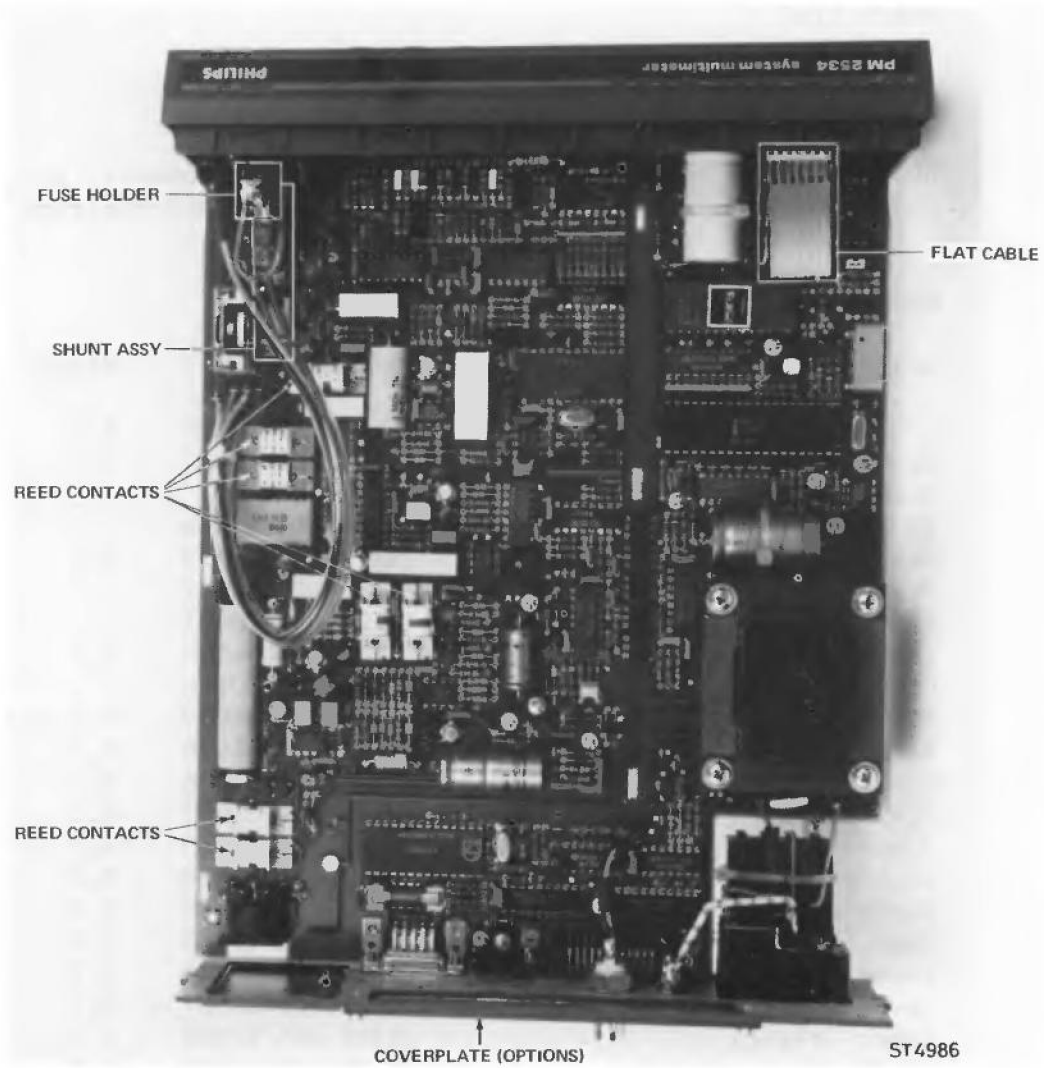

Figure 8.1

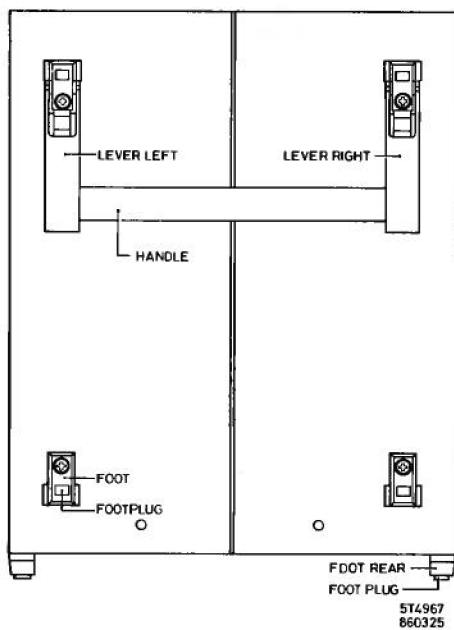

Figure 8.2

8.2 ELECTRICAL PARTS

8.2.1 Capacitors

posno.	description	ordering no.
C 1101	2% 100PF	5322 122 32655
C 1102	63V 10% 390NF	5322 121 42502
C 1103	63V 10% 390NF	5322 121 42502
C 1104	2% 18PF	4822 122 31061
C 1105	-20+80% 22NF	4822 122 30103
C 1106	-20+80% 22NF	4822 122 30103
C 1107	100V 10% 1UF	5322 121 40197
C 1201	630V 1% 1NF	4822 121 50591
C 1202	-20+80% 22NF	4822 122 30103
C 1203	-20+80% 22NF	4822 122 30103
C 1204	2% 33PF	5322 122 32072
C 1303	400V 10% 68NF	4822 121 42078
C 1304	2% 12PF	4822 122 31196
C 1305	2% 12PF	4822 122 31196
C 1306	0.25PF 0.68PF	4822 122 31215
C 1307	63V 1% 2150PF	5322 121 50985
C 1308	2% 330PF	5322 122 32704
C 1310	2% 100PF	4822 122 31316
C 1311	10V 20% 15UF	5322 124 14036
C 1312	-20+80% 22NF	4822 122 30103
C 1313	-20+80% 22NF	4822 122 30103
C 1314	63V 10% 150NF	4822 121 41854
C 1315	100V 10% 1.5UF	5322 121 40227
C 1316	63V 10% 100NF	5322 121 42386
C 1317	100V 10% 1UF	5322 121 40197
C 1401	-20+80% 22NF	4822 122 30103
C 1402	-20+80% 22NF	4822 122 30103
C 1403	-20+80% 22NF	4822 122 30103
C 1404	-20+80% 22NF	4822 122 30103
C 1405	-20+80% 22NF	4822 122 30103
C 1406	-20+80% 22NF	4822 122 30103
*3 C 1407	63V 1% 160NF	5322 121 54116
C 1408	63V 10% 220NF	5322 122 32255
C 1409	100V 10% 3.3UF	5322 121 40283
C 1410	-20+80% 22NF	4822 122 30103
C 1411	2% 220PF	5322 122 34047
C 1412	-20+80% 22NF	4822 122 30103
C 1413	-20+80% 22NF	4822 122 30103
C 1414	-20+80% 22NF	4822 122 30103
C 1415	2% 18PF	4822 122 31061
C 1416	2% 18PF	4822 122 31061
C 1417	-20+80% 22NF	4822 122 30103
C 1418	-20+80% 22NF	4822 122 30103
C 1433	50V 10% 22NF	5322 122 10356
C 1434	50V 10% 22NF	5322 122 10356
C 1451	50V 10% 22NF	5322 122 10356
C 1452	50V 10% 22NF	5322 122 10356
C 1454	50V 10% 22NF	5322 122 10356
C 1455	630V 1% 51.1PF	5322 121 50984
C 1456	2% 18PF	4822 122 31061
C 1457	2% 100PF	4822 122 31316
C 1458	50V 10% 22NF	5322 122 10356
C 1501	-20+80% 22NF	4822 122 30103
C 1502	-20+80% 22NF	4822 122 30103
C 1503	-20+20% 10UF	5322 124 21731
C 1504	-20+80% 22NF	4822 122 30103
C 1505	-20+80% 22NF	4822 122 30103
C 1506	50V 10% 22NF	5322 122 10356
C 1507	-20+80% 22NF	4822 122 30103
C 1508	-20+80% 22NF	4822 122 30103

posno.	description		ordering no.
C 1509	-20+80%	22NF	4822 122 30103
C 1510	-20+80%	22NF	4822 122 30103
C 1511	-20+80%	22NF	4822 122 30103
C 1512	-20+80%	22NF	4822 122 30103
*8 C 1513	-20+80%	22NF	4822 122 30103
C 1514	-20+80%	22NF	4822 122 30103
C 1515	-20+80%	22NF	4822 122 30103
C 1516	-20+80%	22NF	4822 122 30103
C 1531	-20+80%	22NF	4822 122 30103
C 1601	-20+20%	4700UF	5322 124 21504
C 1602	-20+20%	1UF	5322 124 41098
C 1603	-20+20%	10UF	5322 124 21731
C 1611	-20+20%	1UF	5322 124 41098
C 1612	-20+80%	22NF	4822 122 30103
C 1613	-20+20%	1UF	5322 124 41098
C 1614	-20+80%	22NF	4822 122 30103
C 1615	-10+50%	330UF	4822 124 20694
C 1616	-20+20%	10UF	5322 124 21731
C 1617	-20+80%	22NF	4822 122 30103
C 1618	-20+80%	22NF	4822 122 30103
C 1619	-20+20%	1UF	5322 124 41098
C 1620	-20+80%	22NF	4822 122 30103
C 1621	-20+20%	1500UF	4822 124 21505
C 1701	-20+20%	10UF	5322 124 21731
C 1702	2%	33PF	5322 122 32072
C 1703	2%	33PF	5322 122 32072
C 1704	-20+80%	22NF	4822 122 30103
C 1705	-20+80%	22NF	4822 122 30103
C 1706	-20+20%	10UF	5322 124 21731
C 1708	-20+80%	22NF	4822 122 30103
C 1801	-20+50%	10NF	4822 122 31414
C 1802	-20+80%	22NF	4822 122 30103
C 1803	-20+80%	22NF	4822 122 30103
C 1804	-20+80%	22NF	4822 122 30103
C 1805	-20+80%	22NF	4822 122 30103
C 1806	-20+80%	22NF	4822 122 30103
C 1807	-20+20%	10UF	5322 124 21731
C 1808	-20+20%	1UF	5322 124 41098
C 1809	-20+20%	10UF	5322 124 21731
C 1810	-20+80%	22NF	4822 122 30103
C 1901	-20+80%	22NF	4822 122 30103
*13 C 1902	2%	5P6	5322 122 32163
*13 C 1903	2%	5P6	5322 122 32163
C 1904	-20+80%	22NF	4822 122 30103
C 1905	-20+20%	10UF	5322 124 21731
C 1906	-20+80%	22NF	4822 122 30103
C 1907	-20+80%	22NF	4822 122 30103
C 1908	-20+80%	22NF	4822 122 30103
C 2101	10%	22NF	5322 122 10457
C 2102	-20+80%	22NF	4822 122 30103

8.2.2 Resistors

posno.	description		ordering no.
R 1101			5322 111 94044
R 1102	MR25	1% 100E	5322 116 55549
R 1103	VR68	5% 100K	5322 116 51722
R 1104	MR25	1% 6K19	5322 116 55426
R 1105	MR25	1% 10K	4822 116 51253
R 1106	MR25	1% 6K19	5322 116 55426
R 1107	MR25	1% 261E	5322 116 54502
R 1108		0.1% 1K33	5322 116 53206
R 1109		0.1% 147E	5322 116 53199
R 1110	MR25	1% 133K	5322 116 54708
R 1111	MR25	1% 14K7	5322 116 54632
R 1112	MR25	1% 10K	4822 116 51253
R 1113	MR25	1% 1K	4822 116 51235
R 1114	MR25	1% 22K6	5322 116 50481
R 1115	MR25	1% 100K	4822 116 51268
R 1116	MR25	1% 1K	4822 116 51235
R 1151	MR25	1% 19E6	5322 116 50473
R 1152	2.2A	15E	5322 116 34035
R 1153	Shunt assy		5322 209 50548 see figure 4.3 and 8.1
R 1154	MR25	1% 100K	4822 116 51268
R 1201		245V 750E-1K5	5322 116 44006
R 1202		245V 750E-1K5	5322 116 44006
R 1203		0.25% 2K52	5322 116 53195
R 1204	MR25	1% 4K42	5322 116 50556
R 1205		0.25% 357K	5322 116 53196
R 1206	MR25	1% 10K	4822 116 51253
R 1207		0.25% 845K	5322 116 53204
R 1208		0.25% 14K	5322 116 53194
R 1209	MR25	1% 10K	4822 116 51253
R 1210		0.25% 249K	5322 116 53205
R 1211		0.25% 249K	5322 116 53205
R 1213	MR25	1% 100K	4822 116 51268
R 1301	MR25	1% 10K	4822 116 51253
R 1302	MR25	1% 681K	5322 116 55284
R 1303	MR30	1% 511K	5322 116 55636
R 1304	MR30	1% 511K	5322 116 55636
R 1305	MR25	1% 681K	5322 116 55284
R 1306	MR25	1% 2K55	5322 116 54577
R 1307	MR25	1% 162K	5322 116 54716
R 1308	MR25	1% 2K05	5322 116 50664
R 1309	MR25	1% 20K5	5322 116 55419
R 1310	MR25	1% 16K9	5322 116 54635
R 1311	MR25	1% 48K7	5322 116 50442
R 1401	MR25	1% 10K	4822 116 51253
R 1402	MR25	1% 10K	4822 116 51253
R 1403	MR25	1% 1K	4822 116 51235
R 1404	MR25	1% 10K	4822 116 51253
R 1405	MR25	1% 14K7	5322 116 54632
R 1406	MR25	1% 10K	4822 116 51253
R 1407	MR25	1% 8K25	5322 116 51498
R 1411	MR25	1% 64K9	5322 116 50514
R 1412	MR25	1% 3K48	5322 116 55367
R 1413	MR25	1% 10K	4822 116 51253
R 1414	MR25	1% 10K	4822 116 51253
R 1415	MR25	1% 10K	4822 116 51253
R 1416	MR25	1% 10K	4822 116 51253
R 1417	MR25	1% 1K21	5322 116 54557
R 1418	MR25	1% 1E47	5322 116 55604
R 1419	MR25	1% 5K9	5322 116 50583
R 1420	MR25	1% 1K	4822 116 51235
R 1421	MR25	1% 10K	4822 116 51253
R 1422	MR25	1% 121K	5322 116 54704
R 1423	MR25	1% 1K	4822 116 51235

posno.	description			ordering no.		
R 1425	MR25	1%	11E	5322	116	54059
R 1426	MR25	1%	2K15	5322	116	50767
R 1431	MR25	1%	5K62	4822	116	51281
R 1432	MR25	1%	4K02	5322	116	55448
R 1433	MR25	1%	4K42	5322	116	50556
R 1434	MR25	1%	10K	4822	116	51253
R 1435	MR25	1%	10K	4822	116	51253
R 1436	MR25	1%	10K	4822	116	51253
R 1437	MR25	1%	10K	4822	116	51253
R 1438	MR25	1%	10K	4822	116	51253
R 1439	MR25	1%	10K	4822	116	51253
R 1440	MR25	1%	10K	4822	116	51253
R 1441	-101-333		33K	5322	111	90881
R 1451	MR25	1%	1K	4822	116	51235
R 1452		0.1%	3K09	5322	116	53201
R 1453		0.25%	1K54	5322	116	53192
R 1454		0.25%	768E	5322	116	53193
R 1455	MR25	1%	383E	5322	116	55368
R 1456		0.1%	10K	5322	116	53198
R 1457		0.1%	1K58	5322	116	53197
R 1458		0.25%	187E	5322	116	53191
R 1459	MR25	1%	95E3	5322	116	50569
R 1460	MR25	1%	46E4	5322	116	50492
R 1461	MR25	1%	46E4	5322	116	50492
R 1462	MR25	1%	1K54	5322	116	50586
R 1463		0.1%	10K	5322	116	53198
R 1464		0.1%	10K	5322	116	53198
R 1470	MR25	1%	1M	5322	116	55535
R 1501	MR25	1%	100E	5322	116	55549
R 1502	MR25	1%	100E	5322	116	55549
R 1503	MR25	1%	100E	5322	116	55549
R 1504	MR25	1%	100E	5322	116	55549
R 1505	MR25	1%	287E	5322	116	54506
R 1506	MR25	1%	100E	5322	116	55549
R 1507	MR25	1%	100E	5322	116	55549
R 1508	MR25	1%	100E	5322	116	55549
R 1509	MR25	1%	100E	5322	116	55549
R 1510	MR25	1%	100E	5322	116	55549
R 1511	MR25	1%	100E	5322	116	55549
R 1512	MR25	1%	5K9	5322	116	50583
R 1513	MR25	1%	5K9	5322	116	50583
R 1514	MR25	1%	5K11	5322	116	54595
R 1515	MR25	1%	11K	5322	116	54623
R 1516	MR25	1%	11K	5322	116	54623
R 1517	MR25	1%	715E	5322	116	50571
*8 R 1518	MR25	1%	287E	5322	116	54506
R 1519	MR25	1%	10K	4822	116	51253
R 1520	MR25	1%	287E	5322	116	54506
R 1521	MR25	1%	10K	4822	116	51253
R 1522	MR25	1%	100E	5322	116	55549
R 1523	MR25	1%	100E	5322	116	55549
R 1531	MR25	1%	13K3	5322	116	55276
R 1532	MR25	1%	10K	4822	116	51253
R 1533	MR25	1%	10K	4822	116	51253
R 1534	MR25	1%	1K	4822	116	51235
R 1535	MR25	1%	22K6	5322	116	50481
R 1601	MR25	1%	619E	4822	116	51232
R 1602	MR25	1%	2K26	5322	116	50675
R 1603	351V 429V	10%		5322	116	21072
*8 R 1604	MR25	1%	1K	4822	116	51235

posno.	description	ordering no.
R 1701	MR25 1% 1K	4822 116 51235
R 1702	-105-103 10K	5322 111 90473
R 1703	MR25 1% 100E	5322 116 55549
R 1704	MR25 1% 100E	5322 116 55549
R 1705	MR25 1% 10K	4822 116 51253
R 1706	MR25 1% 10K	4822 116 51253
R 1707	MR25 1% 10K	4822 116 51253
R 1708	MR25 1% 10K	4822 116 51253
R 1709	MR25 1% 100K	4822 116 51268
R 1713	MR25 1% 1K	4822 116 51235
R 1802	MR25 1% 4K64	5322 116 50484
R 1803	MR25 1% 100K	4822 116 51268
R 1804	MR25 1% 100K	4822 116 51268
R 1805	MR25 1% 18K7	5322 116 55362
R 1806	MR25 1% 2K05	5322 116 50664
R 1807	MR25 1% 301K	5322 116 54743
R 1808	MR25 1% 226E	5322 116 54497
R 1809	MR25 1% 226E	5322 116 54497
R 1810	MR25 1% 8K25	5322 116 51498
R 1811	MR25 1% 11K	5322 116 54623
R 1812	MR25 1% 11K	5322 116 54623
R 1813	MR25 1% 100E	5322 116 55549
R 1814	MR25 1% 100E	5322 116 55549
R 1815	MR25 1% 10K	4822 116 51253
R 1816	MR25 1% 2K74	5322 116 50636
R 1817	MR25 1% 1K	4822 116 51235
R 1818	MR25 1% 100K	4822 116 51268
R 1819	MR25 1% 30K1	5322 116 54655
R 1820	MR25 1% 4K64	5322 116 50484
R 1821	MR25 1% 1M	5322 116 55535
*8 R 1822	MR25 1% 10K	4822 116 51253
R 1823	MR25 1% 10K	4822 116 51253
R 1901	MR25 1% 100E	5322 116 55549
R 1902	MR25 1% 100E	5322 116 55549
R 1903	MR25 1% 10K	4822 116 51253
R 1904	MR25 1% 10K	4822 116 51253
*13 R 1905	MR25 1% 1M	5322 116 55535
R 1906	MR25 1% 100E	5322 116 55549
R 1907	MR25 1% 100E	5322 116 55549
R 1908	MR25 1% 2K74	5322 116 50636
R 1909	MR25 1% 4K64	5322 116 50484
R 1910	MR25 1% 100E	5322 116 55549
R 1911	MR25 1% 121E	5322 116 54426
R 2101	MR25 1% 196K	5322 116 55364
R 2102	MR25 1% 3K48	5322 116 55367
R 2103	MR25 1% 3K32	4822 116 51247
R 2104	MR25 1% 590E	5322 116 50561
R 2105	CTP10 20% 220E	4822 100 10019
R 2201	MR25 1% 10K	4822 116 51253

8.2.3 Semiconductors

posno.	description		ordering no.
V 1103	BAS45	PEL	5322 130 32256
V 1104	BAW62	PEL	4822 130 30613
V 1105	BAW62	PEL	4822 130 30613
V 1106	BZX79-C4V3	PEL	4822 130 31554
V 1107	BZX79-C4V3	PEL	4822 130 31554
V 1108	BZV85-C5V6		4822 130 32904
V 1109	BZV85-C5V6		4822 130 32904
V 1110	BF256A	PEL	5322 130 44418
V 1111	BC559B	PEL	4822 130 44358
V 1112	BAW62	PEL	4822 130 30613
V 1151	BC337	PEL	4822 130 40855
V 1152	BC337	PEL	4822 130 40855
V 1153	BT139-600	PEL	5322 130 24079
V 1154	BFW13	PEL	5322 130 40516
V 1201	BF256B	PEL	5322 130 44744
V 1202	BFW13	PEL	5322 130 40516
V 1203	BC337	PEL	4822 130 40855
V 1204	BC337	PEL	4822 130 40855
V 1205	BC337	PEL	4822 130 40855
V 1206	BC549C	PEL	4822 130 44246
V 1207	BC549C	PEL	4822 130 44246
V 1208	BAW62	PEL	4822 130 30613
V 1209	BAW62	PEL	4822 130 30613
V 1210	BAW62	PEL	4822 130 30613
V 1301	BSV80	PEL	5322 130 34044
V 1303	BF256B	PEL	5322 130 44744
V 1304	BSV80	PEL	5322 130 34044
V 1401	BAS45	PEL	5322 130 32256
V 1402	BAS45	PEL	5322 130 32256
V 1403	BF256B	PEL	5322 130 44744
V 1404	BAW62	PEL	4822 130 30613
V 1405	ON528	PEL	5322 130 44405
V 1406	BAW62	PEL	4822 130 30613
V 1407	BF256B	PEL	5322 130 44744
V 1408	BAW62	PEL	4822 130 30613
V 1409	BAW62	PEL	4822 130 30613
V 1451	BAW62	PEL	4822 130 30613
*5 V 1452	ZENER SPEC.	PEL	5322 130 80211
V 1453	BAW62	PEL	4822 130 30613
V 1501	BC547B	PEL	4822 130 40959
V 1502	BC547B	PEL	4822 130 40959
V 1503	BAX12 DO-35	PEL	5322 130 34605
V 1504	BAX12 DO-35	PEL	5322 130 34605
V 1505	BAX12 DO-35	PEL	5322 130 34605
V 1506	BAX12 DO-35	PEL	5322 130 34605
V 1507	BAX12 DO-35	PEL	5322 130 34605
V 1508	BAX12 DO-35	PEL	5322 130 34605
V 1509	BAX12 DO-35	PEL	5322 130 34605
V 1510	BAX12 DO-35	PEL	5322 130 34605
V 1531	BAW62	PEL	4822 130 30613
V 1532	BAW62	PEL	4822 130 30613
V 1601	BYW54	PEL	5322 130 34919
V 1602	BYW54	PEL	5322 130 34919
V 1611	BAX18	PEL	4822 130 34121
V 1612	BAX18	PEL	4822 130 34121
V 1613	BAX18	PEL	4822 130 34121
V 1614	BAX18	PEL	4822 130 34121
V 1615	BAX18	PEL	4822 130 34121
V 1616	BZX79-C3V3	PEL	5322 130 31504
V 1617	BAX18	PEL	4822 130 34121
V 1618	BZV46-C1V5	PEL	5322 130 34865
V 1619	BAX18	PEL	4822 130 34121

posno.	description		ordering no.
V 1620	BAX18	PEL	4822 130 34121
V 1621	BAX18	PEL	4822 130 34121
V 1622	BZX79-B3V9		4822 130 31981
V 1701	BAW62	PEL	4822 130 30613
V 1702	BAW62	PEL	4822 130 30613
V 1703	BZX79-B3V9	PEL	4822 130 31981
V 1706	BC547B	PEL	4822 130 40959
V 1707	BAW62	PEL	4822 130 30613
V 1801	BC559B	PEL	4822 130 44358
V 1802	BAW62	PEL	4822 130 30613
V 1803	BC547B	PEL	4822 130 40959
V 2101	BZV46-C1V5	PEL	5322 130 34865
V 2102	BC547B	PEL	4822 130 40959

8.2.4 Integrated circuits

	posno.	description	ordering no.
*11	D 1301	OQ0068A	5322 209 81884
	D 1401	DEVICE SPEC. (OQ0301)	5322 209 11127
	D 1402	HEF4051BD PEL	4822 209 10262
	D 1403	HEF4066BD PEL	5322 209 10357
*8	D 1501	OQ 0300A	5322 209 11126
	D 1511	PCF8574P PEL	5322 209 10883
	D 1512	PCF8574P PEL	5322 209 10883
	D 1513	SAA1300 PEL	4822 209 81338
	D 1531	HEF4013BD PEL	4822 209 10248
*14	D 1701	P8031AH INT	5322 209 11128
*14	D 1701	P80C31	5322 209 73932
*14	D 1702	SN74LS373 T.I	5322 209 86062
*14	D 1702	74HC373	5322 209 11366
*7	D 1703	EPROM PM2534 *14	5322 209 50551 (id. 2583.)
*7	D 1703	EPROM PM2535 *14	5322 209 50712 (id. 2590.)
*6	D 1703T	TESTROM	5322 694 54039
*9	D 1705	CDM6116 (2kx8 S-RAM)	5322 209 83103 (PM2534, old versions)
*9	D 1705	CDM6264 (8kx8 S-RAM)	5322 209 50644 (PM2534 + PM2535)
*8	D 1801	OQ 0300A	5322 209 11126
	D 1802	HEF4528BD PEL	4822 209 10277
	D 1901	SA1045	5322 209 83269
*13	D 1902	MAF8441P/T008	5322 209 11131
*13	D 1902	PCF84C41	5322 209 62359
	D 1903	SN74LS02N T.I	5322 209 85312
	D 1904	SN74LS05N T.I	5322 209 84994
	D 1905	SN75160AN T.I	5322 209 81807
	D 1906	SN75161AN T.I	5322 209 81842
	D 2101	PCF8576T PEL	5322 209 11129
	D 2201	PCF8574P PEL	5322 209 10883
	N 1101	LTC1052CN8 L.T	5322 209 83378
	N 1201	UA308ATC FSC	5322 209 83377
	N 1401	LF356N N.S	5322 209 86422
	N 1402	NE5532P T.I	5322 209 81919
	N 1403	LM311N N.S	5322 209 85503
	N 1404	DAC-08EP PMI	5322 209 83154
	N 1405	UA308ATC FSC	5322 209 83377
	N 1406	UA308ATC FSC	5322 209 83377
	N 1531	LM358N N.S	4822 209 81472
	N 1601	UA7805UC FSC	5322 209 84841
	N 1611	LM78L05ACZ N.S	5322 209 80903
	N 1612	LM78L05ACZ N.S	5322 209 80903
	N 1613	LM337T N.S	5322 209 81236
	N 1614	LM79L05ACZ N.S	5322 209 86434
	N 1801	TL7705ACP T.I	4822 209 82386
	H 1801	CNX36 PEL	5322 130 90097
	H 1803	CNX36 PEL	5322 130 90097
	H 1804	CNX36 PEL	5322 130 90097
	H 1805	CNX36 PEL	5322 130 90097
	H 1807	PS20-01-0	5322 280 10148

8.2.5 Miscellaneous

posno.	description	ordering no.
G 1601	3 V 1,2 Lithium batt 17X33	5322 138 10223
G 1701	UNIT 12000 KHZ	5322 242 71226
G 1901	6000,000KHZ	4822 242 70392
{ K 0001	1MC 500VDC CONTACT	5322 280 20162
{ K 0002	9V COIL	5322 281 60162
{ K 1101	Relay special	5322 280 20163
K 1102	5 V.	5322 280 20339
K 1151	6VDC DIPS	5322 280 20159
K 1201	5 V.	5322 280 20122
K 1202	5VDC 1A	5322 280 20161
K 1203	5 V.	5322 280 20339
K 1301	5VDC 1A	5322 280 20161
K 1302	5 V.	5322 280 20339
K 1303	5 V.	5322 280 20339
L 0001	H F CHOKE 3B	5322 158 10052
L 0002	H F CHOKE 3B	5322 158 10052
X 0001	TRIGGER INPUT (BNC-plug)	4822 267 14027
X 002	MAINS CONNECTOR	5322 265 30406
X 1201	8-P CONNECTOR	5322 267 54107
X 1202	8-P CONNECTOR	5322 267 54107
X 1901	9-P CONNECTOR	5322 267 50594
X 1902	24P IEEE-488 CONNECT.	5322 267 60162
X 1903	10-P CONNECTOR	5322 265 40485
X 2101	7P. CONNECTOR	5322 265 40486
G 1401	5.000.000 kHz (ADC - 50 Hz)	5322 242 70362
G 1401	6.000.000 kHz (ADC - 60 Hz)	5322 242 70392
*4 T 1601	Mains transformer	5322 148 60189

9. CIRCUIT DIAGRAMS AND PRINTED CIRCUIT BOARDS LAY-OUTS

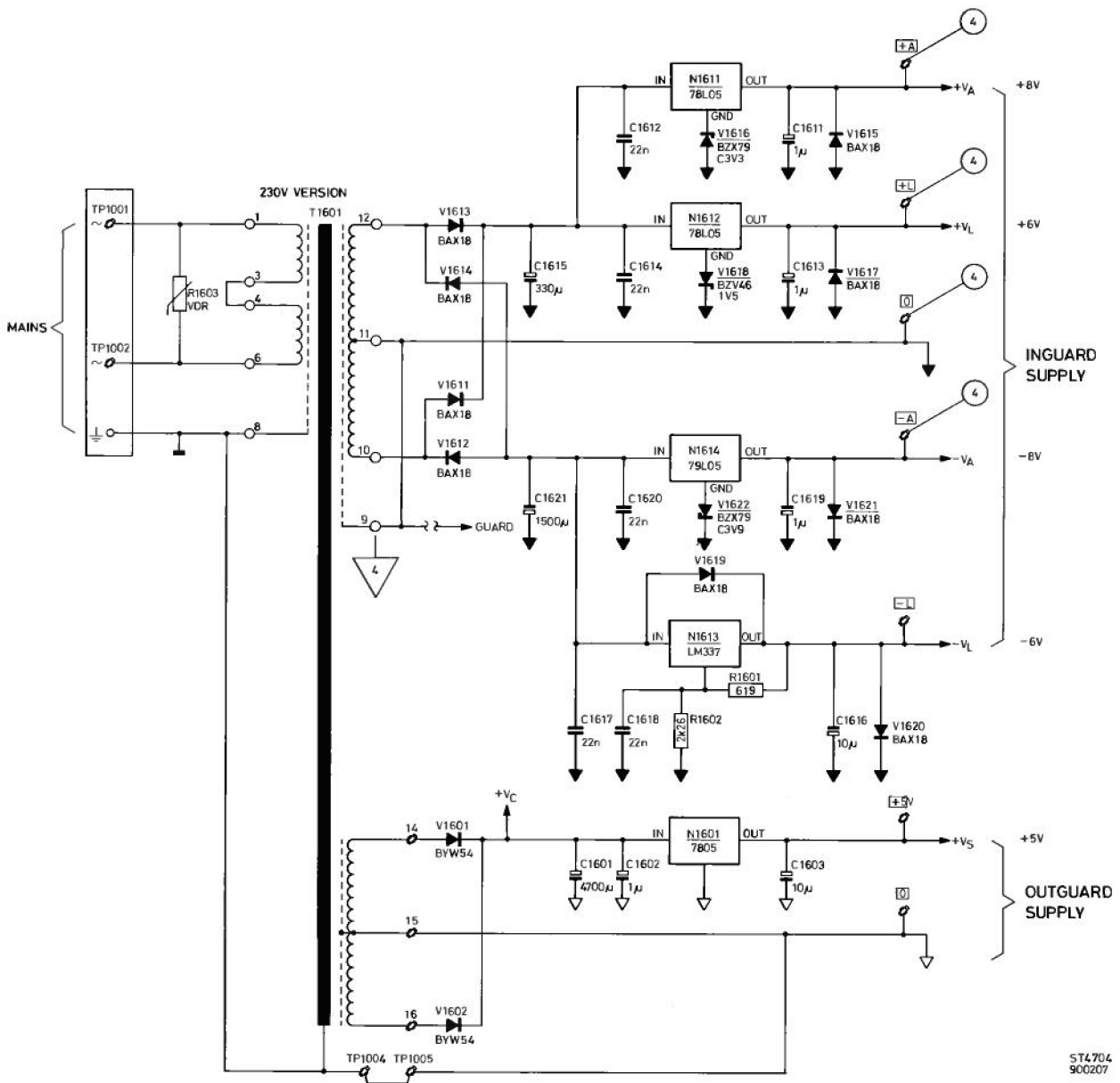

ST4704
900207

Figure 9.1 Power supply

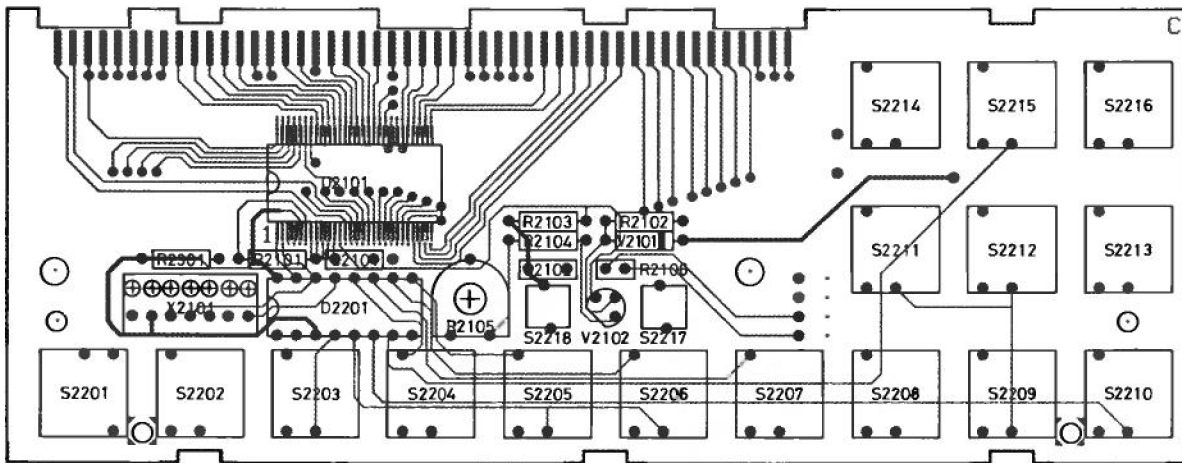

ST4739
850809

Figure 9.2 Display pcb, component side

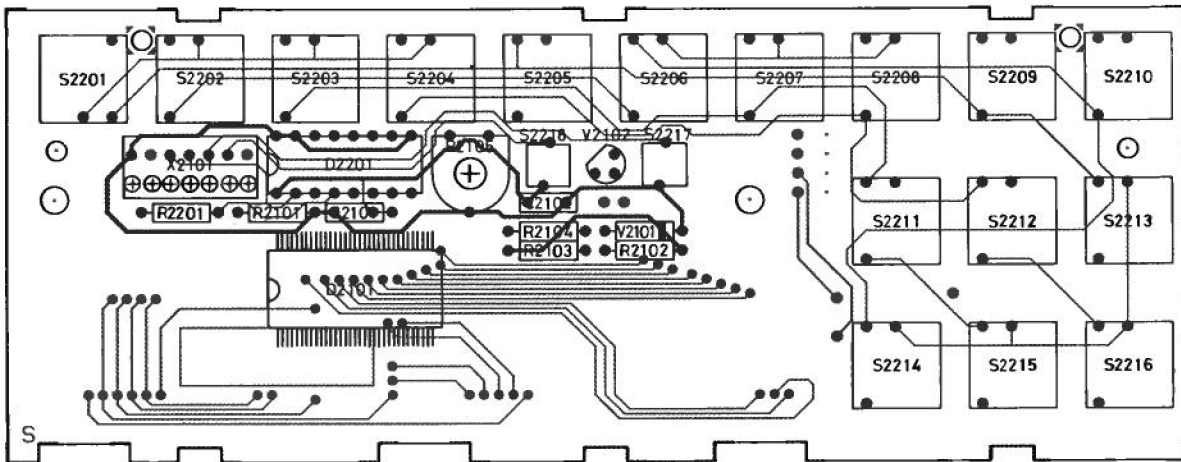

ST4801
860305

Figure 9.3 Display pcb, solder side

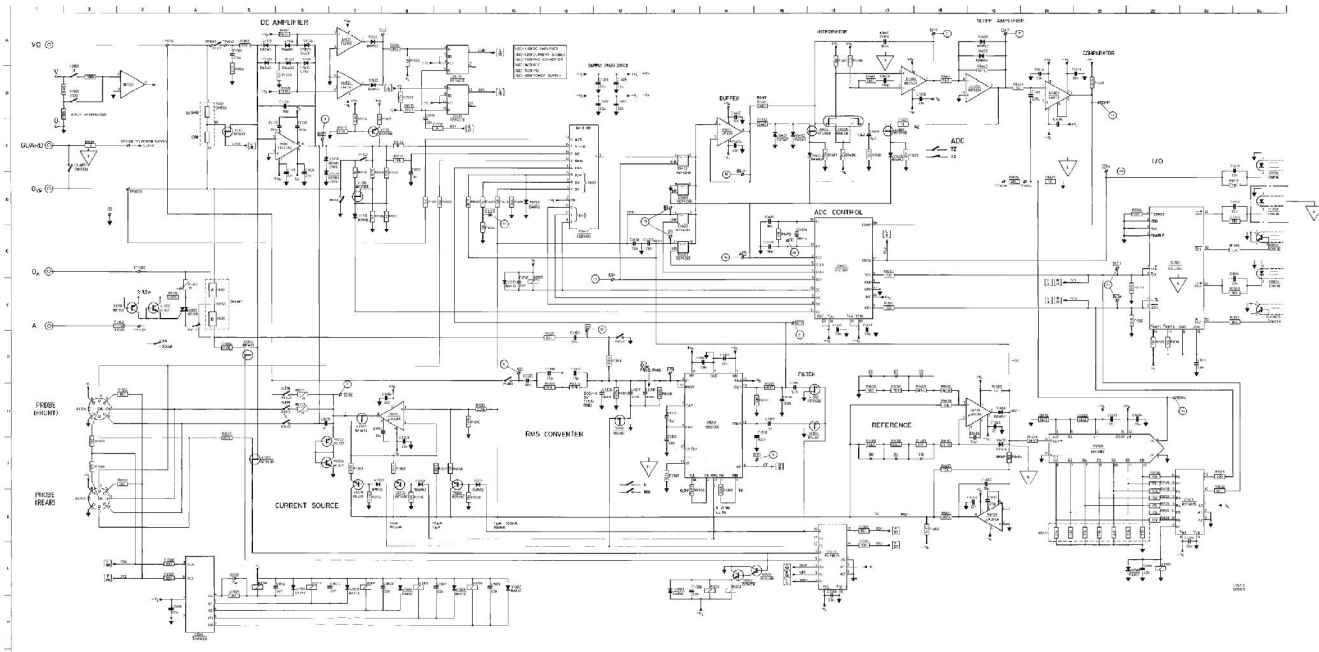

Figure 9.5 Main pcb, analog part circuit diagram

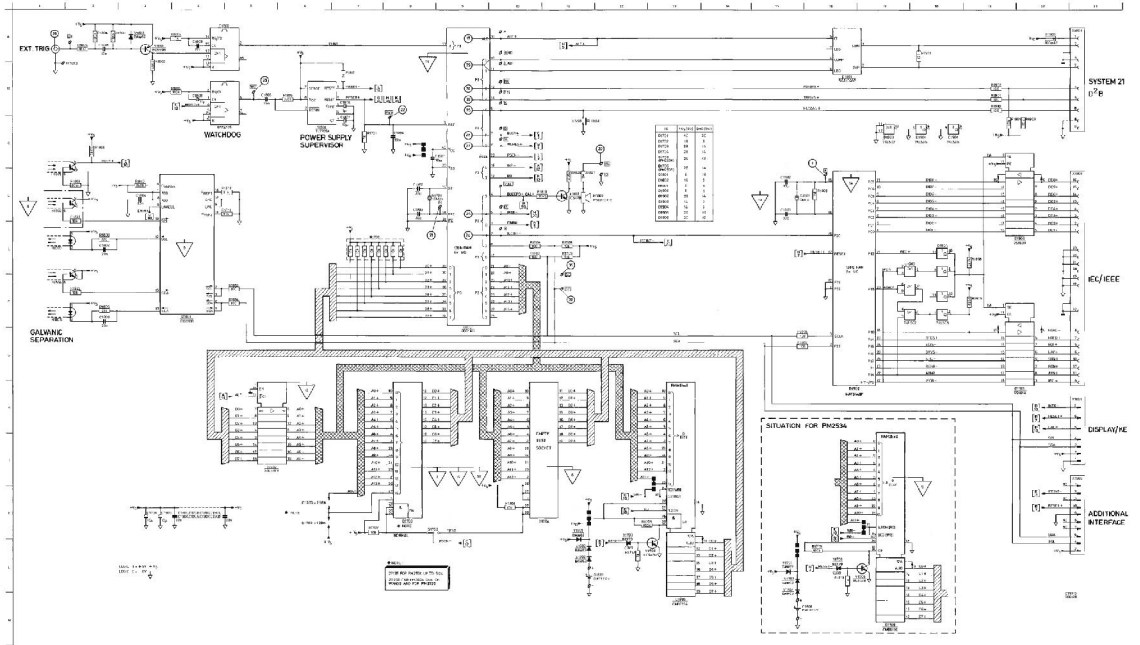

Figure 9.6 Main pcb, digital part circuit diagram

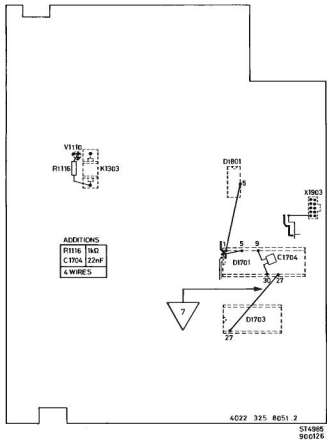

Figure 9.7 Main pcb version 4022 325 8051.2 additional components

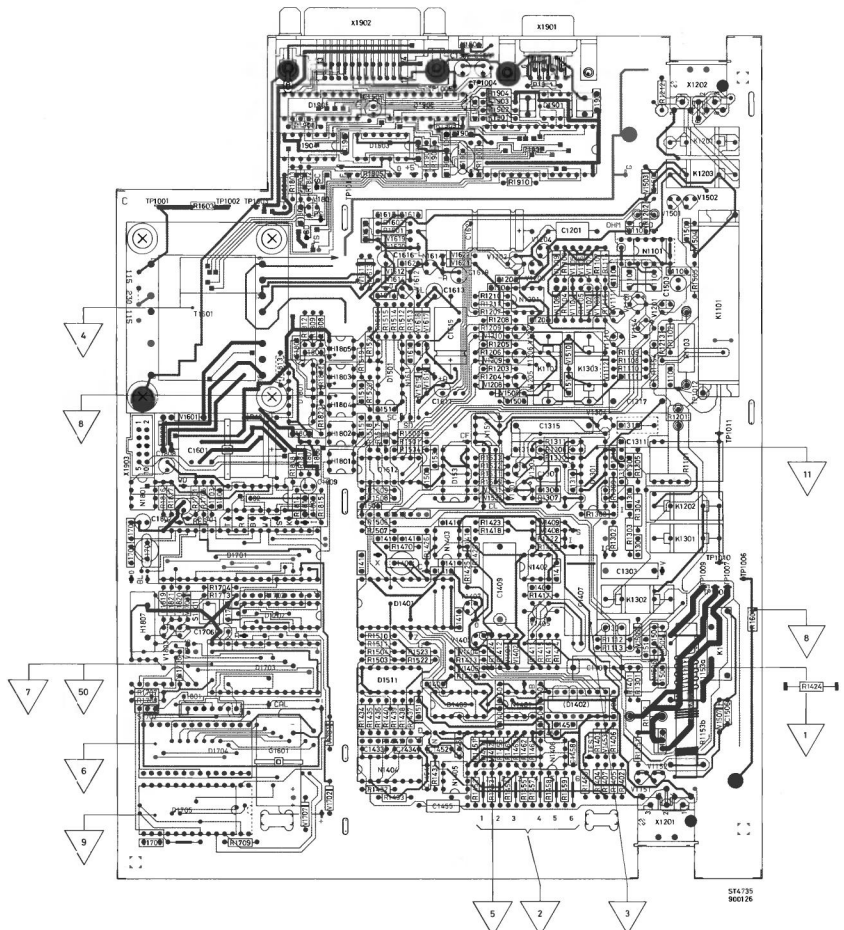

Figure 9.8 Main pcb version 4022 325 8051.2, component side

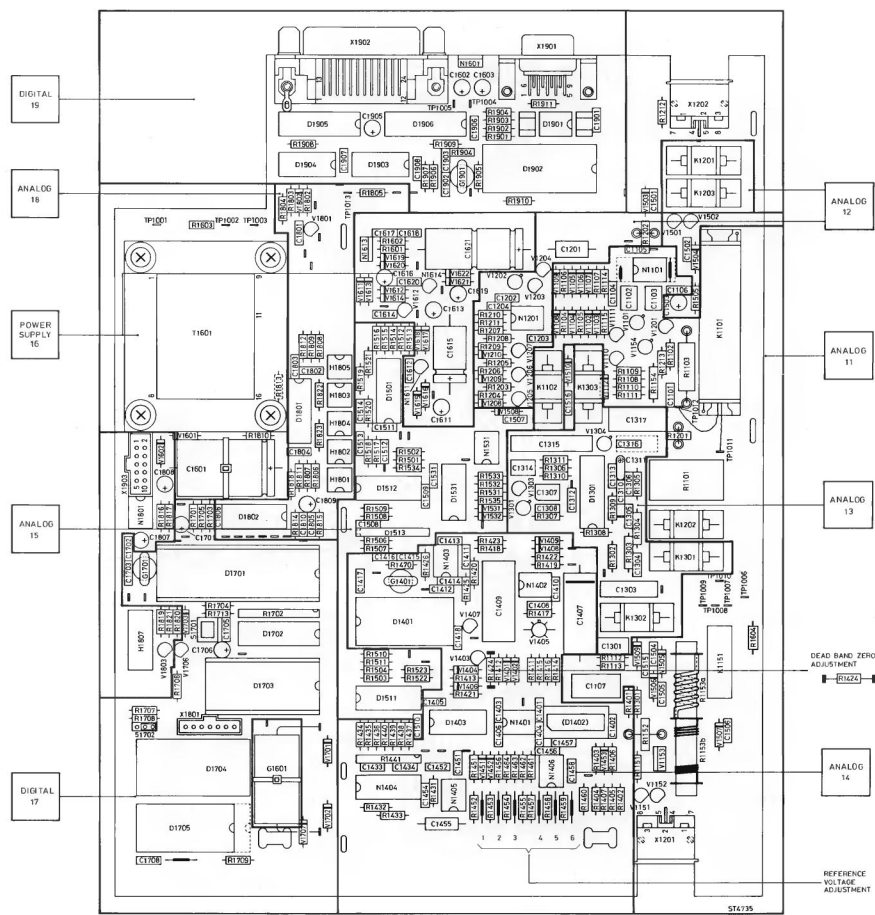

Figure 9-12 Main pcb parts location (version 4022 325 8051.3, almost equal to version 4022 325 8051.2) ST484 900126

10. GLOSSARY OF TERMS

AO-A14	Address lines
ALE	Address Latch Enable
ATAACK	Attention acknowledge
ATN	Attention
ATNR	Attention received
CAL	Calibrate
CFI	Crest factor indication
DO-D7	Data lines
DAV	Data valid
DAVS	Data valid send
ENINI	Enable I ² C transport
ENINT	Enable interrupt
EOI	End or identity
EOIS	End or identity send
EXINT	External interrupt
IECINT	IEC interrupt
IFC	Interface clear
IFCR	Interface clear received
INTK	Interrupt keyboard
NDAC	No data accepted
NRFD	Not ready for data
OL	Overload (on display ↑)
PSEN	Program store enable
RxD	Receive data
RDYSYS	Ready System 21
RD	Read data
REC	Receive
REF+	Positive reference
REF-	Negative reference
REN	Remote enable
RENR	Remote received
RESET	Reset
RESSYS	Reset System 21
RFDS	Ready for data send
SCL	Serial clock
SDA	Serial data
SRQ	Service request
TXD	Transmit data
TA	Talker active
TRISYS	Trigger System 21
WDRES	Watchdog reset
WR	Write

MODIFICATIONS

11.1 Hardware modifications

Modifications described in this manual are indicated on the relevant place in this documentation by a mark *x or

mark the number (x) corresponds to the modification number described below

Printed circuit board versions

For some modifications reference is made to the printed circuit board version. This number is placed on the left front edge of the p.c.b. component side. It becomes visible when you remove the front assembly, refer to section 4.4.

The following pcb versions are used:

- | | |
|-----------------|--|
| 4022 325 8051.2 | First pcb version delivered.
Used in the:
PM2534 up to serial number DY0102166
PM2535 up to serial number DY0101370 |
| 4022 325 8051.3 | Modifications in the previous pcb are incorporated in the print lay-out.
Used in present deliveries of the PM2534 and PM2535. |
| 4022 325 8051.4 | Minor modifications; positioning of IEEE-bus connector X1902 improved.
Used in future deliveries of the PM2534 and PM2535. |

Modifications

- | | |
|-------------|---|
| 1. Problem: | non-linearity |
| Cause: | deviation in the ADC |
| Remedy: | additional ADC adjustment |
| Action: | in case the meter shows a non-linear behaviour, you must adjust the DEAD BAND ZERO, as described in section 5.2, part A-2 (page 5.4).
The adjustment can be carried out in all instruments. In old instruments no solder pins for R1424 may be provided. |

2. Problem: reference numbers of the reference voltage adjustment wires not indicated.
Remedy: drawings are updated.
3. Problem: instability in the Vac ranges.
Cause: interference susceptibility of C1407.
Remedy: C1407 must be mounted with the marking (bar) at the correct side.
Action: Check the mounting position of C1407 if the instrument shows instability on the Vac ranges (see MAIN pcb lay-out).
4. Problem: instability in the 300 mV dc range, speed 4
Cause: introduction of a new, VDE approved, mains transformer (T1601).
Remedy: the screen (pin 9) of the transformer is disconnected from the guard and connected to the zero of the in-guard supply (pin 11 of the transformer).
Action: if you replace an old transformer T1601 by a new one, you must:
- cut the trace between T1601:9 and test pin G (uard) at the component side of the main pcb (version 4022 325 80512)
- interconnect pins 9 and 11 of T1601 at the conductor side
- Old transformers are marked with number 4022 369 7063x; new transformers with 4022 369 7100x. The x is the version number. Transformers delivered by Concern Service are of the new type. For ordering code see PARTS LIST 8.2.5.
5. Problem: the Vdc ranges are out of specification within the re-calibration period.
Cause: long term drift of the ADC reference zener diode V1452.
Remedy: the diodes are aged before use; pre-aged diodes are marked with a black bar in the axial direction.
Introduction: Aged diodes are used in the:
PM2534, from DY0101520 onwards
PM2535, from DY0100908 onwards

Action: if an involved instrument goes out of its specification within the re-calibration period, you must replace V1452 by an aged type (marked with a black bar). See PARTS LIST 8.2.3. for the ordering code.

6. **Concerns:** test ROM D1704

Modification: - the test ROM socket will be omitted
- a 256 K instead of a 64 K EPROM is used for the test programs. The test software has not been changed!

Reason: - socket not required
- as the socket is omitted, the test ROM must be fitted in the firmware EPROM socket. If the firmware EPROM is a 256 K type (PM2535 and later versions of the PM2534, see modification 7), a 64 K test ROM can not be used. The 256 K test ROM can be used in all instruments!

Action: order a new test ROM 5322 694 54039; the 256 K type will be delivered. If you have already a 64 K test ROM, you can load its contents into a 27C256 EPROM. In this case it must be loaded twice, the first time starting at address 00000 (start address when A14 is low), the second time starting at address 04000 (start address when A14 is high, PM2534 old versions). You can use the old (64 K) testrom in the PM2534 if it is provided with a 128 K firmware EPROM:

- in the firmware EPROM socket: S1702 in position Normal Operation
- in the test rom socket (D1704), if provided: S1702 in Test Operation

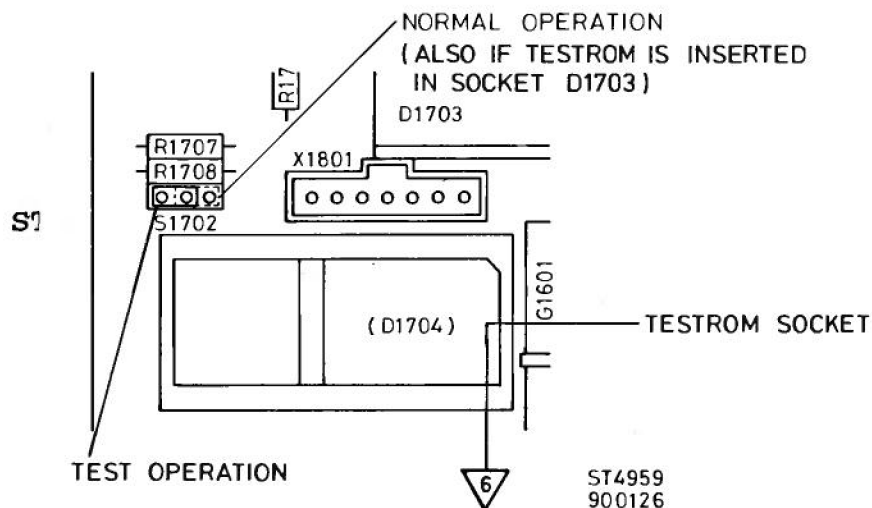

7. **Modification:** the PM2534 firmware is loaded in a 256 K EPROM (was a 128 K EPROM). As a consequence the print has been modified as follows:
 address line A14 of the EPROM (D1703:27) is disconnected from the +5 V supply (+Vs) and then connected to A14 of the μ P (D1701:27).

Reason: In the PM2535 also a 256 K EPROM is used.

Introduction: the 256 K EPROM is introduced in the:

PM2534 from DY0102160 onwards,
 with software version S04
 PM2535 in all instruments

Action: if you want to replace a 128 K firmware EPROM of a PM2534 by a 256 K EPROM (for a software update to S04 or later), you must:
 - remove the socket for D1703 carefully
 - cut the trace between D1703:27 and D1703:28 (component side of main p.c.b. 4022 325 80512)
 - fit the socket
 - interconnect D1703:27 and D1701:27 at the solder side of main pcb 4022 325 80512.
 If you order a firmware EPROM you will receive the latest version. For ordering codes see PARTS LIST 8.2.4, page 8-10.

8. **Problem:** Instrument "hang-up"

Cause: The interference immunity is insufficient. The meter is sensitive to voltage spikes.

Remedy: 1. a new version of the OQ0300, version 4, is installed.

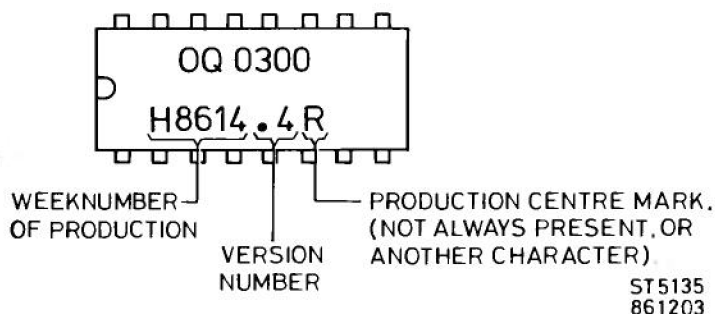

2. the I²C bus in-guard/out-guard isolation circuit has been modified:
 - H1802, C1513, R1518 and R1822 omitted
 - pins 4 (emitter) and 5 (collector) of optocouplers H1803, H1804 and H1805 are interconnected

3. the GUARD terminal is connected to the instrument guard via a 1 k Ω resistor R1604 in one of the following ways:

- 1) according to the figure below

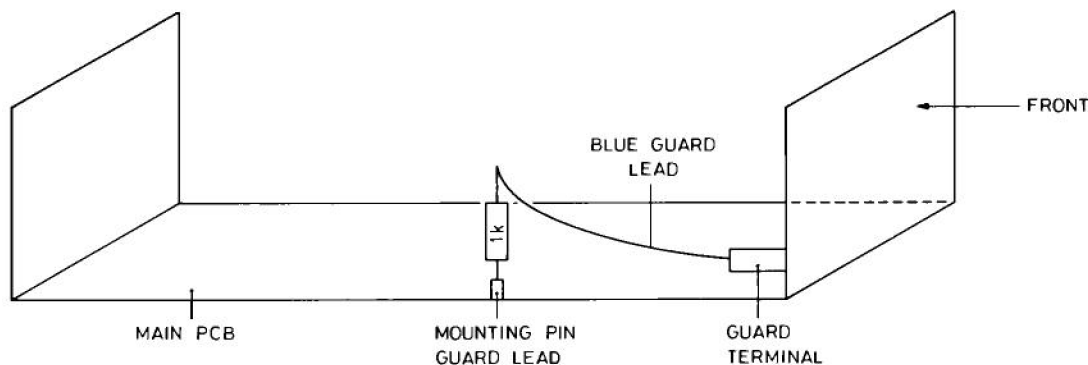

ST5262

- 2) the guard track to TP1006 is cut. A 1 k Ω resistor is soldered across the cut.

Introduction: Modification 1 is introduced in the:

PM2534 from DY0101620 onwards
 PM2535 from DY0100961 onwards

Modifications 2 + 3 are introduced in the:

PM2534 from DY0101808 onwards
 PM2535 from DY0101061 onwards

Action:

1. Replace D1501 and D1801 with version 4 types if old types are installed. Concern Service delivers the new types. For ordering codes see page 8-10.
2. - Remove H1802, C1513, R1518, R1822
 - Interconnect pins 4 and 5 of H1803, of H1804 and of H1805
3. Cut the track between TP1006 and the big solder spot at the other end of this track (see Main pcb 4022 325 80512, solder side). Solder a 1 k Ω resistor (4822 116 51235) across the cut.

9. **Modification:** In the PM2534 the 2K x 8 RAM D1705 has been replaced with a 8K x 8 RAM. The socket for D1705 is omitted.

Reason:

same RAM for the PM2534 and the PM2535

Action:

use the correct type for replacement.

10. NOT USED.

11. Problem: deviation of the 0 Vac indication
- Cause: the selection procedure of the OQ 0068 RMS converter was not carried out correctly.
- Remedy: the OQ 0068 is selected in the correct way.
- Introduction: Correct OQ 0068 IC's are used in:
 PM2534, from DY0102521 onwards
 PM2535, from DY0101612 onwards
- Action: if an involved instrument shows a deviation of zero on the Vac ranges with the input shorted, you must replace D1301. OQ 0068 deliveries from Concern Service are correct and are marked with a paint dot. For ordering see PARTS LIST 8.2.4, p 8-10.
12. NOT USED
13. Modification: - for C1902 and C1903 other capacitance values are used: 5p6 instead of 33pF.
 - R1905 is omitted
 - another type is used for IEEE bus controller D1902: PCF84C41 instead of MAF8441
- Reason: to fulfill the demands of IEEE488-2 and to limit the power consumption.
- Introduction: PM2534 from DY0103168 onwards
 PM2535 from DY0102131 onwards
- Action: if you replace D1902 type MAF 8441 with a PCF 84C41, you must also replace C1902 and C1903 by 5p6 capacitors, and remove R1905. For ordering codes see PARTS LIST 8.2.1 (page 8-4) and 8.2.4 (page 8-10).
14. Modification: some TTL IC's are replaced with CMOS IC's. It concerns:
 D1701, P8031AH ----> P80C31BH
 D1702, 74LS373 ----> 74HC373
 D1703, 27256 -----> 27C256
- Reason: to limit the power consumption.
- Introduction: PM2534 from DY0103168 onwards
 PM2535 from DY0102131 onwards
- Action: if a RS232 interface must be installed, you must carry out this modification, in combination with modification 13. For ordering codes see page 8-10.

11.2 SOFTWARE MODIFICATIONS.

Software modifications are indicated on the relevant place in the documentation by modification number 50

Software versions PM2534

V.	Introduced at ser.no	PROM id. 4022 320	Check sum	Remarks
S01	DY0100611	25834	-	128 K EPROM; install a later version!
S02	DY0100631	25835	F6EE	128 K EPROM
S03	DY0101798	25836	FC34	128 K EPROM
S04	DY0102166	25837	7608	256 K EPROM; see "11.1 HARDWARE MODIFICATIONS, 7"

Software versions PM2535

V.	Introduced at ser.no	PROM id. 4022 320	Check sum	Remarks
S01	none			
S02	DY0100600	25903	B14E	256 K EPROM
S03	DY0101061	25904	A826	256 K EPROM
S04	DY0101370	25905	6C14	256 K EPROM

Modifications S02 ---> S03

Nr. Concerns Description

1 2534-2535 processing of the ADC DEAD BAND ZERO adjustment is improved

Modifications S03 ---> S04

The following errors in S03 have been corrected and improvements are introduced:

- | Nr. | Concerns | Error in S02/S03 - improvement in S04 |
|-----|-----------|--|
| 1 | 2534 | "return to local" procedure must be:
- press CHECK (rtl 0 on display)
- press 1 (rtl 1 on display)
- press END ---> meter returns to local
In S03 the meter also returns to local when rtl 0 is displayed (1 not pressed) and then END is pressed. |
| 2 | 2534 | the display does not always indicate "TALK ONLY" when the talk only mode is selected via the keyboard. However this has been improved, it can still happen in S04. |
| 3 | 2534-2535 | if NULL is pressed (300 mV dc) when the FILTER is on, the displayed value is not 000.0000 mV (at a stable input signal). |
| 4 | 2534 | in the internal trigger mode is the BUSY bit of the status byte sometimes erroneously "0" |
| 5 | 2534-2535 | after a device clear in the internal trigger mode must the BUSY bit be "1"; this was not correct. |
| 6 | 2534-2535 | SRQ (service request) generation when output data is available is not reliable. In S04 this still can cause problems in internal trigger mode, speed 4, display off, help functions off. |
| 7 | 2534 | the IEEE interface is not in "lockout" after a LLO (Local Lock Out) command if the meter is not in the remote mode |
| 8 | 2534 | if NULL is pressed (300 mV dc), the first value should be displayed after approx. 3 seconds; it must be 000.0000 mV (like in the PM2535). This was not correct. |
| 9 | 2534 | PM2534 in remote, keyboard trigger (TRG K); when output data is asked after changing the setting, the instrument sends "999.9999+E9". This is not correct, the instrument may not send anything without a trigger command. |
| 10 | 2534 | behaviour of the PM2534 after a trigger via the BNC plug at the rear, during a measurement, is different from the PM2535. Triggers during a measurement must be ignored. |

- 11 2434-2435 via the interface, the following non existing settings can be programmed:
- ranges 30 M Ω and 300 M Ω in Ohm-4w (PM2534)
- range 3 M Ω , speed 4
- 12 2534-2535 at single trigger or delay on, an internal digital filter was switched on; as a result, previous measurements influenced the actual measurement. With the new software the displayed value is the real measured value after the trigger or delay.
- 13 2534 software version was not displayed during the internal tests (refer to page 6-12)
- 14 2534 in speed 1 it lasts about 3 seconds before the real measurement result becomes available. After about 0.5 seconds however, a so called "partial result" is given as an pre-indication of the measured value. In SINGLE TRIGGER mode this unwanted, but in software version S02 and S03 it occurs after changing the range or function.
- 15 2534 the instrument leaves the TALK ONLY mode on pressing:
CHECK (displays t.ONLY 0) --> END (so without pressing 1).
This must be:
CHECK (t.ONLY 0) --> 1 (t.ONLY 1) --> END
- 16 2534 erroneously an ERROR indication can be given in speed 1 (e.g. OL) or in the CAL mode.
- 17 2534 the command TXT xxxxxx (display text) via the IEEE bus is not always carried out correctly.
- 18 2534 during the CAL mode it is possible to select AUTO RANGING via the interface. This is impossible in S04.
- 19 2534-2535 an erroneous calibration value in a particular function/range, causes a N C indication (not calibrated) in another range/function.
- 20 2534-2535 S04 processes input data for SYSTEM21 faster
- 21 2534 if a dump string containing CAL OFF, is sent to the meter, the STATUS byte reports erroneously a program failure.
- 22 2534-2535 different measurement results for speed 1 and speed 2 (a few counts)

- 23 2534-2535 S04 is better prepared for use of the PM2534 with an optional RS232 interface:
- faster I/O handling via optional interface; slows down the IEEE interface!
 - command EMO is implemented to enable output of measurement data
 - for output data to printer, the meter must be in TALK ONLY mode.
- 24 2534-2535 the execution of long programming strings (over 30 characters) is improved in S04: when a program string is sent, it is interpreted after the last character has been received (was the 30th character). E.g. `OUT_N,6 eoi`. If the comma (,) is the 30th character, in S03 the command is interpreted as "only numeral results must be output". In S04 it is interpreted as "only 6 numeral results must be output".
- 25 2535 lower case characters in the argument of program data were not always allowed (e.g. `OUT_s`). In S04 they are allowed.
- 26 2535 in the measurement data output string, the LIMIT EXCEEDED indication L was not given. In S04 an L is given on the 6th position.
- 26 2535 if the meter is made TALK ONLY in speed 4, the keyboard is locked.
- 27 2535 erroneous display indication of ° (degree), m (milli), k (kilo), M (Mega) in the modes AX+B, dB, % and ZERO (in an activated help function). In S04 this has been omitted.
- 28 2535 if during reading the BURST BUFFER, the burst mode is switched off, the instrument sends rubbish. In S04 the instrument continues with sending normal measurement data.
- 29 2535 if the programming of AX+B or LIMIT via the keyboard is broken off, this resulted in an error in the status byte. In S04 it does not.
- 30 2535 like in the PM2534, in S04 a partial result is displayed in speed 1 (see 14)
- 31 2535 after FILTER ON or OFF, the MIN/MAX buffers are cleared in S04.
- 32 2535 in the error output string 999.9+E09 (at overload), the position of the + and the E must be interchanged. S04 outputs 999.9E+09.

- 33 2535 the ANALOG OUTPUT interface does not function with S02 and S03.
- 34 2535 the only allowed argument type for the commands DMP, MIN, MAX and TST is a question mark (?). In S02 and S03 there was no check on the argument types.
- 35 2534-2535 remote/local protocol for output data is for S04 implemented as follows:
- control via IEEE controller: set multimeter addressable (tONLY 0)
 - IEEE listen only printer connected: set multimeter talk only (tONLY 1), remove other interface options.
 - analog output option: set multimeter tONLY 0
 - RS232 printer connected: set multimeter talk only (tONLY 1)
 - control via RS232 controller: set multimeter addressable (tONLY 0), remote mode (<esc>2).

Errors in S02, S03 and S04 of the PM2534 and PM2535

1. PM2534 and PM2535.

The following commands in combination with the listed selected settings will cause a "program failure" in the status byte. The commands will be correctly executed.

Command	Settings (as returned on DMP command)
MSP 1	(VDC or RTW or RFW) + CAL ON
MSP 2	(IDC or VAC or IAC or TDC) + CAL ON
FIL OFF	(VDC or IDC or RTW or RFW or TDC) + CAL ON
FIL ON	(VAC or IAC) + CAL ON
NULL OFF/ON	CAL ON or MSP 4 or not VDC 300 mV or SCL ON or DBM ON or PRC ON or ZER ON or BUR ON or SEQ ON
SCL OFF[,aaa,bbb]	CAL ON
DBM OFF[,rrr]	CAL ON
PRC OFF[,rrr]	CAL ON
ZER OFF[,rrr]	CAL ON
BUR OFF[,nnn]	CAL ON

2. PM2535

After the command SEQ ON in the calibration mode, the PM2535 recalls its stored settings, even when these settings are not allowed in the calibration mode.

3. PM2534

If in the calibration mode, the PM2534 does not give a program error in the status byte after sending the command FNC TDC via the interface. The command will be executed (°C selected), but the PM2534 does not measure.

Sales and Service all over the world

Algeria

Bureau de Liaison Philips
24 rue Bougainville
El Mouradia, Alger
Tel: 60 14 05
TLX: 62221

Antilles

Philips Antillana N.V.
(For Philips products)
Schottegatweg Oost 146
PO Box 3523
Willemstad, Curacao
Tel: 599-9-615277
Fax: 599-9-612772
TLX: 1047
Tel: 599-9-414071/74*

Argentina

Philips Argentina S.A.
(For Philips products)
Casilla Correo 3479
Vedia 3892
1430 Buenos Aires
Tel: 54-1-5414106/5417141
Fax: 54-1-7869818
Tel: 54-1-5422411/5422451*
TLX: 21359/21243

Coasin S.A.

(For Fluke products)
Virrey del Pino 4071 DEP E-1
1430 CAP FED
Buenos Aires, Argentina
Tel: (54) (1) 552-5248
TLX: (390) 22284 COASN AR

Australia/New Zealand

Philips Scientific & Industrial PTY Ltd.
Test & Measurement Dept.
NZ Head Office
2 Wagner Place
PO Box 4021
Auckland 3
New Zealand
Tel: 09-894160
Fax: 09-862728
TLX: NZ 2395

Australia Head Office

Philips Scientific & Industrial PTY Ltd.
Test & Measurement Dept.
Centre Court 25-27 Paul Street
North Ryde
Sydney New South Wales 2113
Tel: 02-888 0416
Tel: 02-888 8222*
Fax: 02-888 0440
TLX: AA 20165 philind ausnrsi

Philips Scientific & Industrial PTY Ltd.

Test & Measurement
23 Lakeside Drive
East Burwood
Melbourne Victoria 3151
Tel: 03-235 3666
Fax: 03-235 3618

Philips Scientific & Industrial PTY Ltd.

Test & Measurement
348 Torrens Road
Croyden
Adelaide South Australia 5008
Tel: 08-3482888
Fax: 08-3482813

Philips Scientific & Industrial PTY Ltd.

Test & Measurement
299 Montagne Road
West End
Brisbane Queensland 4101
Tel: 07-8440191
Fax: 07-8448537

Philips Scientific & Industrial PTY Ltd.

Test & Measurement
1 Frederick Street
Belmont
Perth West Australia 6104
Tel: 09-277-4199
Fax: 09-277-1202

Austria

Oesterreichische Philips Industrie GmbH
Geschäftsbereich I & E
Marktbereich Test und Messgeräten
Triesterstrasse 64
1101 Wien
Tel: 0222/60101 ext. 1772
Fax: 0222-6272165
TLX: 131670

Oesterreichische Philips Industrie GmbH

Geschäftsbereich I & E
Technischer Kundendienst
Triesterstrasse 64
1101 Wien
Tel: 0222-60101 ext. 818

Bahrain

Messrs. Mohamed Fakhroo & Bros
PO Box 439
Bahrain
Tel: 973-253529
Fax: 973-275996
TLX: 8679 alfaro bn

Bangladesh

Philips Bangladesh Ltd.
(For Philips products)
PO Box 62, Ramna
16/17 Kawaran Bazar C/A
Dhaka
Tel: 325081-5
Tel: 234280*
TLX: 65668

Motherland Corporation

(For Fluke products)
24 Hatkhola Road, Tikatuli
Dacca-3, Bangladesh
Tel: 257249
TLX: (950) 642022 PCO BJ

Belgium

Philips Professional Systems S.A.
Test & Measurement Department
Tweestationstraat 80
1070 Brussel
Tel: 02-525 6692
Tel: 02-525 6694*
Fax: 02-230-2856* yhyg
Fax: 02-525 6483
TLX: 61511 belbrms

Brazil

ATP Hi-Tek Electronica Ltda.
Al. Amazonas 422, Alphaville
06400, Barueri
Sao Paulo, Brazil
Tel: (55) (11) 421-5477
TLX: (391) 1171413 HITK BR

ATP/Hi-Tek Electronica Ltda.

Ave. Henrique Valadares, 23-4
Andar-Sala 401
20231, Rio de Janeiro, RJ Brazil
Tel: (55) (21) 252-1297

Brunei

Brunei (via Singapore)
(For Philips products)
Philips Project Development
(S) PTY Ltd.
Lorong 1, Toa Payoh
Singapore 1231
PO Box 340 Tao Payoh C.P.O.
Tel: 65-3502000
TLX: philips rs/21375

Rank O'Connor's, 5nd Bhd

(For Fluke products)
No. 8 Block D,
Sufri Shophouse Complex
Mile 1 Jalan Tutong
Bandar Seri Begawan
Negara Brunei Darussalam
Tel: (673) (2) 23109 or 23557
TLX: (799) BU 2265 RANKOC

Canada

Fluke Electronics Canada Inc.
400 Britannia Rd. East Unit #1
Mississauga, Ontario
L4Z 1X9 Canada
Tel: (416) 890-7600
Fax: (416) 890-6866

Fluke Electronics Canada Inc.

1690 Woodward Drive
Suite 216
Ottawa, Ontario
K2C 3R8 Canada
Tel: (613) 723-9453
Fax: (613) 723-9458

Fluke Electronica Canada Inc.

1255 Trans Canada Highway
Suite 120
Dorval, Quebec
H9P 2V4, Canada
Tel: (514) 685-0022
Fax: (514) 685-0039

Fluke Electronics Canada Inc.

101, 1144 - 29th Ave. N.E.
Calgary, Alberta
T2E 7P1 Canada
Tel: (403) 291-5215
Fax: (403) 291-5219

Chile

Philips Chilena S.A. de Product Electr.
(For Philips products)
Avenida Santa Maria 0760
Casilla 2678
Santiago de Chile
Tel: 56-2-770038
Fax: 56-2-776730
TXL: 240239

Itronsa

(For Fluke products)
Casilla 16228
Santiago, Chile
Tel: (56) (2) 232-4308
Fax: (56) 2-2322694
TLX: (332) 346351

China, Peoples Republic (via Hong Kong)

Philips Hong Kong Ltd.
(For Philips products)
29 F Hopewell Centre
17 Kennedy Road
G.P.O. Box 2108
Hong Kong
Tel: 852-5-8215888
Fax: 852-5-8655408
TLX: 73660 philh hx

China, People's Republic of Fluke International Corp.

PO Box 9085
Beijing
People's Republic of China
Tel: (86) (1) 512-3435
Fax: (86) 1-512-3437
TLX: (716) 222529 FLUKE CN

Instrimpex - Fluke Service Center

(For Fluke products)
Scite Tower Room 2101
22 Jiam Guo Man Wal Dajie
PO Box 9085
Beijing
People's Republic of China
Tel: 86 01 512-3436

Colombia

Industrias Philips de Colombia S.A.
(For Philips products)
Apartado Aereo 4282
Calle 13 No. 51-39
Bogota
Tel: 57 1-2600600
Fax: 57-1-2610139
TLX: philcolon 44776

Sistemas E Instrumentation, Ltda.

(For Fluke products)
Carrera 21, No. 39A - 21, Of. 101
Ap. Aereo 29583
Bogota, Colombia
Tel: (57) 232-4532
Fax: (57) 1-287-2248

Costa Rica

Electrocom
Apartado 7742
San Jose
Costa Rica
Tel: 53-0083 n.
TLX: 3050 elecrom cr

Cyprus

D. Ouzounian M. Soultanlan & Co. Ltd.

PO Box 1775
45, Evagoras Avenue
Nicosia
Tel: 357-2-442220
Fax: 357-2-459885
TLX: 2315 cy automobil

Denmark

Philips A/S Test & Measurement

Prags Boulevard 80
DK 2300 Kobenhavn S
Tel: (31) 572222
Fax: (31) 570044
TLX: 31201

Egypt

Philips Egypt Branch of Philips Middle East B.V.

10, Abdel Rahman el Rafie st.
PO Box 242
Dokki, Cairo
Tel: 20-2-3490922
Fax: 20-2-3492142
TLX: 22816 phegy un

Ethiopia

Ras Abebe Areguay Avenue
PO Box 2565
Addis Ababa
Tel: 010-231-1-518300
Fax: 251-1-52845
TLX: 021319 phaddis

Finland

OY Philips AB
Sinikalliontie 3
PO Box 75
02631 Espoo
Tel: 0-5026371
Fax: 0-529558
TLX: 1248 1150 Phil
Tel: 0-50261*
Fax: 0-529570*
TLX: 1248 1152 phil*

OY Philips AB*

Kaivokatu 8
PO Box 255
00101 Helsinki 10
Tel: 0-52571

Instrumentarium Elektronika*

PO Box 64 Vitikka 1
02631 Espoo 63
Tel: 0-5281

Sales and Service all over the world

France

S.A. Philips Industrielle et Commerciale
Division Science et Industrie
105 Rue de Paris, BP 62
93002 Bobigny Cedex
Tel: (1) 49428080
Tel: (1) 49428073*
Fax: (1) 49428100
TLX: 235546

Germany

Philips GmbH - EWI
Head Office
Miramstrasse 87
D-3500 Kassel
Tel: 0561-501466
Fax: 0561-501590
TLX: 997070

Philips GmbH - EWI

Martin Luther Strasse 3-7
D 1000 Berlin 30
Tel: 030-21006364
TLX: 185532

Philips GmbH - EWI

Wieselweg 5
D 4300 Essen 11
Tel: 0201-3610-245
Fax: 0201-3610265
TLX: 857-226

Philips GmbH - EWI

Th. Heuss Allee 106
D 6000 Frankfurt 90
Tel: 069-794093-31
Fax: 069-794093-91
TLX: 413611

Philips GmbH - EWI

Meiendorferstrasse 205
D 2000 Hamburg 73
Tel: 040-6797-278
Tel: 040-6797471*
TLX: 2116625

Philips GmbH - EWI

Ikarusallee 1A
D 3000 Hannover 1
Tel: 0511-6786-120
TLX: 923950

Philips GmbH - EWI

Oskar Messterstrasse 18
(For Fluke products)
D 8045 Ismaning
Tel: 089-9605-121
TLX: 21701380 phd, memo =
de73txm

Philips GmbH - EWI

Kilianstrasse 142
D 8500 Nuernberg 12
Tel: 0911-3603293
TLX: 21701 380 phd, memo =
de73txn

Philips GmbH - EWI

Hoehenstrasse 21
D 7012 Fellbach
Tel: 0711-5204-121
Tel: 0711-5204150*
Fax: 0711-5204136
TLX: 7254669

Great Britain

Philips Scientific Test & Measurement
Colonial Way
Watford Herts WD2 4TT
Tel: 0923-240511
Fax: 0923-225067
TLX: 934583 phitmd

Philips Scientific Test & Measurement

Yorkstreet
Cambridge CB1 2PX
Tel: 0223-358866
Fax: 0223-321764
TLX: 817331 phsc cam g

Greece

Philips S.A. Hellénique
PO Box 3153
15, 25th March Street
15 GR 17778 Tavros/Athens
Tel: 30-1-4894911
Fax: 30-1-4815180
TLX: 241566 PHAT GR

Hong Kong

Philips Hong Kong Ltd.
(For Philips products)
29/F Hopewell Centre
17 Kennedy Road
G.P.O. Box 2108
Hong Kong
Tel: 852-5-8215888
Fax: 852-5-8655408
TLX: 73660 phih h x

Schmidt & Co (H.K.), Ltd.

(For Fluke products)
18th Floor, Great Eagle Centre
23 Harbour Road
Wanchai, Hong Kong
Tel: (852) (5) 8330-222
Fax: (852) 5-836-2652
TLX: (780) 74766 or 76762 SCHMC HX

Iceland*

Heimellstaeki S.F.
(For Philips products)
Saetun 8
125 Reykjavik
Tel: 1-691500
Fax: 1-691555

Semeind

(for Fluke products)
Brautarholt 8
125 Reykjavik
Tel: 1-25833
Fax: 1-621531
TLX: 3136 samein is

India

Peico Electronics & Electricals Ltd.
I&E Division
(For Philips products)
Band Box House
254 Dr. Annie Besant Road
Bombay 400 025
Tel: 022 4930311/4930590
Fax: 022-4941698
TLX: 76049

Peico Electronics & Electricals Ltd.

I&E Division
(For Philips products)
7 Justice Chandra
Madhab Road
Calcutta 700 020
Tel: 473621

Peico Electronics & Electricals Ltd.

I&E Division
(For Philips products)
68, Shivaji Marg
New Delhi 110 015
Tel: 530153
Tel: 533956/57*
TLX: 031 3142

Peico Electronics & Electricals Ltd.

I&E Division
(For Philips products)
No 3 Haddows Road
Madras 600 006
Tel: 472341
TLX: 041 499

Peico Electronics & Electricals Ltd.

I&E Division
(For Philips products)
7311 St Mark's Road
Bangalore 560 001
Tel: 579119/579164
TLX: 0845-8185

Hinditron Services Pvt., Ltd.

(For Fluke products)
Industry House
23-B Mahal industrial Estate
Mahakali Caves Road
Andheri (E) Bombay
400 093, India
Tel: (91) (22) 636-4560
(91) (22) 634-8268
Fax: (91) 22-822-0197
TLX: (953) 11-79286 HIPL IN

Indonesia

P.T Daeng Brothers
(For Philips products)
Centre Point Building, 3rd Fl.
Jalan Gatot Subroto Kav. 35/36
PO Box 41 Tebet
Jakarta
Tel: 62-21-5207335
Fax: 62-21-5207550
TLX: 62798 phdc ia

P.T. Lamda Triguna

(For Fluke products)
PO Box 6/JATJG. Jakarta 13001
Indonesia
Tel: (62) (21) 819-5365
Fax: (62) 21-819-9631
TLX: (796) 63938 KA IA

Iran

Philips Iran Ltd.
Private Joint Stock Comp.
PO Box 11365-3891
TEHRAN
Tel: 98-21-674138/675158
TLX: 212545 phps ir

Ireland

Circuit Specialists Ltd.
Unit 5, Enterprise Centre,
Plassey Technology Park
Castleroy, Limerick
Tel: 061 330333

Italy

Philips S.p.A.
Sezione S & I, T & M Dept.
Viale Elvezia 2
20052 Monza
Tel: (039) 3635240/8/9
Fax: 039-3635309
TLX: 333343

Japan

NF Circuit Design
Block Co., Ltd.
(For Philips products)
3-20 Tsunashima Higashi, 6
Chome,
Kokokuku, Yokohama 223
Tel: (045) 452-0411
TLX: 3823-297

Japan

Nihon Philips Corporation*
Shuwa Shinagawa Building
26/38 Tahanawa 3-Chrome
Minatu-ku Tohyo 108
Tel: 4485511

John Fluke Mfg. Co., Inc.

Japan Branch
(For Fluke products)
Sumitomo Higashi Shinbashi Bldg.
1-1-11 Hamamatsucho
Minato-ku, Tokyo 105, Japan
Tel: (81) (3) 434-0181
Fax: (81) 3-434-0170
TLX: (781) 2424331 FLUKJJP

Jordan

Jordan Medical Supplies & Services
PO Box 140415
Al Biader
Amman Jordan
Tel: 962-6-819929
Fax: 962-2-823556
TLX: 22161 jms jo

Kenya

Philips Kenya Ltd.
Ol Kalou Road, Industrial Area
PO Box 30554
Nairobi
Tel: 254-2-557999
Fax: 254-2-543135
TLX: 24033

Korea, Republic of

Myoung Corporation
(For Fluke products)
Yeo Eui Do
PO Box 14
Seoul Korea
Tel: (82) (2) 784-9942
Fax: (82) 2-784-2387
TLX: MYOUNG K24283

South Korea

Philips Industries (Korea) Ltd.
(For Philips products)
CPO Box 3680, Philips House
260-199, Itaewon-Dong
Yongsan-Ku
Seoul
Tel: 82-2-7970378
Fax: 82-2-7978048
TLX: philkor k 27291

Lebanon

Electronic Supplies S.A.R.L.
Autostrade Dora, Hayek Bldg.
PO Box 90 1388
Beyrouth
Tel: 01-894243
TLX: 42950 DIC1

Luxemburg

Philips Luxembourg
Professional Systems S.A.
Rue des Joncs 4
L-1818 Howald
Tel: 496111
Fax: 400577
TLX: 60572

Malaysia

Electronic Systems (Malaysia) Sdn. Bhd.
(For Philips products)
Lot 51 Section 13
Jalan University
Petaling Jaya - Selangor 46200
Tel: 60-3-7560112
Fax: 60-3-7560761

Mecomb Malaysia Sdn. Bhd.

(For Fluke products)
PO Box 24
46700 Petaling Jaya
Selangor, Malaysia
Tel: (60) (3) 774-3422
Fax: (60) 3-774 3414
TLX: (784) MA37764 MECOMB

Malta

Charles A. Micallef & Co. Ltd.
PO Box 527
217 St. Paul str.
Valletta
Tel: 356-234313/233506
TLX: 1651 mica mw

Mexico

Mexicana de Electronica Industrial S.A. (Mexel)
Diagonal No. 27
Entre Calle de Eugenia Y Ave.
Colonia del Valle
C.P. 03100, Mexico
Tel: (90) (5) 680-4323
Fax: (525) 687-8695
TLX: (383) 177 1823 MDEIME

Mexel Servicios en Computacion*

Instrumentation Y Perifericos
Blvd. Adolfo Lopez Mateos No. 163
Col. Mixcoac
Mexico D.F.
Tel: 90-5-563-5411

*Service Center

Sales and Service all over the world

Morocco

Samtel*
2 Rue de Bapaume
Casablanca
Tel: 243050

Somacel

304 Boulevard Mohammed V
Casablanca 05
Tel: 308051/52
TLX: 27021

Nepal

Bahajurana Engineering & Sales (P) Ltd.
(For Philips products)
Jyoti Bhawan
PO Box 133 Kantipath
Kathmandu
Tel: 2-25134
TLX: jyoti np

Associated Enterprises

(For Fluke products)
GPO Box 790, Pyaphal Tole
Kathmandu, Nepal
Tel: 13868
TLX: (947) 2588 ASCENT NP

Netherlands

Philips Nederland B.V.
Test en Meetapparaten
Hoevenseweg 55A
Postbus 115
5000 AC Tilburg
Tel: 013-390112
Fax: 013-427528
TLX: 52683

Philips Nederland

Technische Service Prof. Akt.*
Hurksestraat 2C
Gebouw HBR
5652 AJ Eindhoven

New Zealand

Philips Scientific & Industrial PTY Ltd.
Test & Measurement Dept.
2 Wagner Place
PO Box 4021
Auckland 3
Tel: 09-084-160
Fax: 09-862728
TLX: N2 2395

Nigeria

Associated Electronic Products (Nigeria) Ltd.
KM 16, Ikorodu Road
Ojota
PO Box 1921
Lagos
Tel: 234-1-900160/69
Tel: 234-1-932825*
Fax: 234-1-615601
TLX: 21961 NG

Norway

Norsk Philips AS
Dept. I & E Test & Measurement
Sandstuveien 70
PO Box 1 Manglerud
0612 Oslo 6
Tel: 47-2-356110
Tel: 47-2-680200*
Fax: 47-2-381457
TLX: 856-71719

Oman

Messrs. Mustafa Jawad Trading Co.
PO Box 4918
Ruwi, Sultanate of Oman
Tel: 968-709955
Fax: 968-7972 77
TLX: 3731 mujatra on

Pakistan

Philips Electrical Co. of Pakistan (Private) Ltd.
(For Philips products)
Philips Markaz, M.A. Jinnah Road
PO Box 7101
Karachi 3
Tel: 92-21-725772/9
Fax: 92-21-726694
TLX: 2874 phpak pk

International Operations (PAK Private), Ltd.

(For Fluke products)
505 Muhammadi House
I.I. Chundrigar Road
PO Box 5323
Karachi 2, Pakistan
Tel: (92) (21) 221127
Fax: (92) 21-2411241
TLX: (952) 24494 PIO PK

Paraguay

Philips del Paraguay S.A.
(For Philips products)
Avenida Artigas 1519
Casilla de Correo 605
Asuncion
Tel: 595-21-291924
Fax: 595-21-211662
TLX: py 215

Peru

Philips Peruana S.A.
Carretera Central KM 6.5
Apartado 1841
Lima 1000
Tel: 51-14-350059
Fax: 51-14-423107

Importaciones y Representaciones Electronicas S.A.

(For Fluke products)
Avda. Franklin D. Roosevelt 105
Lima 1, Peru
Tel: (51) (14) 28-8650
TLX: (394) 25663 PE IREING

Philippines, Republic of

Philips Industrial Development Inc.
(For Philips products)
2246, Pasong Tamo
PO Box 911
MCCPO Makati Riazal D
Metro Manila
Tel: 63-2-8100161/69
Fax: 817-3474

Spark Radlo & Electronics, Corp.

(For Fluke products)
PO Box 610, Greenhills
Metro Manila 1502
Philippines
Tel: (63) (2) 775192
Fax: (63) (2) 7220313
TLX: (712) 4005 RLA PH PU

Portugal

Philips Portuguesa, S.A.R.L.
Division of I & E
Test & Measurement
Av. Eng. Duarte Pacheco 6
1009 Lisboa Codex
Tel: 1-657181
Fax: 1-658013

Philips Portuguesa*

Division I & E
Rua Eng Erequil de Campos 182
4100 Porto
Tel: (2) 678278
TLX: 28790

Qatar

Darwish Trading Company
PO Box 92
Doha, Qatar
Tel: 974-422781 ext. 228
Fax: 974-426378
TLX: 4298 tradar dh

Saudi Arabia

Messrs. A. Rajab & A. Silsilah
Head Office
PO Box 203
Jeddah 21411
Tel: 966-2-6610006
Fax: 966-2-6610164-6610558
TLX: 601180 arndas sj

Messrs. A. Rajab & A. Silsilah

PO Box 260
Riyadh 11411
Tel: 966-1-4122425
Fax: 966-1-4122366
TLX: 404787 arndas sj

Messrs. A. Rajab & A. Silsilah

PO Box 587
Dammam
Tel: 966-3-8322596/8331870
Fax: 966-3-8271962
TLX: 601044 arndas sj

Singapore

Philips Project Development (S) PTY Ltd.
(For Philips products)
Lorong 1, Toa Payoh
Singapore 1231, PO Box 340
Toa Payoh Central Post Office
Singapore 9131
Tel: 65-3502000
Fax: 65-2535873
TLX: philips rs/21375

Rank O'Connor's Pte Ltd.

(For Fluke products)
O'Connor House
98 Pasir Panjang Road
Singapore 0511
Republic of Singapore
Tel: (65) 473-7944
Fax: (65) 472-4508
TLX: (766) RS 21023 OCONSIN

South Africa

South African Phillips PTY Ltd.
I & E Division Test & Measurement
10 Bondstreet, Randburg
Johannesburg 2000
Tel: 27-11-889-3911
Fax: 27-11-889-3098/889 3191
TLX: 4-26152-sa

South African Phillips PTY Ltd.*

I & E Customer Support Centre
195 Mai Road, PO Box 58088
Martindale, New Ville 2092
Tel: 27-11-470-5937
Fax: 27-11-470-5166
TLX: 4-26152 SA

Spain

Philips Iberica SAE
Depto Instrumentacion de Medida
Poligono Industrial Zona Franca
Sector C-calle F
08004 Barcelona
Tel: 34-3-3361061
Fax: 34-3-3355838
TLX: 51293/59292

Philips Iberica*

Depto Instrumentacion de Medida
Martinez Villergas 2
28027 Madrid
Tel: 34-1-4042200
Fax: 34-1-4048603
TLX: 27710

Philips Iberica SAE*

Jose Olabarria 6
48012 Bilbao
Tel: 34-4-4313800
Fax: 34-4-432 0961
TLX: 31230

Sri Lanka

Hayleys Electronics & Engineering Ltd.
(For Philips products)
PO Box 70
400 Deans Road
Colombo 10
Tel: 599087
Fax: 598786
TLX: 21146/21384

Computerlink Data Systems, Ltd.

(For Fluke products)
68 Havelock Rd.
Colombo, 5, Sri Lanka
Tel: (94) (1) 502202/3
Fax: (94) 1-502203
TLX: (954) 22455 COLINK CE

Sweden

Philips Kistaindustrier AB
PO Box 33
16493 Kista
Tel: 08-7031000
Fax: 08-752 0831
TLX: 17173 philkis

Svenska A.B. Philips*

Div. Industrielektronik
Avd. Matinstrument
11584 Stockholm
Tel: 782-1800

Switzerland

Philips AG Test und Messtechnik
Postfach 670
8027 Zurich
Tel: 01 4882390
Fax: 01 4828595
TLX: 815780-0

Philips SA

Test et Mesure
Avenue du Mont Blanc
1196 Gland
Tel: 022/647171

Syria

Philips Moyen-Orient S.A.R.L.
Rue Fardoss 79
PO Box 2442
Damascus
Tel: 218605/221650
TLX: phisyr 411203 sy

Taiwan

Philips Taiwan Ltd.
(For Philips products)
150, Tun Hua North Road
PO Box 22978
Taipei
Tel: 886-2-7120500
Fax: 886-2-7125442
TLX: 21570 philipei

Schmidt Electronics Corp.

(For Fluke products)
5th Floor, Cathay Min Sheng
Commercial Building,
344 Min Sheng East Road
Taipei, Taiwan R.O.C.
Tel: (886) (2) 501-3468
Fax: (886) 2-502-9692
TLX: (785) 11111 SCHMIDT

Tanzania

Philips (Tanzania) Ltd.
T.D.F.L. Building - 1st Floor
PO Box 20104
Ohio/Upanga Rd.
Dar es Salaam
Tel: 29571/4
TLX: 41016

Sales and Service all over the world

Thailand

Philips Electrical Co. of Thailand Ltd.
(For Philips products)
283, Silom Road
PO Box 961
Bangkok 10500
Tel: 66-2-233-6330/9
TLX: 87327 phltha th

Measuretronix Ltd.

(For Fluke products)
210231 Ramkamhaeng Road
Bangkok 10240
Thailand
Tel: (66) (2) 375-2733
Fax: (66) 2-374-9965
TLX: (788) 82796 HUAMARK TH

Tunisia

S.T.I.E.T.
32 bis rue Ben Ghedahem
Tunis
Tel: 348666
TLX: 14512

Turkey

Türk Philips Ticaret A.S.
Talatpasa Caddesi no. 5
PO Box 161
80640 Levent-Istanbul
Tel: 90-1-1792770
Fax: 90-1-1693094
TLX: 24192 phttr tr

United Arab Emirates

Al Sanani Trading Est.
PO Box 7187
Abu Dhabi, U.A.E.
Tel: 971-2-771370
Fax: 971-2-728963
TLX: 23966 Sanani em

Haris Al-Afaq Ltd.

PO Box 8141
Dubai, U.A.E.
Tel: 971-4-283625
TLX: 48168 Afaq em

Uruguay

Cossin Uruguay S.A.
(For Fluke products)
PO Box 1400
Libertad 2529
Montevideo, Uruguay
Tel: (598) (2) 789015
TLX: (398) 23010 COAUR UY

Venezuela

Inds. Venezolanas Phillips S.A.
(For Philips products)
Av. Francisco de Miranda
Urb. La Carlota,
Edf. Centro Empresarial Parque
del Este
Apartado 1167
Caracas 1010-A
Tel: 58-2-203, 71111
Fax: 58-2-2391090
TLX: 25267 ivpsa vc

Cossin C.A.

(For Fluke products)
Calle 9 Con Calle 4, Edifl Edinurbi
Apartado de Correos NR-70.136
Los Ruices
Caracas 1070-A, Venezuela
Tel: (58) (2) 241-03-09
TLX: (395) 21027EMVEN VC

Yemen Arab Republic

Rashed Trading & Travel Agency
Ali Abdulmugni st.
PO Box 1221
Sana'a, Yemen Arab Republic
Tel: 967-2-273231
TLX: 2230 abgbar ye

Zaire

Philips Electronics S.A.R.L.
137 Boulevard du 30 Juin
BP 16636
Kinshasa
Tel: 31693
TLX: 21078 kinshasa

Zambia

Philips Electrical Zambia Ltd.
Mwenbeshi Road
PO Box 31878
Lusaka
Tel: 218511/218701
TLX: za 41220

Zimbabwe

Philips Electrical (Pvt.) Ltd.
62 Mutare Road
PO Box 994
Harare
Tel: 47211/48031
Fax: 263-4-47966
TLX: 2236

For Countries not listed above:

Philips Export B.V.

**I & E Export
Test & Measurement**
building HVW-3
PO Box 218
5600 MD Eindhoven
The Netherlands
Tel: +31 40 711546
Fax: +31 40 711508
TLX 35000 phtc nl

Fluke Int'l Corp.

PO Box 9090
Mail Stop 206A
Everett, WA 98206-9090
Tel: 206-356-5500
Fax: (206) 356-5116
TLX: 185103 FLUKE UT

U.S.A.

Alabama

Huntsville
4920 Corporate Drive Suite J
Huntsville, AL 35805-6202
(205) 837-0581

Arizona

Phoenix
2211 S. 48th Street Suite B
Tempe, AZ 85282
(602) 438-8314

California

Irvine*
PO Box 19676
Irvine, CA 92713-9676
16969 Von Karman Ave.
Suite 100
Irvine, CA 92714
(714) 863-9031

Northern*

46610 Landing Parkway
Fremont, CA 94538
(415) 651-5112

Colorado

Denver*
14180 E. Evans Ave.
Aurora, CO 80014
(303) 695-1000

Connecticut

Hartford
Glen Lochen East
41-C New London Turnpike
Glastonbury, CT 06033
(203) 659-3541

Florida

Altamonte Springs*
550 South Northlake Blvd.
Altamonte Springs,
FL 32803
(407) 331-4881

Georgia

Atlanta
2700 Delk Road Suite 150
Marietta, GA 30067
(404) 953-4747

Illinois

Chicago*
1150 W. Euclid Avenue
Palatine, IL 60067
(708) 705-0500

Indiana

Indianapolis
8777 Purdue Road Suite 101
Indianapolis, IN 46268
(317) 875-7870

Massachusetts

Boston
Middlesex Technology Center
900 Middlesex Turnpike
Building 8
Billerica, MA 01821
(508) 663-2400

Maryland

Rockville*
5640 Fishers Lane
Rockville, MD 20852
(301) 770-1570

Michigan

Detroit
45550 Helm Street
Plymouth, MI 48170
(313) 522-9140

Minnesota

Minneapolis
1380 Corporate Center Curve
Suite 113
Eagan, MN 55121
(612) 854-5526

Missouri

St. Louis
11756 Borman Drive Suite 160
St. Louis, MO 63146
(314) 993-3805

New Jersey

Paramus*
PO Box 930
Paramus, NJ 07653-0930
West 75 Century Road
Paramus, NJ 07652
(201) 262-9550

New York

Rochester
4515 Culver Road
Rochester, NY 14622
(716) 323-1400

North Carolina

Greensboro
1310 Beaman Place
Greensboro, NC 27408
(919) 273-1918

Ohio

Cleveland
Plaza South Three Suite 402
7271 Engle Road
Middleburg Heights, OH 44130
(216) 234-4540

Pennsylvania

Philadelphia
200 Lindenwood Drive
Malvern, PA 19355
(215) 647-9550

Texas

Dallas*
1801 Royal Lane Suite 307
Dallas, TX 75229
(214) 869-0311

San Antonio

10417 Gulfdale
San Antonio, TX 78216
(512) 340-0498

Washington

Seattle*
2375 130th Ave. N.E.
Suite 100
Bellevue, WA 98005
(206) 881-6966