

# Part No. M830520

## Wi-Fi Dual Band or Tri-Band Embedded Ceramic Antenna

2.4 / 5 / 6 GHz (802.11 a/b/g/n/c + Japan)

Supports: Wi-Fi applications, Wi-Fi 6E/7, Bluetooth, Zigbee, WLAN



### Wi-Fi Dual Band or Tri-Band Embedded Ceramic Antenna

2.4 / 5 GHz or 2.4 / 5 / 6 GHz

#### KEY BENEFITS

##### Reduced Costs and Time-to-Market

Standard antenna eliminates design fees and cycle time associated with a custom solution; getting products to market faster.

##### Greater Flexibility with Unique Form Factors

KYOCERA AVX's technology helps you deliver more advanced ergonomic designs without adverse impact on product performance.

##### Environmental Compliance

Comply with latest RoHS requirements

#### APPLICATIONS

- Embedded design
- Cellular, Headsets, Tablets
- Gateway, Access Point
- Handheld
- Telematics Tracking
- Healthcare (FDA Class I)
- IoT, Industrial devices
- Smart Grid

KYOCERA AVX series of Ceramic Isolated Magnetic Dipole™ (IMD) antennas deliver on the key needs of device designers for higher functionality and

performance in smaller/thinner designs. These innovative antennas provide compelling advantages for a full WIFI dual band enabled handheld devices, media players and other mobile devices.

#### Real-World Performance and Implementation

Ceramic antennas may look alike on the outside, but the important difference is inside. Other antennas may contain simple PIFA or monopole designs that interact with their surroundings, complicating layout or changing performance with use position. KYOCERA AVX antennas utilize patented IMD technology to deliver a unique size and performance combination.

#### Greater Flexibility

KYOCERA AVX first-in-class IMD technology enables you to develop designs that are more advanced and that deliver superior performance in reception critical applications.

#### Electrical Specifications

Typical Characteristics on 40 x 80 mm PCB

Frequency (MHz)	2400 – 2485	5150 – 5825	5925 – 7125
Peak Gain	1.0 dBi	2.6 dBi	
Average Efficiency	62%	56%	
VSWR Match	2.1:1 max	2.8:1 max	
Feed Point Impedance	50 ohms unbalanced		
Polarization	Linear		
Power Handling	0.5 Watt CW		
Additional Resources	<a href="#">Download Application Note and Simulation Files</a>		

*Refer to Appendix 1*

#### Mechanical Specifications & Ordering Part Number

Ordering Part Number	M830520
Size (mm)	8.0 x 3.0 x 1.3
Mounting	SMT
Weight (grams)	0.2
Packaging	Tape & Reel, M830520 – 1,000 pieces per reel
Demo Board	M830520-01 (Wi-Fi Dual Band) M830520-02 (Wi-Fi Tri Band)
Additional Resources	<a href="#">Download DXF, Gerber and 3D FIT Files</a>

2.4 / 5 GHz KYOCERA AVX Embedded Antenna Specifications  
 KYOCERA AVX produces a wide variety of standard and custom antennas to meet user needs.

**Antenna Dimensions**

Typical antenna dimensions (mm)

Part Number	A (mm)	B (mm)	C (mm)
M830520	8.0 ± 0.2	3.0 ± 0.2	1.3 ± 0.1

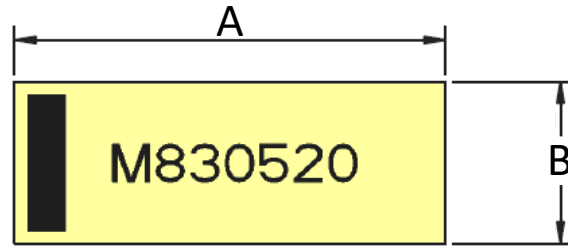
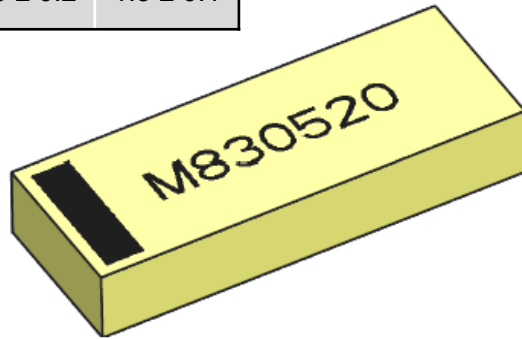

**Top View**

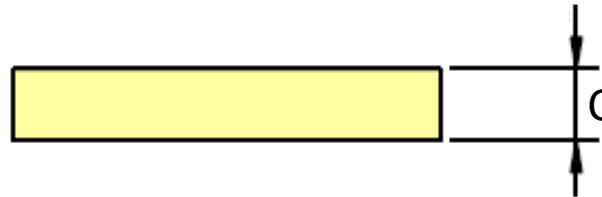

**Height**

Pin	Description
1	Feed
2	Ground
3	Dummy Pad
4	Dummy Pad
5	Dummy Pad
6	Dummy Pad

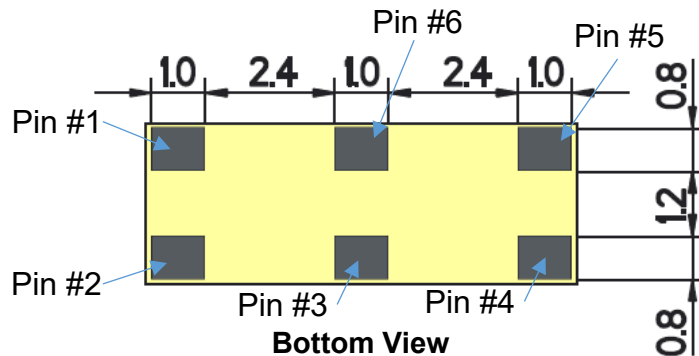

**Bottom View**

**2.4 / 5 GHz KYOCERA AVX Embedded Antenna Specifications**  
 KYOCERA AVX produces a wide variety of standard and custom antennas to meet user needs.

**VSWR and Efficiency Plots (Off-Ground)**

Typical performance on 40 x 80 mm PCB

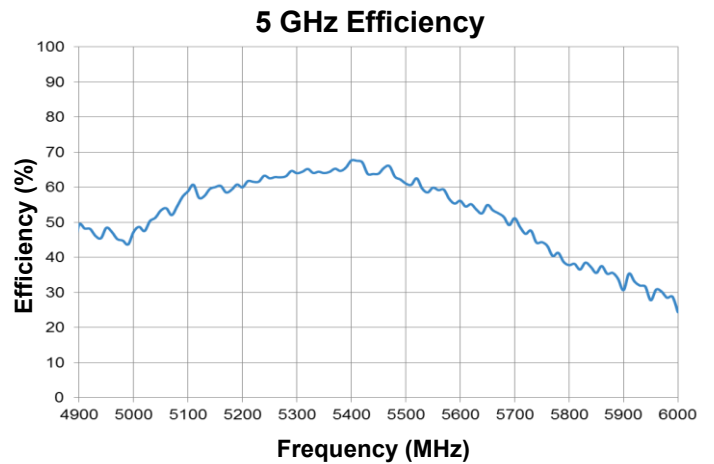
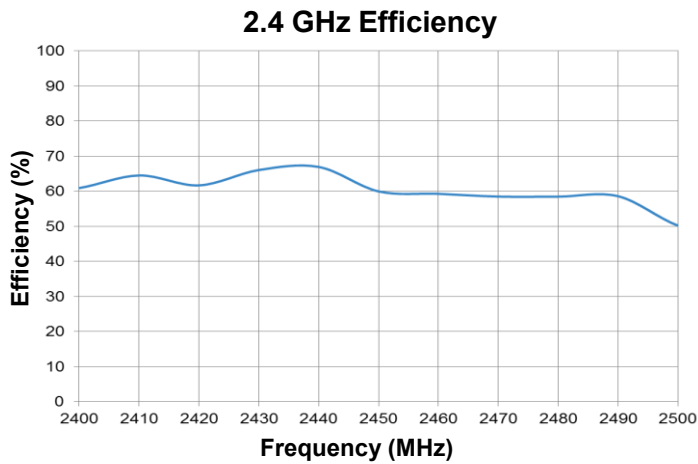
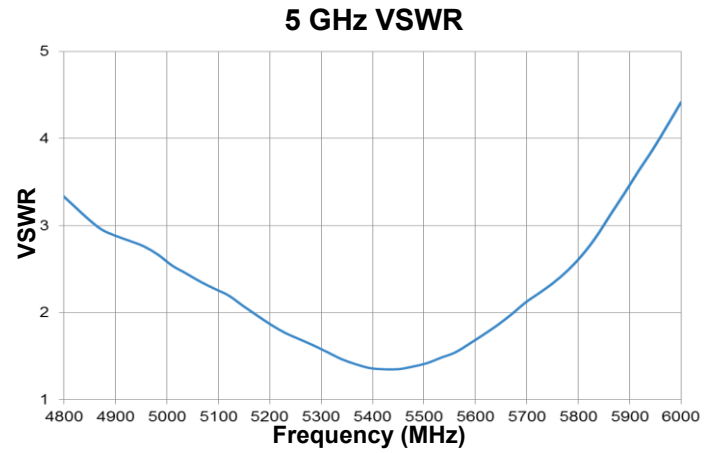
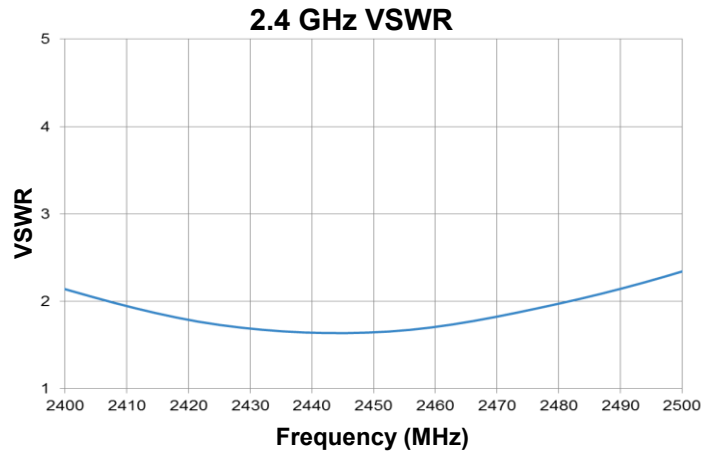

2.4 / 5 GHz KYOCERA AVX Embedded Antenna Specifications  
 KYOCERA AVX produces a wide variety of standard and custom antennas to meet user needs.

Antenna Radiation Patterns

Typical performance on 40 x 80 mm PCB

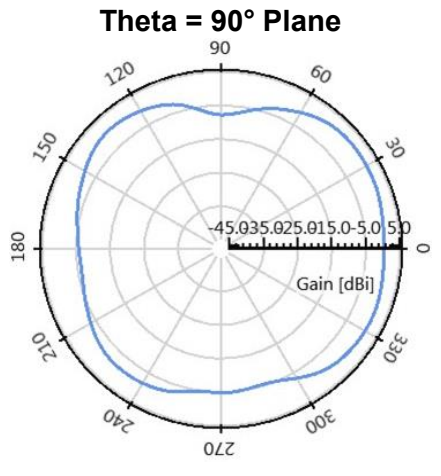
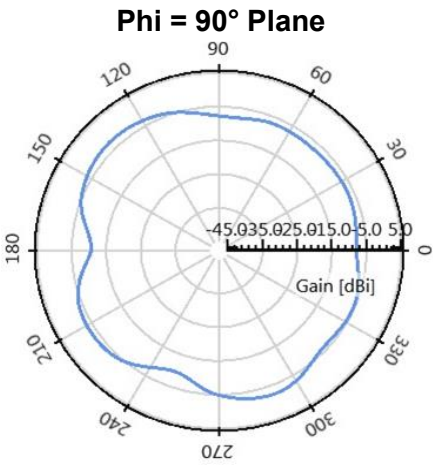
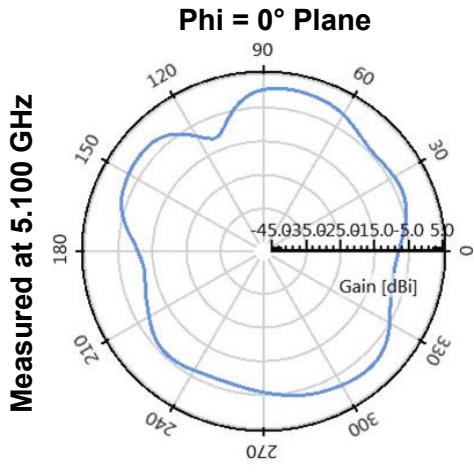
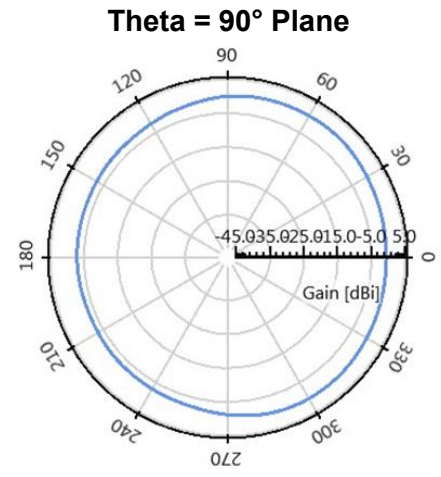
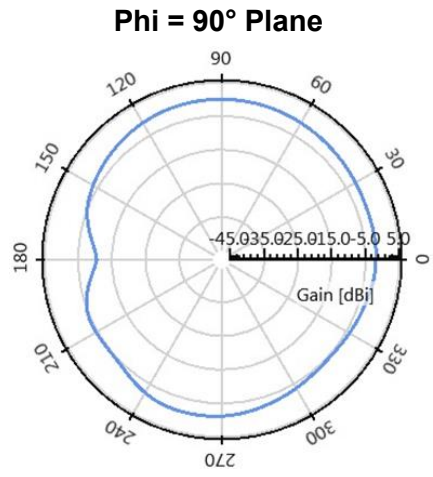
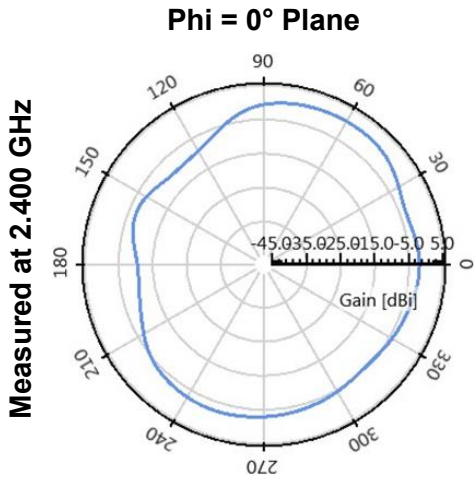
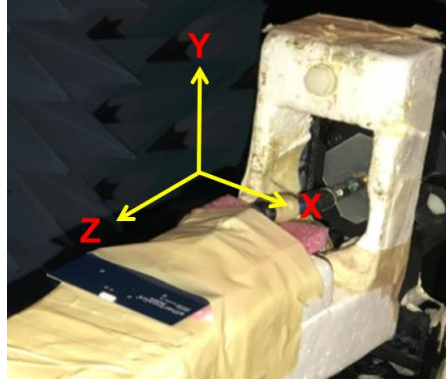

**2.4 / 5 GHz KYOCERA AVX Embedded Antenna Specifications**  
 KYOCERA AVX produces a wide variety of standard and custom antennas to meet user needs.

**Antenna Layout (Off-Ground)**

Typical layout dimensions (mm)

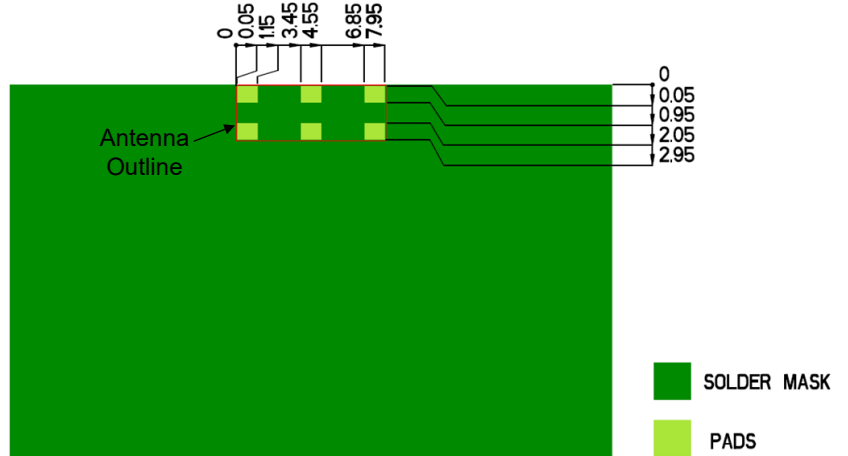
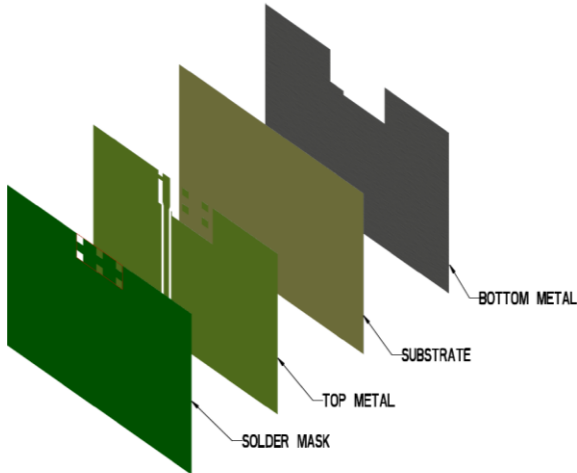

- Additional VIAS: Diam. 0.2mm to be placed around antenna, (no vias on transmission lines).
- Via holes must be covered by solder mask

**Pin Descriptions**

Pin#	Description
1	Feed
2	Ground
3	Dummy Pad
4	Dummy Pad
5	Dummy Pad
6	Dummy Pad

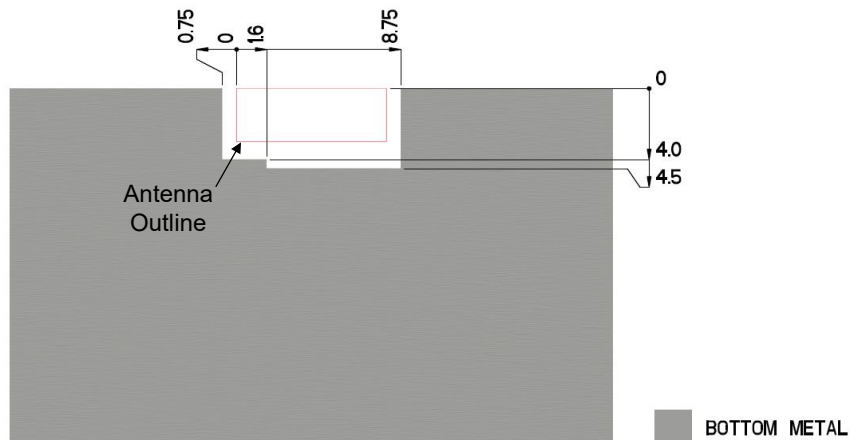
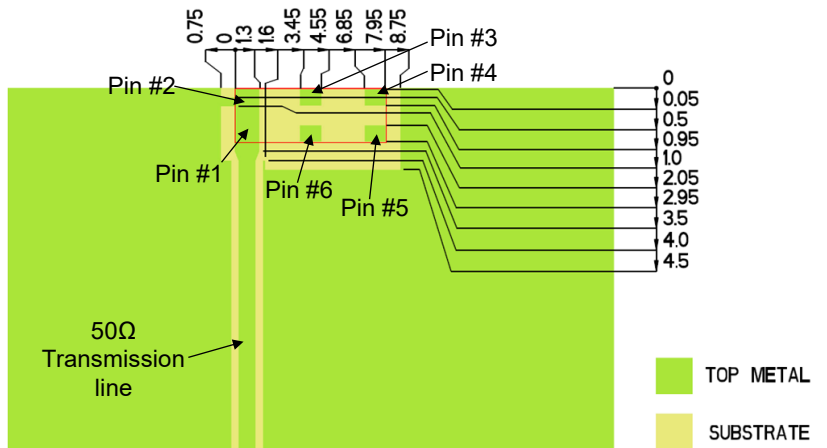

2.4 / 5 GHz KYOCERA AVX Embedded Antenna Specifications  
 KYOCERA AVX produces a wide variety of standard and custom antennas to meet user needs.

**Antenna Demo Board**

Typical layout dimensions (mm)

Part Number	A (mm)	B (mm)	C (mm)
M830520-01	80.0	40.0	36.0

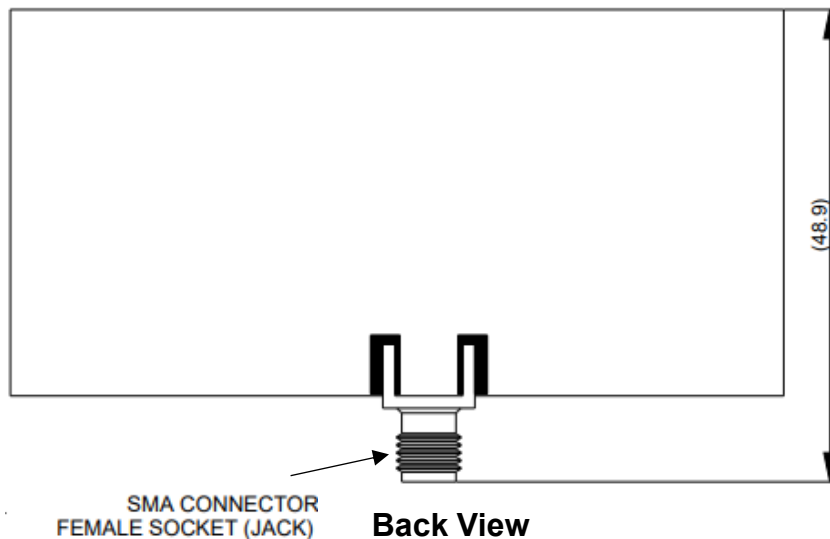
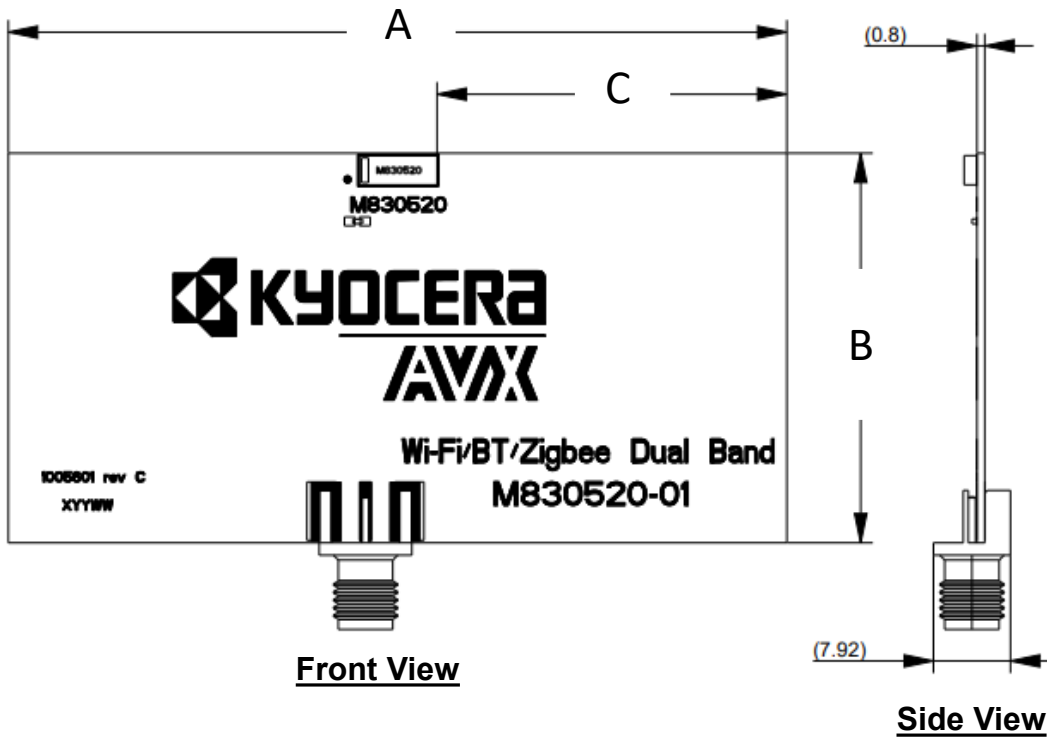

2.4 / 5 / 6 GHz KYOCERA AVX Embedded Antenna Specifications.  
KYOCERA AVX produces a wide variety of standard and custom antennas to meet user needs.

# Appendix 1

Appendix 1 gives instructions on how to achieve  
Tri-Band Wi-Fi 6E/7 to cover till 7.125 GHz  
through layout modifications.

(2.4-2.48 GHz)  
(5.150-5.825GHz)  
**(5.925-7.125 GHz)**

Frequency (MHz)	2400 - 2485	5150 - 5825	5925-7125
Peak Gain	2.6 dBi	2.5 dBi	4.0 dBi
Average Efficiency	58%	61%	63%
VSWR Match	< 3:1	< 3:1	< 3:1
Polarization	Linear		
Power Handling	0.5 Watt CW		
Feed Point Impedance	50 Ω unbalanced		

*\*Data shown above over 20 x 65 mm PCB.*

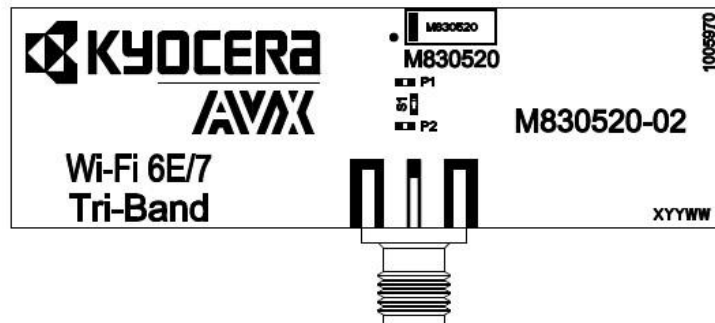

2.4 / 5 / 6 GHz KYOCERA AVX Embedded Antenna Specifications  
 KYOCERA AVX produces a wide variety of standard and custom antennas to meet user needs.

**Return Loss, Efficiency and Peak Gain Plots**

Typical performance on 20 x 65 mm PCB

**Return Loss (2400 – 2500 MHz)**

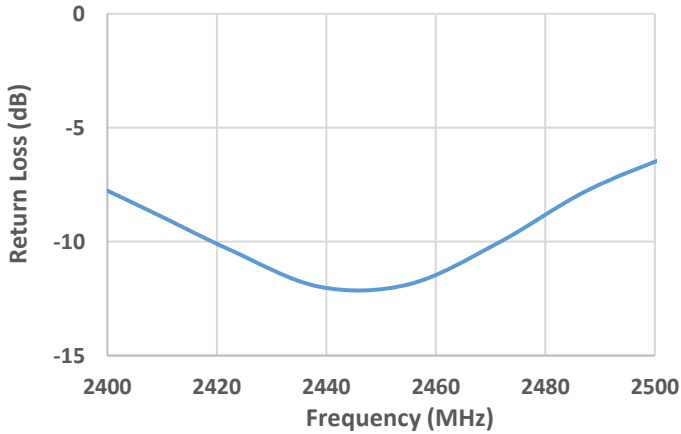

**Return Loss (5150 – 5850 MHz)**

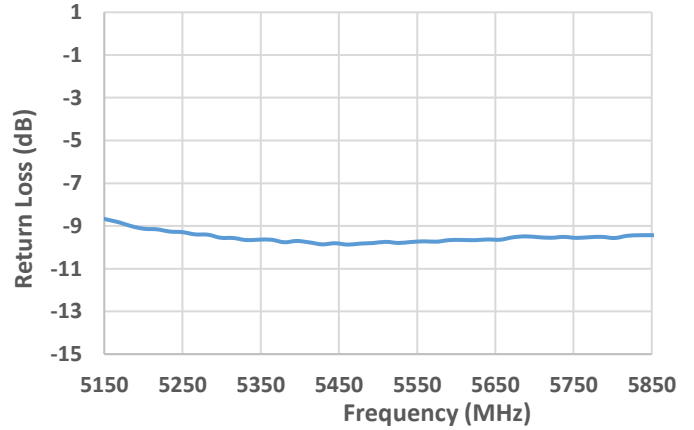

**Efficiency (2400 – 2500 MHz)**

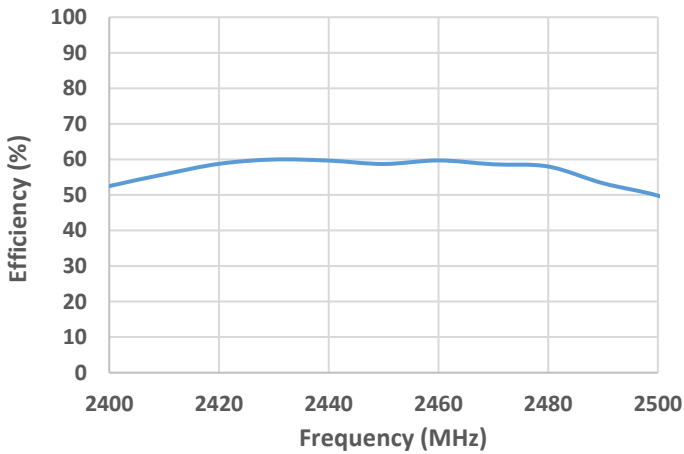

**Efficiency (5150 – 5850 MHz)**

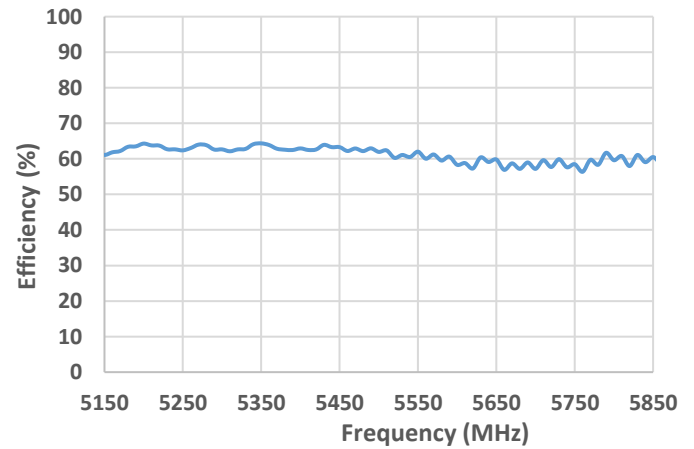

**Peak Gain (2400 – 2500 MHz)**

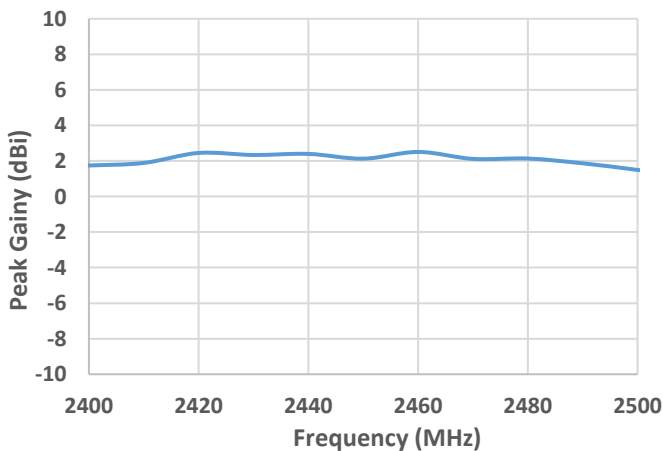

**Peak Gain (5150 – 5850 MHz)**

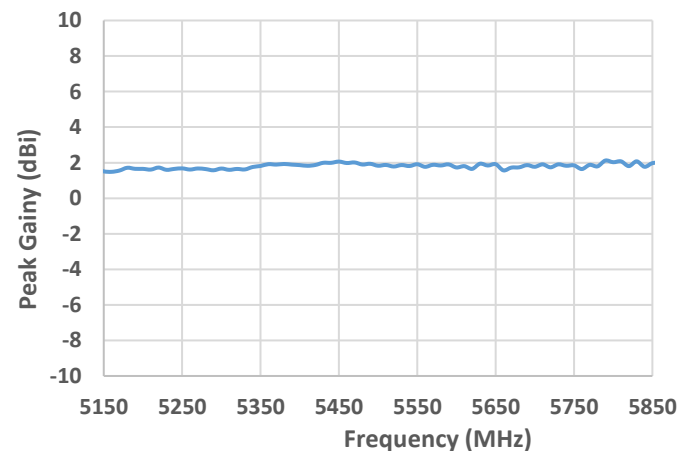

2.4 / 5 / 6 GHz KYOCERA AVX Embedded Antenna Specifications  
 KYOCERA AVX produces a wide variety of standard and custom antennas to meet user needs.

**Return Loss, Efficiency and Peak Gain Plots**

Typical performance on 20 x 65 mm PCB

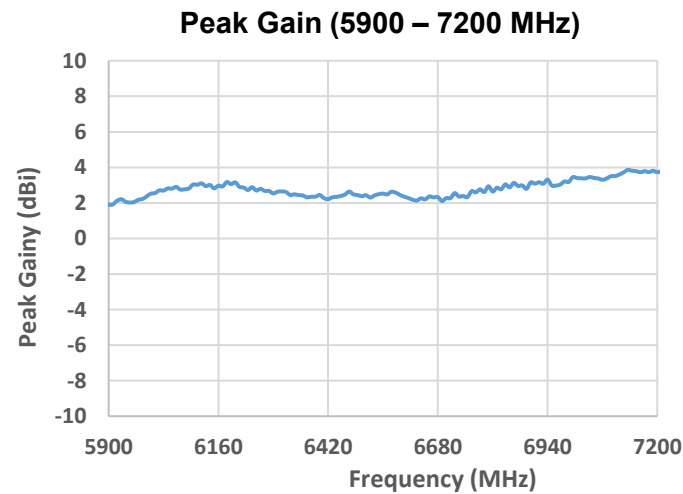
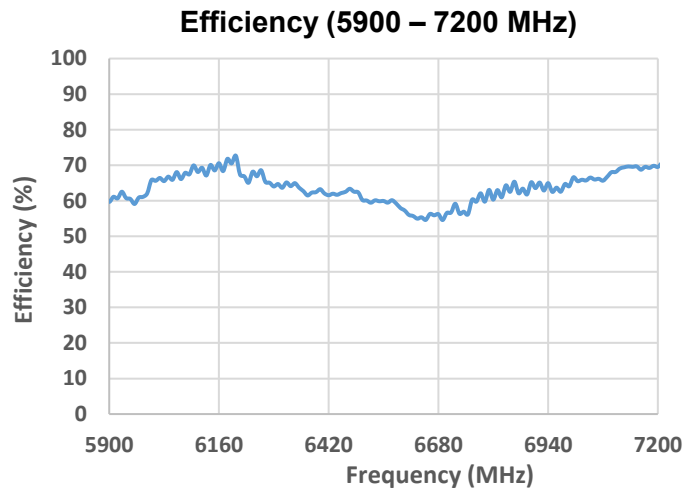
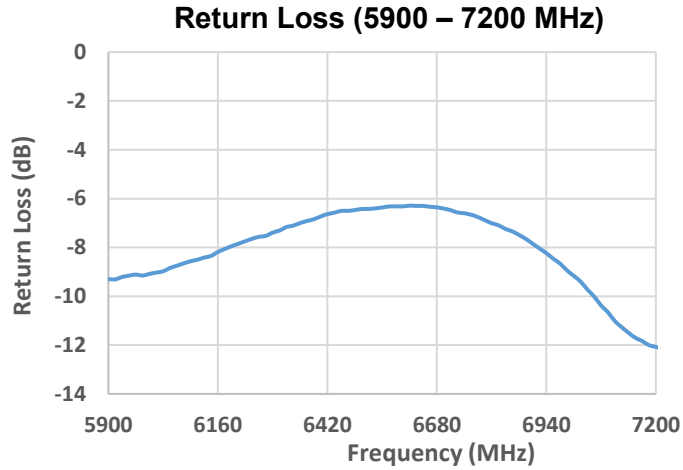

**2.4 / 5 / 6 GHz KYOCERA AVX Embedded Antenna Specifications**  
 KYOCERA AVX produces a wide variety of standard and custom antennas to meet user needs.

**Antenna Radiation Patterns**

Typical performance on 20 x 65 mm PCB  
 Measured at 2440 MHz

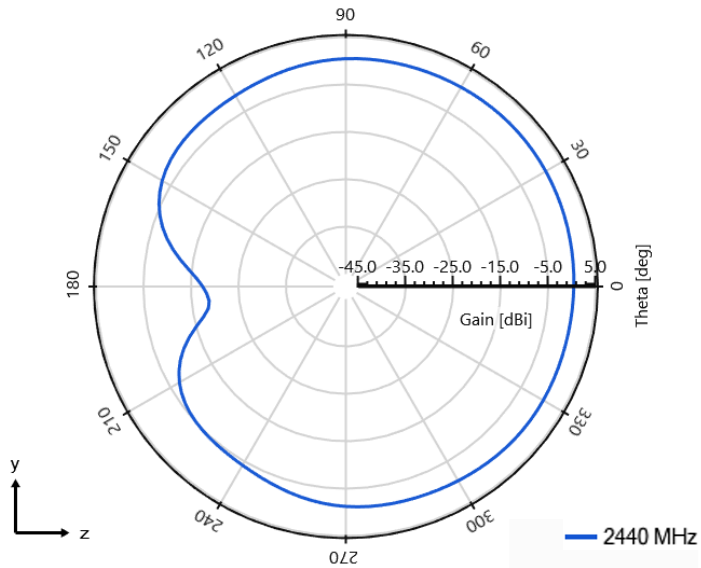
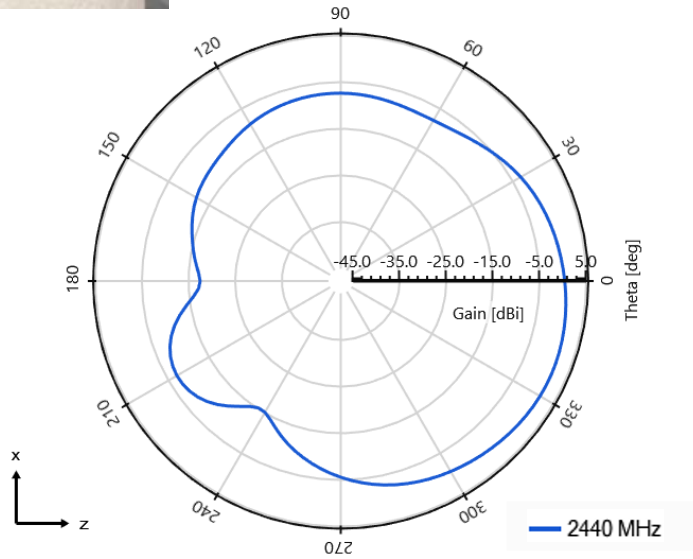
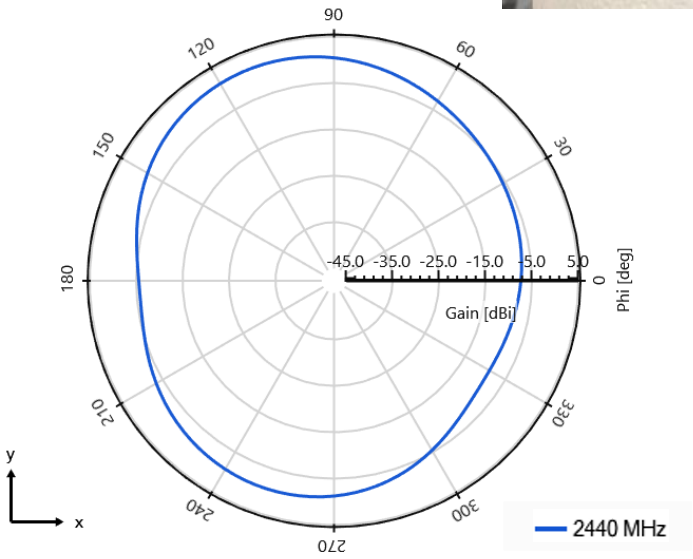
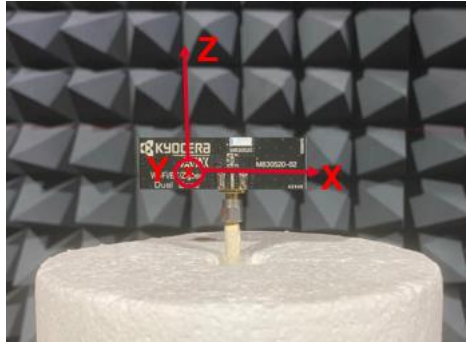

**2.4 / 5 / 6 GHz KYOCERA AVX Embedded Antenna Specifications**  
 KYOCERA AVX produces a wide variety of standard and custom antennas to meet user needs.

**Antenna Radiation Patterns**

Typical performance on 20 x 65 mm PCB  
 Measured at 5600 MHz

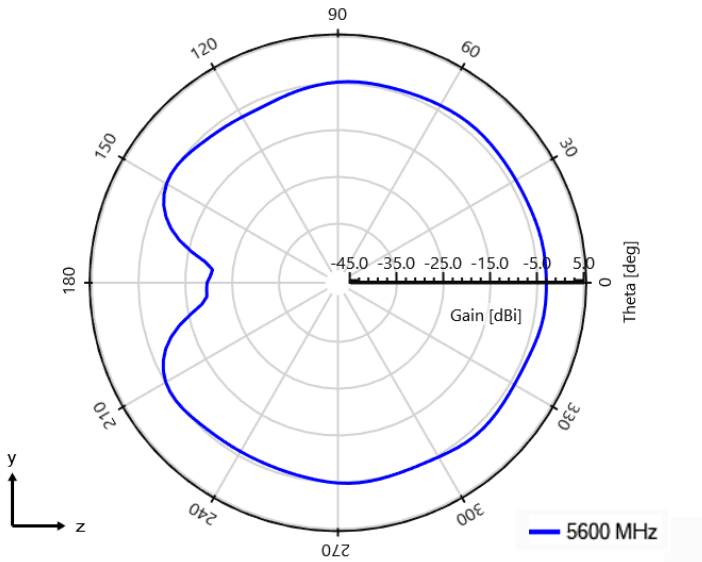
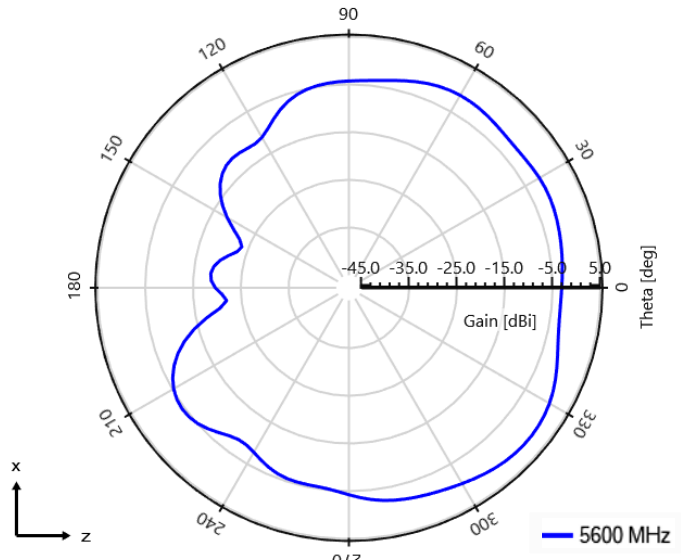
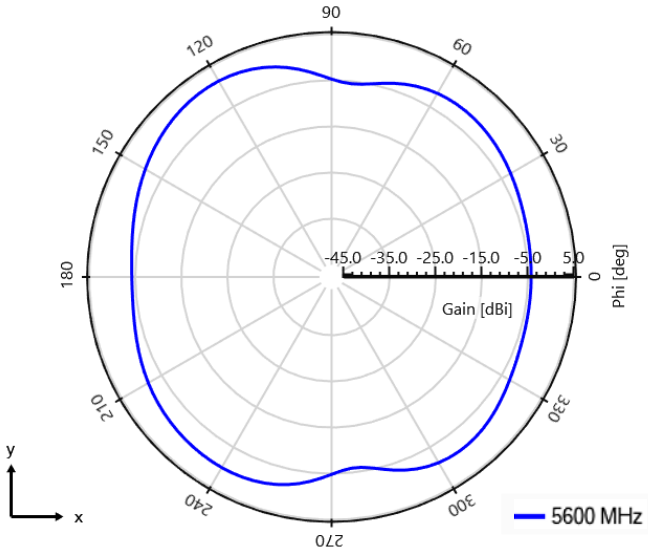
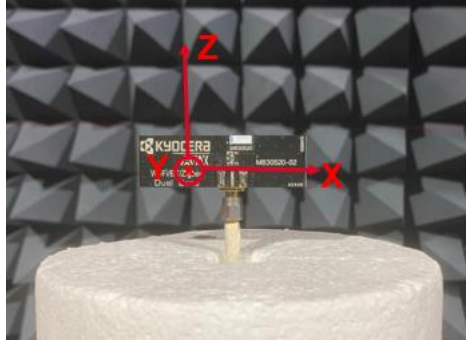

**2.4 / 5 / 6 GHz KYOCERA AVX Embedded Antenna Specifications**  
 KYOCERA AVX produces a wide variety of standard and custom antennas to meet user needs.

**Antenna Radiation Patterns**

Typical performance on 20 x 65 mm PCB  
 Measured at 6450 MHz

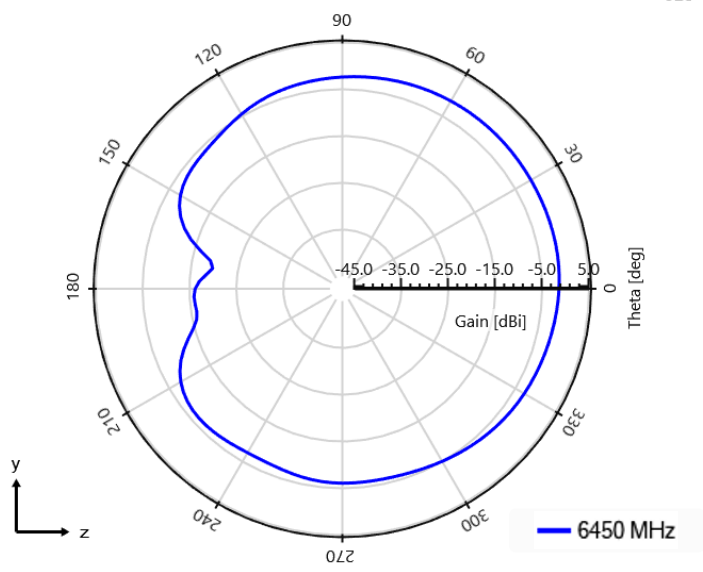
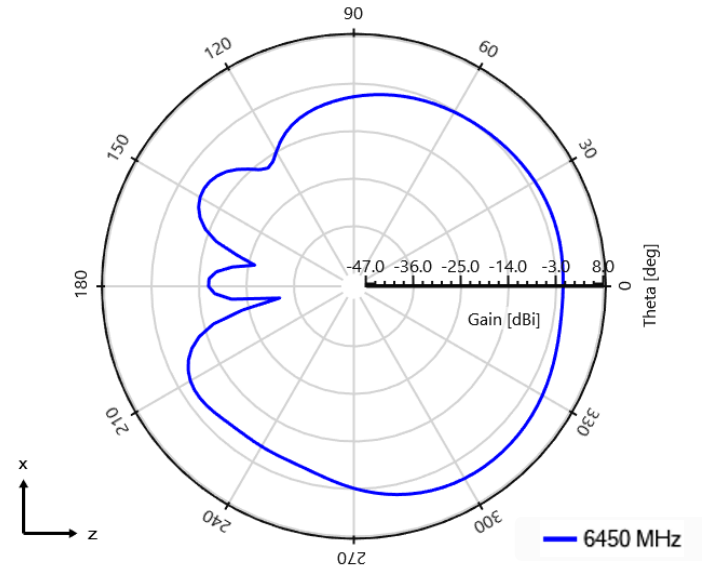
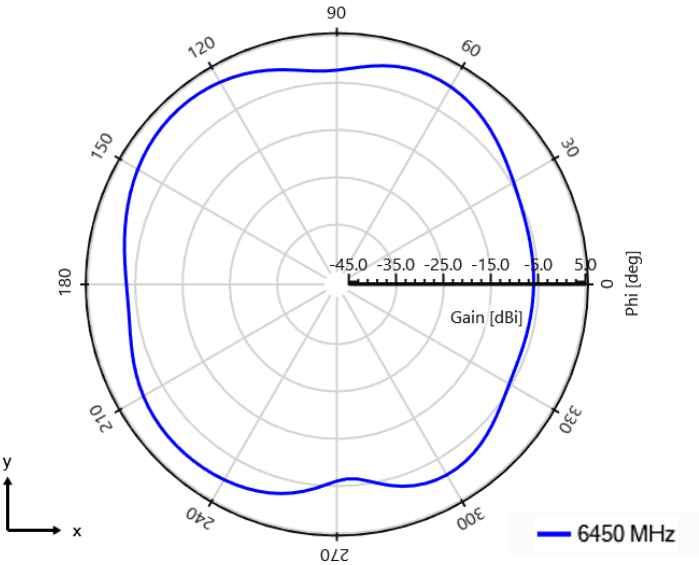
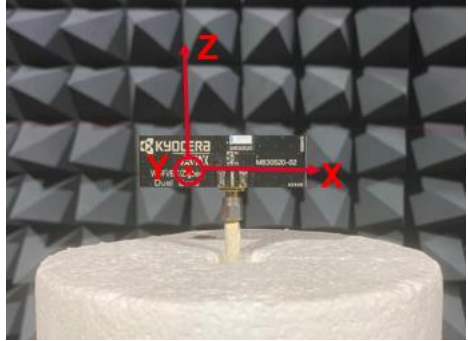

**2.4 / 5 / 6 GHz KYOCERA AVX Embedded Antenna Specifications**  
 KYOCERA AVX produces a wide variety of standard and custom antennas to meet user needs.

**Antenna Layout (M830520-02)**

Typical layout dimensions (mm)

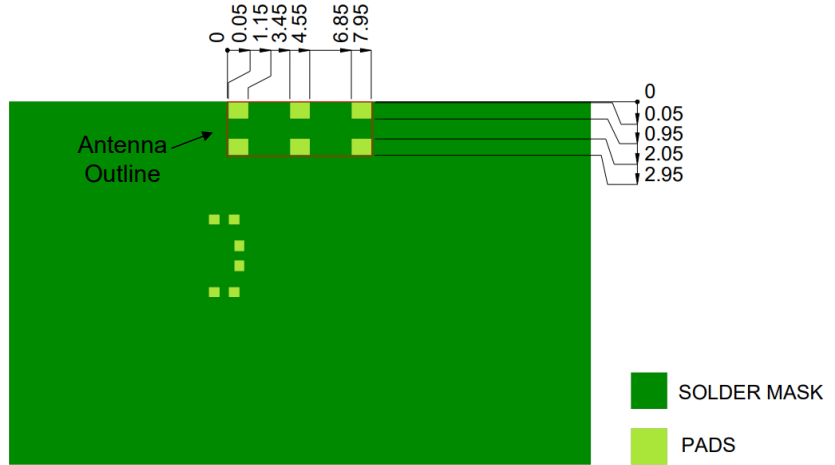
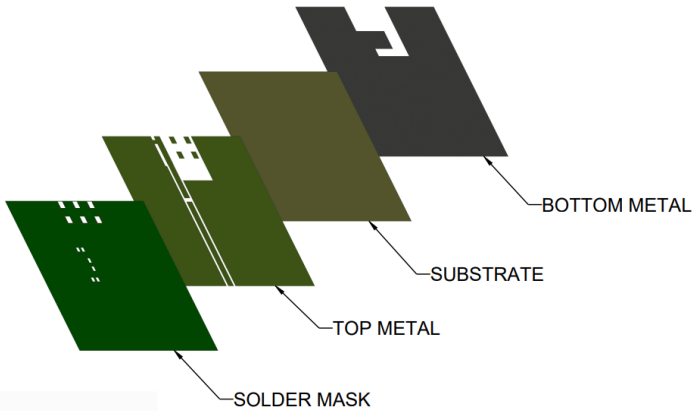

- Additional VIAS: Diam. 0.2mm to be placed around antenna, (no vias on transmission lines).
- Via holes must be covered by solder mask

**Pin Descriptions**

Pin#	Description
1	Feed
2	Ground
3	Dummy Pad
4	Dummy Pad
5	Dummy Pad
6	Dummy Pad

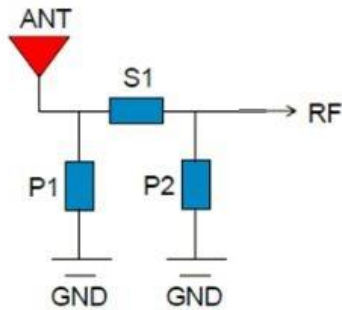
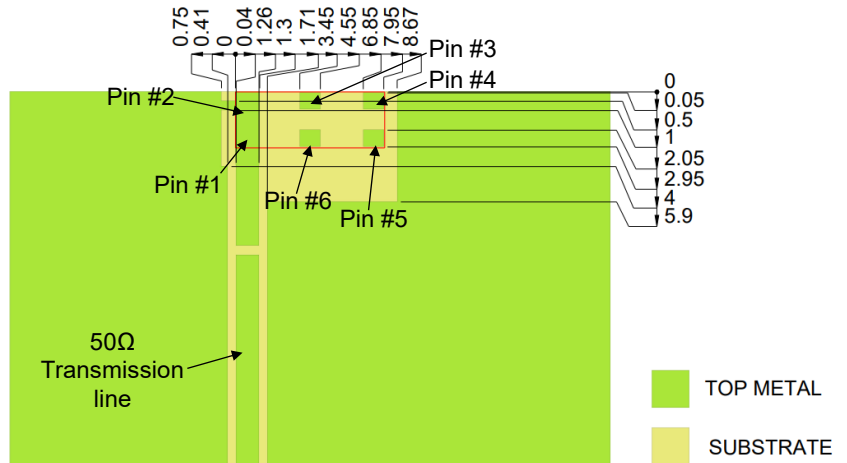

**Matching Pi Network (Demo Board)**

Component	Value
P1	N/A
S1	0 ohm
P2	N/A

\*Actual matching values depend on customer design

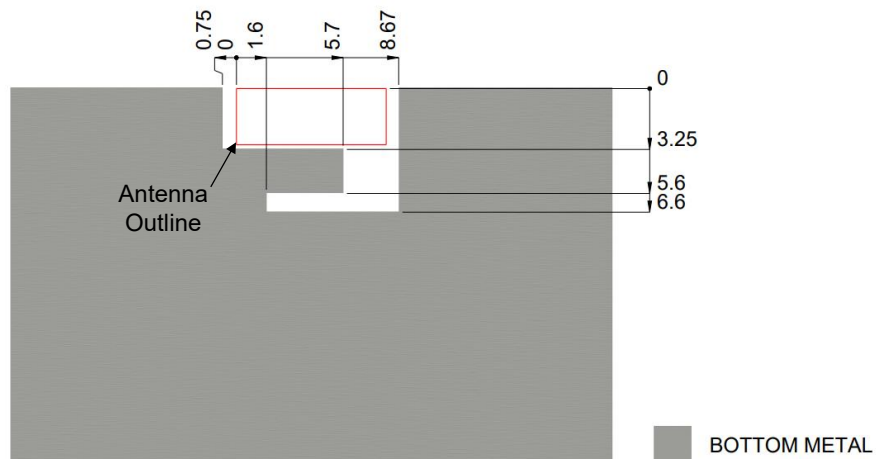

**2.4 / 5 / 6 GHz KYOCERA AVX Embedded Antenna Specifications**  
 KYOCERA AVX produces a wide variety of standard and custom antennas to meet user needs.

**Antenna Demo Board**

Typical layout dimensions (mm)

Part Number	A (mm)	B (mm)	C (mm)
M830520-02	65.0	20.0	20.9

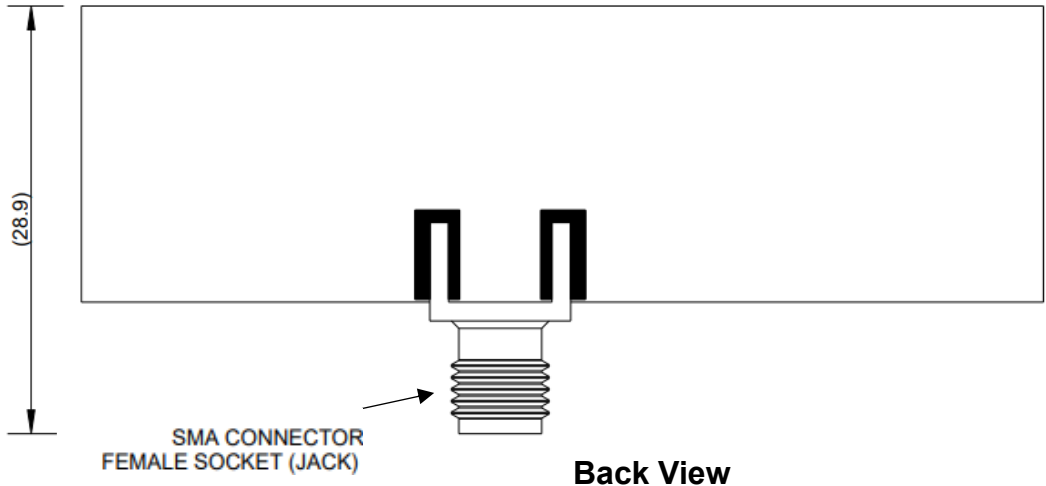
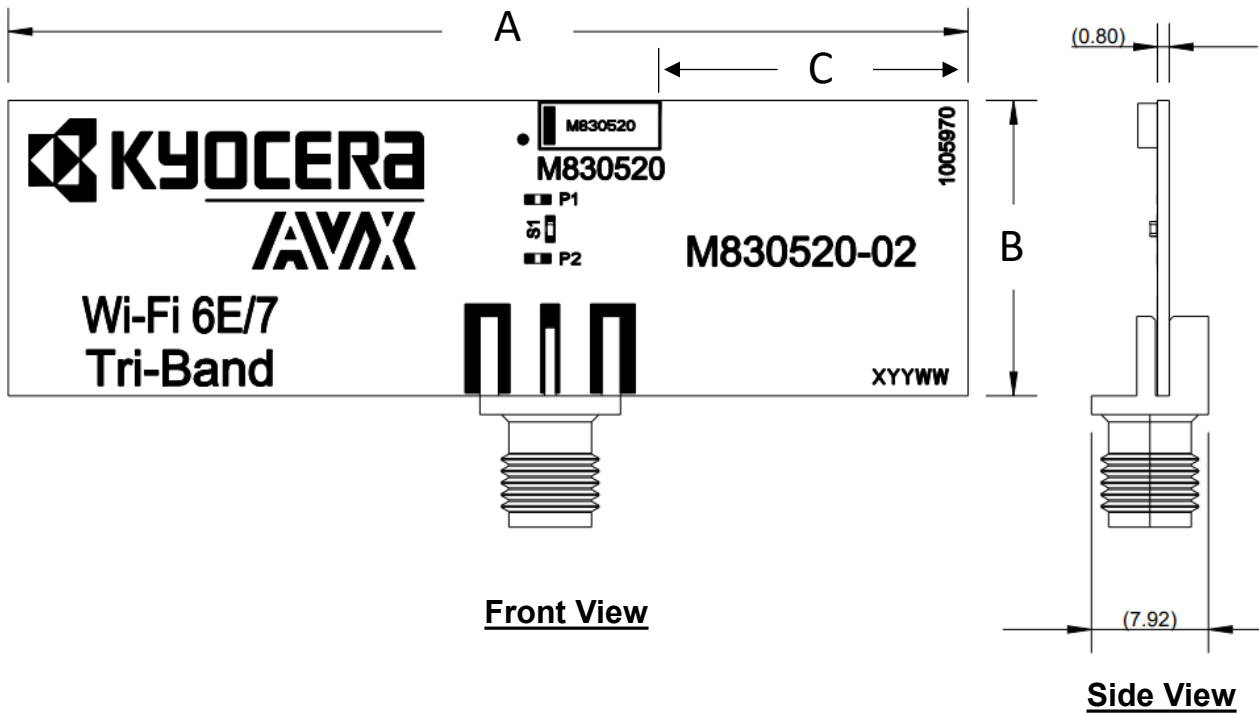

2.4 / 5 GHz KYOCERA AVX Embedded Antenna Specifications  
KYOCERA AVX produces a wide variety of standard and custom antennas to meet user needs.

---

### Additional Resources – M830520

**Simulation Files:**

HFSS (23 R1): [https://www.kyocera-avx.com/download/antennas/ansys-hfss/23r1/M830520\\_08232022\\_23r1.zip](https://www.kyocera-avx.com/download/antennas/ansys-hfss/23r1/M830520_08232022_23r1.zip)

HFSS (19R3-22R2): [https://www.kyocera-avx.com/download/antennas/ansys-hfss/19r3/M830520\\_08232022\\_19r3.zip](https://www.kyocera-avx.com/download/antennas/ansys-hfss/19r3/M830520_08232022_19r3.zip)

CST : [https://www.kyocera-avx.com/download/antennas/CST/M830520\\_CST\\_071024\\_23r1.zip](https://www.kyocera-avx.com/download/antennas/CST/M830520_CST_071024_23r1.zip)

**Application Note:**

[https://www.kyocera-avx.com/docs/techinfo/ApplicationNotes/Antenna-AppNotes/AVX-E\\_AppNote-M-Series.pdf](https://www.kyocera-avx.com/docs/techinfo/ApplicationNotes/Antenna-AppNotes/AVX-E_AppNote-M-Series.pdf)

**3D FIT File:**

[https://www.kyocera-avx.com/download/antennas/ME-FIT/M830520\\_ME\\_fit.zip](https://www.kyocera-avx.com/download/antennas/ME-FIT/M830520_ME_fit.zip)

**DXF File:**

[https://www.kyocera-avx.com/download/antennas/3D-DXF/M830520\\_3D-DXF.zip](https://www.kyocera-avx.com/download/antennas/3D-DXF/M830520_3D-DXF.zip)

**Gerber File:**

[https://www.kyocera-avx.com/download/antennas/GERBER/M830520\\_GERBERS.zip](https://www.kyocera-avx.com/download/antennas/GERBER/M830520_GERBERS.zip)