

Power Dissipation at 10A, 175°C Tjunc is 10W for P-Channel and 3W for N-Channel fets

Special care must be taken when DIR changes. PWM _must_ be 0 for enough time to let the gates rise

width of wires should be 5mm or more

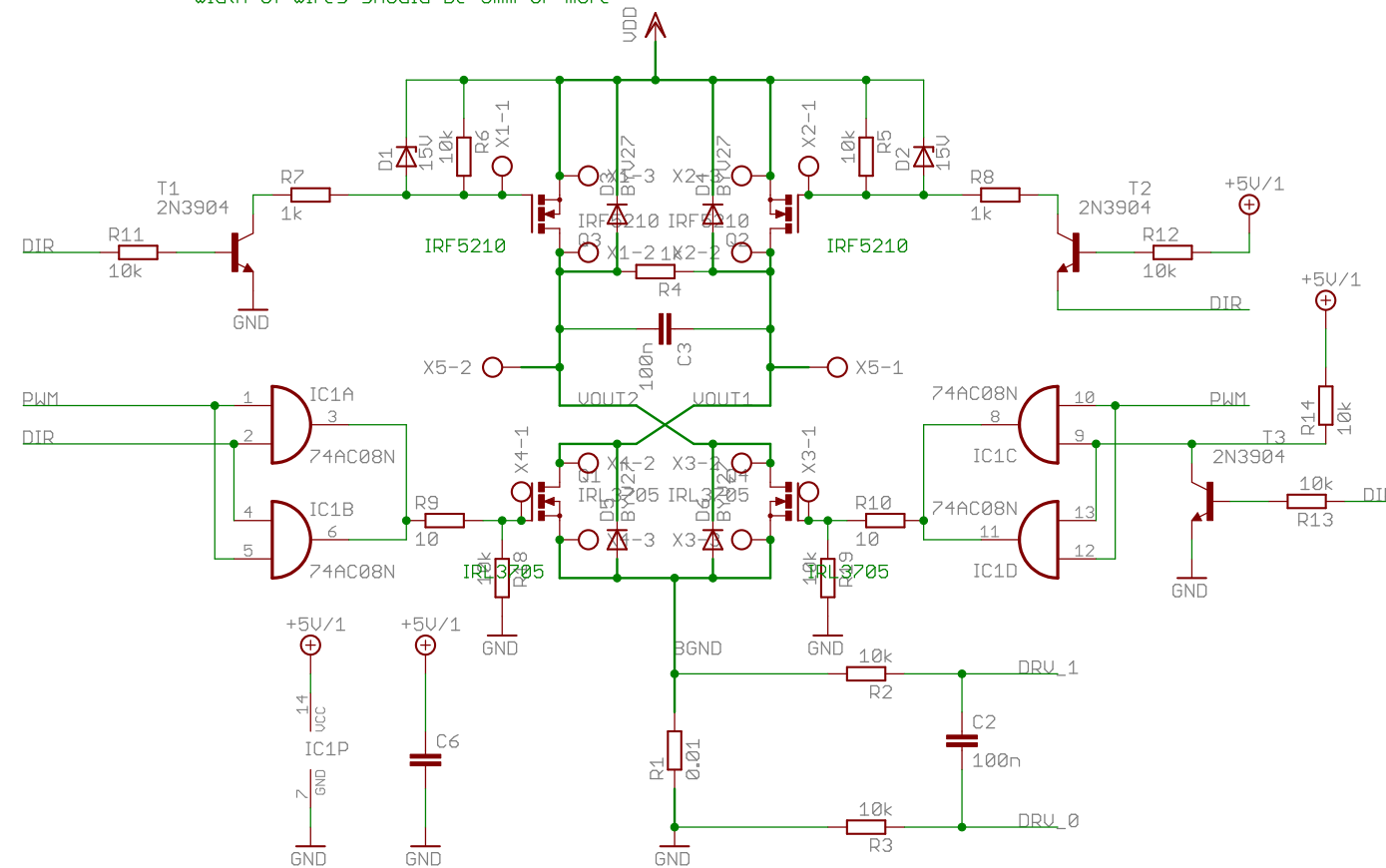
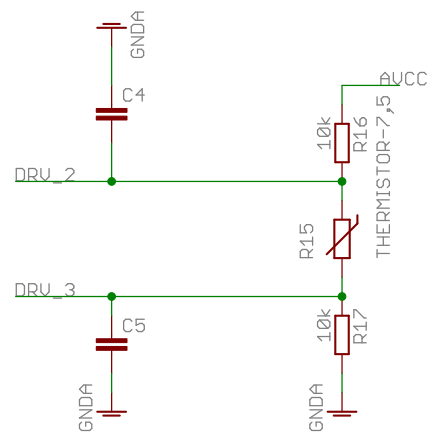

Driver Connection

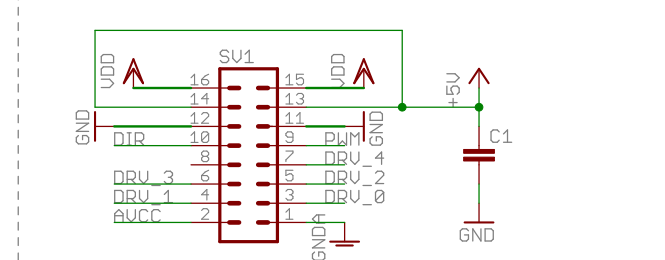

TITLE: driver_fet2	
Document Number:	REV:
Date: 21 Apr 2010 23:08:51	Sheet: 1/1